



PRESENTED BY:



PLAYGROUND CONSULTANCY



LANDSCAPE ARCHITECTURE



PLAYGROUND

STUDY REPORT 2022:

- + Assessment
- + Maintenance
- + Planning

Prepared for: Salem Public Schools



2022 Playground Study Report

Prepared for the City of Salem Public Schools, in Massachusetts

PAGE INTENTIONALLY

LEFT BLANK

2022 Playground Study Report

Prepared for the City of Salem Public Schools, in Massachusetts

ACKNOWLEDGEMENTS

Mary C. DeLai, Assistant Superintendent, Finance & Employee Engagement, Salem Public Schools

Zissis Alepakis, Director of Facilities, Salem Public Schools

Daniel Byors, Daily Operations Manager, Salem Public Schools

School Community

PINE and M3 Land Studio appreciate the opportunity to assist Salem Public Schools in this 2022 Playground Study Report. In particular, we would like to thank Mary DeLai for spearheading this important project, assisting with the online surveys, and the development of this report. Thanks also go to Zissis Alepakis and Daniel Byors for their assistance with the onsite playground visits.

Furthermore, we would also like to acknowledge the crucial role of the school community that participated on the online survey, providing their feedback and insight on how they use their playgrounds, and what are their wishes for the new/renovated playgrounds.

Prepared by:
Nancy White of Playground
Inspections of New England +
Mariana Mariscal of M3 Land Studio



LANDSCAPE ARCHITECTURE



Playground Inspections
of New England LLC

PLAYGROUND CONSULTANCY

TABLE OF CONTENTS

DEFINITIONS..... 1

PHASE 1: PLAYGROUND + SITE ASSESSMENTS..... 5

Objectives..... 6

Playground Assessment Forms 6

IMPORTANT NOTES ON THE ASSESSMENTS..... 7

SAFETY CONCERN PRIORITY RATING SYSTEM DEFINITIONS 8

BATES ELEMENTARY SCHOOL 2-5 Y.O. PLAYGROUND 9

BATES ELEMENTARY SCHOOL 5-12 Y.O. PLAYGROUND..... 16

SALEM EARLY CHILDHOOD SCHOOL 2-5 Y.O. PLAYGROUND 26

BENTLEY ACADEMY INNOVATION SCHOOL 5-12 Y.O. PLAYGROUND..... 34

SALTONSTALL SCHOOL KINDERGARTEN PLAYGROUND..... 44

SALTONSTALL SCHOOL 5-12 Y.O. PLAYGROUND..... 49

HORACE MANN LABORATORY SCHOOL 2-5 Y.O. PLAYGROUND..... 56

HORACE MANN LABORATORY SCHOOL 5-12 Y.O. PLAYGROUND 63

WITCHCRAFT HEIGHTS ELEMENTARY SCHOOL 5-12 Y.O. PLAYGROUND 69

Summary of the Playground Assessment..... 81

2022 Playground Study Report

Prepared for the City of Salem Public Schools, in Massachusetts

| | |
|--|----|
| Play Equipment Rating by Site | 83 |
| Conclusion on Playground Assessments | 83 |
| Summary of the Online Survey..... | 85 |

PHASE 2: PLAYGROUND MAINTENANCE + MANAGEMENT 103

| | |
|--|-----|
| Introduction | 104 |
| Hazards and Risks | 106 |
| Incorporating Policy of Best Practice for School Playground Maintenance..... | 107 |
| Outlining a Policy | 107 |
| Documentation + Record to Maintain | 108 |
| Forms + Checklists + Accident Report..... | 108 |
| In-Person Training..... | 114 |

PHASE 3: PLAYGROUND PLANNING 115

| | |
|--|-----|
| Objectives..... | 116 |
| GENERAL PLANNING RECOMMENDATIONS FOR <u>EXISTING</u> SCHOOL PLAYGROUND IMPROVEMENTS..... | 117 |
| Planning Recommendations for Repair, Maintenance and Management of <u>Existing</u> School Playgrounds..... | 118 |
| PLANNING RECOMMENDATIONS PER <u>EXISTING</u> SCHOOL PLAYGROUND..... | 120 |
| Planning Recommendations for <u>New</u> School Playgrounds..... | 121 |
| GENERAL DESIGN PRINCIPLES FOR <u>NEW</u> SCHOOL PLAYGROUNDS | 122 |
| CONCLUSION OF REPORT | 124 |
| PINE DISCLAIMER | 125 |
| M3 Land Studio DISCLAIMER..... | 125 |

Prepared by:
Nancy White of Playground
Inspections of New England +
Mariana Mariscal of M3 Land Studio



LANDSCAPE ARCHITECTURE



PLAYGROUND CONSULTANCY

2022 Playground Study Report

Prepared for the City of Salem Public Schools, in Massachusetts

REFERENCES..... 126

APPENDIX 127

- A. Online survey 128
- B. Full Size Playground Layouts/ PDFs by Manufacturers..... 129
- C. MAAB Regulations + Access Board ADA Guides for Play Areas 130

Prepared by:
Nancy White of Playground
Inspections of New England +
Mariana Mariscal of M3 Land Studio



LANDSCAPE ARCHITECTURE

PLAYGROUND CONSULTANCY

DEFINITIONS

CPSI Certified Playground Safety Inspector

Third Party CPSI a playground inspector that provides to the Client unbiased playground safety inspections, free from conflict of interests. (Third Party CPSI is not a manufacturer's sales representative, installer of play equipment or surfacing, or a playground designer, etc.)

PIP Poured-in-Place resilient rubber playground safety surface is composed of two layers: **EPDM**, Ethylene Propylene Diene Monomer (made from virgin rubber) topcoat and colored layer, and **SBR**, Styrene Butadiene Rubber (made of 100% post-consumer recycled rubber), bottom, black layer. These layers are unitarily bonded by **Aromatic** or **Aliphatic Polyurethane** binders. Sometimes, **TPV** Thermo Plastic Vulcanized rubber granules (also made from made from virgin rubber, but from a single source) can be used instead of the EPDM ones.

EWF Engineered Wood Fiber playground safety surface.

Play Value is the degree to which a playground and its equipment offers multiple layers of opportunities to engage the users to develop social, physical, intellectual, and moral skills through play.

Free Play is unstructured, voluntary, child-initiated activity that allows children to develop their imaginations while exploring and experiencing the world around them. It is the spontaneous play that comes from children's natural curiosity, love of discovery, and enthusiasm¹.

Plumb is a measure of the upright position of a post, column, or vertical structure in a 90-degree relationship to the horizontal axis.

¹<https://www.pgpedia.com/f/free-play>

2022 Playground Study Report

Prepared for the City of Salem Public Schools, in Massachusetts

Professional Judgment/Opinion is the ability of an individual with current knowledge, skill, and experience in the field of playground, playground equipment, design, and/or operation, to form an opinion or decide using this level of expertise as a guideline.

PVC Coating Polyvinyl chloride is a soft rubbery coating on metal playground equipment, such as decks, stairs, transfer stations, etc.

PVC Paste is a PVC coating that can be used to fill in areas where the original PVC coating has worn off or has exposed the underlying metal. As well as used in areas where PVC coating cannot reach, such as arches and other vulnerable areas.

Retrofit is to modify parts or portions of play equipment that is already in service.

Spalling formal definition: break (ore, rock, stone, or concrete) into smaller pieces; to break off in fragments. "Cracks below the surface cause material to spall off". Hard material, which is starting to, or is currently shedding rust, usually in layers. I.e., a deck that its PVC coating is losing its original PVC coating from normal wear and tear. The metal shows, starts to rust, and then spalls. Rust flakes and settles on top of itself.

Use zone is the marginal area or empty space, typically set around the playground equipment for safety reasons. These use zones help spacing between play structures or components to allow users ample amount of room, so injuries are avoidable.

PLAYGROUND RELATED STANDARDS AND GUIDELINES:

CPSC Consumer Product Safety Commission Public Playground Safety Handbook (free PDF from [cpsc.gov](https://www.cpsc.gov))

ASTM American Society for Testing Materials has the goal of enhancing performance and safety over a wide range of products, materials, systems, and services (purchase from [ASTM Intl](https://www.astm.org)).

ASTM F355-16E01 Standard Test Method for Impact Attenuation of Playing Surface Systems, Other Protective Sport Systems, and Materials Used for Athletics, Recreation and Play

2022 Playground Study Report

Prepared for the City of Salem Public Schools, in Massachusetts

ASTM F1292 Standard Specification for Impact Attenuation of Surfacing Materials within the Use Zone of Playground Equipment

ASTM F1487 Standard Consumer Safety Performance Specification for Playground Equipment for Public Use

ASTM F1637 Standard Practice for Safe Walking Surfaces: provides minimum maintenance requirements for safe walkways, including exterior walkways and sidewalks. It states:

- *Exterior walkways shall be maintained so as to provide safe walking conditions.*
- *Exterior walkway conditions that may be considered substandard and in need of repair include conditions in which the pavement is broken, depressed, raised, undermined, slippery, uneven, or cracked to the extent that pieces may be readily removed.*
- *Exterior walkways shall be repaired or replaced where there is an abrupt variation in elevation between surfaces.*

ASTM F1918 Standard Safety Performance Specification for Soft Contained Play Equipment

ASTM F1951 Standard Specification for Determination of Accessibility of Surface Systems Under and Around Playground Equipment

ASTM F2049 Standard Safety Performance Specification for Fences/Barriers for Public, Commercial, and Multi-Family Residential Use Outdoor Play Areas

ASTM F2075 Standard Specification for Engineered Wood Fiber for Use as a Playground Safety Surface Under and Around Playground Equipment

ASTM F2223 Standard Guide for ASTM Standards on Playground Surfacing

ASTM F2373 Playground Equipment for Children Under the Age of Two

ASTM F2479 Standard Guide for Specification, Purchase, Installation and Maintenance of Poured-In-Place Playground Surfacing

Department of Justice ADA [Guidelines](#) and [Standards](#)

2022 Playground Study Report

Prepared for the City of Salem Public Schools, in Massachusetts

PLAYGROUND RELATED RESOURCES:

The Daily Dozen: A 12-Point Playground Safety [Checklist](#)

ASTM [International](#)

Consumer Product Safety Commission ([CPSC](#))

International Playground Equipment Manufacturers Association ([IPEMA](#))

National Playground Contractors Association ([NPCA](#))

International Playground Safety Institute ([IPSI](#))

[US Play Coalition](#)

Canadian Standards Association ([CSA Group](#))

OTHER ADA RELATED RESOURCES:

US Access Board Guide to the ADA Accessible Standards [Chapter 10: Play Areas](#)

Massachusetts Architectural Access Board ([MAAB](#)):

521 CMR 19.00: RECREATIONAL FACILITIES

521 CMR 20.00: ACCESSIBLE ROUTE

521 CMR 21.00: CURB CUTS

521 CMR 22.00: WALKWAYS

521 CMR 24.00: RAMPS

Accessible Routes in Play Areas- [MOD Blog](#)

PHASE 1:

PLAYGROUND +

SITE ASSESSMENTS



"When children come into contact with nature, they reveal their strength" - Maria Montessori

Outdoor play has proven to be an essential part of a child's learning and development. In the last years of shutdowns due to the global pandemic, playgrounds and outdoor recreation spaces have proven to be one of the few open locations to provide much needed human interactions. Even within a restrictive physical distance of "six feet apart", playgrounds and play spaces are now regarded as valuable places, since they have proven to improve our physical and mental health in times of health risks and uncertainties.

2022 Playground Study Report

Prepared for the City of Salem Public Schools, in Massachusetts

OBJECTIVES

This report has the following goals for the school Playgrounds within the seven public schools in the City of Salem:

1. To provide an onsite **Playground and Site Assessment** (Phase I) to understand the current conditions of the play equipment and the space adjacent to it. An evaluation and prioritization, minimum to optimum recommendation, will be given at the end of this section.
2. To provide general **Playground Maintenance and Management** processes based on ASTM and CPSC Safety Standards to ensure its safe operation and longevity. Employ protocols will be by playground Owner.
3. Overall **Playground and Site Planning Recommendation** based on realistic goals, and Standards of Care.

PLAYGROUND ASSESSMENT FORMS

The following forms consider a total of nine playgrounds in the following City of Salem Public Schools:

1. Bates Elementary School - two Playgrounds: 2 to 5 and 5 to 12-year-old Playgrounds
2. Salem Early Childhood School: 2 to 5-year-old Playground
3. Bentley Academy Innovation School: 5 to 12-year-old Playground
4. Saltonstall School - two Playgrounds: Kindergarten and 5 to 12-year-old Playgrounds
5. Horace Mann Laboratory School - two Playgrounds: 2 to 5 and 5 to 12-year-old Playgrounds
6. Witchcraft Heights Elementary School: 5 to 12-year-old Playground

2022 Playground Study Report

Prepared for the City of Salem Public Schools, in Massachusetts

IMPORTANT NOTES ON THE ASSESSMENTS

1. Although **Carlton Innovation School** has a space for play, it lacks stationary play equipment and therefore was not assessed for this report. In addition, we learned from the online school survey that Carlton students use the Curtis Park public playground. This playground was also excluded from the assessment study given that the Owner is the City of Salem, not our client, Salem Public Schools.
2. All available "**2D Layouts**" presented below, were supplied by the play equipment manufacturers, and are presented "as is". Please note that in some cases these drawings do not reflect the current/existing play equipment layout. Also note that these drawings are missing for most playgrounds due to one or more of the following reasons:
 - a. Poor response from manufacturer involved. (Change in Sales Rep, with no transfer of files or files not available from their archive, as playground is too old/outdated).
 - b. Obsolete components and no communication with manufacturer to provide needed updates.
 - c. No relationship or partnership with manufacturer after sale to abreast of most current safety guidelines or regulations for new updates.
 - d. Change in manufacturer/design ownership make them not available.

Therefore, the available 2D Layouts included are mostly from recent installations. The lack of these drawings as assistant tools means that potential retrofits will be limited for the current equipment needs (repair, replace or update a part of the equipment).
3. Where colored pavement or **basketball courts** were observed adjacent to the playground, they were considered as "part of the playground" and as such, some basic recommendations were made.
4. The playground assessments below do not include the Massachusetts Architectural Access Board (**MAAB**) regulation compliance, as it would be repetitive. This note summarizes the MAAB regulations and assessments. The MAAB develops and enforces regulations to make public playgrounds in Massachusetts universally accessible. Under 521 CMR Section 19.7: "An accessible route, complying with 521 CMR 20... shall be

2022 Playground Study Report

Prepared for the City of Salem Public Schools, in Massachusetts

provided to reach playground equipment and around the playground". Over the years, the MAAB has expanded its role and taken on multiple responsibilities, focusing on playground safety surfacing in public playgrounds. They have defined universally accessible certain products such as PIP (as seen in Bates 2-5 YO, Salem Early Childhood Center, and Bentley schools' playgrounds). Products like Rubber Tiles, Playground Turf, and Grass Mats are also ADA compliant in MAAB regulations, but NOT EWF safety surfacing. This has led to more stringent ADA playground regulations than those currently enforced by the US Department of Justice (DOJ). Therefore, the following playgrounds with EWF are not compliant with current MAAB regulations:

- a. Bates Elementary School 5-12 YO playground*
- b. Saltonstall School (although both playgrounds have Grass mats, poor paving)*
- c. Horace Mann Laboratory School (both playgrounds)*
- d. Witchcraft Heights Elementary School playground*

It is important to note that it is usually through a filed complaint to MAAB that a playground Owner realizes of this non-compliance. When anyone, at any given time files a complaint, the MAAB board investigates and alerts the owner of the complaint. A letter is sent to the Owner with information and any final implication of a fine. If the Owner has a working plan, the Owner can seek a variance and submit the new playground plan to rectify. Please refer to above ADA links for further review.

SAFETY CONCERN PRIORITY RATING SYSTEM DEFINITIONS

POOR: HAZARD 1: *Non-Compliant safety concern that may result in permanent disability, loss of life or body part. **Condition should be corrected immediately.***

FAIR: HAZARD 2: *Non-Compliant safety concern that may result in a serious injury resulting in temporary disability. **Condition should be corrected as soon as possible.***

GOOD: HAZARD 3: *Non-Compliant safety concern that is likely to cause a minor (non-disabling) injury. **Condition should be corrected when time allows; do not postpone indefinitely.***

COMPLIANT: *Assessed as compliant; continue with regular maintenance.*

2022 Playground Study Report

Prepared for the City of Salem Public Schools, in Massachusetts

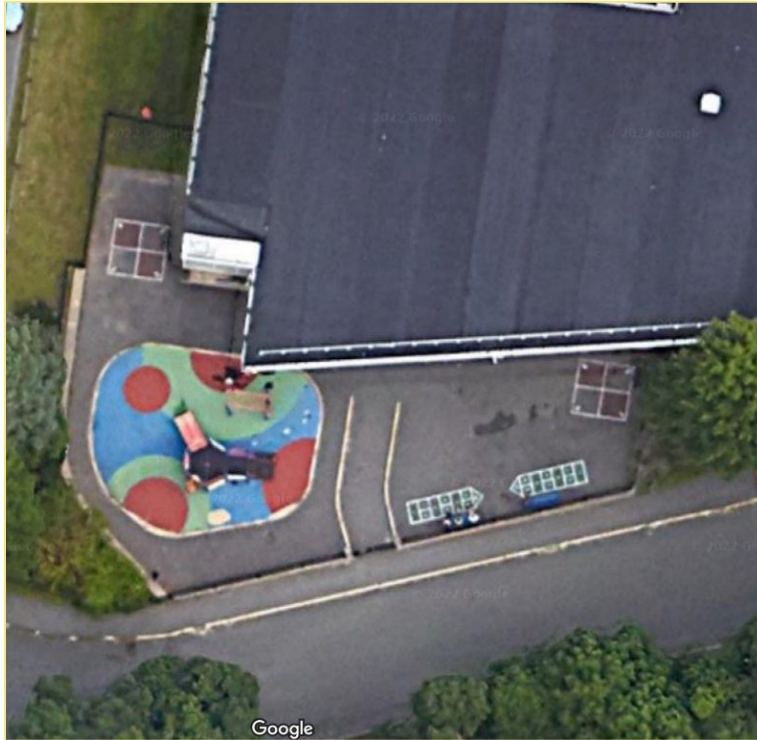

PLAYGROUND NAME:

BATES ELEMENTARY
SCHOOL 2-5 Y.O.
PLAYGROUND

PLAYGROUND ADDRESS:

**53 Liberty Hill Ave. Salem,
MA 01970**

DATE OF SITE VISIT:

03 May 2022

MANUFACTURER/S:

Park Structures

AGE APPROPRIATE:

| | | | |
|---|-----------------------------------|-----------------------------------|----------------------------------|
| <input checked="" type="checkbox"/> 2-5 YRS | <input type="checkbox"/> 5-12 YRS | <input type="checkbox"/> 2-12 YRS | <input type="checkbox"/> 13+ YRS |
|---|-----------------------------------|-----------------------------------|----------------------------------|

1. GENERAL SITE CONDITIONS AND APPROACH:

| | | | |
|-------------------------------|-------------------------------|--|------------------------------------|
| <input type="checkbox"/> POOR | <input type="checkbox"/> FAIR | <input checked="" type="checkbox"/> GOOD | <input type="checkbox"/> COMPLIANT |
|-------------------------------|-------------------------------|--|------------------------------------|

- *Playground is adequately enclosed, and fence is in good condition. Gates needs child safety lock/s.*
- *Access is good through a sloped asphalt walkway edged by concrete curbs on either side. This sloped entry walkway is awkwardly placed, as it bisects the two play areas instead of being incorporated into one area and having a better circulation/flow. It may pose a tripping hazard, given curb steps on each side, separating the two play areas. (Refer to site photos). The raised curbs on each side are greater than 6 inches in height. (Not ADA compliant for a child with a wheelchair or cane trying to move between play areas).*
- *Shade is lacking and may help, especially during the warmer months.*

2022 Playground Study Report

Prepared for the City of Salem Public Schools, in Massachusetts

2. VISUAL SURFACING REVIEW:

SURFACING TYPE(S):

| | | | | | |
|------------------------------|---|--------------------------------|-------------------------------|--------------------------------|--------------------------------------|
| <input type="checkbox"/> EWF | <input checked="" type="checkbox"/> PIP | <input type="checkbox"/> TILES | <input type="checkbox"/> SAND | <input type="checkbox"/> GRASS | <input type="checkbox"/> OTHER _____ |
|------------------------------|---|--------------------------------|-------------------------------|--------------------------------|--------------------------------------|

| | | | |
|-------------------------------|--|-------------------------------|------------------------------------|
| <input type="checkbox"/> POOR | <input checked="" type="checkbox"/> FAIR | <input type="checkbox"/> GOOD | <input type="checkbox"/> COMPLIANT |
|-------------------------------|--|-------------------------------|------------------------------------|

- *PIP Surfacing needs to meet the edge of concrete.*
- *PIP has recently been patched; however, there are areas that still need patching and are cracking.*
- *The surfacing may not pass the Head Drop Test (due to patching).*
- *The PIP is rated as fair, due to missing and incomplete edging. This will allow weeds to grow and creates tripping hazards.*

3. COMPONENT STRUCTURE REVIEW:

| | | | |
|--|-------------------------------|-------------------------------|------------------------------------|
| <input checked="" type="checkbox"/> POOR | <input type="checkbox"/> FAIR | <input type="checkbox"/> GOOD | <input type="checkbox"/> COMPLIANT |
|--|-------------------------------|-------------------------------|------------------------------------|

- *The slide bed has a stress crack.*
- *Age-appropriate structure, except for the 'corkscrew event'.*
- *The middle of structure with deck joint is open which will allow fingers to pass through.*
- *The decks are all peeling and there is a good deal of missing PVC coating. Needs immediate repair or replacement.*
- *The structure has rust setting in on painted steel welds.*
- *The transfer station needs immediate repair or replacement.*

Play Equipment Inventory:

- *(1) Double slide*
- *Play panels: (1) Number rolls, (1) Car Wheel, (2) Opening circles, (1) Window*
- *Corkscrew climber- Note: only recommended for 5-12 yr. olds*

2022 Playground Study Report

Prepared for the City of Salem Public Schools, in Massachusetts

- *Transfer station*
- *Deck platform*

4. FREE STANDING EQUIPMENT (INCLUDING SWINGS):

| | | | |
|-------------------------------|--|-------------------------------|------------------------------------|
| <input type="checkbox"/> POOR | <input checked="" type="checkbox"/> FAIR | <input type="checkbox"/> GOOD | <input type="checkbox"/> COMPLIANT |
|-------------------------------|--|-------------------------------|------------------------------------|

- *Overhead Horizontal Ladder is not age appropriate for 2-3 yr. olds ("Horizontal ladders less than or equal to 60" high are only appropriate for ages 4 and 5" yr. olds.)*
- *This overhead play structure may be too high for them to reach unassisted.*

5. SITE AMENITIES:

| | | | |
|-------------------------------|--|-------------------------------|------------------------------------|
| <input type="checkbox"/> POOR | <input checked="" type="checkbox"/> FAIR | <input type="checkbox"/> GOOD | <input type="checkbox"/> COMPLIANT |
|-------------------------------|--|-------------------------------|------------------------------------|

- *The steel benches are beginning to peel.*

6. SUMMARY | RECOMMENDATIONS

OVERALL CONDITION OF PLAYGROUND:

| | | | |
|--|-------------------------------|-------------------------------|------------------------------------|
| <input checked="" type="checkbox"/> POOR | <input type="checkbox"/> FAIR | <input type="checkbox"/> GOOD | <input type="checkbox"/> COMPLIANT |
|--|-------------------------------|-------------------------------|------------------------------------|

- *It is NOT cost effective to retrofit this structure.*
- *Remove and add new equipment; there are an overwhelming number of **hazards**.*
- *PIP will have to have a new subbase, SBR rubber cushion and EPDM top layer. Thus, the entire area will need to be rehabilitated.*
- *May consider using a 50% black and 50% color PIP, as it is less expensive.*
- *Suggest using play panels in the next design to expand the play value.*
- *The site is small, but a moving piece of equipment would be advised (if there is room).*
- *If new playground is to be designed, entry ramp may be reconsidered to provide a better/safer and ADA compliant circulation.*
- *Touch up paint at benches.*

2022 Playground Study Report

Prepared for the City of Salem Public Schools, in Massachusetts

- *Drain Manhole under middle of play equipment is ADA compliant. Our recommendation would be to at least cover it with an EPDM PIP layer to prevent preschool children from 'throwing things' in there or putting their fingers inside the grate.*

7. PLAYGROUND PHOTOGRAPHS

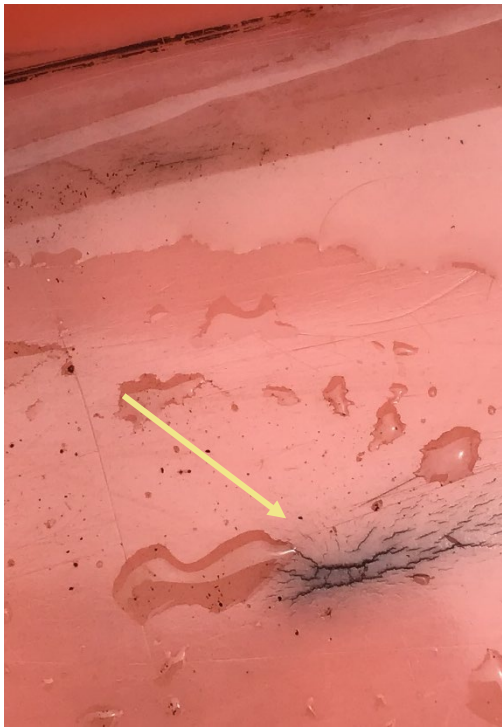

2022 Playground Study Report

Prepared for the City of Salem Public Schools, in Massachusetts



8. PLAYGROUND SITE PHOTOGRAPHS:



2022 Playground Study Report

Prepared for the City of Salem Public Schools, in Massachusetts

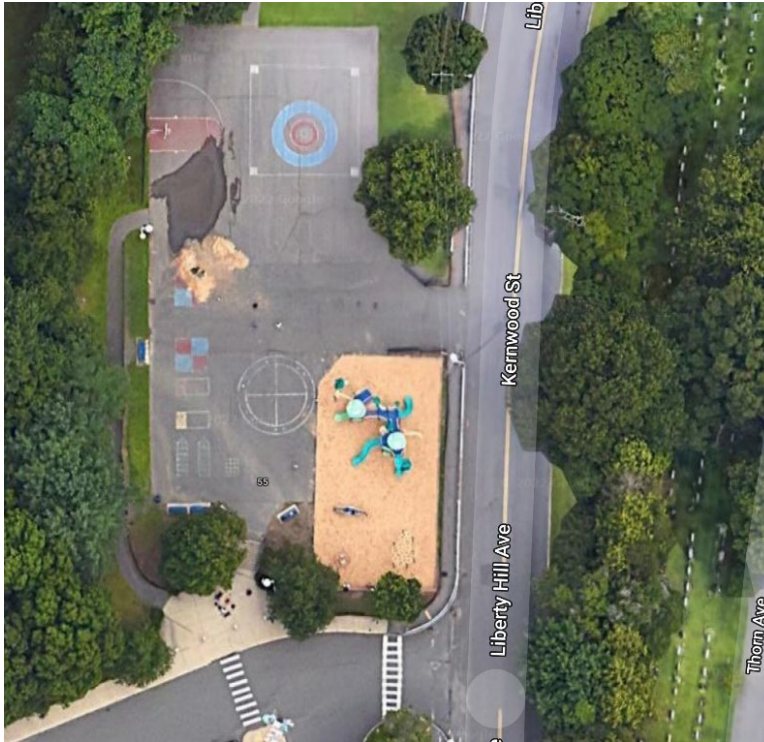

PLAYGROUND NAME:

BATES ELEMENTARY
SCHOOL 5-12 Y.O.
PLAYGROUND

PLAYGROUND ADDRESS:

**53 Liberty Hill Ave, Salem,
MA 01970**

DATE OF SITE VISIT:

3 May 2022

MANUFACTURER/S:

Playworld

AGE APPROPRIATE:

| | | | |
|----------------------------------|--|-----------------------------------|----------------------------------|
| <input type="checkbox"/> 2-5 YRS | <input checked="" type="checkbox"/> 5-12 YRS | <input type="checkbox"/> 2-12 YRS | <input type="checkbox"/> 13+ YRS |
|----------------------------------|--|-----------------------------------|----------------------------------|

1. GENERAL SITE CONDITIONS AND APPROACH:

| | | | |
|--|-------------------------------|-------------------------------|------------------------------------|
| <input checked="" type="checkbox"/> POOR | <input type="checkbox"/> FAIR | <input type="checkbox"/> GOOD | <input type="checkbox"/> COMPLIANT |
|--|-------------------------------|-------------------------------|------------------------------------|

- *The playground sits below the road (which could be the cause of the drainage issues) with both stairs and a ramp entrance.*
- *There is a drainage issue – located diagonally from the structure. Even when the conditions are 'dry', there is water ponding near the basketball hoop.*
- *Access is not ADA compliant due to percent slope and poor asphalt conditions. Stairs are in poor conditions with gaps and level changes on horizontal pavement.*
- *Shade trees are in poor conditions with root systems exposed and visible soil erosion towards the playground area.*
- *Fence needs repair and paint or replacement; whichever is more feasible.*

2022 Playground Study Report

Prepared for the City of Salem Public Schools, in Massachusetts

2. VISUAL SURFACING REVIEW:

SURFACING TYPE(S):

| | | | | | |
|---|------------------------------|--------------------------------|-------------------------------|--------------------------------|--------------------------------|
| <input checked="" type="checkbox"/> EWF | <input type="checkbox"/> PIP | <input type="checkbox"/> TILES | <input type="checkbox"/> SAND | <input type="checkbox"/> GRASS | <input type="checkbox"/> OTHER |
|---|------------------------------|--------------------------------|-------------------------------|--------------------------------|--------------------------------|

| | | | |
|-------------------------------|--|-------------------------------|------------------------------------|
| <input type="checkbox"/> POOR | <input checked="" type="checkbox"/> FAIR | <input type="checkbox"/> GOOD | <input type="checkbox"/> COMPLIANT |
|-------------------------------|--|-------------------------------|------------------------------------|

- *Better edging is needed to contain the EWF.*
- *EWF needs to be raked on a regular basis. It is evident by the amount of EWF outside the perimeter, where the most frequently used access into the playground is.*
- *Tripping hazards are created with inconsistent depths of EWF.*

3. COMPONENT STRUCTURE REVIEW:

| | | | |
|-------------------------------|-------------------------------|--|---|
| <input type="checkbox"/> POOR | <input type="checkbox"/> FAIR | <input checked="" type="checkbox"/> GOOD | <input checked="" type="checkbox"/> COMPLIANT |
|-------------------------------|-------------------------------|--|---|

- *There is a broken panel on the structure.*
- *A wheel is missing.*

Play Equipment Inventory:

- *(4) single slides: (1) spiral*
- *(2) Talk tubes*
- *Play panels: (1) Window, (1) Drums, (1) Dynamic, (1) Spinning element*
- *Horizontal (Overhead) Corkscrew Climber*
- *Vertical access Climber with rigid rings*
- *Overhead hand spinner*
- *Transfer station*
- *Arch access Climber*

2022 Playground Study Report

Prepared for the City of Salem Public Schools, in Massachusetts

4. FREE STANDING EQUIPMENT (INCLUDING SWINGS):

| | | | |
|-------------------------------|-------------------------------|--|------------------------------------|
| <input type="checkbox"/> POOR | <input type="checkbox"/> FAIR | <input checked="" type="checkbox"/> GOOD | <input type="checkbox"/> COMPLIANT |
|-------------------------------|-------------------------------|--|------------------------------------|

- **HAZARD 1 Safety Concern:** Seesaw is broken; Owner said UltiPlay (Playworld sales rep.) will send a new one at no cost. Seesaw is not secured; the end pieces are 'eye protrusions'. Some other type of barrier should surround it rather than caution tape.
- Although Spinner is installed 6ft from edge of retaining wall, school Principal wants to remove it due to accidents at high velocity. **PINE/m3 to talk to UltiPlay for other free standing play equipment options.**
- Horizontal Overhead climber: foot holes are loose.

5. SITE AMENITIES:

| | | | |
|--|-------------------------------|-------------------------------|------------------------------------|
| <input checked="" type="checkbox"/> POOR | <input type="checkbox"/> FAIR | <input type="checkbox"/> GOOD | <input type="checkbox"/> COMPLIANT |
|--|-------------------------------|-------------------------------|------------------------------------|

- (5) steel benches- not ADA compliant (have no ADA space for wheelchairs and are not set flush with finish grade)
- (2) trash receptacles
- (1) bike rack (not in concrete pad)
- (1) Half basketball court with hoop- pavement cracked and with drainage issues (water ponding is visible)
- Fence: fabric broken, ties missing, and nonstandard substitute ties need to be replaced; some top rails need to be replaced; some post caps are missing.
- Handrails- need to be painted and post base sealed
- Sloped planted edges are in poor conditions: Tree roots are exposed, crushed stone under asphalt paving is eroding downhill to the playground pavement. Need regrading, replanting (with ground cover to control soil erosion) and proper maintenance is required to keep erosion control.
- ADA access path needs to be repaired/reconstructed, along with the adjacent chain link fence

2022 Playground Study Report

Prepared for the City of Salem Public Schools, in Massachusetts

6. SUMMARY | RECOMMENDATIONS

OVERALL CONDITION OF PLAYGROUND:

| | | | |
|-------------------------------|--|--|------------------------------------|
| <input type="checkbox"/> POOR | <input checked="" type="checkbox"/> FAIR | <input checked="" type="checkbox"/> GOOD | <input type="checkbox"/> COMPLIANT |
|-------------------------------|--|--|------------------------------------|

- *Tighten footholds on Independent Climber.*
- *Pull all EWF away from perimeter edging, as it is not needed and rake evenly to levels indicated on the play equipment posts.*
- *A 'curb cut' needs to be developed; meets ADA, but not MAAB.*
- *Add a wheel (missing) and repair panel.*
- *Consider lowering the individual horizontals (consult with PINE for clarification); so that a wider group of children can experience the play event by reaching and trying.*
- *The spinner needs to be removed. The School Principal has indicated that children cannot "hang on" and they get "thrown off" toward the retaining wall, and it is a hazard.*
- *The design of the spinner does not allow for full hand and foot control. Replace ASAP.*
- *The structure is in good condition overall; independent pieces are in fair condition due to layout and disrepair of independent play elements.*

Site repairs:

- *Sloped walkway is over the **5% long slope and 2% cross slope** ADA compliance limit (with a slope of 5.90% at the highest point). Since asphalt cracks and bumps need to be repaired, our recommendation is to address the proper slope and include a concrete/asphalt pad under the bike racks.*
- *The basketball court, asphalt repairs should address the grading and drainage issues and include a pad (space) next to at least one of the benches for a wheelchair user.*
- *Concrete stairs with cracks and gaps should also be repaired as they pose trip hazards for any able body.*
- *The chain link fence mesh should be repaired as well as the post and caps with new paint.*

2022 Playground Study Report

Prepared for the City of Salem Public Schools, in Massachusetts

- *The exposed tree roots should be covered with soil. Sloped soil berms should be aerated and planted with shade and drought tolerant groundcover to prevent soil erosion into play area and to safeguard the soil around the tree roots.*

2022 Playground Study Report

Prepared for the City of Salem Public Schools, in Massachusetts

7. PLAYGROUND PHOTOGRAPHS:

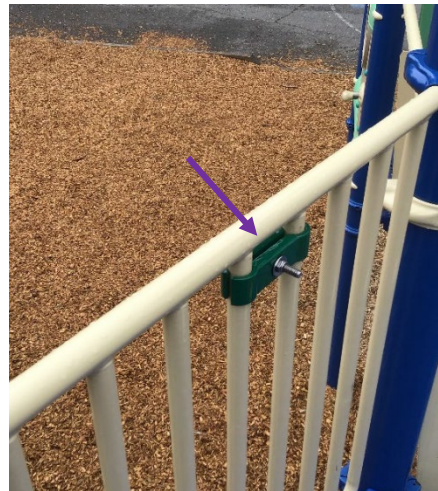

2022 Playground Study Report

Prepared for the City of Salem Public Schools, in Massachusetts

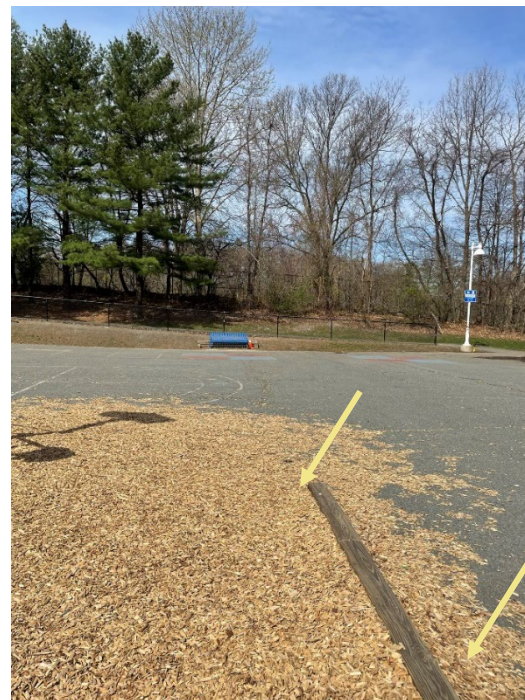
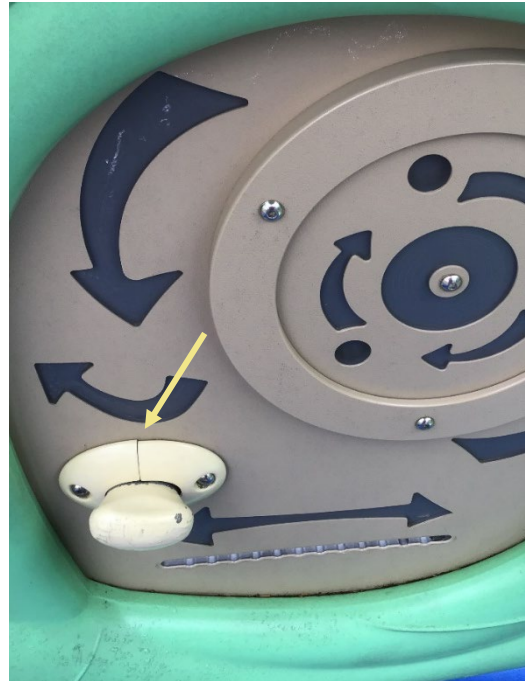

2022 Playground Study Report

Prepared for the City of Salem Public Schools, in Massachusetts

8. PLAYGROUND SITE PHOTOGRAPHS:



2022 Playground Study Report

Prepared for the City of Salem Public Schools, in Massachusetts

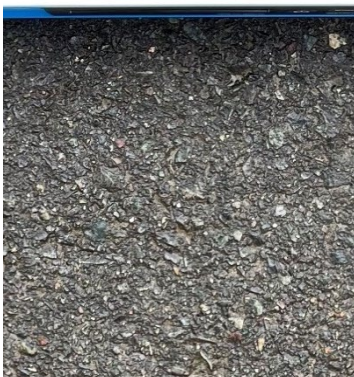
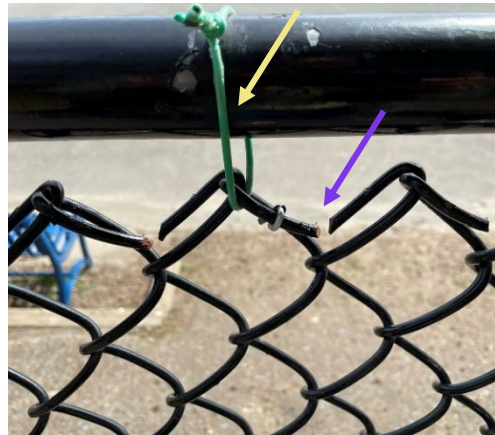

2022 Playground Study Report

Prepared for the City of Salem Public Schools, in Massachusetts

9. 2D LAYOUTS:

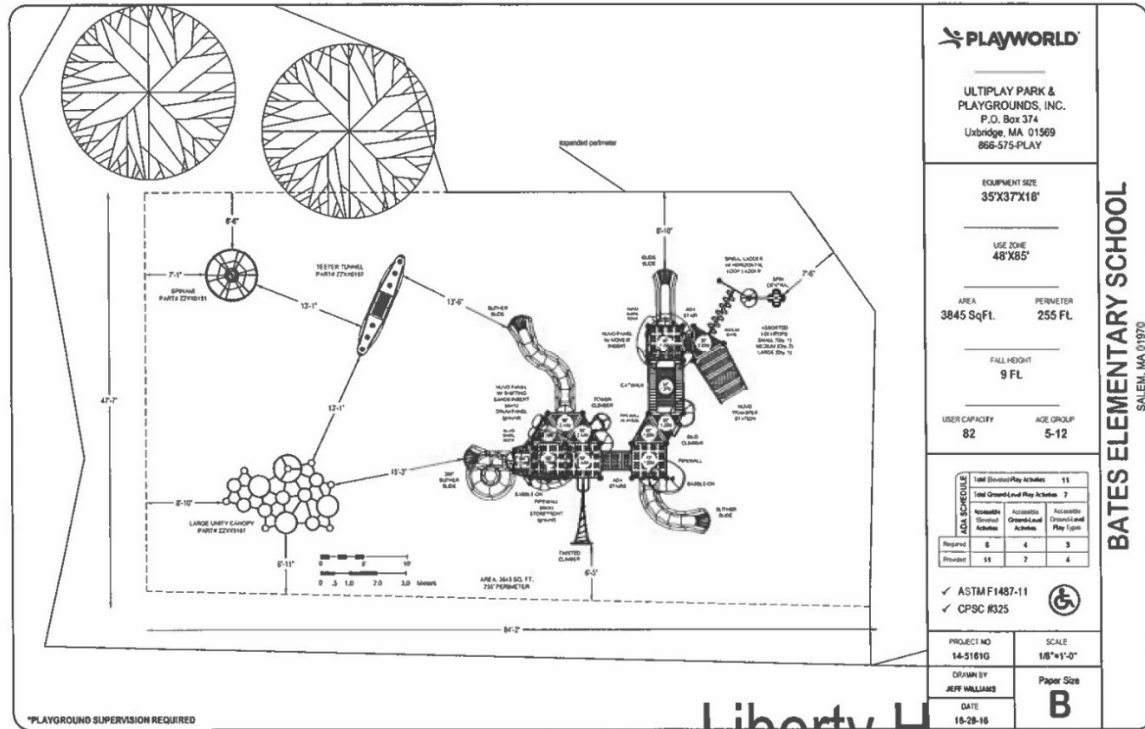
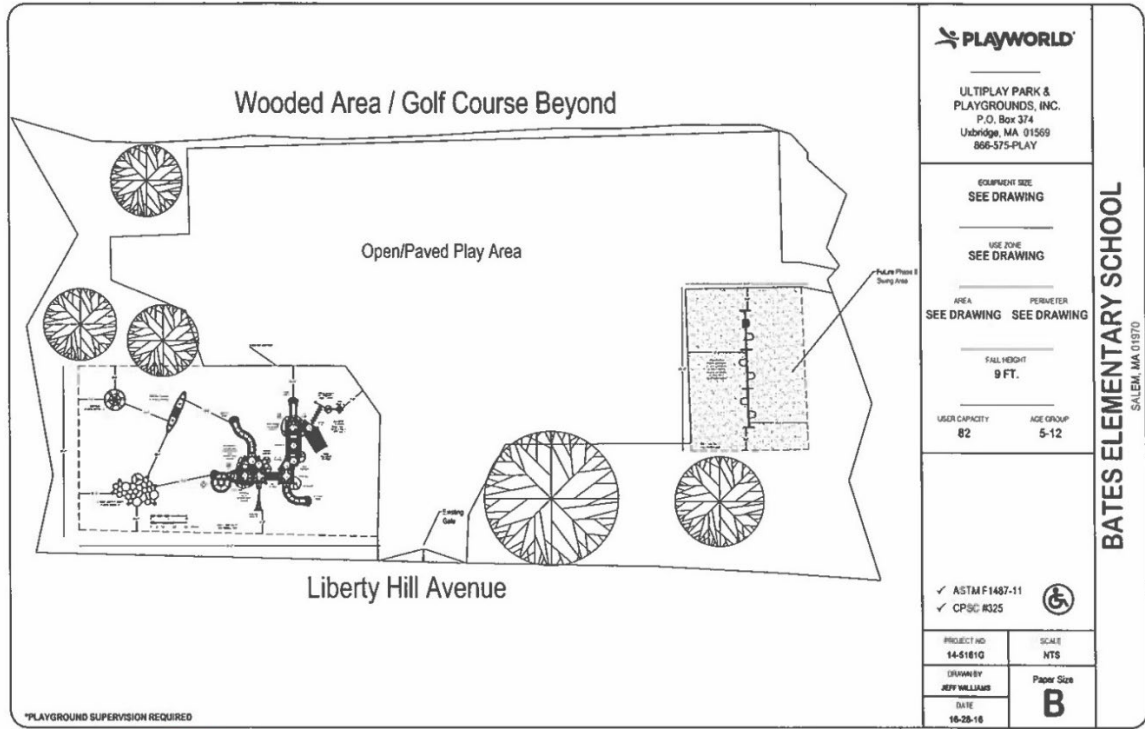

2022 Playground Study Report

Prepared for the City of Salem Public Schools, in Massachusetts

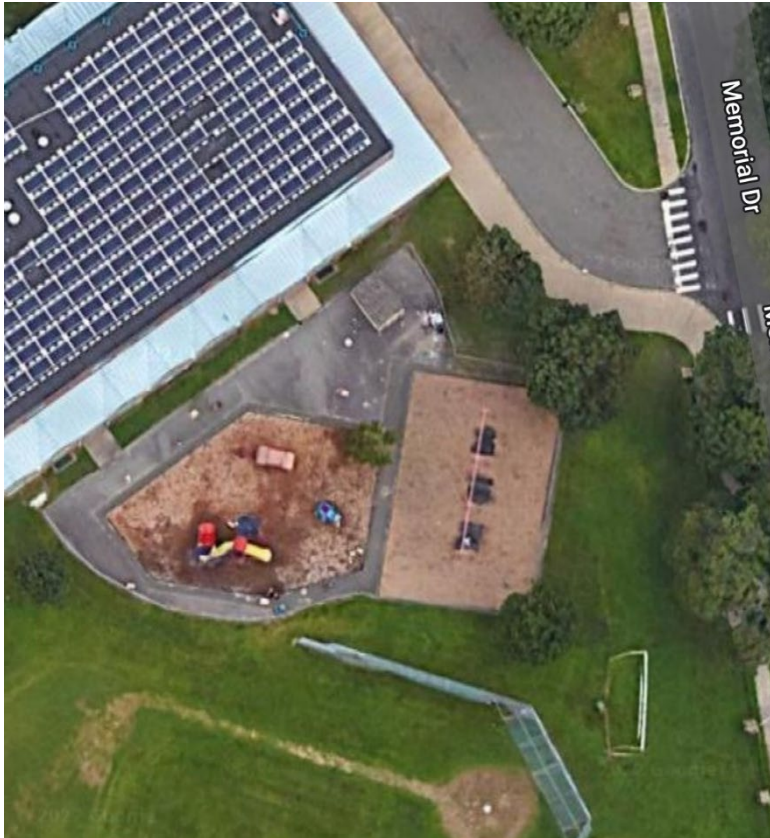

PLAYGROUND NAME:

**SALEM EARLY
CHILDHOOD SCHOOL 2-
5 Y.O. PLAYGROUND**

PLAYGROUND ADDRESS:

**25 Memorial Dr, Salem, MA
01970**

DATE OF SITE VISIT:

02 MAY 2022

MANUFACTURER/S:

**Kompan, Little Tikes &
'unknown' swing
Manufacturer**

AGE APPROPRIATE:

| | | | |
|---|-----------------------------------|-----------------------------------|----------------------------------|
| <input checked="" type="checkbox"/> X 2-5 YRS | <input type="checkbox"/> 5-12 YRS | <input type="checkbox"/> 2-12 YRS | <input type="checkbox"/> 13+ YRS |
|---|-----------------------------------|-----------------------------------|----------------------------------|

1. GENERAL SITE CONDITIONS AND APPROACH:

| | | | |
|-------------------------------|--|-------------------------------|------------------------------------|
| <input type="checkbox"/> POOR | <input checked="" type="checkbox"/> X FAIR | <input type="checkbox"/> GOOD | <input type="checkbox"/> COMPLIANT |
|-------------------------------|--|-------------------------------|------------------------------------|

- Access is good; however, it is not ADA compliant for universal use. (From the street sidewalk, ramp slopes > 5% and the vehicular access gates are tied up with string. From the (2) classroom doors there are +/-4" steps into the pedestrian gates which makes these routes not compliant for universal access).*
- The play area is 'wide open', exposed to sun and wind, and there is very little play equipment.*

2022 Playground Study Report

Prepared for the City of Salem Public Schools, in Massachusetts

- *PIP temperatures can reach up to 125 degrees without shade. This is a hazardous setting without shade. (Shade is required for Pre-K by the State of Massachusetts).*

2. VISUAL SURFACING REVIEW:

SURFACING TYPE(S):

| | | | | | |
|------------------------------|---|--------------------------------|-------------------------------|--------------------------------|--------------------------------------|
| <input type="checkbox"/> EWF | <input checked="" type="checkbox"/> PIP | <input type="checkbox"/> TILES | <input type="checkbox"/> SAND | <input type="checkbox"/> GRASS | <input type="checkbox"/> OTHER _____ |
|------------------------------|---|--------------------------------|-------------------------------|--------------------------------|--------------------------------------|

| | | | |
|--|-------------------------------|--|------------------------------------|
| <input checked="" type="checkbox"/> POOR | <input type="checkbox"/> FAIR | <input checked="" type="checkbox"/> GOOD | <input type="checkbox"/> COMPLIANT |
|--|-------------------------------|--|------------------------------------|

- *The PIP surfacing is in good condition.*
- *PIP- not compliant under swings (lack of minimal surface area under swings).*

3. COMPONENT STRUCTURE REVIEW: N/A

| | | | |
|-------------------------------|-------------------------------|-------------------------------|------------------------------------|
| <input type="checkbox"/> POOR | <input type="checkbox"/> FAIR | <input type="checkbox"/> GOOD | <input type="checkbox"/> COMPLIANT |
|-------------------------------|-------------------------------|-------------------------------|------------------------------------|

NOTE: No structure: all play equipment is free-standing.

4. FREE STANDING EQUIPMENT (INCLUDING SWINGS):

| | | | |
|--|-------------------------------|--|------------------------------------|
| <input checked="" type="checkbox"/> POOR | <input type="checkbox"/> FAIR | <input checked="" type="checkbox"/> GOOD | <input type="checkbox"/> COMPLIANT |
|--|-------------------------------|--|------------------------------------|

- **HAZARD 1 Safety Concern:** *One of the swings is a 'wheelchair metal swing'. It does not meet ASTM or CPSC – and is NOT suitable in a public setting. Remove ASAP.*
- *Other swings have old chains that need replacement. Safety surfacing is insufficient (see surfacing above).*
- *The tunnel, sand table, and spinner are in good condition.*

Play Equipment Inventory:

- *(3) Swing bays: (1) ADA adaptable seat, (2) belt seats, and (1) Wheelchair metal swing*
- *Balance beam- was only visible on the first site visit*
- *Spinner by Kompan*
- *Crawl tunnel by Kompan*

2022 Playground Study Report

Prepared for the City of Salem Public Schools, in Massachusetts

- *Play table by Kompan*

5. SITE AMENITIES:

| | | | |
|-------------------------------|--|-------------------------------|------------------------------------|
| <input type="checkbox"/> POOR | <input checked="" type="checkbox"/> FAIR | <input type="checkbox"/> GOOD | <input type="checkbox"/> COMPLIANT |
|-------------------------------|--|-------------------------------|------------------------------------|

- *Child Picnic Table by Little Tikes*
- *Storage shed- good condition (visible from outside)*
- *Fence - needs to be updated, has a poor safety lock, posts need caps, and some top rails need repair (see photos).*
- *There is a lack of shade trees or shade structures.*
- *There is a lack of seating for adult supervision.*

6. SUMMARY | RECOMMENDATIONS

OVERALL CONDITION OF PLAYGROUND:

| | | | |
|-------------------------------|--|-------------------------------|------------------------------------|
| <input type="checkbox"/> POOR | <input checked="" type="checkbox"/> FAIR | <input type="checkbox"/> GOOD | <input type="checkbox"/> COMPLIANT |
|-------------------------------|--|-------------------------------|------------------------------------|

- *Remove the 'wheelchair' swing: this can cause blunt trauma. Note: ADA wheelchair swing needs to be used under adult supervision as it is considered a **hazard 1** in public playgrounds.*
- *Swings have a use zone total of 8' in the 'to motion' and 8' in the 'fro motion'. The total should be 16' in front, and 16' in back; thus the PIP is 16' short (Use Zone for swings should be double the height of the swing structure²). The coated chain on the swings needs to be replaced.*
- *Playground site in general is in good condition but lacks cohesion and needs play value (Play components are spread out with lots of asphalt pavement in between). Sensory panels can be installed through asphalt and do not need a use zone. Consider this as an add-on for play value.*

² CPSC Public Playground Safety Handbook; See § 5.3.8.3.3, p39-40

2022 Playground Study Report

Prepared for the City of Salem Public Schools, in Massachusetts

- *Balance beam- needs to be removed or repaired.*
- *Add a shade structure/ shade trees.*
- *Repair fence and consider adding a 'sloped walkway' from one of the classroom doors for ADA*

2022 Playground Study Report
Prepared for the City of Salem Public Schools, in Massachusetts

7. PLAYGROUND PHOTOGRAPHS:



2022 Playground Study Report

Prepared for the City of Salem Public Schools, in Massachusetts

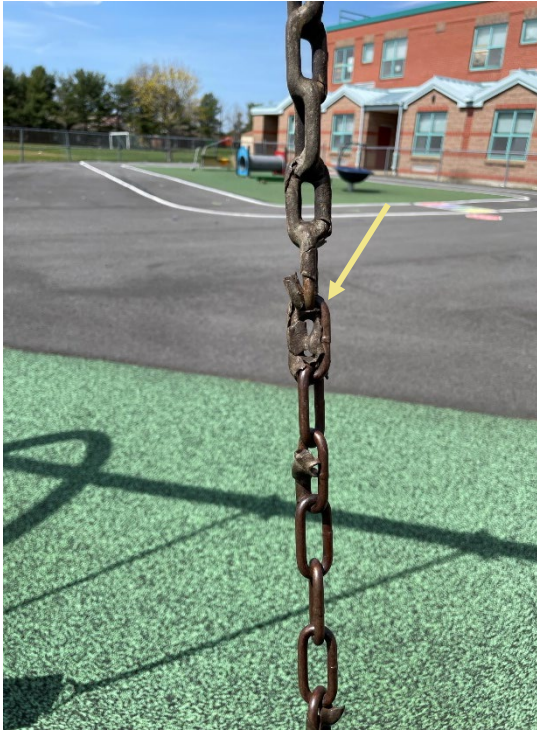

2022 Playground Study Report

Prepared for the City of Salem Public Schools, in Massachusetts

8. PLAYGROUND SITE PHOTOGRAPHS:

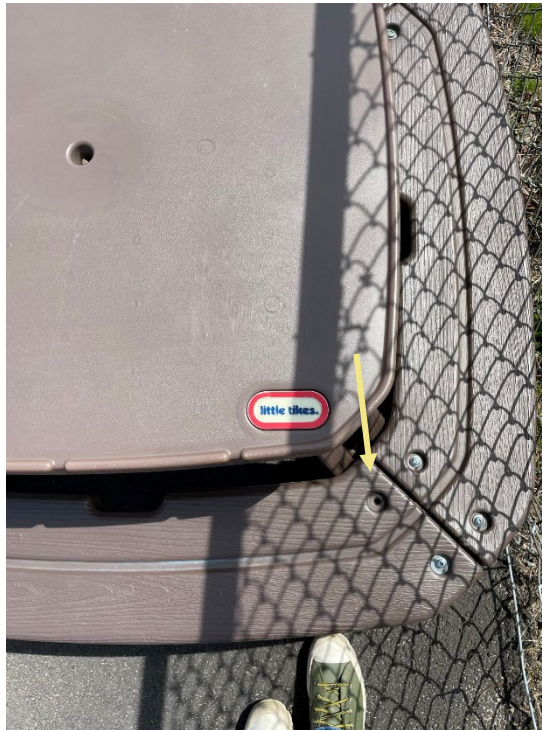
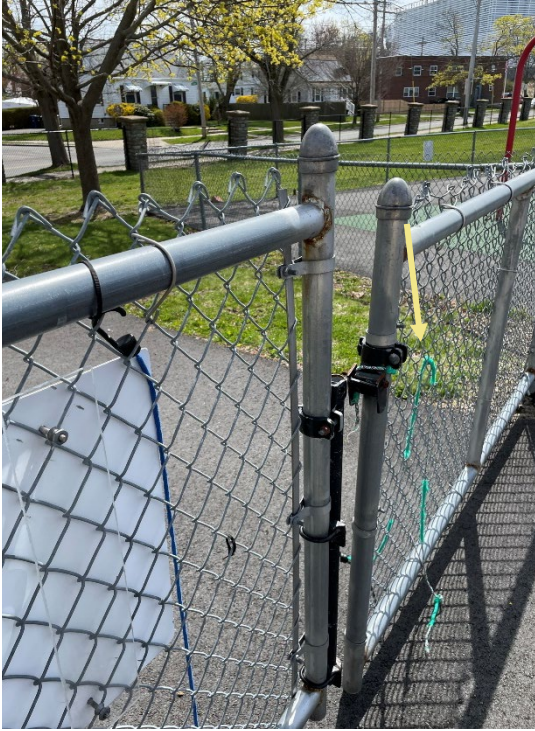

2022 Playground Study Report

Prepared for the City of Salem Public Schools, in Massachusetts



PLAYGROUND NAME:

BENTLEY ACADEMY
INNOVATION SCHOOL 5-
12 Y.O. PLAYGROUND

PLAYGROUND ADDRESS:

25 Memorial Dr, Salem, MA
01970

DATE OF SITE VISIT:

02 MAY 2022

MANUFACTURER/S:

LSI

AGE APPROPRIATE:

| | | | |
|----------------------------------|--|-----------------------------------|----------------------------------|
| <input type="checkbox"/> 2-5 YRS | <input checked="" type="checkbox"/> 5-12 YRS | <input type="checkbox"/> 2-12 YRS | <input type="checkbox"/> 13+ YRS |
|----------------------------------|--|-----------------------------------|----------------------------------|

1. GENERAL SITE CONDITIONS AND APPROACH:

| | | | |
|-------------------------------|--|-------------------------------|------------------------------------|
| <input type="checkbox"/> POOR | <input checked="" type="checkbox"/> FAIR | <input type="checkbox"/> GOOD | <input type="checkbox"/> COMPLIANT |
|-------------------------------|--|-------------------------------|------------------------------------|

- The play equipment is in a good location; but the asphalt is in fair-poor condition. The asphalt has many cracks and needs repair; there are patches and uneven areas throughout the pavement that create tripping hazards.*
- Playground is adequately enclosed (fenced with 2 pedestrian gates but missing gate locks).*
- Shade is lacking and is strongly recommended as this is an exposed site with no trees near the playground, especially during the extreme summer months.*

2022 Playground Study Report

Prepared for the City of Salem Public Schools, in Massachusetts

- *Access is not ADA compliant from the school access doors (All doorway landings have a 3" to 4" step down to the asphalt pavement or finish grade. All playground safety surfacing is raised around 6" from finish grade.*

2. VISUAL SURFACING REVIEW:

SURFACING TYPE(S):

| | | | | | |
|------------------------------|---|--------------------------------|-------------------------------|--------------------------------|--------------------------------------|
| <input type="checkbox"/> EWF | <input checked="" type="checkbox"/> PIP | <input type="checkbox"/> TILES | <input type="checkbox"/> SAND | <input type="checkbox"/> GRASS | <input type="checkbox"/> OTHER _____ |
|------------------------------|---|--------------------------------|-------------------------------|--------------------------------|--------------------------------------|

| | | | |
|-------------------------------|--|--|------------------------------------|
| <input type="checkbox"/> POOR | <input checked="" type="checkbox"/> FAIR | <input checked="" type="checkbox"/> GOOD | <input type="checkbox"/> COMPLIANT |
|-------------------------------|--|--|------------------------------------|

- *The intent for ADA access was attempted and is incorrect. The slope is over 5.6% and needs to be **less than 5% to not require handrails**. Since the 'granules' are coming off the PIP, their repair could include fixing the overall pavement and the regrading of the accessible slope up, towards the play equipment to be **less than 5%**.*
- *A piece of PIP has pulled up and that will continue to rip, as children play in the area. There are also 'granules' under some of the components.*
- *Some PIP edges are eroding, also under some play equipment. (Needs a second coat of polyurethane to prevent the EPDM granules from wearing away).*

3. COMPONENT STRUCTURE REVIEW:

| | | | |
|-------------------------------|-------------------------------|--|---|
| <input type="checkbox"/> POOR | <input type="checkbox"/> FAIR | <input checked="" type="checkbox"/> GOOD | <input checked="" type="checkbox"/> COMPLIANT |
|-------------------------------|-------------------------------|--|---|

- *The chain ladder is missing some rungs. All hardware that is part of the rung connections should be removed until replaced.*
- *Touch up paint in some areas is needed.*
- *Placement/layout of play equipment is adequate and is fairly new (2017)*

Play Equipment Inventory:

- (1) Double slide

2022 Playground Study Report

Prepared for the City of Salem Public Schools, in Massachusetts

- (1) *Single slide*
- (1) *Play panel*
- (4) *Step (vertical) ladders*
- (4) *Overhead (horizontal) climbers*
- (6) *Bridges*
- (5) *Benches (integrated into play structure)*
- (1) *Net climber*
- (1) *Spinner*
- (4) *Connecting pods*
- (1) *Tight rope*

4. FREE STANDING EQUIPMENT (INCLUDING SWINGS):

| | | | |
|-------------------------------|-------------------------------|-------------------------------|---|
| <input type="checkbox"/> POOR | <input type="checkbox"/> FAIR | <input type="checkbox"/> GOOD | <input checked="" type="checkbox"/> COMPLIANT |
|-------------------------------|-------------------------------|-------------------------------|---|

- *The freestanding equipment is in good condition.*

Play Equipment Inventory:

- (1) *Balance beam*
- (1) *Swing bay*
- (3) *Play panels*

5. SITE AMENITIES:

| | | | |
|-------------------------------|-------------------------------|--|---|
| <input type="checkbox"/> POOR | <input type="checkbox"/> FAIR | <input checked="" type="checkbox"/> GOOD | <input checked="" type="checkbox"/> COMPLIANT |
|-------------------------------|-------------------------------|--|---|

- (4) *Benches | Benches are compliant.*
- (1) *Trash receptacle*

2022 Playground Study Report

Prepared for the City of Salem Public Schools, in Massachusetts

- (4) *Playground signs*
- (1) *Shade structure*
- *Fence with (2) gates. Both gates need new safety latch.*
- *Asphalt paving with painted games- in poor conditions. Needs crack repairs throughout and leveling to avoid tripping hazards and provide ADA access and enjoyment for all.*

6. SUMMARY | RECOMMENDATIONS

OVERALL CONDITION OF PLAYGROUND:

| | | | |
|-------------------------------|-------------------------------|--|------------------------------------|
| <input type="checkbox"/> POOR | <input type="checkbox"/> FAIR | <input checked="" type="checkbox"/> GOOD | <input type="checkbox"/> COMPLIANT |
|-------------------------------|-------------------------------|--|------------------------------------|

- *Swing bay- belt swing chains need grease (make noise when swinging).*
- *Fence with (2) gates. Both gates need new safety latch (instead of ribbon)*
- *The chain ladder is missing some rungs. All hardware that is part of the rung connections should be removed until replaced.*
- *Overall, integrity of the PIP surfacing is in question due to granules and the worn sections. Suggest speaking with the Manufacturers Rep to see what may have caused this (i.e.: failing materials or installation). If installation is less than 5 years – the materials could be under warranty. Unsure about the 'labor warranty'.*

2022 Playground Study Report

Prepared for the City of Salem Public Schools, in Massachusetts

7. PLAYGROUND PHOTOGRAPHS:



2022 Playground Study Report

Prepared for the City of Salem Public Schools, in Massachusetts



2022 Playground Study Report
Prepared for the City of Salem Public Schools, in Massachusetts

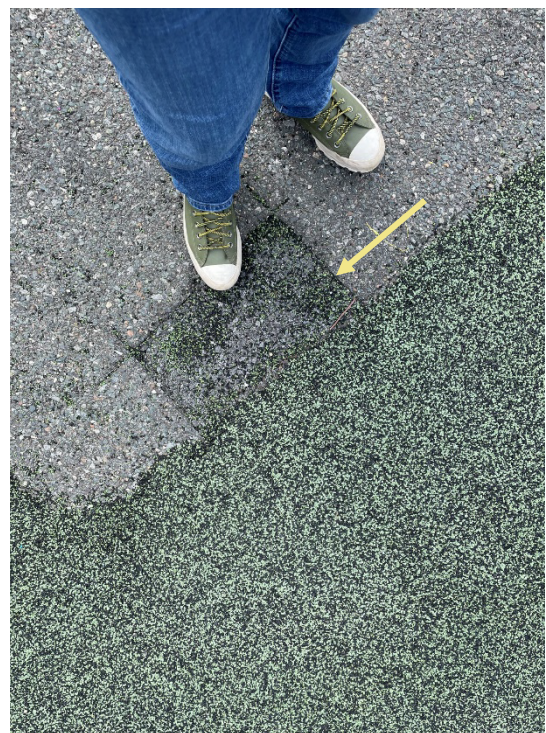

2022 Playground Study Report
Prepared for the City of Salem Public Schools, in Massachusetts

8. PLAYGROUND SITE PHOTOGRAPHS:

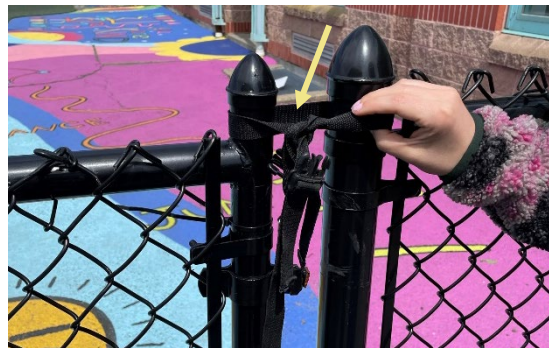

2022 Playground Study Report

Prepared for the City of Salem Public Schools, in Massachusetts



2022 Playground Study Report

Prepared for the City of Salem Public Schools, in Massachusetts

9. 2D LAYOUTS:

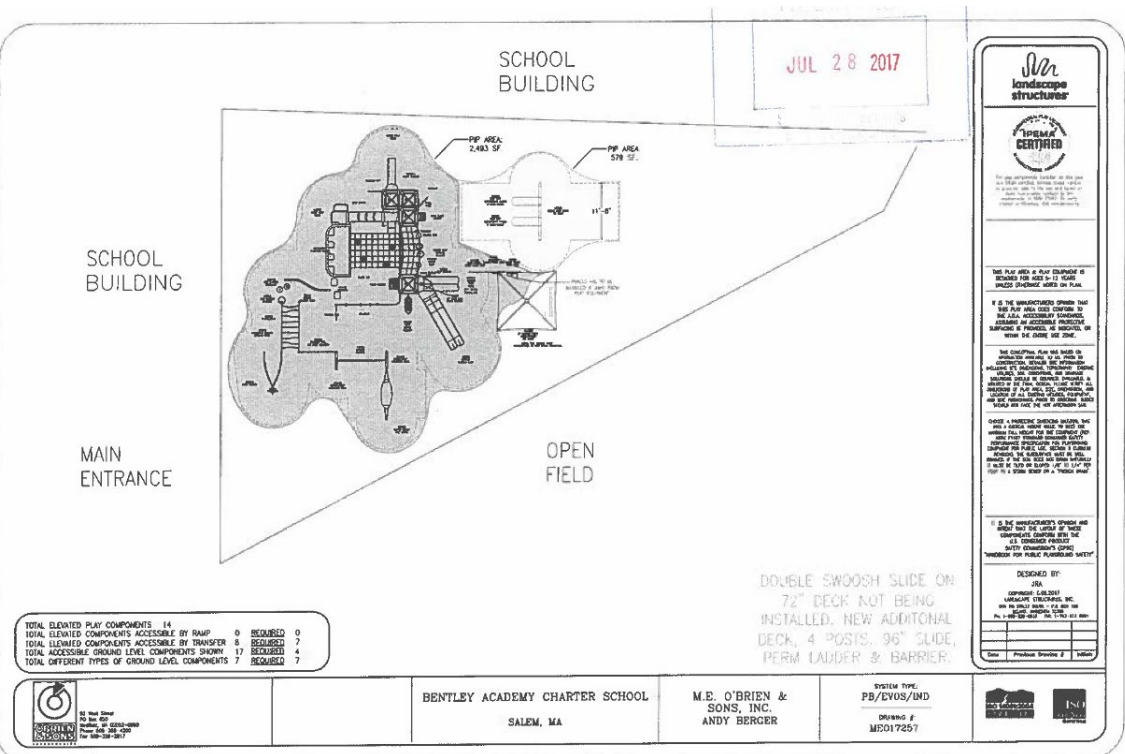
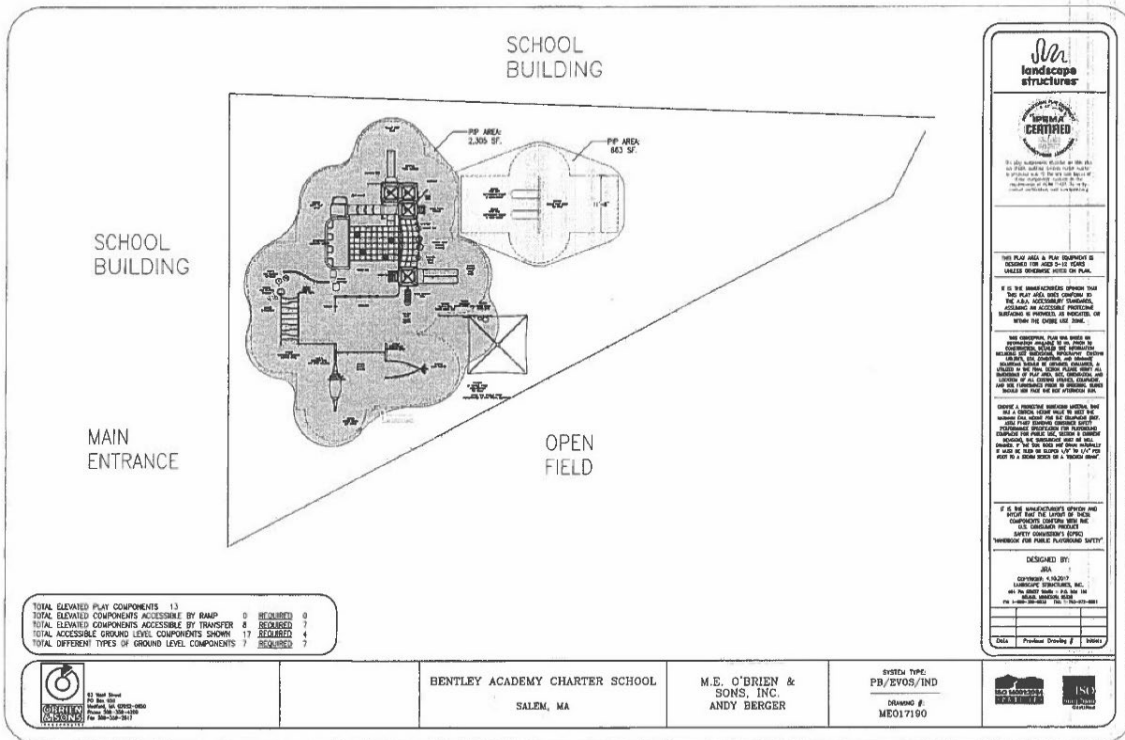

2022 Playground Study Report

Prepared for the City of Salem Public Schools, in Massachusetts

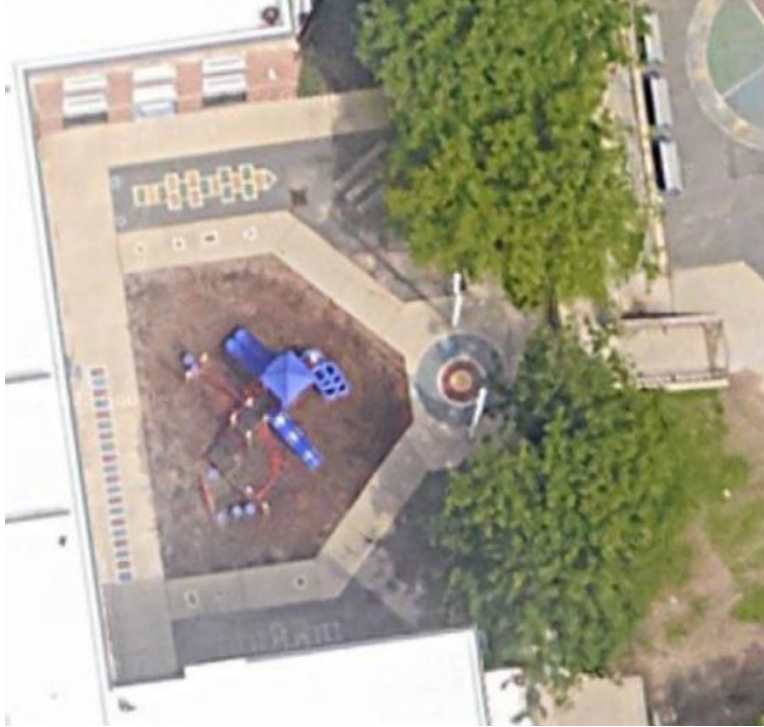

PLAYGROUND NAME:

SALTONSTALL SCHOOL
KINDERGARTEN
PLAYGROUND

PLAYGROUND ADDRESS:

211 Lafayette St, Salem, MA
01970

DATE OF SITE VISIT:

03 May 2022

MANUFACTURER/S:

Playland

AGE APPROPRIATE:

| | | | |
|----------------------------------|--|-----------------------------------|----------------------------------|
| <input type="checkbox"/> 2-5 YRS | <input checked="" type="checkbox"/> 5-12 YRS | <input type="checkbox"/> 2-12 YRS | <input type="checkbox"/> 13+ YRS |
|----------------------------------|--|-----------------------------------|----------------------------------|

1. GENERAL SITE CONDITIONS AND APPROACH:

| | | | |
|-------------------------------|--|-------------------------------|------------------------------------|
| <input type="checkbox"/> POOR | <input checked="" type="checkbox"/> FAIR | <input type="checkbox"/> GOOD | <input type="checkbox"/> COMPLIANT |
|-------------------------------|--|-------------------------------|------------------------------------|

- *Good access from all sides.*
- *Attractive location because it is in a courtyard.*
- *Accessibility route of travel is in fair conditions, as some of the concrete pavement is broken and caving down.*
- *Playground is in fair condition but lacks cohesion and needs play value (Play components are tightly spaces in small a small area with poor play equipment design for users).*

2022 Playground Study Report

Prepared for the City of Salem Public Schools, in Massachusetts

2. VISUAL SURFACING REVIEW:

SURFACING TYPE(S):

| | | | | | |
|---|------------------------------|--------------------------------|-------------------------------|---|--------------------------------|
| <input checked="" type="checkbox"/> EWF | <input type="checkbox"/> PIP | <input type="checkbox"/> TILES | <input type="checkbox"/> SAND | <input checked="" type="checkbox"/> GRASSMATS | <input type="checkbox"/> OTHER |
|---|------------------------------|--------------------------------|-------------------------------|---|--------------------------------|

| | | | |
|-------------------------------|-------------------------------|-------------------------------|---|
| <input type="checkbox"/> POOR | <input type="checkbox"/> FAIR | <input type="checkbox"/> GOOD | <input checked="" type="checkbox"/> COMPLIANT |
|-------------------------------|-------------------------------|-------------------------------|---|

3. COMPONENT STRUCTURE REVIEW:

| | | | |
|-------------------------------|--|-------------------------------|------------------------------------|
| <input type="checkbox"/> POOR | <input checked="" type="checkbox"/> FAIR | <input type="checkbox"/> GOOD | <input type="checkbox"/> COMPLIANT |
|-------------------------------|--|-------------------------------|------------------------------------|

- *The user group is Kindergarten.*
- *Overhead events are too high for this user group. Lower to a maximum of 60" above finished grade. (At present height, most users do not yet have the upper body strength needed for this height).*
- *Decks should also be adjusted accordingly for this user group. Install may be incorrect in deck heights as the height of decks in some areas are too high, yet the transfer height is correct.*
- *There are rusted areas at transfer.*
- *Poor design with two climbers intersecting one another.*

Play Equipment Inventory:

- *(4) Vertical climbers*
- *(2) Horizontal*
- *(2) Slides (1 double, 1 single)*
- *(6) Pods*
- *(1) Bench panel*
- *(1) Balance beam*

2022 Playground Study Report

Prepared for the City of Salem Public Schools, in Massachusetts

4. FREE STANDING EQUIPMENT (INCLUDING SWINGS): N/A

| | | | |
|-------------------------------|-------------------------------|-------------------------------|------------------------------------|
| <input type="checkbox"/> POOR | <input type="checkbox"/> FAIR | <input type="checkbox"/> GOOD | <input type="checkbox"/> COMPLIANT |
|-------------------------------|-------------------------------|-------------------------------|------------------------------------|

5. SITE AMENITIES:

| | | | |
|-------------------------------|--|-------------------------------|------------------------------------|
| <input type="checkbox"/> POOR | <input checked="" type="checkbox"/> FAIR | <input type="checkbox"/> GOOD | <input type="checkbox"/> COMPLIANT |
|-------------------------------|--|-------------------------------|------------------------------------|

- *One bench is heaving – possible incorrect installation.*
- *The bench has damage and was placed too far from the playground (into the planting area, creating soil erosion due to constant access to it).*

6. SUMMARY | RECOMMENDATIONS

OVERALL CONDITION OF PLAYGROUND:

| | | | |
|-------------------------------|--|-------------------------------|------------------------------------|
| <input type="checkbox"/> POOR | <input checked="" type="checkbox"/> FAIR | <input type="checkbox"/> GOOD | <input type="checkbox"/> COMPLIANT |
|-------------------------------|--|-------------------------------|------------------------------------|

- *Consider changing one of the two climbing components on the deck. It is very crowded and creates a hazard in proximity. In my professional opinion, a 'square' deck would have been better.*
- *Deck heights need to be reviewed and if needed, adjust accordingly.*
- *Lower decks and overhead event for the age group. Currently, 84" is too high. Adjust to between 60" and 65".*
- *Patch the rusted areas at the transfer module.*
- *In my professional opinion, there was a poor design at the Tri Deck. Consider removal of one climber and add a balcony deck for more space on the structure.*
- *Repair broken pavement throughout; move bench close to pavement and extend concrete to create a 'pad under the bench'. A new slat on the back is needed due to the damage (or order a new bench and remove existing bench).*
- *Replant planting areas to avoid increase soil erosion.*

2022 Playground Study Report

Prepared for the City of Salem Public Schools, in Massachusetts

7. PLAYGROUND SITE PHOTOGRAPHS:



2022 Playground Study Report

Prepared for the City of Salem Public Schools, in Massachusetts



2022 Playground Study Report

Prepared for the City of Salem Public Schools, in Massachusetts

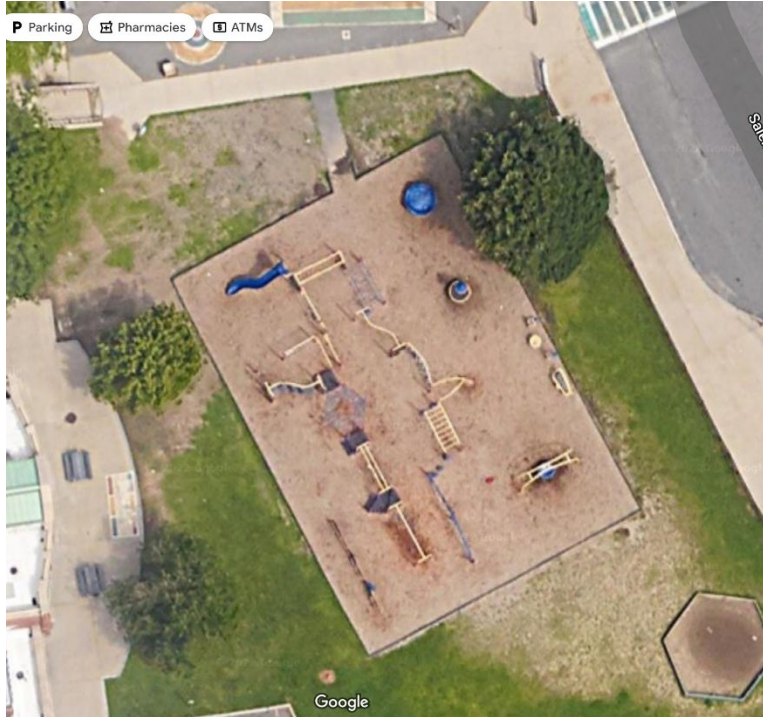

PLAYGROUND NAME:

SALTONSTALL SCHOOL 5-12 Y.O. PLAYGROUND

PLAYGROUND ADDRESS:

211 Lafayette St, Salem, MA 01970

DATE OF SITE VISIT:

2 May 2022

MANUFACTURER/S:

LSI

AGE APPROPRIATE:

| | | | |
|----------------------------------|--|-----------------------------------|----------------------------------|
| <input type="checkbox"/> 2-5 YRS | <input checked="" type="checkbox"/> 5-12 YRS | <input type="checkbox"/> 2-12 YRS | <input type="checkbox"/> 13+ YRS |
|----------------------------------|--|-----------------------------------|----------------------------------|

1. GENERAL SITE CONDITIONS AND APPROACH:

| | | | |
|-------------------------------|--|--|------------------------------------|
| <input type="checkbox"/> POOR | <input checked="" type="checkbox"/> FAIR | <input checked="" type="checkbox"/> GOOD | <input type="checkbox"/> COMPLIANT |
|-------------------------------|--|--|------------------------------------|

- *Shade trees around the playground have roots exposed due to soil erosion ('Desire lines': the shortest or most easily navigated route between an origin and destination).*
- *The play equipment is 'spread out' and is visually attractive. Site lines are excellent.*
- *A shade pavilion beyond the equipment allows for a very good balance as the playground is open to the sun.*
- *Access from the school to this playground is challenging, as it is situated at the bottom of the school slopes. There is only one ADA access point from Salem Street (across from Palmer Cover Park). Furthermore, the ramp into the school playground is very steep to be ADA compliant and has displaced EWF towards the main walkway, creating a tripping hazard, even for the able bodies. From the school, or other site amenities (such as the*

2022 Playground Study Report

Prepared for the City of Salem Public Schools, in Massachusetts

basketball court or the outdoor picnic tables) there is no direct or connecting paved paths, leading to multiple eroded path lines on the lawn and planted areas. (See above 'Desire lines' note.)

2. VISUAL SURFACING REVIEW:

SURFACING TYPE(S):

| | | | | | |
|---|------------------------------|--------------------------------|-------------------------------|---|---|
| <input checked="" type="checkbox"/> EWF | <input type="checkbox"/> PIP | <input type="checkbox"/> TILES | <input type="checkbox"/> SAND | <input checked="" type="checkbox"/> GRASSMATS | <input type="checkbox"/> OTHER _____ |
|---|------------------------------|--------------------------------|-------------------------------|---|---|

| | | | |
|-------------------------------|-------------------------------|--|------------------------------------|
| <input type="checkbox"/> POOR | <input type="checkbox"/> FAIR | <input checked="" type="checkbox"/> GOOD | <input type="checkbox"/> COMPLIANT |
|-------------------------------|-------------------------------|--|------------------------------------|

- *The perimeter edging is in good condition.*
- *The EWF is a loose fill material, and the grass mats are unitary.*
- *The EWF 'mounds up' in certain areas, then splays in other areas. This has led to tripping hazards.*

3. COMPONENT STRUCTURE REVIEW:

| | | | |
|-------------------------------|-------------------------------|--|---|
| <input type="checkbox"/> POOR | <input type="checkbox"/> FAIR | <input checked="" type="checkbox"/> GOOD | <input checked="" type="checkbox"/> COMPLIANT |
|-------------------------------|-------------------------------|--|---|

- *All equipment is in good condition.*
- *The slide exit is too long and needs adjustment. The slide exit should be between 7" - 15" and is well above that.*
- *Balance balls are dragging.*

Play Equipment Inventory:

- *(5) climbers*
- *(6) horizontal climbers*
- *(7) pods*
- *(2) bars*

2022 Playground Study Report

Prepared for the City of Salem Public Schools, in Massachusetts

- (1) *slide with climber*
- (1) *spinner*

4. FREE STANDING EQUIPMENT (INCLUDING SWINGS):

| | | | |
|-------------------------------|-------------------------------|-------------------------------|---|
| <input type="checkbox"/> POOR | <input type="checkbox"/> FAIR | <input type="checkbox"/> GOOD | <input checked="" type="checkbox"/> COMPLIANT |
|-------------------------------|-------------------------------|-------------------------------|---|

- *All individual pieces are in excellent condition.*

Play Equipment Inventory:

- (6) *play panels*
- (2) *spinners*
- (4) *music pieces*
- (1) *basket swing*
- (1) *hand spinner*
- (1) *Gaga pit*

5. SITE AMENITIES:

| | | | |
|-------------------------------|-------------------------------|--|------------------------------------|
| <input type="checkbox"/> POOR | <input type="checkbox"/> FAIR | <input checked="" type="checkbox"/> GOOD | <input type="checkbox"/> COMPLIANT |
|-------------------------------|-------------------------------|--|------------------------------------|

- (3) *benches- need replacement of some slats*
- (2) *flagpoles*
- (3) *picnic tables*
- (1) *shade structure*
- (1) *trash receptacle*
- (1) *storage shed*

2022 Playground Study Report

Prepared for the City of Salem Public Schools, in Massachusetts

6. SUMMARY | RECOMMENDATIONS

OVERALL CONDITION OF PLAYGROUND:

| | | | |
|-------------------------------|-------------------------------|--|------------------------------------|
| <input type="checkbox"/> POOR | <input type="checkbox"/> FAIR | <input checked="" type="checkbox"/> GOOD | <input type="checkbox"/> COMPLIANT |
|-------------------------------|-------------------------------|--|------------------------------------|

- *EWF that is a tripping hazard with the mats must be level out so the transition of mat to EWF is smooth/flush. This will have to be monitored monthly and will require raking.*
- *The spinner has EWF as its surfacing, thus when children are spinning, the freestanding piece creates a gully all the way around the spinner. This is a tripping hazard. Note: there are 'circular mats' to avoid this situation.*
- *The balance balls need to be reset.*
- *The slide exit should be between 7" - 15" and is well above that. Rake EWF outward too smooth and consider a wear mat.*
- *Most site amenities are in good condition.*
- *The moveable table under the shade structure are not meant to be 'outside tables'. Consider standard picnic tables. They could benefit by having a firm pavement underneath (e.g.: concrete, asphalt, or pavers)*
- *The handrail and some benches are in poor condition and may need to be replaced.*
- *Consider desired circulation by most students and adults and address a better (more direct) pathway to avoid further detriment to the planted berms and trees. Consider a fence type barrier or ground cover to aid with erosion. Existing trees may not survive. Review with your City Tree Warden; find out if they are in jeopardy.*

2022 Playground Study Report

Prepared for the City of Salem Public Schools, in Massachusetts

7. PLAYGROUND PHOTOGRAPHS:

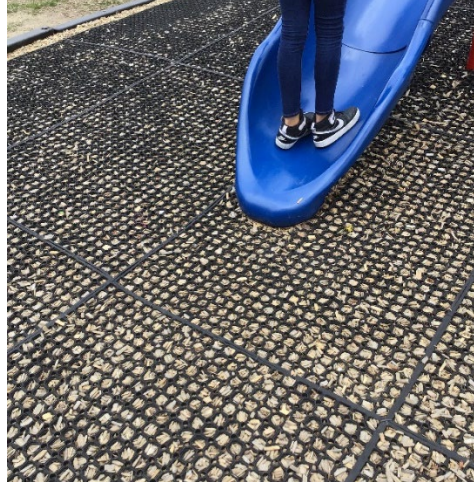

2022 Playground Study Report

Prepared for the City of Salem Public Schools, in Massachusetts

8. PLAYGROUND SITE PHOTOGRAPHS:



2022 Playground Study Report

Prepared for the City of Salem Public Schools, in Massachusetts

9. 2D LAYOUTS:

STREET

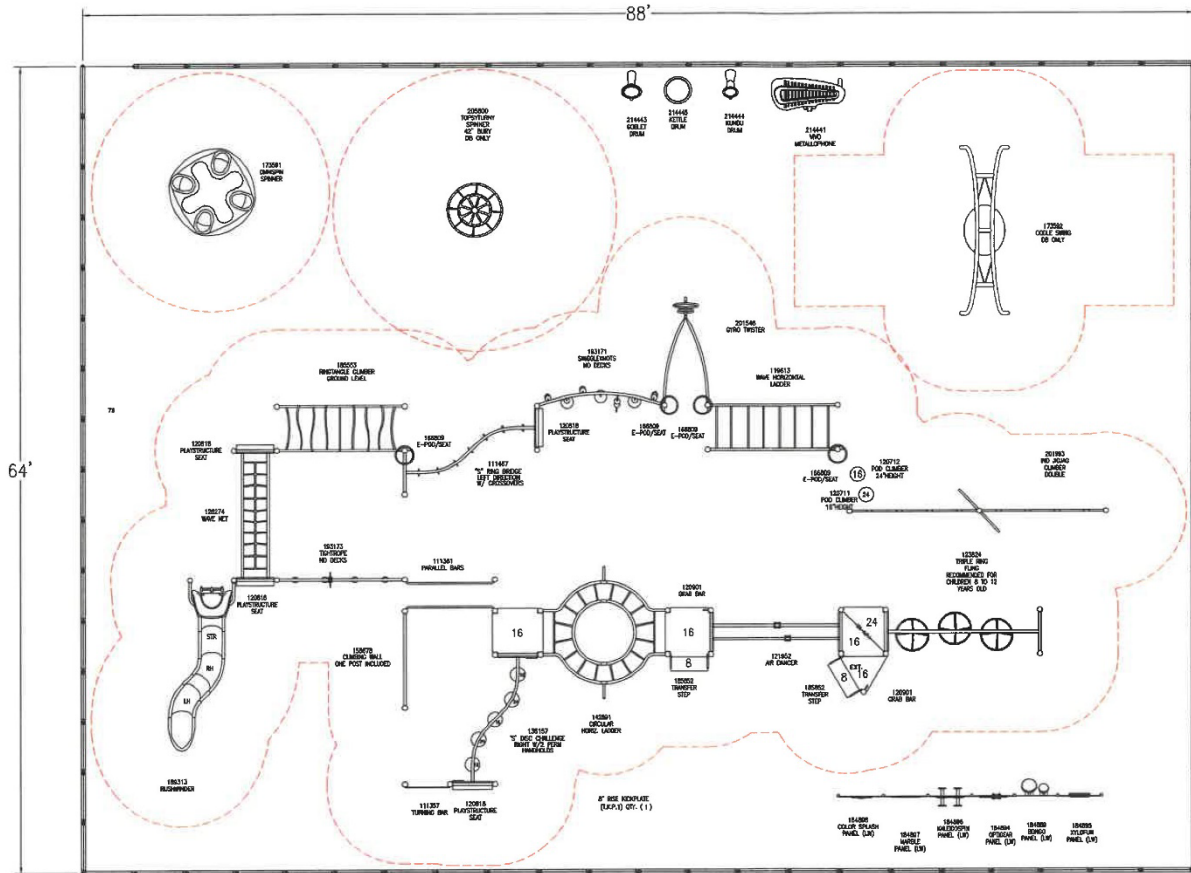

HILL

| | | | |
|---------------|----|----------|---|
| E BY RAMP | 0 | REQUIRED | 0 |
| E BY TRANSFER | 2 | REQUIRED | 2 |
| ONENTS SHOWN | 32 | REQUIRED | 1 |
| EL COMPONENTS | 9 | REQUIRED | 9 |

SALTONSTALL SCHOOL
SALEM, MA

M.E. O'BRIEN &
SONS, INC.
ANDY BERGER

2022 Playground Study Report

Prepared for the City of Salem Public Schools, in Massachusetts

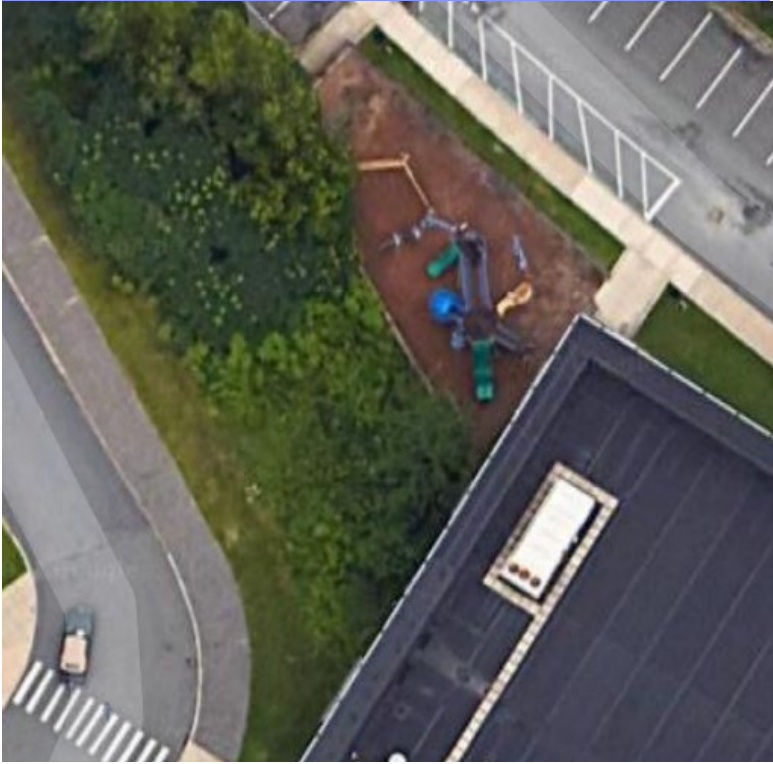

PLAYGROUND NAME:

HORACE MANN
LABORATORY SCHOOL
2-5 Y.O. PLAYGROUND

PLAYGROUND ADDRESS:

**79 Wilson St, Salem, MA
01970**

DATE OF SITE VISIT:

3 May 2022

MANUFACTURER/S:

PlayWorld

AGE APPROPRIATE:

| | | | |
|----------------------------------|---|-----------------------------------|----------------------------------|
| <input type="checkbox"/> 2-5 YRS | <input checked="" type="checkbox"/> 5-12 YRS | <input type="checkbox"/> 2-12 YRS | <input type="checkbox"/> 13+ YRS |
|----------------------------------|---|-----------------------------------|----------------------------------|

1. GENERAL SITE CONDITIONS AND APPROACH:

| | | | |
|-------------------------------|--|-------------------------------|------------------------------------|
| <input type="checkbox"/> POOR | <input checked="" type="checkbox"/> FAIR | <input type="checkbox"/> GOOD | <input type="checkbox"/> COMPLIANT |
|-------------------------------|--|-------------------------------|------------------------------------|

- *ADA ramp access from school premises has handrails and proper slope gradient.*
- *Access from the adjacent parking lot is through a concrete sidewalk and appears to be ADA compliant. (Curb cut is present on sidewalk)*
- *Site is in fair/good conditions.*
- *Playground is adequately enclosed with a concrete retaining wall and a fence, but it is lacking a pedestrian gate with a child safety latch. (See Site Amenities for fence maintenance/repair recommendations)*

2022 Playground Study Report

Prepared for the City of Salem Public Schools, in Massachusetts

- *For general maintenance recommendations see: Summary/Recommendation section below.*

2. VISUAL SURFACING REVIEW:

SURFACING TYPE(S):

| | | | | | |
|---|------------------------------|--------------------------------|-------------------------------|--------------------------------|--------------------------------|
| <input checked="" type="checkbox"/> EWF | <input type="checkbox"/> PIP | <input type="checkbox"/> TILES | <input type="checkbox"/> SAND | <input type="checkbox"/> GRASS | <input type="checkbox"/> OTHER |
|---|------------------------------|--------------------------------|-------------------------------|--------------------------------|--------------------------------|

| | | | |
|-------------------------------|--|-------------------------------|------------------------------------|
| <input type="checkbox"/> POOR | <input checked="" type="checkbox"/> FAIR | <input type="checkbox"/> GOOD | <input type="checkbox"/> COMPLIANT |
|-------------------------------|--|-------------------------------|------------------------------------|

- *Slide exits too high – EWF needs to be raked due to the amount of loose fill.*
- *Post base is exposed.*

3. COMPONENT STRUCTURE REVIEW:

| | | | |
|-------------------------------|--|-------------------------------|------------------------------------|
| <input type="checkbox"/> POOR | <input checked="" type="checkbox"/> FAIR | <input type="checkbox"/> GOOD | <input type="checkbox"/> COMPLIANT |
|-------------------------------|--|-------------------------------|------------------------------------|

- *NOTE: Vertical Corkscrew is not age appropriate for 2-5 yr. olds.*
- *Placement/layout of this play equipment is adequate.*
- *Play structures have 2 steps that are NOT acceptable for Pre-K (needs to be less than 12").*
- *Driver wheel is loose – creating a pinch point hazard.*
- *Guard rail needs to be @ 24" height.*
- *Overhead horizontal components max. height for age is 60" and only adequate for Kindergarteners. (Bring them down to 60").*
- *Rubber rocker seat/step is cracking.*
- *There is a post with an opening/crack. There is evidence that water has accumulated inside, as post is bulging out and deformed.*
- *In general, all posts need paint touchup.*

2022 Playground Study Report

Prepared for the City of Salem Public Schools, in Massachusetts

- *Check the welds.*
- *All clamps need to be painted.*
- *All verticals in general are not acceptable.*
- *Any slide greater than 6' in height needs to have an 8' use zone.*
- *Poor design of proximity of two slides; they exit into one another.*
- *Play structure is outdated and needs maintenance/repair (especially the post and post joints).*
- *Transfer station-in poor condition (rusted metal). Another Transfer station would be needed at Horizontal ladder, at end of the playground.*

Play Equipment Inventory:

- *(3) Slides: (1) Double slide, (1) Spiral slide, (1) Single slide*
- *(2) Vertical rigid climbers, (1) Vertical Corkscrew climber and (1) Step Ladder (at Diagonal Climbers)*
- *(1) Horizontal Loop Ladder, (2) Diagonal climbers and (1) Horizontal Ladder (at end)*
- *(1) Upper body bar*
- *(1) Balance beam with top bar and (1) Balance swing*
- *(1) Play panel with window and wheel, (1) Lookout area and (4) Talk tubes*

4. FREE STANDING EQUIPMENT (INCLUDING SWINGS): N/A

| | | | |
|-------------------------------|-------------------------------|-------------------------------|------------------------------------|
| <input type="checkbox"/> POOR | <input type="checkbox"/> FAIR | <input type="checkbox"/> GOOD | <input type="checkbox"/> COMPLIANT |
|-------------------------------|-------------------------------|-------------------------------|------------------------------------|

5. SITE AMENITIES:

| | | | |
|--|-------------------------------|-------------------------------|------------------------------------|
| <input checked="" type="checkbox"/> POOR | <input type="checkbox"/> FAIR | <input type="checkbox"/> GOOD | <input type="checkbox"/> COMPLIANT |
|--|-------------------------------|-------------------------------|------------------------------------|

- *(4) Benches- too high (24" from finish grade, not ADA compliant). Need paint touch up*

2022 Playground Study Report

Prepared for the City of Salem Public Schools, in Massachusetts

- *Fence- needs painting and sealing at most base of posts to avoid water ponding and rusting.*
- *Gate is missing and needs a child safety latch.*

6. SUMMARY | RECOMMENDATIONS

OVERALL CONDITION OF PLAYGROUND:

| | | | |
|-------------------------------|--|-------------------------------|------------------------------------|
| <input type="checkbox"/> POOR | <input checked="" type="checkbox"/> FAIR | <input type="checkbox"/> GOOD | <input type="checkbox"/> COMPLIANT |
|-------------------------------|--|-------------------------------|------------------------------------|

- *The structure is used by 2-5 year olds and is clearly NOT acceptable for this age group.*
- *The overhead events are too high and should be lowered.*
- *The cracked post needs to be repaired. It would be best to replace it.*
- *The vertical climbers are too high for this age group. Their bodies at this age are not ready to participate in these events.*
- *Retrofitting could be done, but not with the height but with additional panels.*
- *The climber and connectors should be removed.*
- *The horizontal circle needs to be dropped to 60" above surface.*
- *The attached vertical yellow climber needs to be removed and replaced with an easier climber for this age group.*
- *Dropping heights with the decks is not possible with the slides and the way components are connected.*
- *To retrofit – the manufacturers rep needs to redesign for age appropriateness (Pre-K).*
- *General maintenance recommendations are for the surrounding landscaping as follows: clean trash debris behind fence/wall, prune existing trees for better shade and longevity, re-seed slope edge with meadow mix or plant shrubs/groundcover for better erosion control of steep slope.*

2022 Playground Study Report

Prepared for the City of Salem Public Schools, in Massachusetts

7. PLAYGROUND PHOTOGRAPHS:



2022 Playground Study Report
Prepared for the City of Salem Public Schools, in Massachusetts



2022 Playground Study Report

Prepared for the City of Salem Public Schools, in Massachusetts

8. PLAYGROUND SITE PHOTOGRAPHS:



2022 Playground Study Report

Prepared for the City of Salem Public Schools, in Massachusetts



PLAYGROUND NAME:

HORACE MANN
LABORATORY SCHOOL 5-
12 Y.O. PLAYGROUND

PLAYGROUND ADDRESS:

79 Wilson St, Salem, MA
01970

DATE OF SITE VISIT:

03 May 2022

MANUFACTURER/S:

PlayWorld

AGE APPROPRIATE:

| | | | |
|----------------------------------|--|-----------------------------------|----------------------------------|
| <input type="checkbox"/> 2-5 YRS | <input checked="" type="checkbox"/> 5-12 YRS | <input type="checkbox"/> 2-12 YRS | <input type="checkbox"/> 13+ YRS |
|----------------------------------|--|-----------------------------------|----------------------------------|

1. GENERAL SITE CONDITIONS AND APPROACH:

| | | | |
|--|-------------------------------|-------------------------------|------------------------------------|
| <input checked="" type="checkbox"/> POOR | <input type="checkbox"/> FAIR | <input type="checkbox"/> GOOD | <input type="checkbox"/> COMPLIANT |
|--|-------------------------------|-------------------------------|------------------------------------|

- *The area is attractive and approachable with asphalt from the school.*
- *There is no shade or shelter from sun/winds. The playground is situated in an exposed elevated area.*
- *Site is in unsafe condition for play due to its adjacency to the delivery driveway: It is not enclosed from it; there is, an open vehicular leaf gate that is always kept open. Child supervisors need to be always vigilant in case there are any delivery trucks coming during the time children are playing.*
- *No ADA compliance path connection between the play equipment and seating area (would need an accessible ramp and concrete pad for a wheelchair next to the benches).*

2022 Playground Study Report

Prepared for the City of Salem Public Schools, in Massachusetts

2. VISUAL SURFACING REVIEW:

SURFACING TYPE(S):

| | | | | | |
|---|------------------------------|--------------------------------|-------------------------------|--------------------------------|--------------------------------------|
| <input checked="" type="checkbox"/> EWF | <input type="checkbox"/> PIP | <input type="checkbox"/> TILES | <input type="checkbox"/> SAND | <input type="checkbox"/> GRASS | <input type="checkbox"/> OTHER _____ |
|---|------------------------------|--------------------------------|-------------------------------|--------------------------------|--------------------------------------|

| | | | |
|-------------------------------|-------------------------------|--|------------------------------------|
| <input type="checkbox"/> POOR | <input type="checkbox"/> FAIR | <input checked="" type="checkbox"/> GOOD | <input type="checkbox"/> COMPLIANT |
|-------------------------------|-------------------------------|--|------------------------------------|

- *Wear mats should be placed at the end/bottom of the slides. Top off surfacing, as it gets 'kicked out'*
- *EWF- needs edging and a defined apron entrance.*

3. COMPONENT STRUCTURE REVIEW:

| | | | |
|--|-------------------------------|-------------------------------|------------------------------------|
| <input checked="" type="checkbox"/> POOR | <input type="checkbox"/> FAIR | <input type="checkbox"/> GOOD | <input type="checkbox"/> COMPLIANT |
|--|-------------------------------|-------------------------------|------------------------------------|

- **HAZARD 1 Safety Concern:** *The purple slide (broken) needs to be 'boarded up' with plywood attached to hood (at the top) until a replacement is installed.*
- *Rocker step – rubber is cracked; stairs are cracked with exposed metal.*
- *Play structure is outdated and in need of replacement, repair, and maintenance. The placement/layout of play equipment is very close to the road.*

Play Equipment Inventory:

- *(1) Single slide and (1) Spiral slide*
- *(5) Step ladders and (1) Curved ladder*
- *(1) Vertical climber and (3) Horizontal bars (only one is ADA compliant)*
- *(1) Transfer station*
- *(1) Balance swing*
- *(1) Zip line*
- *(1) Play panel*

2022 Playground Study Report

Prepared for the City of Salem Public Schools, in Massachusetts

4. FREE STANDING EQUIPMENT (INCLUDING SWINGS):

| | | | |
|-------------------------------|-------------------------------|--|---|
| <input type="checkbox"/> POOR | <input type="checkbox"/> FAIR | <input checked="" type="checkbox"/> GOOD | <input checked="" type="checkbox"/> COMPLIANT |
|-------------------------------|-------------------------------|--|---|

- *Climber is in excellent condition. Feedback from teachers and aides is that it is not used.*

5. SITE AMENITIES:

| | | | |
|--|-------------------------------|-------------------------------|------------------------------------|
| <input checked="" type="checkbox"/> POOR | <input type="checkbox"/> FAIR | <input type="checkbox"/> GOOD | <input type="checkbox"/> COMPLIANT |
|--|-------------------------------|-------------------------------|------------------------------------|

- *(4) Benches - are chipping off exposing rusted metal*
- *Leaf gate- needs a stop bollard. (See photos)*
- *Fence/other type of enclosure- needs to be added for safety.*

6. SUMMARY | RECOMMENDATIONS

OVERALL CONDITION OF PLAYGROUND:

| | | | |
|-------------------------------|--|-------------------------------|------------------------------------|
| <input type="checkbox"/> POOR | <input checked="" type="checkbox"/> FAIR | <input type="checkbox"/> GOOD | <input type="checkbox"/> COMPLIANT |
|-------------------------------|--|-------------------------------|------------------------------------|

- *The slide needs to be replaced ASAP.*
- *Climber- needs paint touch up.*
- *Transfer module and stairs should be replaced ASAP and at the same time due to continual play.*
- *At the time of inspection, recess was in session. It was evident that there was not enough equipment for the number of users.*
- *Consider an embankment slide (or two) at the berm. It was noted that the children are running up and down the slope; an embankment slide may lessen this.*
- *Consider adding some panels either on or near the equipment. Play panels do not need use zones and will add a much-needed sensory play experience.*
- *Consider a 'drop shot' on the asphalt for a play experience using the upper body. The children do not seem to utilize the asphalt.*

2022 Playground Study Report

Prepared for the City of Salem Public Schools, in Massachusetts

7. PLAYGROUND PHOTOGRAPHS:

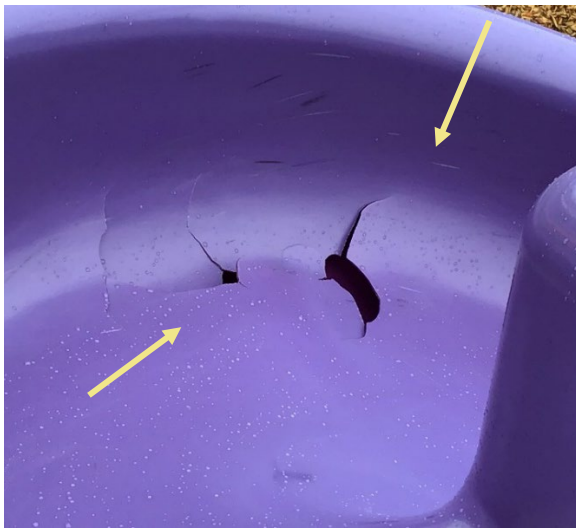

2022 Playground Study Report
Prepared for the City of Salem Public Schools, in Massachusetts



2022 Playground Study Report

Prepared for the City of Salem Public Schools, in Massachusetts

8. PLAYGROUND SITE PHOTOGRAPHS:



2022 Playground Study Report

Prepared for the City of Salem Public Schools, in Massachusetts



PLAYGROUND NAME:

**WITCHCRAFT HEIGHTS
ELEMENTARY SCHOOL
5-12 Y.O. PLAYGROUND**

PLAYGROUND ADDRESS:

**1 Frederick St, Salem, MA
01970**

DATE OF SITE VISIT:

2 May 2022

MANUFACTURER/S:

**PlayWorld
("Playmakers") and Little
Tikes**

AGE APPROPRIATE:

| | | | |
|----------------------------------|--|-----------------------------------|----------------------------------|
| <input type="checkbox"/> 2-5 YRS | <input checked="" type="checkbox"/> 5-12 YRS | <input type="checkbox"/> 2-12 YRS | <input type="checkbox"/> 13+ YRS |
|----------------------------------|--|-----------------------------------|----------------------------------|

1. GENERAL SITE CONDITIONS AND APPROACH:

| | | | |
|--|-------------------------------|-------------------------------|------------------------------------|
| <input checked="" type="checkbox"/> POOR | <input type="checkbox"/> FAIR | <input type="checkbox"/> GOOD | <input type="checkbox"/> COMPLIANT |
|--|-------------------------------|-------------------------------|------------------------------------|

- *The entrance is good as it is paved and visible – however, it is not ADA compliant (the asphalt walkway is **11.35%** at its steepest point and has a cross pitch of **2.5%** (**ADA compliant ramps with handrails have a maximum slope of 8.33% and a maximum cross pitch of 2%**)).*
- *There are cracks on this asphalt pavement that can become tripping hazards.*
- *The turnaround with painted games has a curb cut for ADA access.*
- *The fence enclosing the playground is in good condition, except for the galvanized chain link fence abutting the private property, downwards.*

2022 Playground Study Report

Prepared for the City of Salem Public Schools, in Massachusetts

- Overall, the site and playground are in poor condition, due to poor drainage and outdated play structures. We assume there is an impermeable subsurface due to the wetland conditions forming to the right of the sloped walkway. It is important to address this because it could lead to other site problems and promote population of mosquitos developing, due to standing water.

2. VISUAL SURFACING REVIEW:

SURFACING TYPE(S):

| | | | | | |
|---|------------------------------|--------------------------------|-------------------------------|--------------------------------|--------------------------------------|
| <input checked="" type="checkbox"/> EWF | <input type="checkbox"/> PIP | <input type="checkbox"/> TILES | <input type="checkbox"/> SAND | <input type="checkbox"/> GRASS | <input type="checkbox"/> OTHER _____ |
|---|------------------------------|--------------------------------|-------------------------------|--------------------------------|--------------------------------------|

| | | | |
|-------------------------------|--|-------------------------------|------------------------------------|
| <input type="checkbox"/> POOR | <input checked="" type="checkbox"/> FAIR | <input type="checkbox"/> GOOD | <input type="checkbox"/> COMPLIANT |
|-------------------------------|--|-------------------------------|------------------------------------|

- The geotextile filter fabric is visible, which indicates EWF was not raked in properly.
- EWF - needs edge repairing; plastic edging along the back and side of the playground has been removed or displaced to be able to open the maintenance (vehicular gates). This is a design problem that poses a potential hazard due to loose/missing bolts and other non-play equipment parts.

3. COMPONENT STRUCTURE REVIEW:

| | | | |
|-------------------------------|--|-------------------------------|------------------------------------|
| <input type="checkbox"/> POOR | <input checked="" type="checkbox"/> FAIR | <input type="checkbox"/> GOOD | <input type="checkbox"/> COMPLIANT |
|-------------------------------|--|-------------------------------|------------------------------------|

- **HAZARD 1 Safety Concern:** The single slide is broken at chute and hood; needs to be removed due to potential hazard 1. (See photos). Needs to be 'boarded up' with plywood attached to hood (at the top) until a replacement is installed.
- Chain ladder hardware is loose and missing bolts, attachment to the deck platform is failing and chain coat is cracked.
- A second (double) slide has two holes.
- Several welds are beginning to rust.
- Spiral slide is missing handhold which forces child into a sitting position.
- The bridge has an opening.

2022 Playground Study Report

Prepared for the City of Salem Public Schools, in Massachusetts

- *Hex deck may be missing bolts.*
- *Hardware is backing out in a variety of places.*
- *Parts of the Clatter bridge have been replaced but they should replace the remaining pieces (coating has worn off and there is peeling).*
- *FYI only: poor design on placement of the play panel with a window and stair in very close proximity.*
- *Paint on post is peeling.*
- *Forced equipment to make a play structure link - but it does not.*
- *Transfer bottom is peeling and needs to be replaced also due to cracks.*
- *Stairs and net climber are overlapping in use zones (9' apart; 12' is required).*

Play Equipment Inventory:

- *(1) Balance swing*
- *(2) Overhead horizontal ladder and (2) Overhead bars*
- *(1) Vertical climber with panels*
- *(1) Corkscrew climber*
- *(2) Diagonal climbers with (1) Step ladder*
- *(1) Balance beam*
- *(1) Horizontal Overhead Rings – Note: missing (1) ring*
- *(2) Zip lines*
- *(2) Play panels*
- *(5) Step ladders*

2022 Playground Study Report

Prepared for the City of Salem Public Schools, in Massachusetts

- (1) Mini stairs (brown)
- (1) Spiral slide; (1) Double slide (1) Single slide
- (1) Bridge
- (1) Transfer station

4. FREE STANDING EQUIPMENT (INCLUDING SWINGS):

| | | | |
|--|-------------------------------|-------------------------------|------------------------------------|
| <input checked="" type="checkbox"/> POOR | <input type="checkbox"/> FAIR | <input type="checkbox"/> GOOD | <input type="checkbox"/> COMPLIANT |
|--|-------------------------------|-------------------------------|------------------------------------|

- Net climber - rope is frayed throughout and needs to be replaced. Net climber is 9' from stairs (**12' is the required use zone**).
- Three of the footings are exposed.

5. SITE AMENITIES:

| | | | |
|-------------------------------|--|-------------------------------|------------------------------------|
| <input type="checkbox"/> POOR | <input checked="" type="checkbox"/> FAIR | <input type="checkbox"/> GOOD | <input type="checkbox"/> COMPLIANT |
|-------------------------------|--|-------------------------------|------------------------------------|

- Fence- back chain link fence is rusted
- Pedestrian Gates- needs to be added
- Drain manholes need cleaning and maintenance

6. SUMMARY | RECOMMENDATIONS

OVERALL CONDITION OF PLAYGROUND:

| | | | |
|--|-------------------------------|-------------------------------|------------------------------------|
| <input checked="" type="checkbox"/> POOR | <input type="checkbox"/> FAIR | <input type="checkbox"/> GOOD | <input type="checkbox"/> COMPLIANT |
|--|-------------------------------|-------------------------------|------------------------------------|

- Component Structure:
- Track rides need to be connected – they are not linked to continuous play. The fitness portion needs to be removed. Note: the play structure is made of play equipment and fitness equipment which does not link continuous play.
- Consider decks on both sides of the track rides.
- Replace or repair the bridge.

2022 Playground Study Report

Prepared for the City of Salem Public Schools, in Massachusetts

- *Missing ring on Overhead needs replacement.*
- *The transfer deck needs to be replaced due to peeled PVC and metal deteriorating.*
- *The grid bridge is rusting with open PVC and water is getting in.*
- *Free-standing Structure: the frayed rope needs to be replaced. Check with the manufacturer with regards to footings: verify that they should be 'exposed.'*
- *Surfacing and paving and other site amenities:*
- *The site at Witchcraft is sloped, thus EWF travels. EWF needs maintenance.*
- *Address the exposed filter fabric (needs to be cut)*
- *The ramp is +/- 10% @ the steepest section and should be addressed to meet ADA compliance and adjacent drainage issues.*
- *Chain link mesh fence needs tightening.*
- *Need to swap/cut projecting-out hardware on the fence to avoid eye protrusions.*
- *(1) Basketball court- needs asphalt crack repair and new paint*
- *2 basketball hoops- need new nets*

2022 Playground Study Report

Prepared for the City of Salem Public Schools, in Massachusetts

7. PLAYGROUND PHOTOGRAPHS:

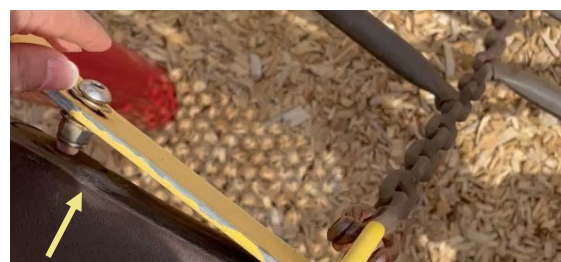

2022 Playground Study Report

Prepared for the City of Salem Public Schools, in Massachusetts

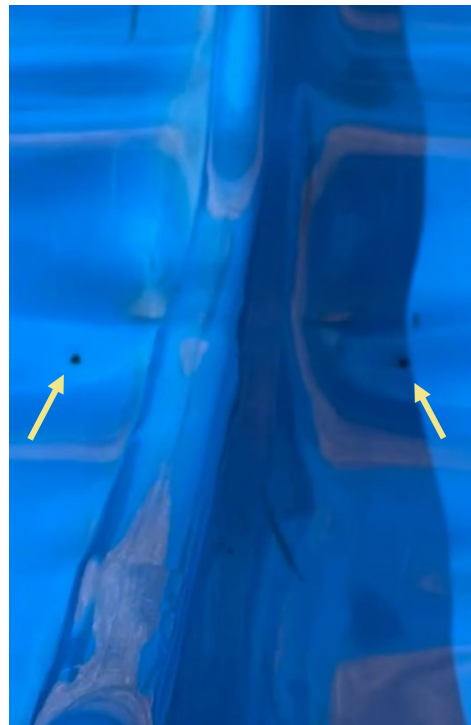

2022 Playground Study Report

Prepared for the City of Salem Public Schools, in Massachusetts



2022 Playground Study Report

Prepared for the City of Salem Public Schools, in Massachusetts

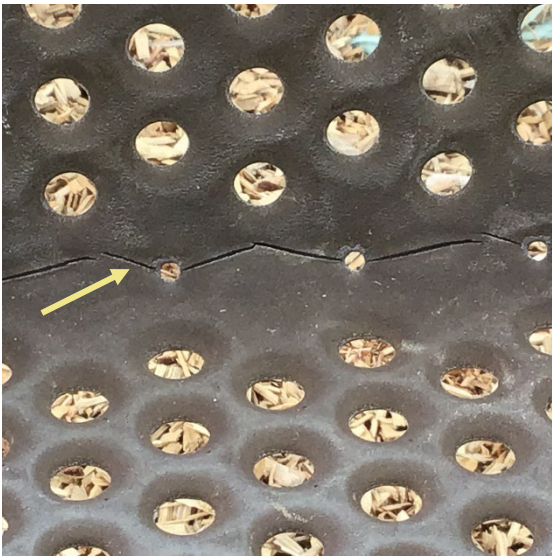

2022 Playground Study Report
Prepared for the City of Salem Public Schools, in Massachusetts

8. PLAYGROUND SITE PHOTOGRAPHS:



2022 Playground Study Report
Prepared for the City of Salem Public Schools, in Massachusetts



2022 Playground Study Report

Prepared for the City of Salem Public Schools, in Massachusetts

9. 2D LAYOUTS:

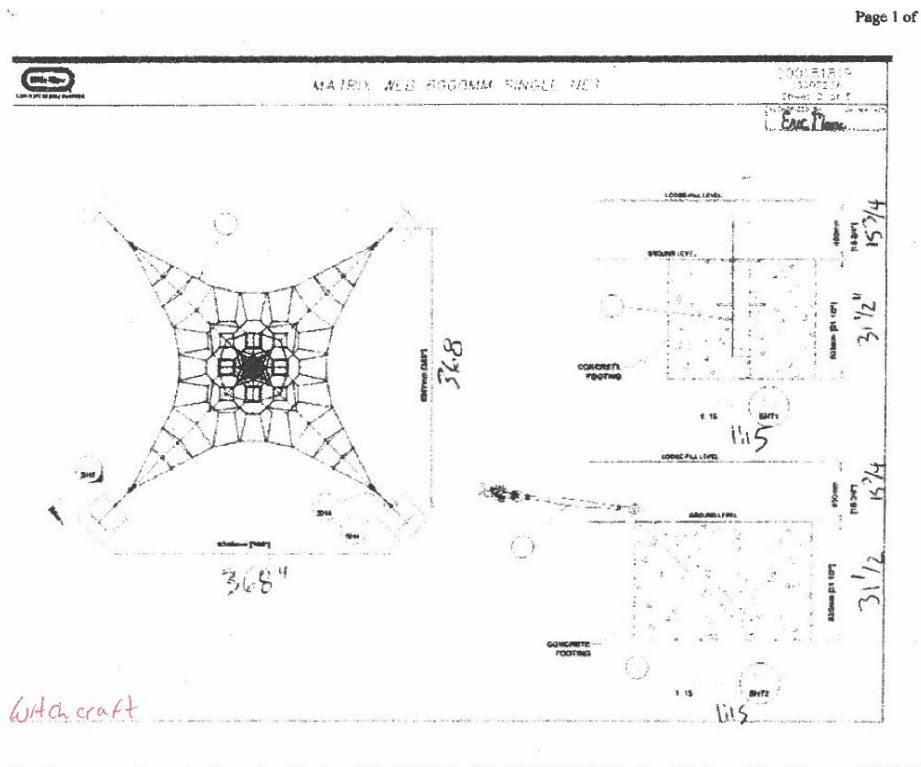
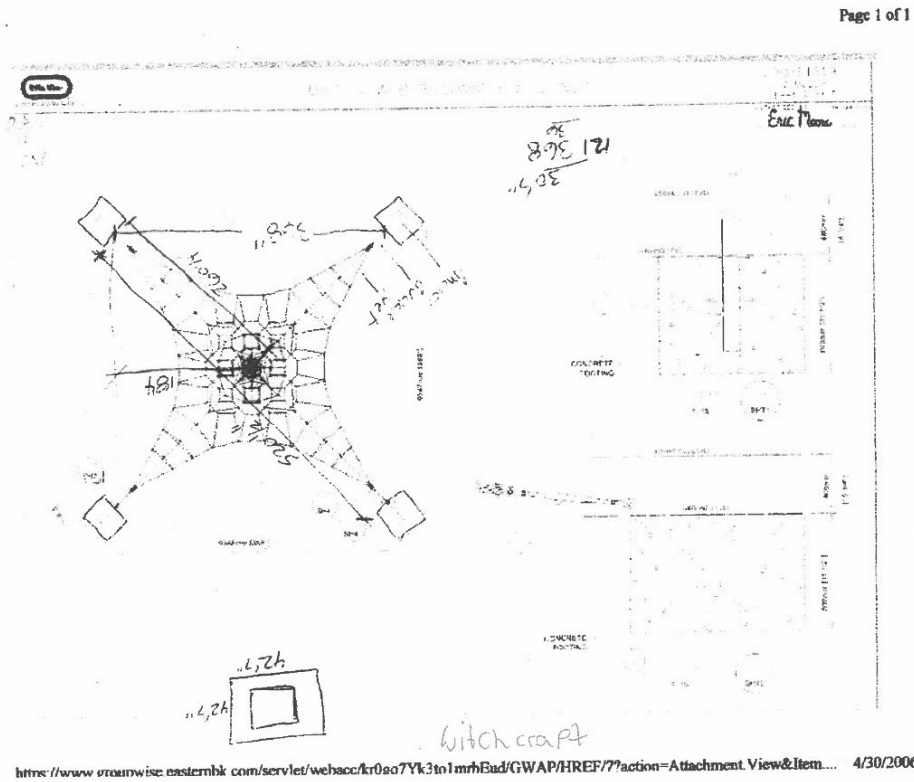

2022 Playground Study Report

Prepared for the City of Salem Public Schools, in Massachusetts

SUMMARY OF THE PLAYGROUND ASSESSMENT

| | | status grid | | | | | | | | | | | | |
|-----------------------------------|--------------------------------------|---------------------------------|-----------------|--|---|-----------------------|---------------------------|---|--------------------------------------|---------------------------------------|------------------|--|------------------------------------|---------------------------------|
| SCHOOL NAME | ADDRESS | HAZARD 1 Safety Concern at Site | USE ZONE HAZARD | LOOSE FILL SURFACE MAINTENANCE NEEDED (Weeds, Additional Fill) | UNITARY SURFACING MAINTENANCE NEEDED (Repair or Replace Surface Maintenance Needed (Weeds, Addtl Fill)) | HAZARDOUS LANDSCAPING | SAFETY LABELS AND SIGNAGE | PHYSICAL CONTROL BARRIER IN DISREPAIR (Bollards, Fence, etc.) | STRUCTURES W/ COMPROMISED EQUIPMENT* | SITE REVIEW REMOVAL OF EQUIPMENT ASAP | PERIMETER EDGING | SITE FURNISHINGS HAZARD REVIEW (Benches, Picnic Tables, Trash) | CONSIDER PARTIAL UNITARY SURFACING | CONSIDER FULL UNITARY SURFACING |
| Bates Elementary School 2-5 | 53 Liberty Hill Ave. Salem, MA 01970 | X | | | X | | X | | X | X | | | | X |
| Bates Elementary School 5-12 | 53 Liberty Hill Ave. Salem, MA 01970 | X | | X | | | X | | X | | | | X | |
| Salem Early Childhood School | 25 Memorial Dr. Salem, MA 01970 | X | X | | X | | X | | X | X | | | | X |
| Bentley Academy Innovation School | 25 Memorial Dr. Salem, MA 01970 | | | | X | | | | | | | | | |
| Saitonstall School 2-5 | 211 Lafayette St. Salem, MA 01970 | | | X | | | X | | X | | | X | | X |

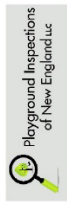

PLAYGROUND CONSULTANCY

LANDSCAPE ARCHITECTURE

2022 Playground Study Report

Prepared for the City of Salem Public Schools, in Massachusetts

status grid



PLAYGROUND CONSULTANCY

LANDSCAPE ARCHITECTURE

| SCHOOL NAME | ADDRESS | HAZARD 1 Safety Concern at Site | USE ZONE HAZARD | LOOSE FILL SURFACE MAINTENANCE NEEDED (Weeds, Additional Fill) | UNITARY SURFACING MAINTENANCE NEEDED (Repair or Replace) Surface Maintenance Needed (Weeds, Addtl Fill) | HAZARDOUS LANDSCAPING | SAFETY LABELS AND SIGNAGE | PHYSICAL CONTROL BARRIER IN DISREPAIR (Bollards, Fence, etc.) | STRUCTURES W/ COMPROMISED EQUIPMENT* | SITE REVIEW REMOVAL OF EQUIPMENT ASAP | PERIMETER EDGING | SITE FURNISHINGS HAZARD REVIEW (Benches, Picnic Tables, Trash) | CONSIDER PARTIAL UNITARY SURFACING | CONSIDER FULL UNITARY SURFACING |
|--------------------------------------|-----------------------------------|---------------------------------|-----------------|--|---|-----------------------|---------------------------|---|--------------------------------------|---------------------------------------|------------------|--|------------------------------------|---------------------------------|
| Saltonstall School 5-12 | 211 Lafayette St. Salem, MA 01970 | | | X | | | X | | | | | | | X |
| Horace Mann Laboratory School 2-5 | 79 Wilson St. Salem, MA 01970 | X | | X | | | X | | X | X | | | X | |
| Horace Mann Laboratory School 5-12 | 79 Wilson St. Salem, MA 01970 | X | | X | | X | X | | X | | | | | X |
| Witchcraft Heights Elementary School | 1 Frederick St. Salem, MA 01970 | X | X | X | | X | X | | X | X | X | | | X |

2022 Playground Study Report

Prepared for the City of Salem Public Schools, in Massachusetts

PLAY EQUIPMENT RATING BY SITE

PINE list based on equipment safety status and age appropriateness from highest to lowest maintenance needs is as follows:

(This list does not consider playground surfacing, only equipment)

1. *Witchcraft Heights Elementary School*
2. *Bates Elementary School (2-5 Y.O. Playground- due to broken and aged parts)*
3. *Horace Mann Laboratory School (5-12 Y.O. Playground- due to broken parts)*
4. *Salem Early Childhood Center (ADA metal swing on public playground)*
5. *Bates Elementary School (5-12 Y.O. Playground- due to broken parts)*
6. *Horace Mann Laboratory School (2-5 Y.O. Playground- based on age-appropriateness)*
7. *Saltonstall School (Kindergarten Playground- based on age-appropriateness)*
8. *Bentley Academy Innovation School*
9. *Saltonstall School (5-12 Y.O. Playground)*

Note: *Carlton Innovation School playground was not included as it has no equipment*

PINE list based on equipment with best play value:

1. *Saltonstall School (5-12 Y.O. Playground)*
2. *Bentley Academy Innovation School*
3. *Bates Elementary School (5-12 Y.O. Playground)*

CONCLUSION ON PLAYGROUND ASSESSMENTS

With the three best playgrounds not included in this review, the overall summary indicates fair to poor conditions of your playgrounds. A lack of attention to detail to your assets have rendered them into the condition they are today. The reason for their current condition is also due to a lack of understanding of their use, as it was observed and said

2022 Playground Study Report

Prepared for the City of Salem Public Schools, in Massachusetts

(per the online survey) that these playgrounds not exclusive to the schools' students. Given that your school playgrounds are used by thousands of children, their management must make a concerted effort to decide how to address the following:

- *Status of safety or lack there off*
- *Age appropriateness*
- *Lack of involvement with each school to take ownership and full maintenance responsibilities*
- *Accessible route of travel to meet ADA*
- *Evaluate how best to meet MAAB regulations*
- *Define and implement organization charts to address hazards*
- *Provide in-house inspections on a regular basis and keep documents on file*
- *Train supervises on their roles and responsibilities regarding playgrounds as most accidents are avoidable*
- *Have a list of manufacturer representatives for any assistance*
- *Plan on rehabilitation for the playgrounds that need it*
- *Show a good faith effort of a capital plan in writing for annual review as circumstances may change. For example, a school that now has preschool but did not years ago.*
- *Show of good faith effort and plans to retrofit or rehab old/non-compliant playgrounds*
- *Create ways to communicate efforts being made by the school to improve and maintain these playgrounds*
- *Review any set of possible new additions to school buildings and assess how this could affect the site of the playgrounds*
- *Review play value and keep parent, teachers, physical education teachers and special need therapist in mind as the new playground can benefit in outside therapy with better*

2022 Playground Study Report

Prepared for the City of Salem Public Schools, in Massachusetts

equipment and some of the school staff can consider the use of new playgrounds in their curriculum

- *Understand that no equipment is “dangerous” but rather “a challenge/ risk” for the child to embark. It is when that risk becomes a hazard, as is the case with many aspects of the play equipment, that it is unsafe for a child.*
- *Take full responsibility of ownership and not allow private funding (from only PTO or PTA) to decide the direction on the playground, but focus on the needs of the school and the playground users*
- *Choose better play value and quality of play equipment to open a larger/intense user base.*
- *Cater to current users: Is the play equipment too stimulating or is it under stimulating?*
- *Adapt to change: Will the play equipment be used for many generations? How can it be flexible or easily retrofit to change to new users?*
- *For optimal supervision and safety, keep the best site lines*
- *Avoid high maintenance components or with simple play value. (For example, plastic bubble panels or electronic play events that break easily/need maintenance).*
- *All Playground manufacturers must provide a “Maintenance Kit”. It is the Owners responsibility to store it in a safe place and document used of it so that parts can be replaced or updated.*

SUMMARY OF THE ONLINE SURVEY

Before commencing the onsite playground assessments, PINE and m3 Land Studio conducted an online survey to understand the schools’ users, needs, maintenance/repair protocol, concerns, and wishes. The following table and graphs provide a summary and comparison of these online survey results. Please refer to the Appendix, at the end of this report, for a copy of the online survey with anonymous responses.

2022 Playground Study Report

Prepared for the City of Salem Public Schools, in Massachusetts

QUANTITATIVE DATA RESULTS:

| SCHOOL | # PLAYGROUNDS | # RESPONSES | # STUDENTS | TREND IN # STUDENTS | DO ALL STUDENTS USE PG? | APPROPRIATE # PG SUPERVISORS? |
|---|---------------|-------------|------------|---------------------|-------------------------|-------------------------------|
| *Bates Elementary School | 2 | 0 | | | | |
| Salem Early Childhood Center | 1 | 1 | 150 | ↑ | Y | Y |
| Bentley Academy Innovation School | 1 | 3 | 350 | = | Y | Y |
| Saltonstall School | 2 | 2 | 400 | = | Y | N |
| Horace Mann Laboratory School | 2 | 9 | 300 | = | Y | N |
| Witchcraft Heights Elementary School | 1 | 2 | 500 | ↓ | N | N |
| ** Carlton Innovation School | 0 | 1 | 254 | ↑ | Y | Y |

Note: Non-responses have been left blanked. For instance, ***Bates Elementary School** only recorded the first question. No other answers were registered, so it was left in all summary tables. ****Carlton Innovation School** completed the survey but has no playground within its school premises, so the responses were left as they were and to inform Phase 3 of this report.

2022 Playground Study Report

Prepared for the City of Salem Public Schools, in Massachusetts

QUANTITATIVE DATA RESULTS:

| SCHOOL | SUFFICIENT PLAY EQUIPMENT FOR USER NEEDS? | AFTER SCHOOL USE | RANK AFTER SCHOOL USE: (L= LIGHT M= MODERATE H = HEAVY) | ARE THEY USED FOR NON-SCHOOL PROGRAMS? | HOW OFTEN MAINTAINED? (A N = AS NEEDED) | STD PROTOCOL FOR REPAIR? | PG SAFETY CONCERNS? |
|---|---|------------------|--|--|--|--------------------------|---------------------|
| *Bates Elementary School | | | | | | | |
| Salem Early Childhood Center | N | Y | L | N | N/A | N | N |
| Bentley Academy Innovation School | N | Y | M | Y | N/A | N | Y |
| Saltonstall School | Y | Y | H | Y | A N | N | Y |
| Horace Mann Laboratory School | N | Y | M | Y | N/A | Y | Y |
| Witchcraft Heights Elementary School | N | Y | L | Y | N/A | Y | Y |
| **Carlton Innovation School | N | Y | H | Y | N/A | N | Y |

2022 Playground Study Report

Prepared for the City of Salem Public Schools, in Massachusetts

QUALITATIVE DATA RESULTS (USE DURING SCHOOL HOURS):

| SCHOOL | HOW MANY STUDENTS ARE ON THE PG AT THE SAME TIME? | WHO SUPERVISES THE STUDENTS WHEN USING THE PG(S)? | ACCESSIBILITY QUESTION: |
|---|---|---|--|
| *Bates Elementary School | | | |
| Salem Early Childhood Center | 30 | Teachers, Aids, Admin Staff | |
| Bentley Academy Innovation School | 50-60 20-60 | Teachers, Aids, Admin Staff Recess coaches | |
| Saltonstall School | 30 (PG1) 100 (PG2) | Teachers, Aids, Admin Staff | |
| Horace Mann Laboratory School | 40-60 | Teachers, Aids, Admin Staff | |
| Witchcraft Heights Elementary School | 20-60 | Teachers, Aids, Admin Staff | Our playground is not accessible to students with mobility issues. |
| **Carlton Innovation School | 50-60 | | |

2022 Playground Study Report

Prepared for the City of Salem Public Schools, in Massachusetts

QUALITATIVE DATA RESULTS (PLAY EQUIPMENT):

| SCHOOL | WHICH ARE THE MOST USED/POPULAR PLAY EQUIPMENT? | WHICH ARE THE LEAST USED PLAY EQUIPMENT? |
|--|---|--|
| *Bates Elementary School | | |
| Salem Early Childhood Center | Swings, play vehicles and bikes | The water table and the spinner. |
| Bentley Academy Innovation School | Swings Swings, football, hammock, slide, ladder, surfboard | Balance beam, drums, wheel Shaded bench |
| Saltonstall School | Swing, spinner and various monkey bars. Gaga pit, basketball hoop, both playgrounds, blacktop really everything gets used! | Drums The Canopy that was built hasn't been used to its fullest potential |
| Horace Mann Laboratory School | Slides (8) Climbing (4) Monkey bars (3) Basketball courts (2) Playscape Pavement | Separate climbing structure Basketball zip line Hopscotch, four square Field Climbing Wall |

2022 Playground Study Report

Prepared for the City of Salem Public Schools, in Massachusetts

| SCHOOL | WHICH ARE THE MOST USED/POPULAR PLAY EQUIPMENT? | WHICH ARE THE LEAST USED PLAY EQUIPMENT? |
|---|---|--|
| Witchcraft Heights Elementary School | For older kids (G 3-5): spider web and monkey bars; Younger kids (G K-2): Slides and metal bridge that connects different slides Climbing Structure | Grades 3-5: Balance Beam; K-2: the metal equipment you stand and bounce on by the monkey bars Basketball hoops |
| **Carlton Innovation School | Slides, Structure, Spiral slides | Little balance beam |

2022 Playground Study Report

Prepared for the City of Salem Public Schools, in Massachusetts

QUALITATIVE DATA RESULTS (LIKES | DISLIKES ABOUT CURRENT PLAYGROUND):

| SCHOOL | WHAT ARE THE THINGS <u>YOU LIKE</u> THE <u>LEAST</u> ABOUT THE CURRENT PLAYGROUND(S)? | WHAT ARE THE THINGS <u>YOU LIKE</u> THE <u>MOST</u> ABOUT YOUR PLAYGROUND(S)? | WHAT ARE THE THINGS YOUR <u>STUDENTS LIKE</u> THE <u>MOST</u> ABOUT THE PLAYGROUND(S)? |
|--|--|---|--|
| *Bates Elementary School | | | |
| Salem Early Childhood Center | The water table and the spinner. There is no climbing structure or slides and no opportunity for students to build gross motor skills. | The track for the vehicles. | The track and vehicles and the swings. |
| Bentley Academy Innovation School | too small- wish it were wider. Buddy benches, not running on the pavement, not playing on the field, seats under the slide, broken ladder, four square, drums. Rope bridge- students fall through; side by the fence floods/takes a while to drain | Rubberized surface. No mulch-turf/rubber surface, the swing, the mural | The swings and the structure Monkey bars, hammock, swings, swinging circles The swing, the mural |

2022 Playground Study Report

Prepared for the City of Salem Public Schools, in Massachusetts

| SCHOOL | WHAT ARE THE THINGS <u>YOU LIKE THE LEAST</u> ABOUT THE CURRENT PLAYGROUND(S)? | WHAT ARE THE THINGS <u>YOU LIKE THE MOST</u> ABOUT YOUR PLAYGROUND(S)? | WHAT ARE THE THINGS YOUR <u>STUDENTS LIKE THE MOST</u> ABOUT THE PLAYGROUND(S)? |
|---|---|--|--|
| <p>Saltonstall School</p> | <p>There is only 1 swing, and it is designed for multiple people, student swing it to high and fast.</p> <p>I would love to see the city taking better care of our playgrounds, upkeep, trash collection, paint, other maintenance shouldn't fall on the shoulders of PTOs!</p> | <p>It is designed as a circuit and has many items for kids to use at the same time.</p> <p>I love that it is a gathering place for students and parents to connect. We could use more benches because so many people hang around after school!</p> | <p>Swing, spinner, slide, monkey bars.</p> <p>That people gather after school to play. There is always something to do and someone to play with.</p> |
| <p>Horace Mann Laboratory School</p> | <p>Wood chips, broken slide/equipment. Not enough space for nature/creative play. Front of school needs a gate. Too high, too close to access</p> | <p>Kids seem to enjoy both PGs; two different playgrounds to meet diverse needs. Quality of materials. Big Space Many ways to play and use</p> | <p>the slides (5) Monkey bars (4) jumping platform (3) climbing structures (2)</p> |

2022 Playground Study Report

Prepared for the City of Salem Public Schools, in Massachusetts

| SCHOOL | WHAT ARE THE THINGS <u>YOU</u> LIKE THE <u>LEAST</u> ABOUT THE CURRENT PLAYGROUND(S)? | WHAT ARE THE THINGS <u>YOU</u> LIKE THE <u>MOST</u> ABOUT YOUR PLAYGROUND(S)? | WHAT ARE THE THINGS YOUR <u>STUDENTS</u> LIKE THE <u>MOST</u> ABOUT THE PLAYGROUND(S)? |
|--|--|--|--|
| | <p>road, not enough space to run. Wrong school name on our structure. Not accessible to our entire student body. Not age appropriate or accessible to students with disabilities. It's far from school and too spread out. (Kids must vote on where they can play). Not big enough for the whole grade level to use.</p> | <p>gross motor skills. Age appropriate, multiple choices. Two of different sizes/ability levels. Mostly fenced in for safety. It has multiple ways to get up and down. Bright colors, sturdy</p> | |
| <p>Witchcraft Heights Elementary School</p> | <p>The playground is very far from the school and once you get to it, it is up a high hill so inaccessible to many and has a mulch groundcover.</p> | <p>My children love the equipment they can climb on and do enjoy playing there. It's a fun space for many kids, but not</p> | <p>My own children love climbing equipment.</p> |

2022 Playground Study Report

Prepared for the City of Salem Public Schools, in Massachusetts

| SCHOOL | WHAT ARE THE THINGS <u>YOU</u> LIKE THE <u>LEAST</u> ABOUT THE CURRENT PLAYGROUND(S)? | WHAT ARE THE THINGS <u>YOU</u> LIKE THE <u>MOST</u> ABOUT YOUR PLAYGROUND(S)? | WHAT ARE THE THINGS YOUR <u>STUDENTS</u> LIKE THE <u>MOST</u> ABOUT THE PLAYGROUND(S)? |
|-----------------------------|---|---|--|
| | <p>The spider web (which the kids love), is dangerous and difficult to supervise. Much of the equipment is outdated.</p> <p>Alternating weeks for grades not accessible to all. Up on a hill. Spiderweb is dangerous.</p> | <p>an inclusive one.</p> <p>Fenced in for safety. It is connected to the basketball court for other activities but still in proximity</p> | |
| **Carlton Innovation School | Off School Property, the curb is dangerous, dog poop, open gate, mulch is not soft enough nor good for the playground, more accessible for all students. | Lots of room, Field, Basketball court, multiple options for all students. | Lots of room, field, basketball court, multiple options for all students. Structures. |

2022 Playground Study Report

Prepared for the City of Salem Public Schools, in Massachusetts

QUALITATIVE DATA RESULTS (MAINTENANCE):

| SCHOOL | WHO MAINTAINS THE PLAYGROUND(S)? | WHO IS NOTIFIED OF A BROKEN PLAYGROUND PIECE THE MOMENT IT IS NOTICED? |
|--|---|--|
| *Bates Elementary School | | |
| Salem Early Childhood Center | Salem Public Schools | Principal and then the custodian |
| Bentley Academy Innovation School | Maintenance/Custodial Staff PTA (trash pickup) | Maintenance staff Principal |
| Saltonstall School | School custodial staff/PTO supports funding. Right now, PTO and custodians. We need so much help!! Our playground is used heavily by students and neighborhood kids. There needs to be better maintenance, trash collection. PTO has tried to maintain the painted games, but it is hard to keep up! | Principal PTO/School Admin |

2022 Playground Study Report

Prepared for the City of Salem Public Schools, in Massachusetts

| SCHOOL | WHO MAINTAINS THE PLAYGROUND(S)? | WHO IS NOTIFIED OF A BROKEN PLAYGROUND PIECE THE MOMENT IT IS NOTICED? |
|---|---|--|
| Horace Mann Laboratory School | Buildings and grounds dept Salem Public Schools Building Custodial Staff Facilities | Principal Custodian Building Custodial Staff |
| Witchcraft Heights Elementary School | The Buildings and Grounds employed by the Salem Public Schools District. City of Salem, PTO/ Families | There is a citywide app (called SeeClickFix (?)) that you can report on. Notifications also go to the school Principal and or the Superintendent's office Principal |
| **Carlton Innovation School | City of Salem and Parents | "See Click Fix" website |

Note: Most people do not know who maintains their playgrounds or who to report things to. There is no actual playground reporting system that the schools are aware of.

2022 Playground Study Report

Prepared for the City of Salem Public Schools, in Massachusetts

QUALITATIVE DATA RESULTS (SAFETY CONCERNS):

| SCHOOL | WHAT PG SAFETY CONCERNS DO YOU HAVE? |
|---|--|
| *Bates Elementary | |
| Salem Early CC | (No response was recorded) |
| Bentley Academy Innovation School | <p>The surfboard.</p> <p>The playground is breaking. The balance beam hurts students.</p> <p>Rope bridge, play structure when it's wet.</p> |
| Saltonstall School | <p>The upper (kindergarten) playground has areas that are too high off the ground for the little kids, it is a hazard if they fall. The concrete around the upper playground is all heaved and is a constant trip hazard.</p> |
| Horace Mann Laboratory School | <p>The broken slide - not sure to what extent it has been adequately fixed.</p> <p>Cars, it's so spread out it's hard to staff</p> <p>Slide, sliding bar; Not large enough for all the kids on it</p> <p>The small playground at HMLS is located on the side of the main entrance.</p> |
| Witchcraft Heights Elementary School | <p>The spider web, though a student favorite, is difficult for staff to supervise, and kids can get really high. Gliding equipment has had problems that took over a year to repair.</p> |
| *Carlton Innovation School | <p>Mulch, Height of some of the equipment, Curb, Accessibility</p> |

2022 Playground Study Report

Prepared for the City of Salem Public Schools, in Massachusetts

QUALITATIVE DATA RESULTS (FUTURE PLAYGROUND):

| SCHOOL | IF MONEY WAS NOT A LIMITING FACTOR, HOW WOULD YOU LIKE THE NEW SCHOOL PG(S) TO BE? | WHICH KIND OF PLAY ELEMENTS WOULD YOU LIKE THE PLAYGROUND(S) TO HAVE? |
|-------------------------------------|--|---|
| *Bates Elementary School | | |
| Salem Early Childhood Center | <p>First the playground would be inclusive and adaptive to meet the needs of all students.</p> <p>The playground would have a "centers and zones" concept. It would have activity centers and zones to help kids enjoy opportunities to explore, test their physical skills and abilities, and build strength and coordination.</p> <p>It would have a climbing structure with multiple opportunities for students to build on their motor skills and gain physical confidence. In the structure there would also be a place for students to use their imagination - like create an ice cream stand or a house or a lookout tower etc. or a ship. It would include a variety of slides and walking areas and ramps.</p> <p>It would have lots of "loose parts" like life size blocks, building activities, giant trucks, and games. Buckets, pails, and shovels to be in a sand area. It</p> | |

2022 Playground Study Report

Prepared for the City of Salem Public Schools, in Massachusetts

| SCHOOL | IF MONEY WAS NOT A LIMITING FACTOR, HOW WOULD YOU LIKE THE NEW SCHOOL PG(S) TO BE? | WHICH KIND OF PLAY ELEMENTS WOULD YOU LIKE THE PLAYGROUND(S) TO HAVE? |
|--|---|---|
| | would have ample storage for the parts as well. Places to store outdoor bubbles, chalk, paint, and science activities | |
| Bentley Academy Innovation School | Another one for the younger kids. Tubes, more hammocks, pool/waterslide, football field, basketball court, fences, trampoline, SWINGS, baseball field, four squares, zipline, hockey rink, obstacle course, garden, Legos, climbing wall. At least 4-6 swings, more equipment, defined space for activities, 2nd playground, places to sit down, sensory areas, more shade. | Equipment for smaller students 4-6 swings, sensory areas |
| Saltonstall School | Built-in slide as a part of the hill, more multiuse pieces like small stages that can be for imaginative play. I would love to see consistent maintenance, better use of the canopy, more benches, a company to come in a repaint games on the surfaces every year, fix the heaving concrete, provide more balls/outside game equipment. The | More swings or no swings, one or the other. More balls, someone to come paint/maintain the surface games. More swings! Some moveable nets for soccer, etc. |

2022 Playground Study Report

Prepared for the City of Salem Public Schools, in Massachusetts

| SCHOOL | IF MONEY WAS NOT A LIMITING FACTOR, HOW WOULD YOU LIKE THE NEW SCHOOL PG(S) TO BE? | WHICH KIND OF PLAY ELEMENTS WOULD YOU LIKE THE PLAYGROUND(S) TO HAVE? |
|--------------------------------------|---|---|
| | custodians could use a shed for their exterior snow cleanup equipment! | |
| Horace Mann Laboratory School | <p>The larger playground in playground could use a full upgrade - more equipment, rubber surface, repainted Building Custodial Staff</p> <p>Include diverse types of activities (ex. monkey bars, moving steps, climbing ropes). Appropriate for all age groups, many opportunities to play on the equipment but also room for running and playground games.</p> <p>Spread out more with more places for students to play and more options. Our only slide for 1-5 is very steep.</p> <p>I would like it to be accessible, add swing sets, a bouldering wall, and any other fun obstacles.</p> <p>Multiple sizes of equipment to invite students of all sizes and abilities to enjoy the playground.</p> <p>Big and have no wood chips. Completely reconfigured. Climbing wall, larger structure.</p> | <p>More structures</p> <p>Nature incorporated. Natural materials</p> <p>Swing set, slide, jungle gym, chin-up bars, trapeze rings, playhouses, mazes.</p> <p>Slides, variety of monkey bars, low zip lines, tunnels, lily pads, things to bounce on.</p> <p>Swings.</p> <p>Rock/bouldering wall, swing sets.</p> <p>Various levels and monkey bars.</p> <p>More accessible for all.</p> |

2022 Playground Study Report

Prepared for the City of Salem Public Schools, in Massachusetts

| SCHOOL | IF MONEY WAS NOT A LIMITING FACTOR, HOW WOULD YOU LIKE THE NEW SCHOOL PG(S) TO BE? | WHICH KIND OF PLAY ELEMENTS WOULD YOU LIKE THE PLAYGROUND(S) TO HAVE? |
|---|--|---|
| | | Climbing wall, more activities to engage students, larger |
| Witchcraft Heights Elementary School | <p>Because WHES is the largest elementary school, we need more than one playground. A playground dedicated to younger students (K-2) and then another one for older students (3-5) would be ideal - as it stands now, there is not enough space on the playground to accommodate all the students sharing recess. Both playgrounds should be inclusive places - accessible to students in wheelchairs or with other mobility issues, as well as inclusive for children with sensory issues.</p> <p>Accessible to all i.e., wheelchair equipment. Moved down from the hill.</p> | <p>Really creative ones! Spaces that allow kids with all different abilities to play together (not separately in the same space).</p> <p>Swings for all. Soft ground. Balance structures bright musical equipment climbing. Slides.</p> |
| **Carlton Innovation School | <p>Make March Street Playground part of the school. Enclose the park. Accessible park with swings, Soccer Nets, Slides, Bridge, Smaller structure for younger</p> | <p>Monkey bars, slides, swings, structure, chairs you spin, playhouse.</p> |

2022 Playground Study Report

Prepared for the City of Salem Public Schools, in Massachusetts

| SCHOOL | IF MONEY WAS NOT A LIMITING FACTOR, HOW WOULD YOU LIKE THE NEW SCHOOL PG(S) TO BE? | WHICH KIND OF PLAY ELEMENTS WOULD YOU LIKE THE PLAYGROUND(S) TO HAVE? |
|---------------|---|--|
| | kids and larger one for bigger kids, nice padding (no mulch), No slide covering, taller fence near the bypass road, replace picnic tables, water filling station - Keep all 3 elements of the park - field, court and play structures | |

PHASE 2:

PLAYGROUND MAINTENANCE + MANAGEMENT



"Playground safety is no accident. What you do everyday matters more than what you do once in a while" – Anonymous.

2022 Playground Study Report

Prepared for the City of Salem Public Schools, in Massachusetts

INTRODUCTION

From the online survey responses, we can summarize the schools' maintenance concerns as follows:

- *The worst ranked play equipment coincidentally is in the school with the highest student body (Witchcraft, has 500 students and one playground).*

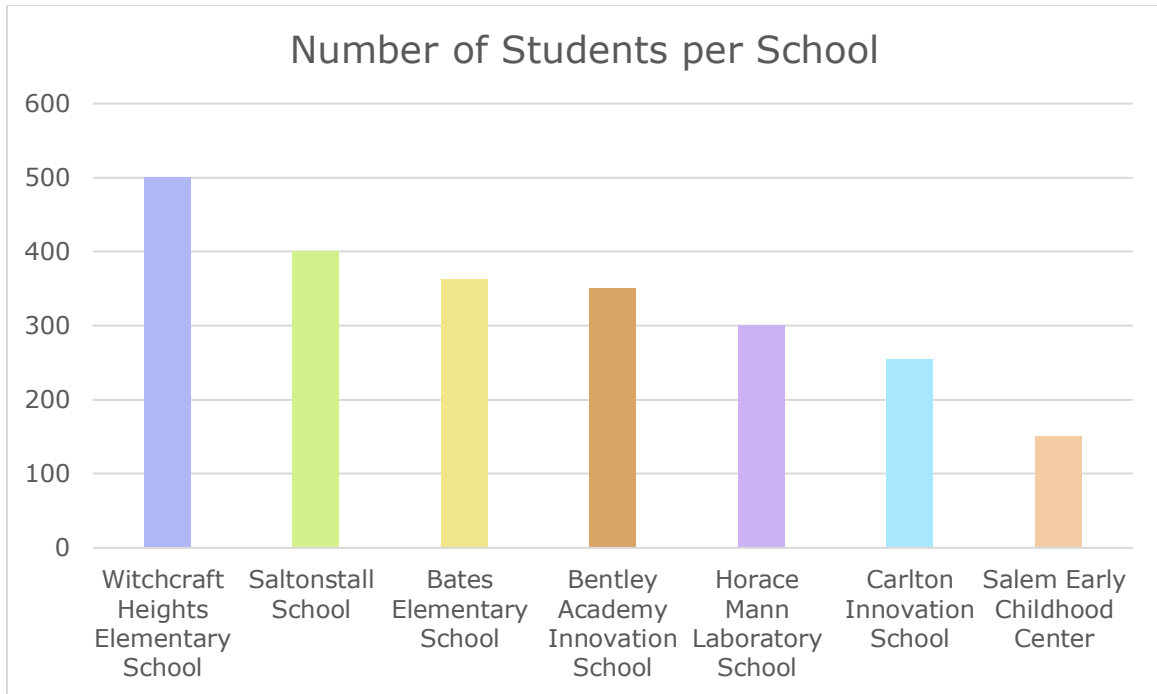

- *In general, the maximum number of students at any given time in a school playground is approximately 60.*
- *More than half of the schools don't think that the current amount of play equipment is sufficient based on the number of students currently attending the school.*
- *All school playgrounds are also used after school by students, other non-school programs, and community members.*
- *Most of the playgrounds used after school are used moderately to heavily, as shown below:*

2022 Playground Study Report

Prepared for the City of Salem Public Schools, in Massachusetts

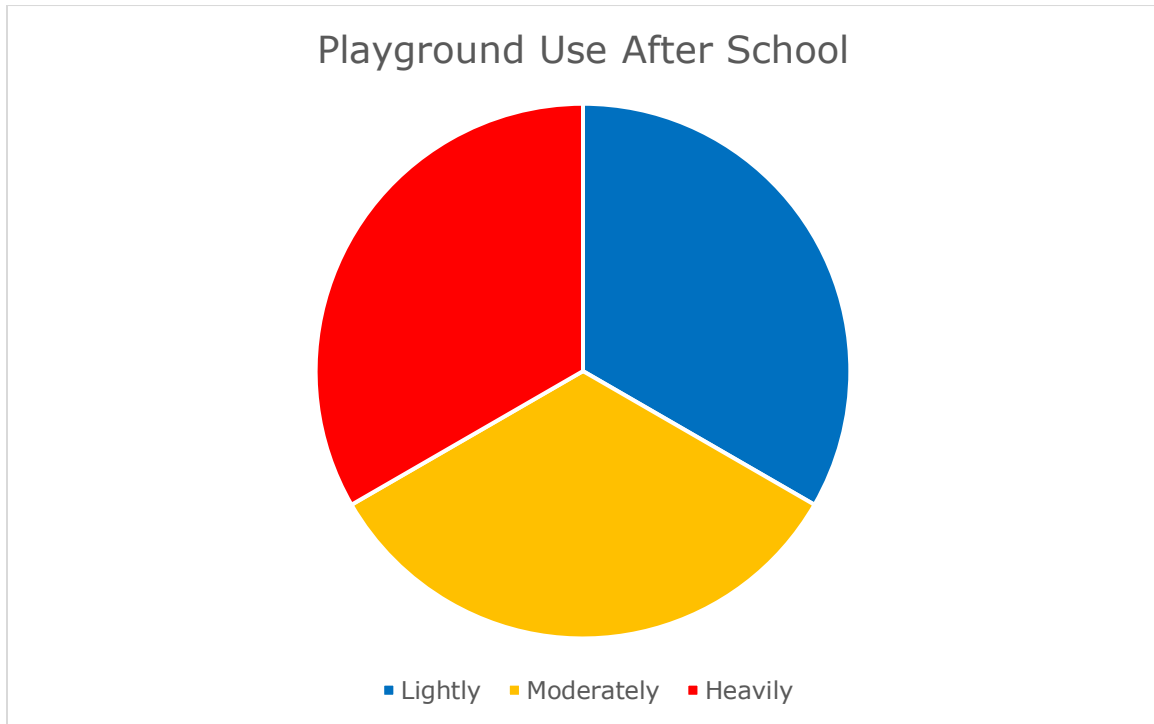

- *Most schools don't know of their maintenance protocols i.e., 'how often' and 'how' their playgrounds are/should be maintained, or what are/should be the standard protocols for repair/s.*
- *Most of the safety playground concerns raised are related to repairs: broken slides/equipment, pavement, and inaccessible play surfacing (EWF).*

This section of the report addresses 'Playground Maintenance and Management Protocols' for all public school playgrounds within the City of Salem. Although the protocols are based on ASTM and CPSC Safety Standards, PINE and M3 Land Studio have developed Best Management Practices specific for the Salem Public School Playgrounds.

It is important to note that the success of the maintenance and management of the playground facilities will depend on the Owner's ability to implement (employ protocols) and keep these protocols consistent and current.

Most accidents do not need to happen. Owners must understand there are multiple aspects of a playground that must be considered when plans are made. Gone are the days of parents raising money and installing what they want with no consideration of the long-term effects financially for material and labor to maintain. Parent participation is important,

2022 Playground Study Report

Prepared for the City of Salem Public Schools, in Massachusetts

but just like playgrounds, there are one of many aspects of involvement that need to be weighed in, to develop a successful and safe playground.

In addition to the above considerations, The USA is a litigious society. During PINE's years in this industry, they have been retained by municipalities, and law firms to try to avoid court cases and to settle them out of court with regards to playground accidents. In most instances, the Owner is at fault. Breaking arms and wrists are part of the risks of having and operating a playground, but when the risk becomes a hazard, and a hazard is not addressed in a timely fashion, this is when lawsuits arise. True fault is easily identified. Some of the accidents manifest into lifetime mental and physical effects.

Hazards and Risks

A hazard is a danger that cannot be foreseen. A risk involves choice, including a level of challenge in relation to the user.

The risk threshold is not entirely hard to differentiate as no two children are the same. For example, a track ride or glider in general is usable by physical size with normal strength, by children ages 8+. This does not mean an active five-year-old cannot complete the play experience. It also does not mean an 11-year-old can complete the activity. Children's past experiences usually dictate their willingness to try new challenges. Past experiences vary internally with each individual. The best we can do to reduce accidents is to take "reasonable precautions" when maintaining equipment. Children do not have a history of risk, thus as they grow, they learn and develop their risk tolerance. But it must first be experienced.

To fix existing playground equipment and surfacing is always a struggle with tight budgets. A more comprehensive maintenance plan should be in place prior to new equipment being installed; many times, this is not done, which means owners are inevitably going to be reactive as opposed to proactive.

2022 Playground Study Report

Prepared for the City of Salem Public Schools, in Massachusetts

INCORPORATING POLICY OF BEST PRACTICE FOR SCHOOL PLAYGROUND MAINTENANCE

No two playgrounds are the same. Nonetheless, the ability to report the facts of a playground's status is the same. Your playground is an asset to your school and must have records of past and present inspections. Assets take on different formats and your playground must be one of the assets reviewed for safety on a regular basis. Whether a playground was installed at the time that the school was built, or evolved and added afterwards, it indicates the owner's willingness to accept equipment and they must maintain it. If this cannot be done, then any process to add additional equipment should be stopped. School administration should set forth a policy that encompasses the ownership and maintenance of the playground equipment and in turn, each school sets the process based on the existing staff and playground users. Chronological record keeping is necessary and all information regarding the playground should remain at the school or at the Owner's property. It should be currently updated and maintained.

Outlining a Policy

The attached outline should be the baseline to maintain a playground. We have identified examples of key staff and processes that should be involved to assist with the outline policy and proper playground management:

Key Staff:

- *School Administrators (Principal/s)*
- *School Nurse*
- *School Facility Manager*
- *Custodian*
- *Playground Supervisors*
- *Office, facility manager, and custodian*

2022 Playground Study Report

Prepared for the City of Salem Public Schools, in Massachusetts

Documentation + Record to Maintain

- *Current Copy of Owners Playground Safety Program (to be developed by Owner)*
- *Current Copy of Industry Guidelines (CPSC Guidelines)*
 - *Pine will provide copies of CPSC guidelines and a general overview*
- *Documentation of 'Staff Trainings'*
- *Copy of notes during any meetings held regarding each playground*
- *Playground Site Information files – kept by location*

Forms + Checklists + Accident Report

The following attachments are standard forms developed by the 'International Playground Safety Institute'. We recommend incorporating these forms as the basis for a standard of care for playground maintenance and management:

- *Site History Checklist*
- *High Frequency Inspection Form*
- *Low Frequency Playground Matrix Inspection (short form)*
- *Accident Incident Form*

Note: In addition to internal record keeping and maintenance, an inspection of playgrounds by a Third party Certified Playground Safety Inspector is recommended on an annual or bi-annual basis.

Playground Site History Checklist

Site Name: _____ Date Eqpt Installed: _____

Date Checklist Completed: _____ Checklist Completed By: _____

| Item on File | | Checklist Items |
|--------------|----|---|
| YES | NO | |
| | | 1. Manufacturer's information – address, contact, phone, e-mail |
| | | 2. Insurance certificate (including product liability limits) |
| | | 3. Inspection, maintenance, and repair instructions |
| | | 4. Itemized lists of play components and parts |
| | | 5. Manufacturer's installation drawings and instructions |
| | | 6. Compliance letters: |
| | | a. Equipment compliance (w/ ASTM F1487, CPSC Handbook) |
| | | b. Installation compliance (w/ ASTM F1487, CPSC Handbook) |
| | | c. Surfacing compliance (w/ ASTM F1292, ASTM F 1951) |
| | | 7. Specifications and bid documents (equipment and surfacing) |
| | | 8. PO's, contracts, award documents |
| | | 9. Site plans and drawings |
| | | 10. Playground policy statement |
| | | 11. Staff training documentation |
| | | 12. Initial play area safety audit |
| | | 13. Recommended inspection frequency checklist |
| | | 14. Completed inspection forms; master copies of forms |
| | | 15. Remedial action history: |
| | | a. Telephone complaints |
| | | b. Work Orders |
| | | 16. Accident and Incident Reports (w/ names blacked out) |
| | | 17. Accident Investigation Reports (w/ names blacked out) |
| | | 18. Accident summary reports or studies |
| | | 19. Other |
| | | 20. Other |
| | | 21. Other |

IMPORTANT: This information has been prepared to assist the owner's attorney in defending potential litigation. Do not release to any person except an agency official, insurance representative, or an investigating police officer.

High Frequency Inspection Form

Site Name/Code: _____

Inspector Name: _____ Date: _____ Start/Finish Times _____ / _____

Repairer Name: _____ Date: _____ Start/Finish Times _____ / _____

Use the following codes: 1 = Okay 2 = Needs Maintenance 3 = Request for Repair
 O = Supervisor Notified and Work Order Written X = Corrective Action Complete

| General Inspection Items | Code | Inspection Comments | Repair Comments |
|--|------|---------------------|-----------------|
| Vandalism: Damage, graffiti, glass, trash, etc. | | | |
| Loose or missing hardware | | | |
| Chains (kinked, twisted, broken) | | | |
| Components secure (no loosening) | | | |
| Swing Seats (cut, cracked, missing) | | | |
| Wood (rotten, cracked, missing) | | | |
| Remove foreign objects (ropes, chains, wood, etc.) | | | |
| Sweep walkways, platforms, steps | | | |
| Footers (concrete) exposed | | | |
| Standing water | | | |
| Objects in surfacing material | | | |
| Rake loose surfacing material level | | | |
| Need surfacing material for under: | | | |
| Swings | | | |
| Climbers | | | |
| Sliding Poles | | | |
| Slide | | | |
| Others | | | |

For official use only

Approved by _____ Date _____

Reviewed by _____ Date _____

This form has been prepared to assist the playground owner's attorney in defending potential litigation.
 DO NOT release to any person except an owner's official or designated claim representative, or an investigating officer.

Use back of form for additional comments.

Report all vandalism to building principal and/or your maintenance supervisor.

DRAFT Accident/Incident Report

Member Name: _____

Name of person completing report: _____ Date: _____

| General Liability Claim | | | |
|---|-------|---|------|
| Bodily Injury <input type="checkbox"/> Property Damage <input type="checkbox"/> | | | |
| Location of Incident | | | |
| Date of Accident: _____ Time of Accident: _____ | | | |
| Location/Address: _____ (name of park, pool community center, facility, etc.) | | | |
| Specific Location: _____ (playground, parking lot, gym, etc.) | | | |
| Bodily Injury | | | |
| Name of Injured Person: | | DOB: | Sex: |
| Address: | City: | State: | Zip: |
| Home Phone: | | Business/Daytime Phone: | |
| Part of body injured: | | Nature of injury: | |
| Brief factual summary of incident: (no speculation or opinions) | | | |
| Did injured person make any statements? <input type="checkbox"/> Yes <input type="checkbox"/> No If so, what was said? | | | |
| Was First Aid Administered? <input type="checkbox"/> Yes <input type="checkbox"/> No | | | |
| By whom: (name and position) _____ | | | |
| What first aid was given? _____ | | | |
| Paramedics Services Offered? <input type="checkbox"/> Accepted <input type="checkbox"/> Refused | | Police Called? <input type="checkbox"/> Yes <input type="checkbox"/> No | |
| Paramedics Called? <input type="checkbox"/> Yes <input type="checkbox"/> No (When in doubt, call for paramedics services.) | | Police Dept. _____ Officer: _____ | |

| Bodily Injury (continued) | | | |
|---|-------------------------|--|-------------|
| Parents/Relatives Notified? <input type="checkbox"/> Yes <input type="checkbox"/> No | | | |
| By whom: _____ | | Phone: _____ | |
| Parent/relative name: _____ | | Phone: _____ | |
| Relationship to injured person? _____ | | | |
| Witness Information | | | |
| Name: _____ | | | |
| Home Phone: _____ | | Business/Daytime Phone: _____ | |
| Address: _____ | | | |
| City: _____ | | State: _____ | Zip: _____ |
| Relationship to injured party: | | | |
| ____ Relative/friend (specify) _____ | | | |
| ____ Another program participant or park user | | | |
| ____ Passer-by | | | |
| ____ Employee or volunteer | | | |
| ____ Other (specify) _____ | | | |
| Did witness make any statements? <input type="checkbox"/> Yes <input type="checkbox"/> No | | | |
| If so, what was said? (Attach more pages if necessary) | | | |
| | | | |
| Third Party Property Damage (damage to non-agency property) | | | |
| Name of Property Owner: | | | Sex: |
| Address: | City: | State: | Zip: |
| Home Phone: | Business/Daytime Phone: | | |
| Property damaged was: | | | |
| Explain how damage occurred (facts only, no opinions): | | | |
| | | | |
| Estimated Cost to Repair? | | Estimates attached? <input type="checkbox"/> Yes <input type="checkbox"/> No | |

2022 Playground Study Report

Prepared for the City of Salem Public Schools, in Massachusetts

In-Person Training

Note: Salem schools should identify those personnel that maintain the school playgrounds. Training will be held TBA.

- *PINE will provide examples of High and Low Frequency Inspections and explain the difference.*
- *PINE will provide a copy of "The Daily Dozen". This information is a very good guide when looking to identify hazards during high frequency inspections.*
- *PINE will provide copies of the CPSC Guidelines (Consumer Product Safety Guidelines) and a general overview of its content and implications.*
- *Record-keeping: who, what, where and how.*
- *Discuss Manufacturers and Manufacturers' Representatives responsibilities*
- *Warranties: How they should be used and how you may unknowingly VOID them.*

PHASE 3: PLAYGROUND PLANNING



As lack of resources, materials, and space may increase prices for play equipment, we remain optimistic that technology and a deeper environmental awareness may lead to better, compact, and multifunctional play equipment designs, that can be modular or recycled to fit the ever-changing needs of the new generations. Although materials, designs and technology may change with time, we realize that one thing will remain constant: the need for a child to learn and develop through play outside, and in whatever form this may be, physical developmental stages will remain the same, i.e., walk, climb, jump, run, skip, swing, slide, hide, spin, bounce, skip...

2022 Playground Study Report

Prepared for the City of Salem Public Schools, in Massachusetts

OBJECTIVES

The objective of this section is to provide a framework for the City of Salem’s School Playground Stakeholders to move forward on the planning and management implementation of the existing and new playgrounds, based on realistic goals, and Standards of Care. Phase 3: Playground Planning will:

1. Provide planning recommendations for repair, maintenance, and management of **existing** school playgrounds
2. Summarize the **existing** playground and site planning recommendation based on Phases 1 and 2 findings and based on conversations with the school stakeholders.
3. Recommend general planning for **new** school playgrounds.



Figure 1: Example of Playground Master Plan developed for the Town of Shrewsbury. Design By PINE and M3 Land Studio, Rendering by M3 Land Studio

GENERAL PLANNING RECOMMENDATIONS FOR EXISTING SCHOOL PLAYGROUND IMPROVEMENTS



Figure 2: General Planning Recommendations for Existing School Playground Improvements diagram by M3 Land Studio

PLANNING RECOMMENDATIONS FOR REPAIR, MAINTENANCE AND MANAGEMENT OF EXISTING SCHOOL PLAYGROUNDS

At a critical level, the Owner should budget for consistent maintenance goals to cover a minimum “Standards of Care” (which would be Safety and Compliance). Based on the Playground Assessments, and summarized on the Status Grid, the following are our recommended **Priority Action Items**:

1. *Attend to all **Hazard 1’s**: Broken slides, play equipment and parts.*
2. *Decide on a general strategy for when it is feasible to repair, retrofit, or replace the **play equipment and adjacent site features**. Our recommendation is to replace for new equipment those playgrounds that are too outdated and in disrepair. Retrofits or part replacement on these outdated playgrounds would not be cost effective for the Owner. (For a visual summary per school playground, refer to the diagram below).*
3. *Start on a **Systematic Record-keeping** for New/Newer Existing Play Equipment. Keep all manufacturer information handy and to include:*
 - a. *2D Layouts*
 - b. *Operation and Maintenance (O+M) Manuals from Manufacturer*
 - c. *Maintenance Kits for new equipment is a requirement of the manufacturer to the Owner (see CPSC).*
 - d. *Installation Instructions and Specifications (ships with the equipment and should be kept with records)*
 - e. *Keep a calendar for Testing Recommendations (Inspections, etc.)*
4. *Decide on a general and effective strategy for maintenance and MAAB compliance of existing **EWF safety surfacing** (\$ = Less expensive, higher maintenance to \$\$\$ Most expensive but lower maintenance):*
 - a. *Use a concrete apron to access*
 - b. *Make sure edging is sturdy, level, and at a height greater than or equal to the marked playground post, for **Fall Height** safety compliance.*

2022 Playground Study Report

Prepared for the City of Salem Public Schools, in Massachusetts

- c. \$: Use ADA / "Grass Mats" over EFM, like Saltonstall Playgrounds.
 - d. \$\$: Use PIP 5' wide circulation paths to each transfer or ADA accessible play component. NOTE: This PIP path also serves as a datum to level EWF throughout the playground.
 - e. \$\$\$: Change all safety surfacing to PIP.
5. General strategy for existing **PIP safety surfacing**:
- a. Keep records of manufacturer's material and installation warranties
 - b. Keep sample colors for repairs or resurfacing
 - c. Ask for extra polyurethane coats to prevent immediate wearing of EPDM granules
 - d. Keep O+M manuals with all record-keeping and follow manufacturers' recommendations for repairs and maintenance to avoid voiding warranties.

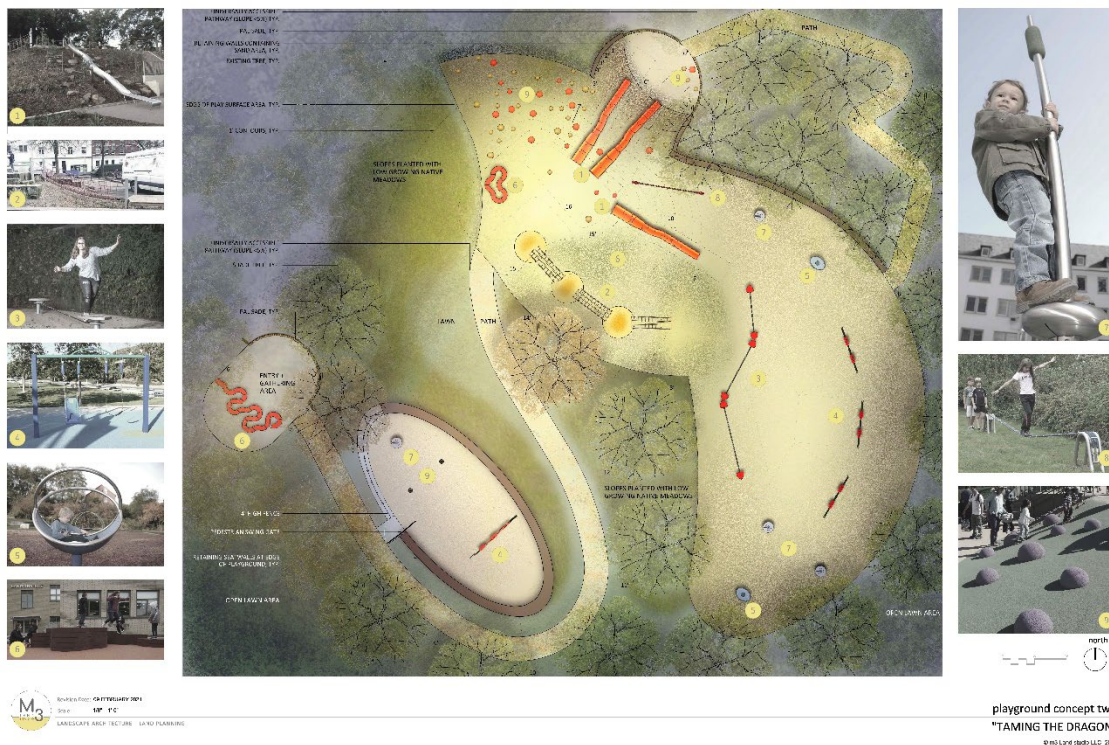

Figure 3: Playground Master Plan Design and Rendering by M3 Land Studio

2022 Playground Study Report

Prepared for the City of Salem Public Schools, in Massachusetts

PLANNING RECOMMENDATIONS PER EXISTING SCHOOL PLAYGROUND



Figure 4: Planning Recommendations per Existing School Playground, diagram by M3 Land Studio

PLANNING RECOMMENDATIONS FOR NEW SCHOOL PLAYGROUNDS

Based on the online survey and our playground assessment observations, this feedback should help the Owner develop a Capital Management Plan and ADA Recommendation Report.

Please note that we do not pursue grants or means of funding on behalf of our clients. We, however, can advise on types of funds/grants that the City of Salem can pursue. M3 Land Studio can provide design renderings and/or narratives to include in grant applications, as a separate/additional service contract to this one.

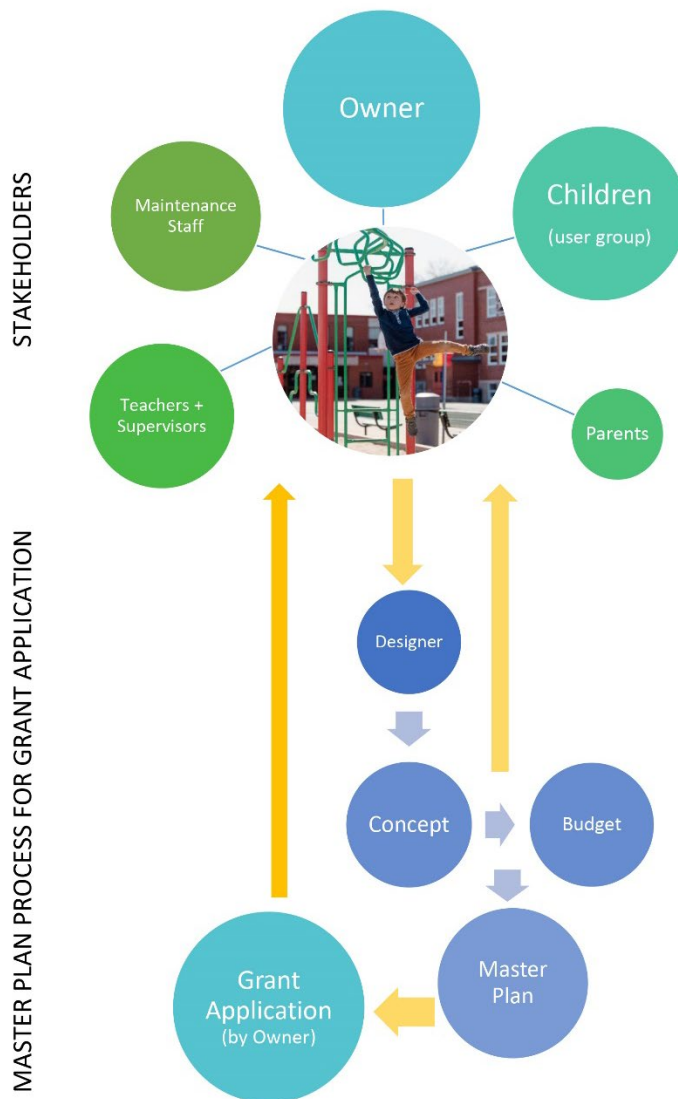

Figure 5: Planning for a New Playground, diagram by M3 Land Studio

2022 Playground Study Report

Prepared for the City of Salem Public Schools, in Massachusetts

GENERAL DESIGN PRINCIPLES FOR NEW SCHOOL PLAYGROUNDS

Every child at every school, in every town has different needs. Owner's need to provide the appropriate activities for growth and development. One of the first times a child understands the principles of sharing is at the playground.

- **Playground location** in relation to the school building should address issues of access, circulation, and site safety. Convenience, containment, and site visibility are important when a limited number of supervisors are responsible for many users at one time. Teachers from various other public schools have mentioned that when the playground is far from the classroom/school, not easily accessible by everyone or not contained, it is underused. Other items to consider when siting a new playground or rebuilding an existing one:
 - Microclimate- shade/sun, wind exposure. Where possible use natural elements such as berms, trees, and small shrubs for enclosure and comfort.
 - Site amenities- in a visually advantageous location as well as in comfortable spaces to promote different activities/programs such as picnic/game tables, social and group interactions, or outdoor class use.
 - Proximity to other amenities that can be used by students at the same time- such as a garden, field, court, or pavement with painted games.
- **Playground Carrying Capacity** a new/renovated playground should consider the maximum number of students using the playground at any given time. Currently, and for most schools, that number is 60 students. The designer should also consider overall student population increase trends in each school, which most of the time result in more students using the playground at a given time and/or an increase in the frequency of the use of the playground. When the carrying capacity of a playground is high, we recommend that the play equipment choices are of superior quality and high play value.
- **Play Value** as defined in the first section of this report, has to do with the degree to which a playground and its equipment offers multiple layers of opportunities and experiences to engage the users to develop social, physical, intellectual, and moral skills through play. This is very subjective however, some trends are true throughout our years

2022 Playground Study Report

Prepared for the City of Salem Public Schools, in Massachusetts

of designing and reviewing playgrounds; swings, slides and climbers are popular for most elementary school aged children. Some typical examples of “High Play Value Equipment” are:

- *Play structures that encourage exploration, diverse range of motion, and have a high carrying capacity (25 plus users at a time, for example).*
 - *Swings that can hold more than one student and provide the motion for children of all abilities.*
 - *Multifunctional play components that engage many users and encourage collaboration (such as spinners/climbers)*
 - *Free standing play equipment that can be linked or grouped allowing for independent activities while providing visual proximity to other users. This also spreads children out for supervision.*
 - *Play equipment that can encourage creativity that would include hiding, pretend play, moving parts and cooperation with other users for the enhancement of experiences!*
- **Access, Circulation, and Flow** (from outside and inside the playground). *Inclusivity is the new standard in current playground design. A playground should be universally accessible to engage and challenge all! Without proper circulation and design flow, playgrounds can seem disjointed or even unsafe when there is a larger volume of users at a time.*
 - **Inclusive Play and Universal Design (UD)**³ *is the normal grant guidelines such as those developed by programs like the MSBA (Massachusetts School Building Authorities) that require the opportunity to engage all playground users. Inclusivity is no longer*

³ (UD) is an approach that promotes the use of all design parts by everyone, as much as possible. In addition to physical universal accessibility, UD focuses in sensory, cognitive, social, and emotional abilities to create an environment that is welcoming to all people to the greatest extent possible.

2022 Playground Study Report

Prepared for the City of Salem Public Schools, in Massachusetts

limited to access but extends to the experience and level of interaction with all play events by diverse users.

- **Outdoor Classrooms and Nature-based Play** are the latest trends in school playgrounds, especially with COVID, teachers and parents have realized the importance of outdoor play areas for learning and interacting with peers, for physical, mental, and social well-being. Teachers should take advantage of outdoor spaces to extend their curriculum outside and provide more hands-on experience, as it has been proven to be one of the best learning approaches. Small outdoor learning labs could be incorporated in the playground, and these could reflect the school's interest or learning approaches such as STEAM⁴. Ideally, proximity of playgrounds to classrooms, fields, natural resources/open spaces will allow for students to choose "their own adventure", experience changing seasons, etc., without being restricted to a small play space with the same play equipment.
- **Budget Wisely:** high play value, superior material and design quality, and low maintenance is the way to obtain support, not only financially but from an environmental and cultural sustainability point of view. (How well it can adapt to its site context, school's cultural identity and learning approach, etc.)
- **Surfacing:** is the most important aspect of a playground. Falling off equipment is the number one reason children get hurt. It is the fall to the surface, not the equipment.

CONCLUSION OF REPORT

This report has a great deal of information that touches upon "what you have, what you need to fix, how to fix it, and how to move forward". Feel free to contact PINE or M3 Land Studio should you need further assistance in the future.

Thank you for affording us the opportunity to assist you!

⁴ STEAM (formally STEM) is a forward-thinking, integrated approach to learning that uses Science, Technology, Engineering, the Arts and Mathematics to guide children's questioning, critical thinking, and dialogue.

2022 Playground Study Report

Prepared for the City of Salem Public Schools, in Massachusetts

PINE DISCLAIMER

Playground Inspection Disclaimer (either Low, High, ReVisit or Assessment):

- *Playground Inspections of New England, LLC ("PINE") bases its playground inspection procedures on the standards of both the American Society for Testing and Materials ("ASTM") and the U.S. Consumer Product Safety Commission ("CPSC"), as those may be amended from time to time.*
- *At the completion of the inspection, PINE will furnish to the customer a written report (the "Inspection Report") which shall identify possible noncompliance with ASTM 1487-17 and CPSC standards and which shall make recommendations with regard to further investigation (the "Inspection Results"). The inspection and the Inspection Report shall cover only the playground with respect to which PINE has been engaged to inspect (the "Playground"). The Inspection Report shall only reference the conditions of the Playground on the date of the inspection, which date shall be specifically provided for in the Report (the "Inspection Date"). It is specifically understood that PINE shall not perform any repairs or maintenance on the Playground as that is the sole responsibility of the customer.*
- *PINE shall have no liability whatsoever with regard to any change in the condition of the Playground from and after the Inspection Date.*
- *PINE shall have no liability relating to the Playground or the Inspection Report or relating in any way to any loss, cost, liability, damages, claims or suits whatsoever relating to the same unless due solely to the gross negligence or willful act of PINE.*
- *An inspection or assessment of a playground is not an audit of said playground, but is rather a more generalized review designed to alert the customer to possible noncompliance with ASTM 1487 and CPSC and the Inspection Report is not to be deemed to be a certification as to the safety of the playground or its compliance with ASTM 1487 and CPSC.*

M3 LAND STUDIO DISCLAIMER

M3 Land Studio is a Landscape Architect and as such carries no liability in the playground assessments as it relates to playground equipment and surfacing.

REFERENCES

Consumer Product Safety Commission Guidelines

American Society of Testing Materials

US Department of Justice American with Disabilities Act

Massachusetts Architectural Access Boards

"Playground Safety is No Accident" by Ken Kutska, CPSI

APPENDIX



2022 Playground Study Report

Prepared for the City of Salem Public Schools, in Massachusetts

A. Online survey

1. What school are you from

20 responses

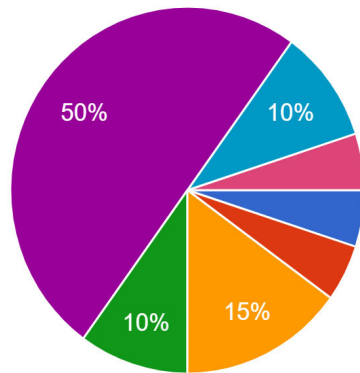

- Bates Elementary School
- Salem Early Childhood School
- Bentley Academy Innovation School
- Saltonstall School
- Horace Mann Laboratory School
- Witchcraft Heights Elementary School
- Carlton Innovation School

2. How many playgrounds does your school have?

19 responses

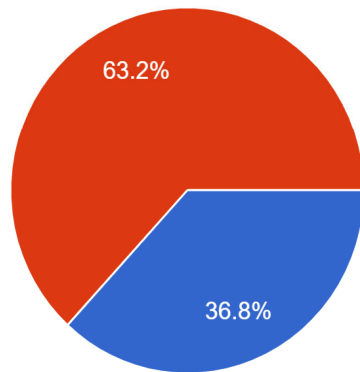

- 1
- 2

4. Over the past years, what has been the trend in the number of students?

19 responses

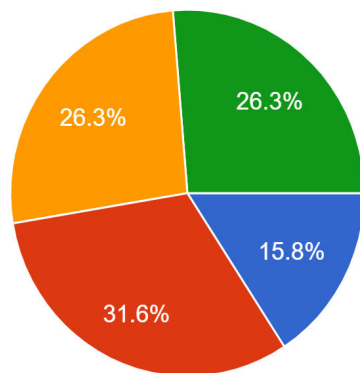

- Increase
- Same
- Decrease
- Don't know

5. Do all the students use the existing playground(s)?

19 responses

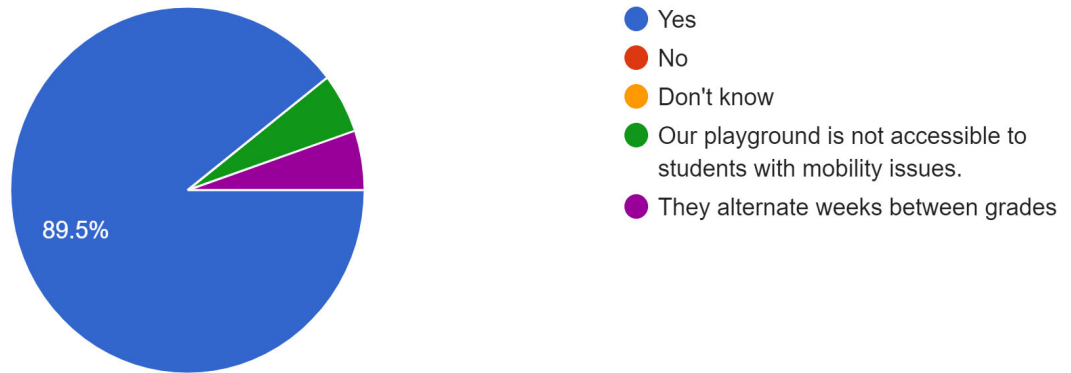

6. How many students are on each playground at the same time?

19 responses

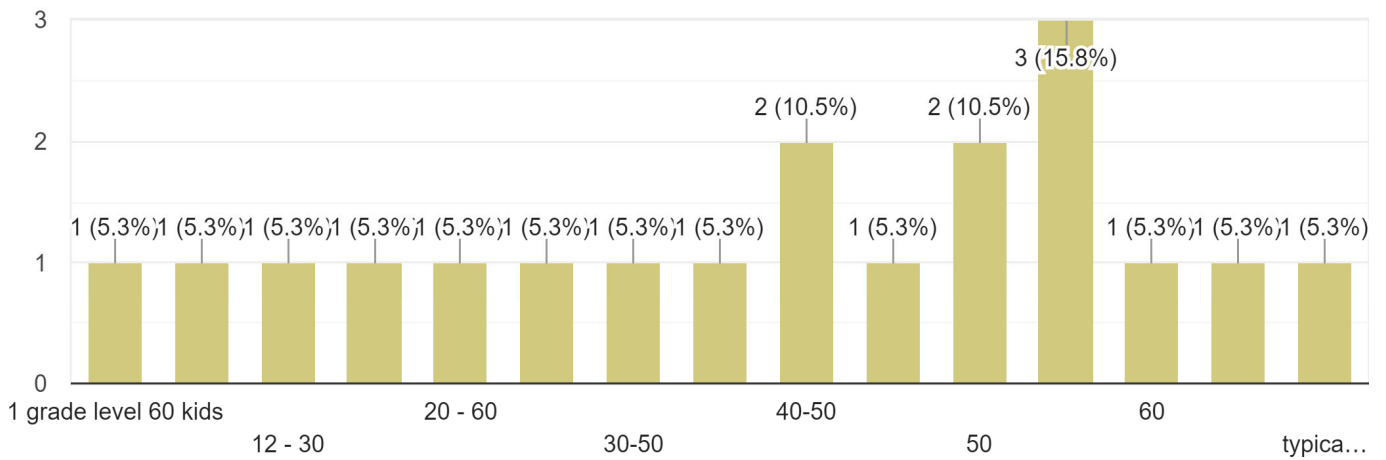

7. Who supervises the students when using the playground(s)?

19 responses

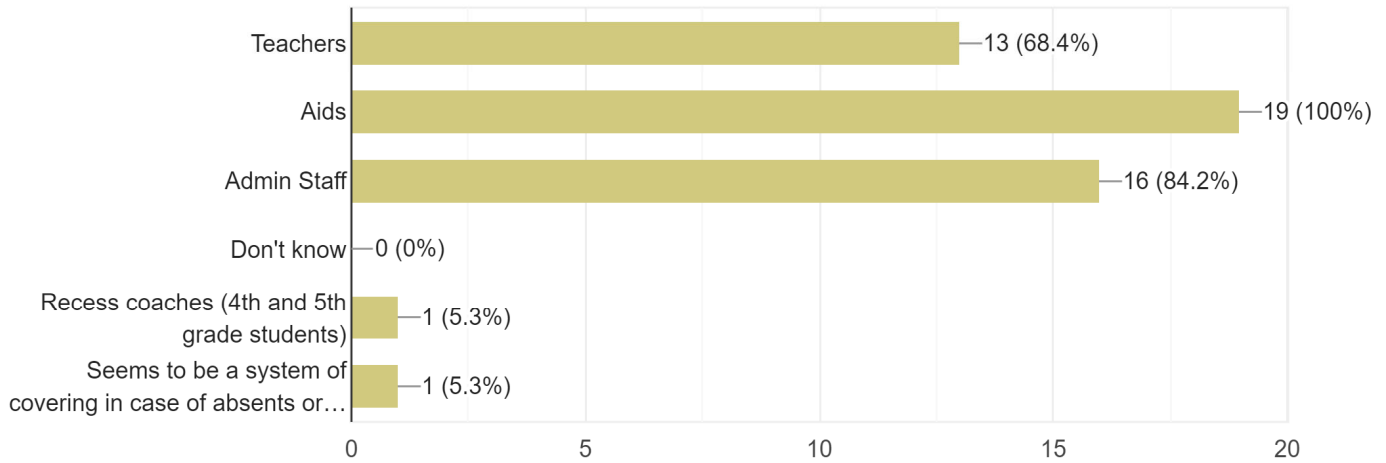

8. Do you believe that you have the appropriate number of staff supervising the students using the playground(s)?

19 responses

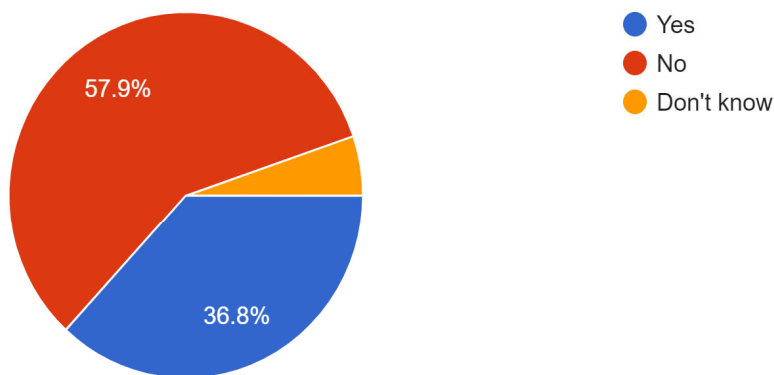

9. Based on the existing school population, do you believe that the amount of existing play equipment suffices the needs of the students?

19 responses

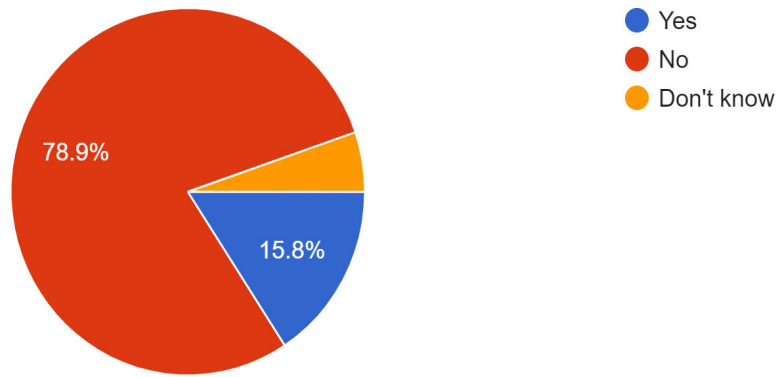

10. Which is/are the most used/popular play equipment?

19 responses

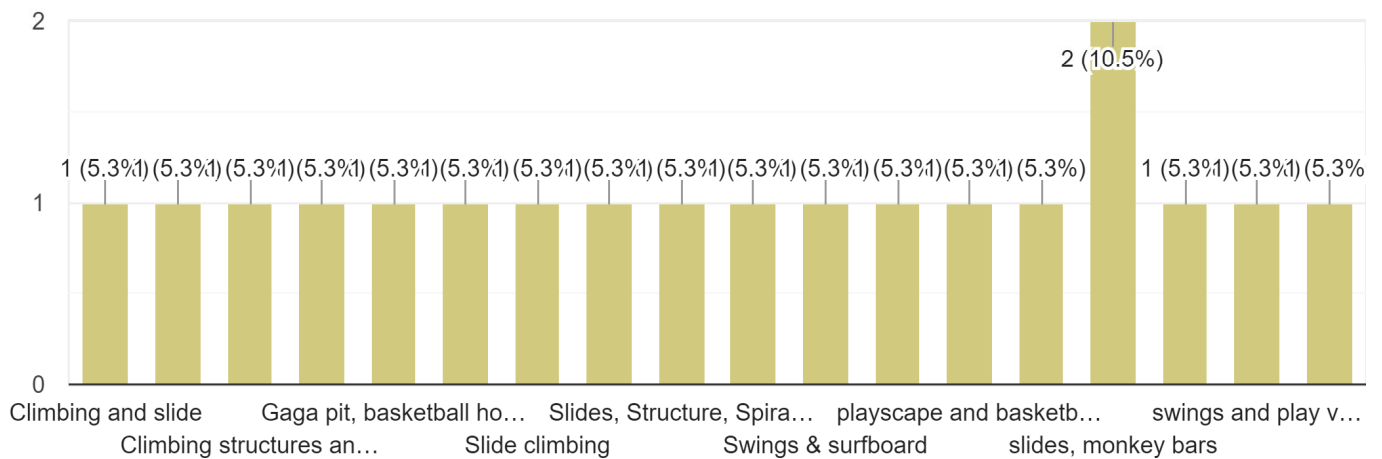

15. Is/Are your playground(s) used after school? (Evenings, weekends, vacation, holidays, summer)
19 responses

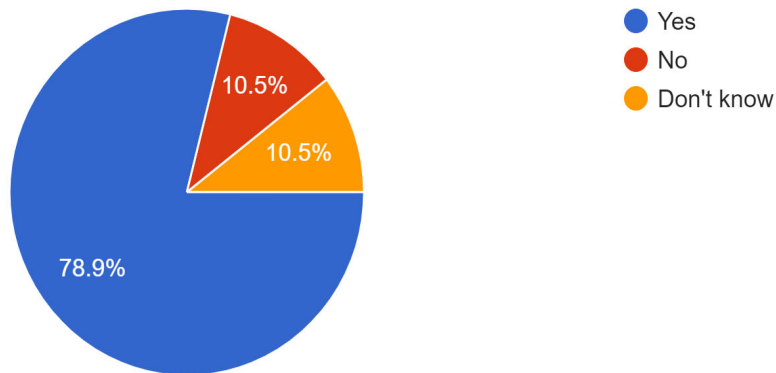

16. Is/Are your playground(s) used after school:
19 responses

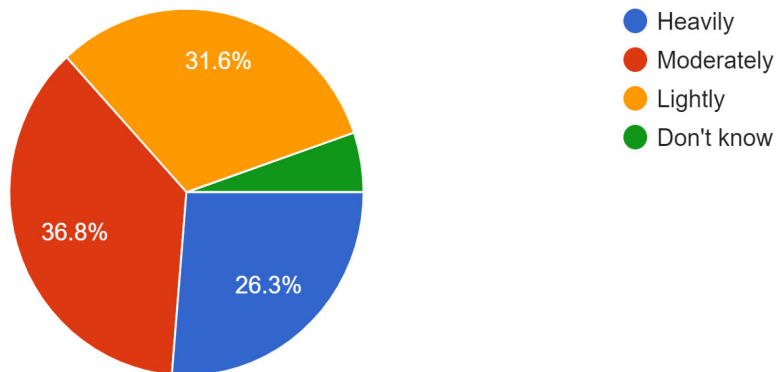

17. Are there non-school programs that use your playground(s)? For example a Boys and Girls Club, YMCA, etc.
19 responses

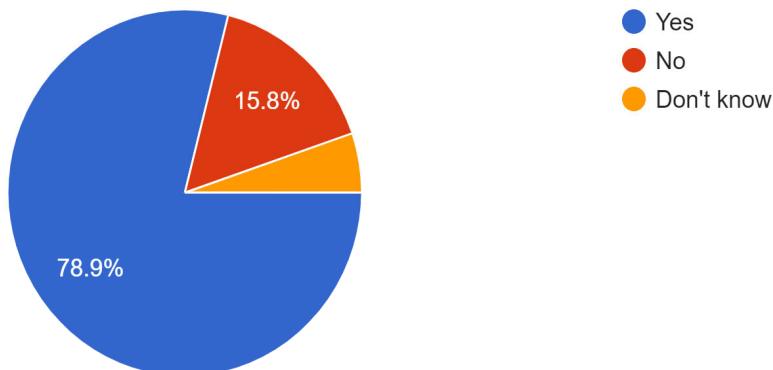

19. How often is/are the playground(s) maintained?

18 responses

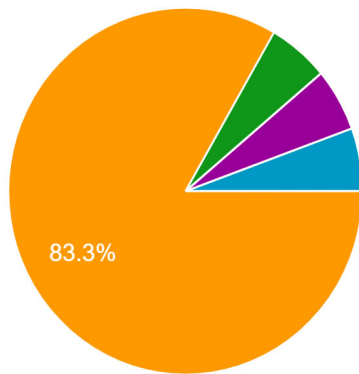

- Daily
- Weekly
- Don't know
- As needed
- Very infrequently. Our playground is used heavily by students and neighborhood kids. There needs to be better maintenance, trash collection. PTO has tried to maintain the painted...
- Once a year or every few years

20. Who is notified of a broken playground piece the moment it is noticed?

18 responses

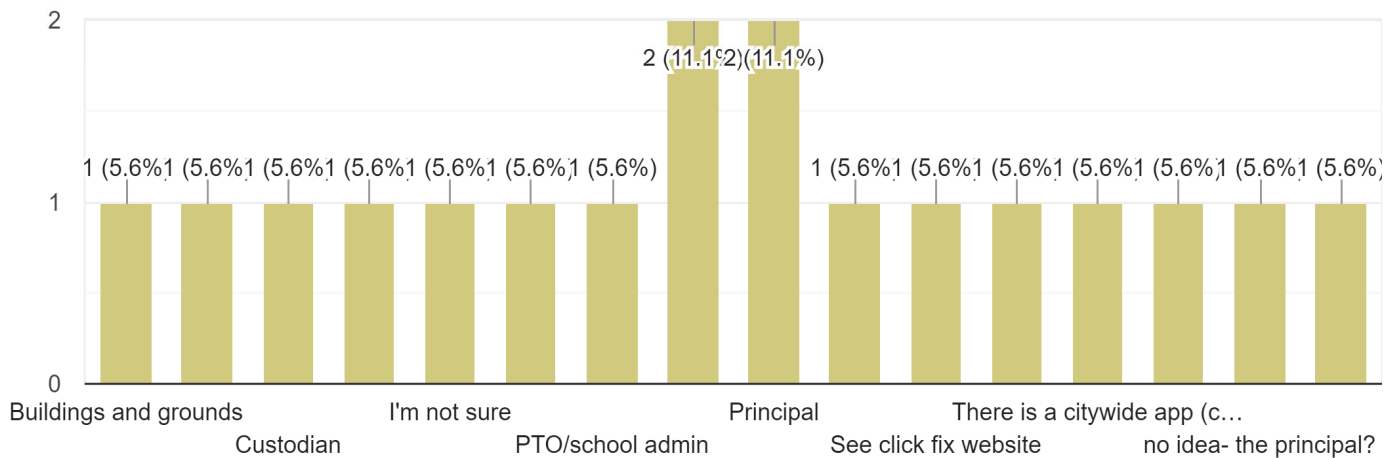

21. Do you have a standard protocol when play equipment is broken or needs fixing?

18 responses

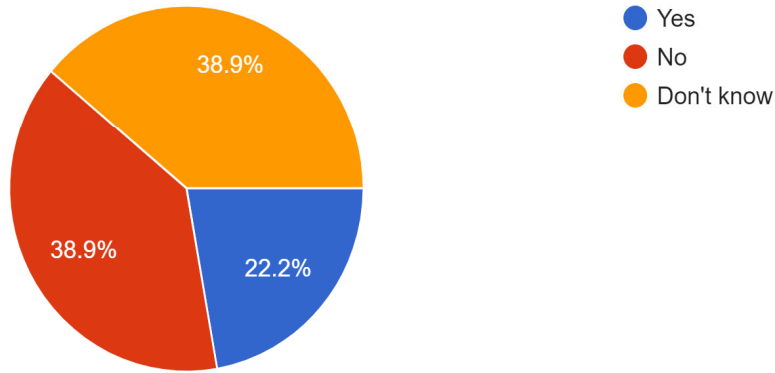

22. Do you have safety concerns about the playground(s)?

18 responses

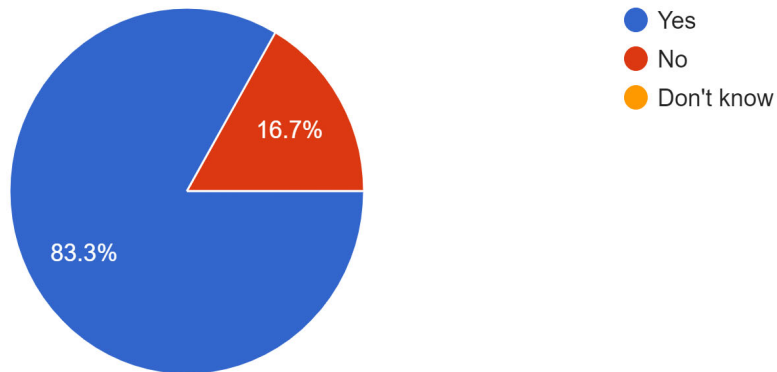

2022 Playground Study Report

Prepared for the City of Salem Public Schools, in Massachusetts

B. Full Size Playground Layouts/ PDFs by Manufacturers

The 2D Layouts obtained from the Playground manufacturers are for the following public school playgrounds:

1. *Bates Elementary School 5-12 Y.O. Playground by Playworld*
2. *Salem Early Childhood School (not current)*
3. *Bentley Academy Innovation School by LSI*
4. *Saltonstall School 5-12 Y.O. Playground by LSI*
5. *Witchcraft Heights Elementary School by Playworld (not current)*

The following schools are missing 2D Layouts due to age of playgrounds:

1. *Bates Elementary School 2-5 Y.O. Playground by Playworld*
2. *Saltonstall School Kindergarten Playground by Playland*
3. *Horace Mann Laboratory School (BOTH PLAYGROUNDS) by Playworld*



P.O. Box 374
Uxbridge, MA 01569
866-575-7529
www.ultiplayus.com

AUG - 5 2016

August 1, 2016

Mr. Paul L'Heureux
Facilities Director
Salem Public School
29 Highland Ave
Salem, MA 01970

Re: Bates Elementary School
53 Liberty Hill Ave
Salem, MA 01970

Dear Mr. L'Heureux:

This letter is to inform you that with our completion and review UltiPlay confirms that the play equipment that was installed at the Bates Elementary School was completed in compliance with current ASTM guidelines for public playgrounds and also in compliance with manufacturer's specifications

In conclusion, please do not hesitate to contact our office with any questions that you may have concerning the installation of the play equipment. Please also notify me if you need any additional information and I hope the children enjoy their new play equipment.

Sincerely,

A handwritten signature in blue ink, appearing to read "Joe McMahon".

Joe McMahon
UltiPlay Parks & Playgrounds, Inc.
CPSI # 35020-619



Bates Elementary Sales Representative
School
Salem, MA
©2014 PlayWorld



Equipment Manufacturer
PLAYWORLD
The Best in the Industry

LET'S BUILD THE PLAYGROUND!



Can you help us?

We've purchased all the playground equipment, but we need volunteers to build it!

Our build days are July 2nd, 5th, 6th and 7th. If you can help on any of those dates, please go to <http://tiny.cc/batesplayground> and sign up! No building experience necessary!

Whether you can sign up for a few days or just a few hours, we need you! Lunch and childcare will be available.

Build Days

Saturday, July 2nd, 8:00am-4:00pm

Tuesday, July 5th, 8:00am-4:00pm

Wednesday, July 6th, 8:00am-4:00pm

Thursday, July 7th, 8:00am-4:00pm

Contact: Sarah Murphy

Phone: 978-335-2538

Email: sarahemurphy37@gmail.com

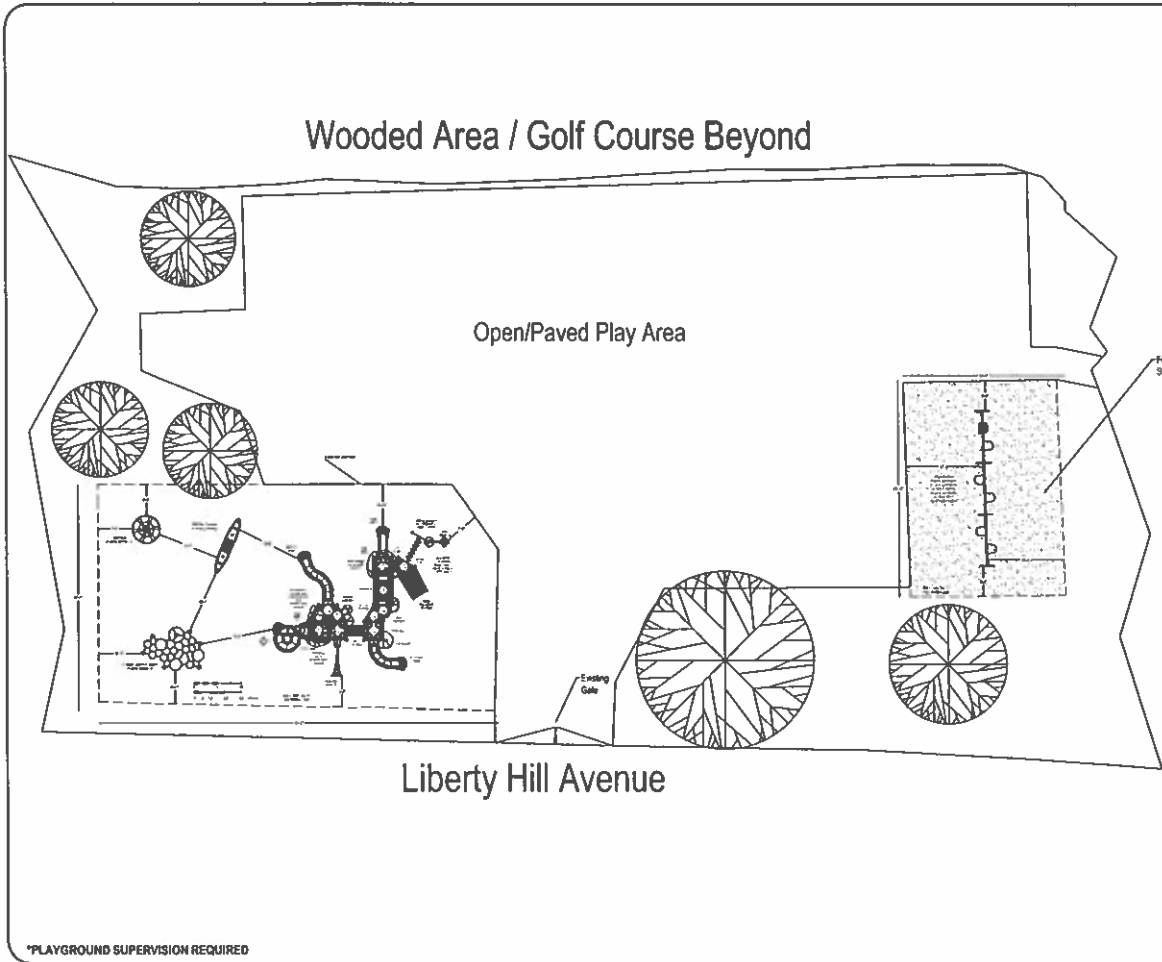

ULTIPLAY PARK &
PLAYGROUNDS, INC.
P.O. Box 374
Uxbridge, MA 01569
866-575-PLAY

EQUIPMENT SIZE
SEE DRAWING

USE ZONE
SEE DRAWING

AREA PERIMETER
SEE DRAWING SEE DRAWING

FALL HEIGHT
9 FT.

USER CAPACITY AGE GROUP
82 5-12

- ✓ ASTM F1487-11
- ✓ CPSC #325



| | |
|---------------------------|------------------------|
| PROJECT NO. 14-5161G | SCALE NTS |
| DRAWN BY JEFF WILLIAMS | Paper Size B |
| DATE 10-28-16 | |

BATES ELEMENTARY SCHOOL
SALEM, MA 01970

*PLAYGROUND SUPERVISION REQUIRED

Bates

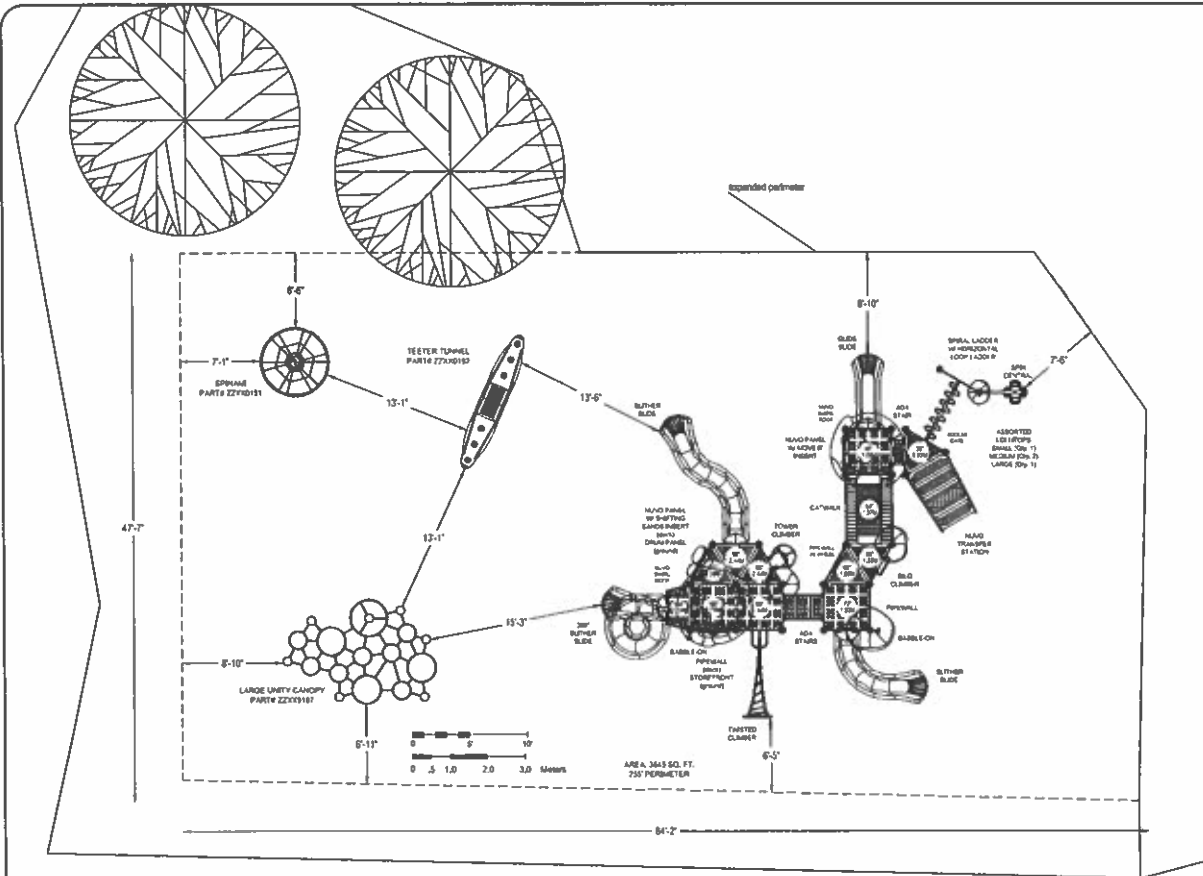

PLAYWORLD

ULTIPLAY PARK &
PLAYGROUNDS, INC.
P.O. Box 374
Uxbridge, MA 01569
866-575-PLAY

EQUIPMENT SIZE
35'X37'X18'

USE ZONE
48'X65'

AREA PERIMETER
3845 SqFt. 255 FL.

FALL HEIGHT
9 FL.

USER CAPACITY AGE GROUP
82 5-12

| ADA SCHEDULE | Total Elevated Play Activities 11 | | |
|--------------|-----------------------------------|------------------------------------|--|
| | Accessible Standard Activities | Accessible Ground-Level Activities | Accessible Ground-Level and Play Types |
| Required | 8 | 4 | 3 |
| Provided | 11 | 7 | 4 |

- ✓ ASTM F1487-11
- ✓ CPSC #325



PROJECT NO. 14-5161G SCALE 1/8"=1'-0"

DRAWN BY JEFF WILLIAMS Paper Size **B**

DATE 10-20-16

BATES ELEMENTARY SCHOOL
SALEM, MA 01970

Liberty II

*PLAYGROUND SUPERVISION REQUIRED

Bates



Bates Elementary School Sales Representative
Salem, MA
N. IMPACT



Equipment Manufacturer



Bates



Bates Elementary Sales Representative
School
Salem, MA

ultiplay

Equipment Manufacturer
PLAYWORLD

Bates



Bates

Bates Elementary School Sales Representative
Salem, MA



Equipment Manufacturer
PLAYWORLD
The SafePlay® Brand

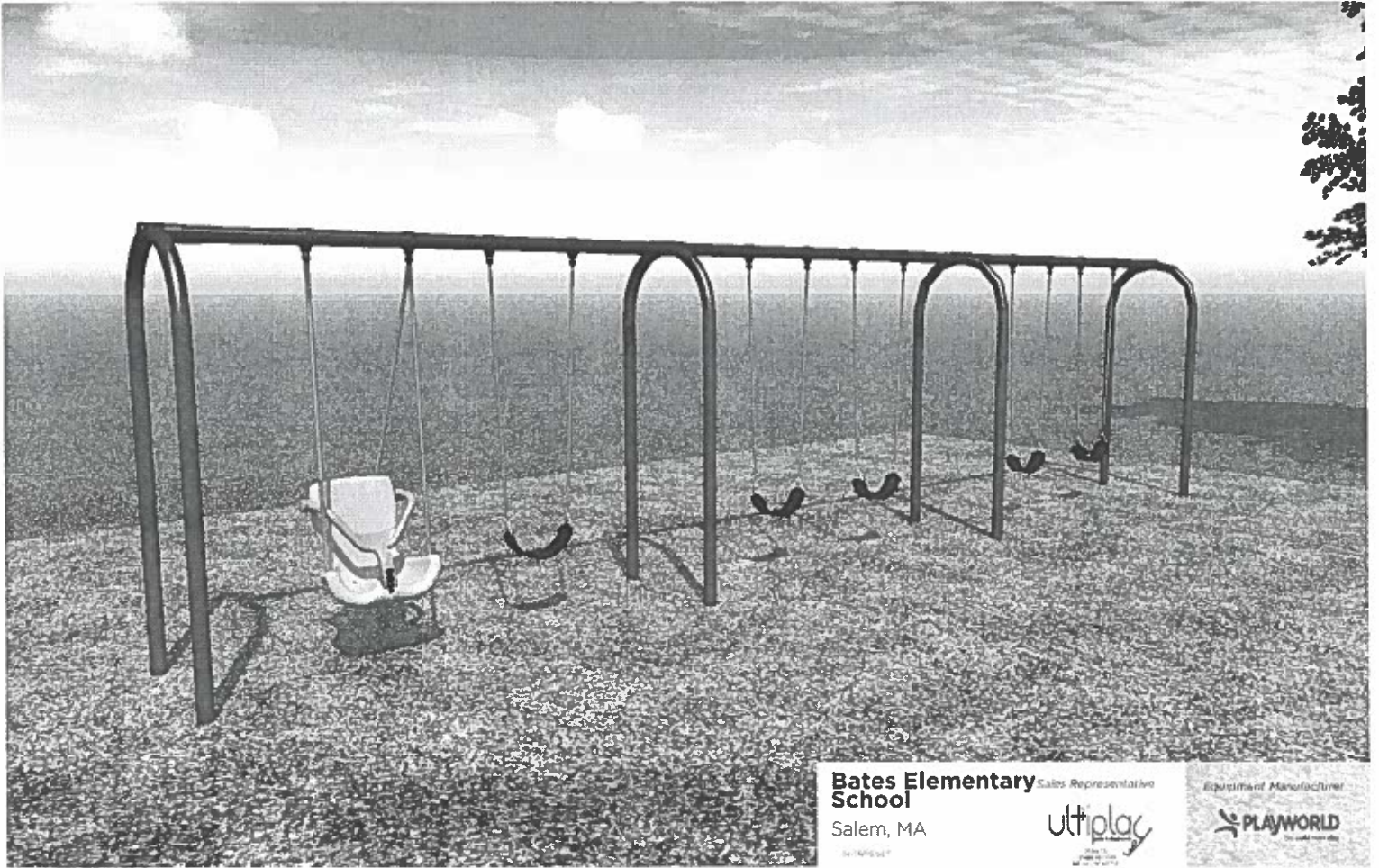

Bates Elementary Sales Representative
School
Salem, MA

ultiplay
PLAYERS IN THE GAME

Equipment Manufacturer

PLAYWORLD
The World's Best

Bates

3) TO COMPARTMENTS U play are provided.
6) At least one of each component is along

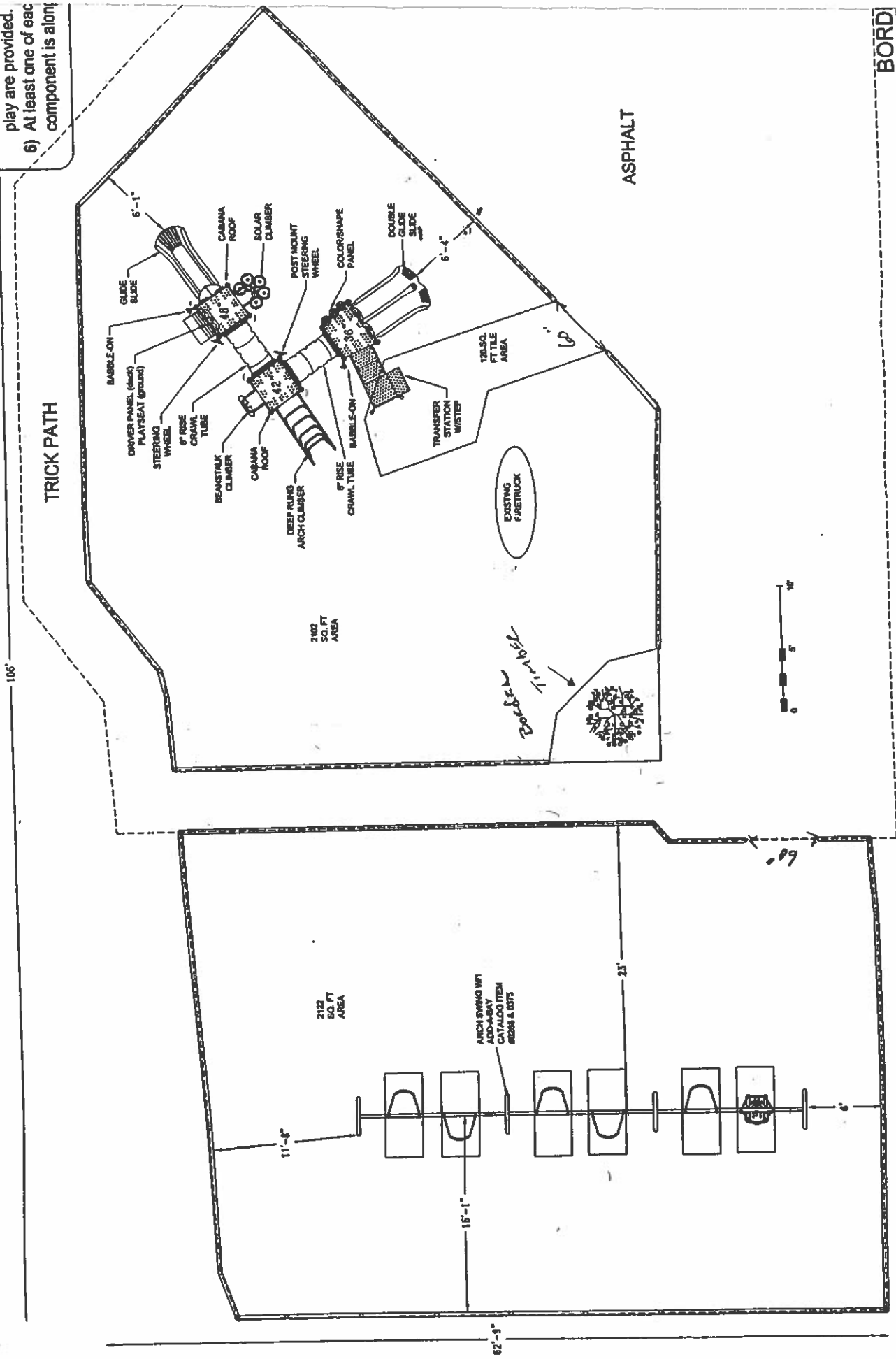

Salem ECC

Bentley



| | |
|------|-------|
| BORD | 50 - |
| | 5 - |
| | 3 - |
| | 4 - |
| | 3 - E |

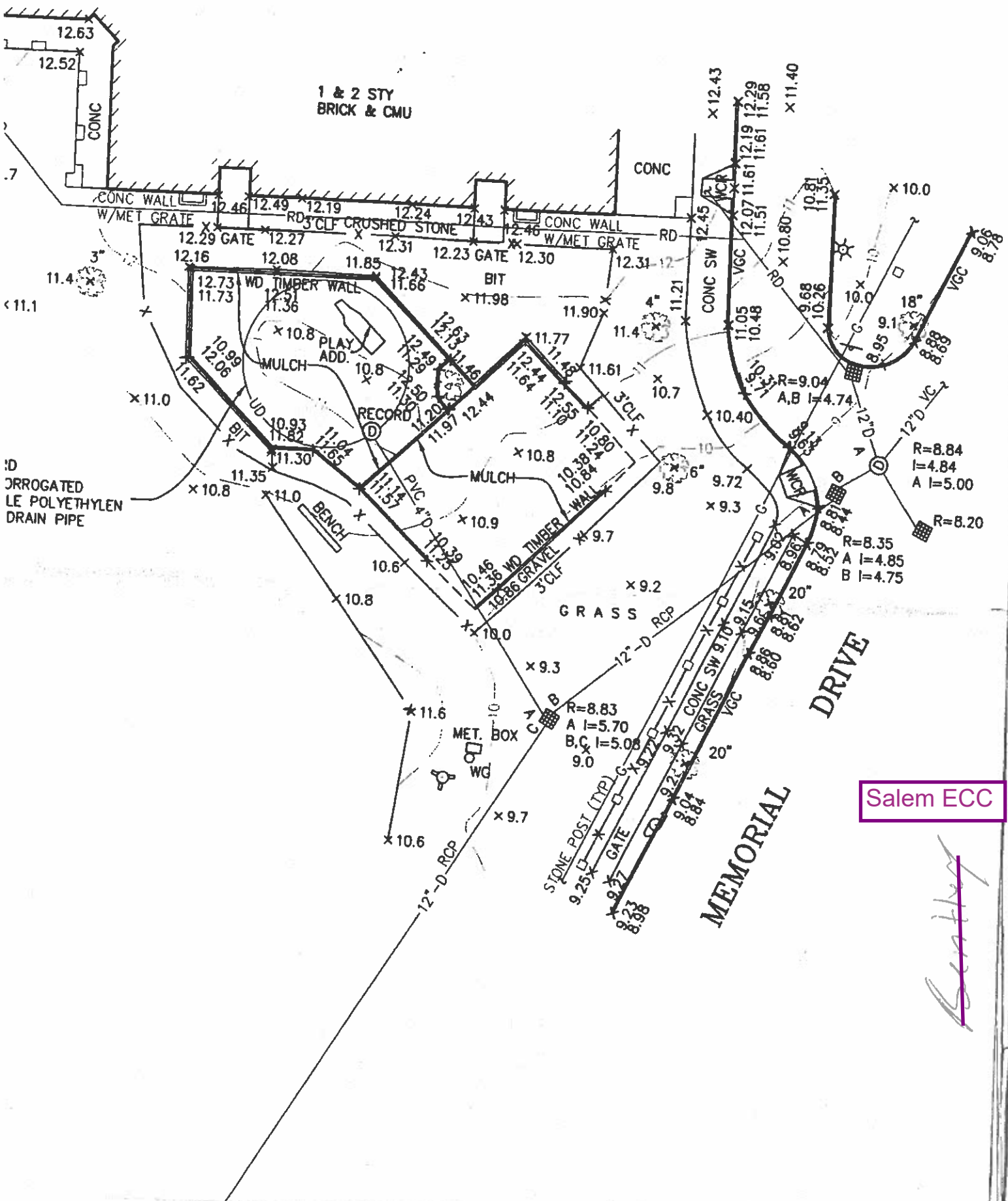

Salem ECC

Century

SCHOOL BUILDING

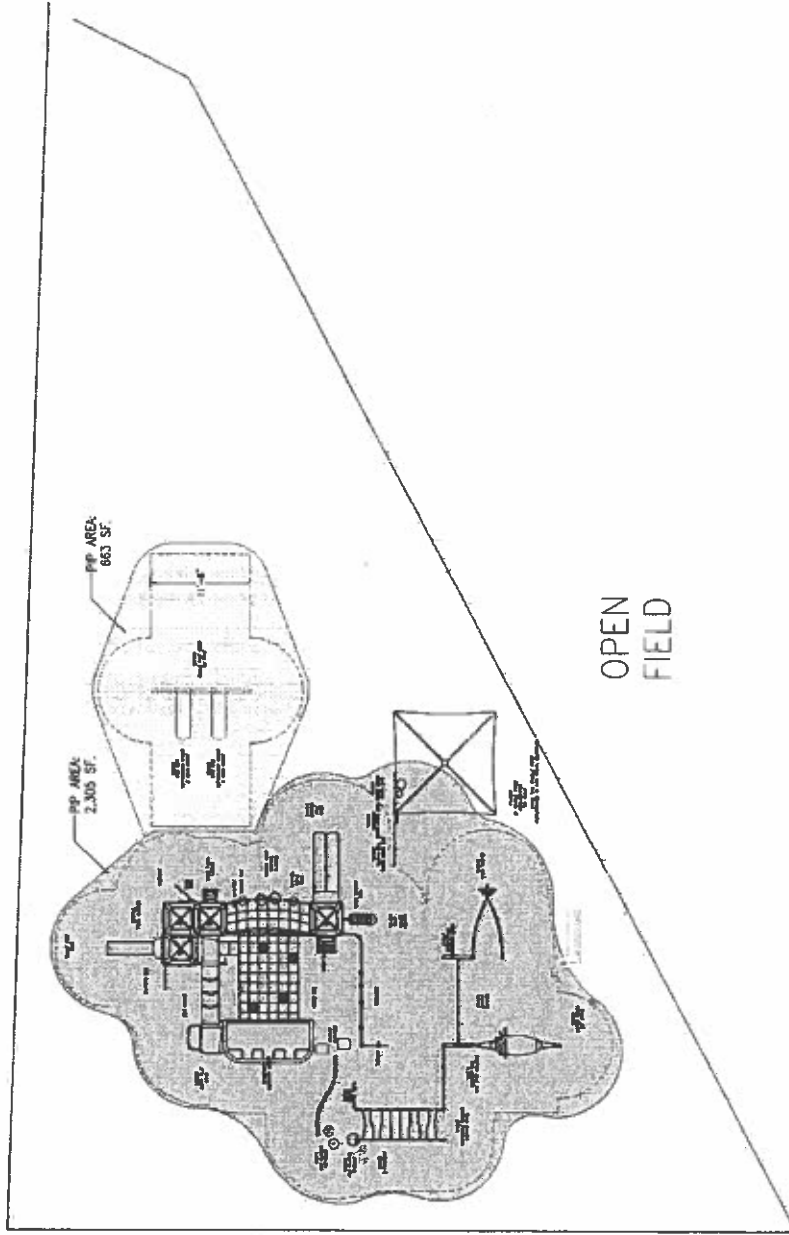

SCHOOL BUILDING

MAIN ENTRANCE

- TOTAL ELEVATED PLAY COMPONENTS 13
- TOTAL ELEVATED COMPONENTS ACCESSIBLE BY RAMP 0
- TOTAL ELEVATED COMPONENTS ACCESSIBLE BY TRANSFER 8
- TOTAL ACCESSIBLE GROUND LEVEL COMPONENTS SHOWN 17
- TOTAL DIFFERENT TYPES OF GROUND LEVEL COMPONENTS 7



BENTLEY ACADEMY CHARTER SCHOOL
 SALEM, MA

M.E. O'BRIEN &
 SONS, INC.
 ANDY BERGER

SYSTEM TYPE
 PB/EVOS/IND
 DRAWING #
 ME017190

landscape structures



TPM MAX CERTIFIED
 This play area & equipment is certified to meet the ASTM F1487 standard for public playground equipment. It is designed and manufactured in the USA by landscape structures, Inc.

THIS PLAY AREA & EQUIPMENT IS CERTIFIED TO MEET THE ASTM F1487 STANDARD FOR PUBLIC PLAYGROUND EQUIPMENT UNLESS OTHERWISE NOTED ON PLAN.

IF IS THE MANUFACTURER'S OPINION THAT THIS PLAY AREA DOES NOT COMPLY TO THE ASTM F1487 STANDARD FOR PUBLIC PLAYGROUND EQUIPMENT, ACCESSIBLE PLAYING SURFACING IS PROVIDED AS INDICATED, OR WITHIN THE CHUTE USE ZONE.

THE CONTRACTOR SHALL TAKE CARE TO PROTECT ALL UTILITIES AND STRUCTURES AVAILABLE TO THE PUBLIC TO REMAIN AND TO BE MAINTAINED. THIS INCLUDES BUT IS NOT LIMITED TO: UTILITIES, EXISTING AND PROPOSED, AND STRUCTURES, EXISTING AND PROPOSED. A UTILITY OR STRUCTURE SHALL BE PROTECTED BY THE CONTRACTOR. THE CONTRACTOR SHALL BE RESPONSIBLE FOR THE LOCATION OF ALL UTILITIES, STRUCTURES AND STRUCTURES TO BE PROTECTED. THE CONTRACTOR SHALL BE RESPONSIBLE FOR THE LOCATION OF ALL UTILITIES, STRUCTURES AND STRUCTURES TO BE PROTECTED.

CHOOSE A PROTECTIVE SURFACING MATERIAL THAT MEETS OR EXCEEDS THE ASTM F1487 STANDARD FOR PUBLIC PLAYGROUND EQUIPMENT. THE CONTRACTOR SHALL BE RESPONSIBLE FOR THE LOCATION OF ALL UTILITIES, STRUCTURES AND STRUCTURES TO BE PROTECTED. THE CONTRACTOR SHALL BE RESPONSIBLE FOR THE LOCATION OF ALL UTILITIES, STRUCTURES AND STRUCTURES TO BE PROTECTED.

IT IS THE MANUFACTURER'S OPINION AND BELIEF THAT THE LAYOUT OF THESE COMPONENTS MEETS THE ASTM F1487 STANDARD FOR PUBLIC PLAYGROUND EQUIPMENT. THE CONTRACTOR SHALL BE RESPONSIBLE FOR THE LOCATION OF ALL UTILITIES, STRUCTURES AND STRUCTURES TO BE PROTECTED. THE CONTRACTOR SHALL BE RESPONSIBLE FOR THE LOCATION OF ALL UTILITIES, STRUCTURES AND STRUCTURES TO BE PROTECTED.

DESIGNED BY:
 JRA
 COMPANY: G. O'BRIEN & SONS, INC.
 83 WEST STREET, SALEM, MA 01970
 PHONE: 508-538-8117
 FAX: 508-538-8117

| Date | Previous Drawing # | Notes |
|------|--------------------|-------|
| | | |
| | | |
| | | |



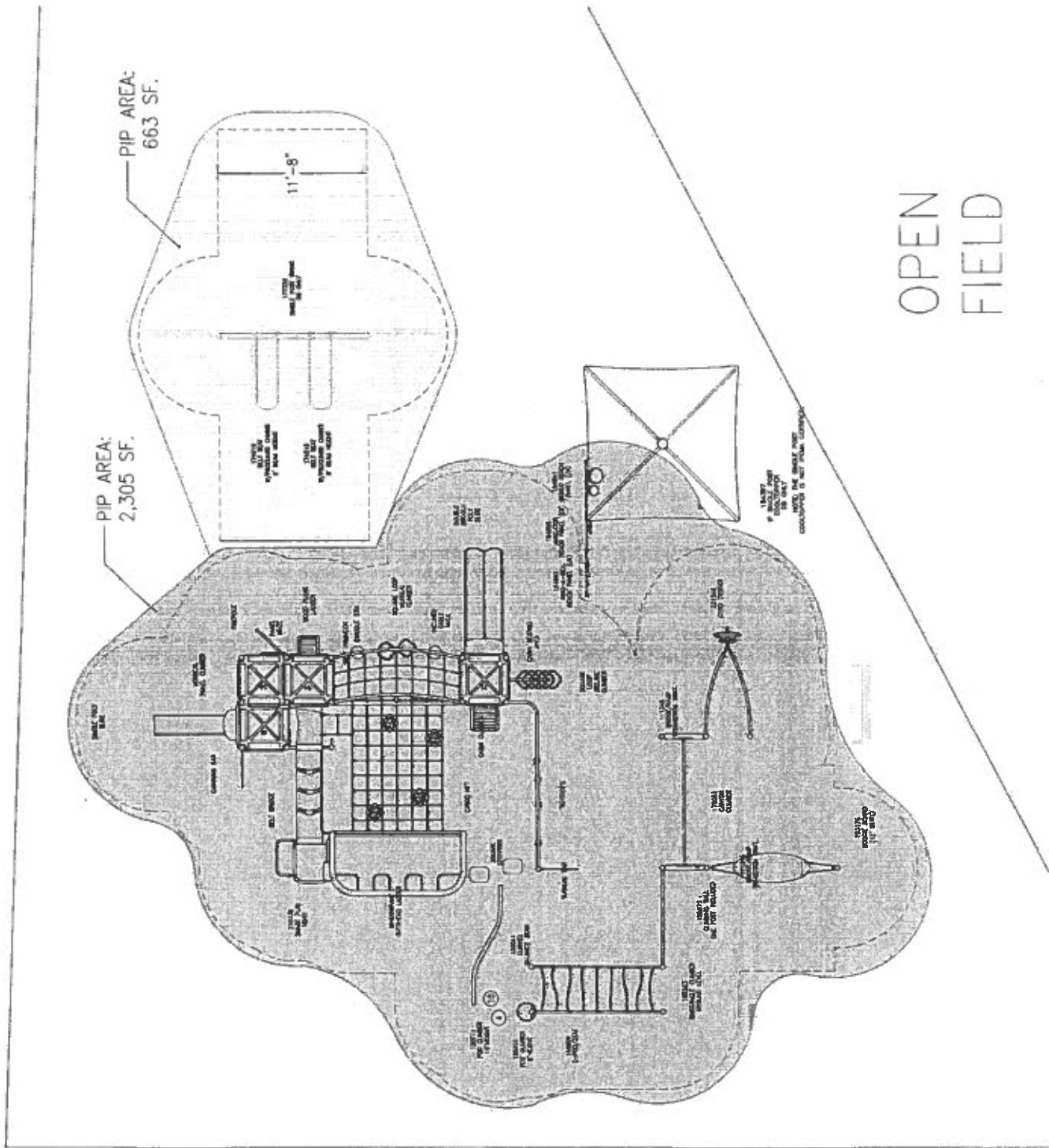

RECEIVED

JUL 28 2017

SCHOOL BUILDING

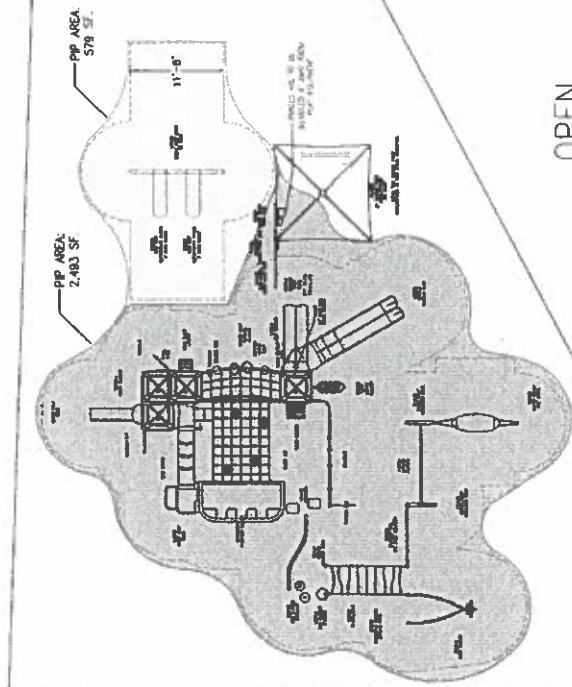

| | | | |
|--|----|----|----------|
| TOTAL ELEVATED PLAY COMPONENTS | 14 | 0 | REQUIRED |
| TOTAL ELEVATED COMPONENTS ACCESSIBLE BY RAMP | 8 | 0 | REQUIRED |
| TOTAL ELEVATED COMPONENTS ACCESSIBLE BY TRANSFER | 8 | 0 | REQUIRED |
| TOTAL DIFFERENT TYPES OF GROUND LEVEL COMPONENTS | 17 | 17 | REQUIRED |
| TOTAL DIFFERENT TYPES OF GROUND LEVEL COMPONENTS | 7 | 7 | REQUIRED |

DOUBLE SWOOSH SLIDE ON 72" DECK NOT BEING INSTALLED. NEW ADDITIONAL DECK, 4 POSTS, 96" SLIDE, PERM LAUDER & BARRIER.



The PlaySafe Certified logo is a mark of approval for playground equipment that meets the ASTM F1487 safety standard. It is a mark of approval for equipment that has been tested and certified by an independent third party.

THIS PLAY SET IS A SLIP RESISTANT SURFACE FOR AGE 5-12 YEARS UNLESS OTHERWISE NOTED ON PLAN.

IF IS THE MANUFACTURER'S OWNERS AND THE USER, ACCESSIBILITY STANDARDS, INCLUDING AN ACCESSIBLE ROUTING SURFACE, SHALL BE MAINTAINED WITHIN THE DESIGN USE ZONE.

THE CONTRACTOR SHALL BE RESPONSIBLE FOR OBTAINING ALL NECESSARY PERMITS AND APPROVALS FROM ALL APPLICABLE AGENCIES AND AUTHORITIES OF JURISDICTION. THE CONTRACTOR SHALL BE RESPONSIBLE FOR OBTAINING ALL NECESSARY PERMITS AND APPROVALS FROM ALL APPLICABLE AGENCIES AND AUTHORITIES OF JURISDICTION.

CHOICE OF MANUFACTURER, SPECIFICATIONS, MATERIALS, AND FINISHES SHALL BE THE RESPONSIBILITY OF THE CONTRACTOR. THE CONTRACTOR SHALL BE RESPONSIBLE FOR OBTAINING ALL NECESSARY PERMITS AND APPROVALS FROM ALL APPLICABLE AGENCIES AND AUTHORITIES OF JURISDICTION.

IT IS THE MANUFACTURER'S RESPONSIBILITY TO VERIFY THAT THE USER OF THESE COMPONENTS IS THE U.S. CONSUMER PRODUCT SAFETY COMMISSION (CPSC) MEMBER FOR PUBLIC FUNDATION SAFETY.

DESIGNED BY: J.R. [Name]

COMPANY: Ssa LANDSCAPE STRUCTURES, INC. 100 W. GREAT BRIDGE RD. SALEM, MA 01970-1100

| | | |
|------|----------------|----------|
| Date | Project Number | Revision |
| | | |



BENTLEY ACADEMY CHARTER SCHOOL
SALEM, MA

M.E. O'BRIEN & SONS, INC.
ANDY BERGER

SYSTEM TYPE: PB/EVOS/IND
DRAWING #: ME017257

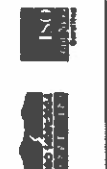

Bentley

RECEIVED

NOV 28 2017

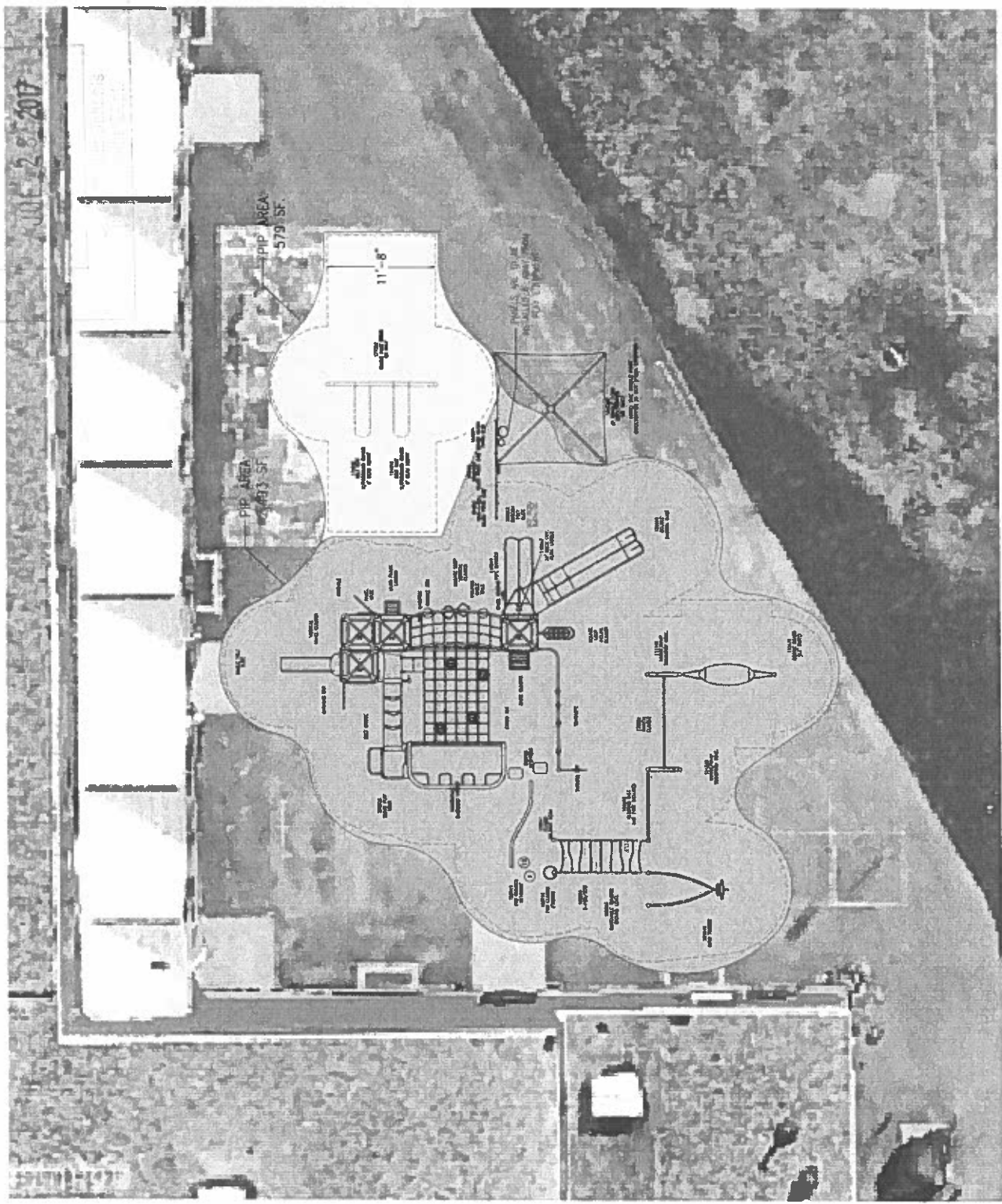

BONA

BENTLEY ACADEMY CHARTER SCHOOL

SALEM, WA April 12, 2017 1049554113



Slr
landscape
structures



Better playgrounds.
Better world.[®]
playisi.com

Proudly presented by:
ANDY BERGER



**O'BRIE
& SON**
ELEMENTS FOR A GREAT OUT!

BENTLEY ACADEMY CHARTER SCHOOL

SALEM, MA · April 12, 2017 · 104.955.1111

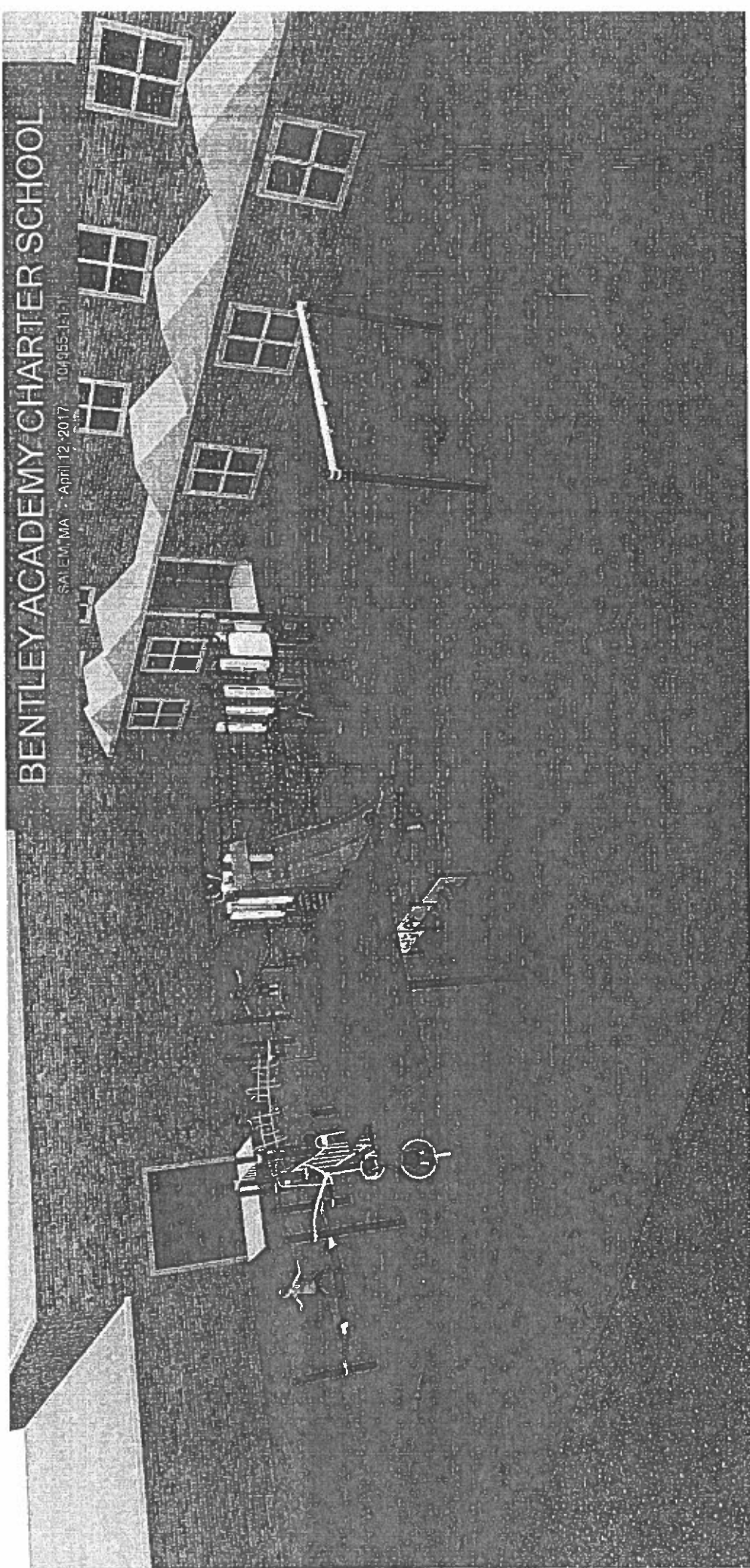

lan
landscape
structures



Better playgrounds.
Better world.®
playisi.com

Proudly presented by:
ANDY BERGER



O'BRIE & SON
ELEMENTS FOR A GREAT OUT!

BENTLEY ACADEMY CHARTER SCHOOL

SAITM, MA April 12, 2017 104955-1-12

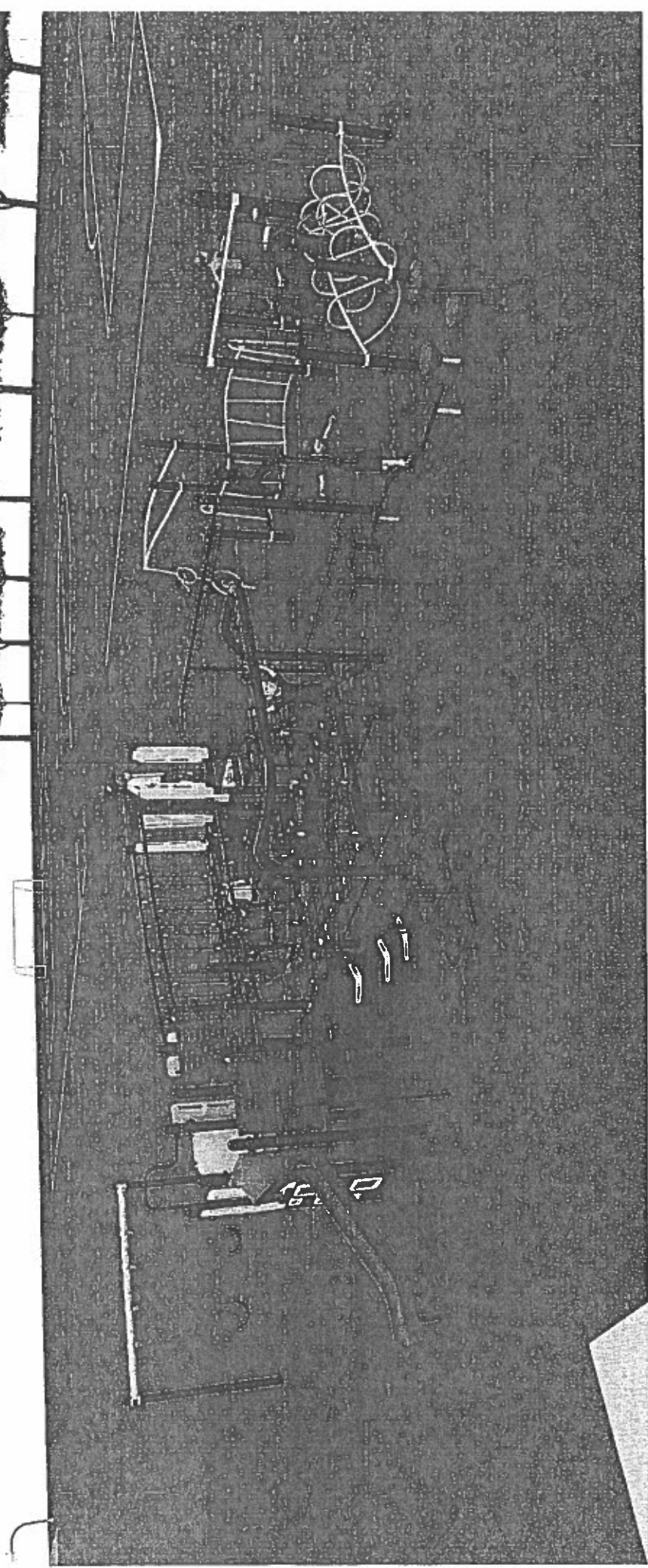

lan
landscape
structures



Better playgrounds.
Better world.®

playisi.com

Proudly presented by:
ANDY BERGER



O'BRIE & SON
ELEMENTS FOR A GREAT OUT!



The play components identified on this plan are designed to meet the ASTM F1487 safety standard. These components conform to the IPEMA product certification, with www.ipema.org

THIS PLAY AREA & PLAY EQUIPMENT IS DESIGNED TO MEET THE IPEMA STANDARD UNLESS OTHERWISE NOTED ON PLAN.

IT IS THE MANUFACTURER'S OPINION THAT THIS PLAY AREA IDEAS CONFORM TO THE ASTM F1487 SAFETY STANDARD. THE ADA ACCESSIBILITY REQUIREMENTS SURFACING IS PROVIDED, AS INDICATED, OR WITHIN THE ENTIRE USE ZONE.

THIS CONCEPTUAL PLAN WAS BASED ON THE MANUFACTURER'S CONSTRUCTION, RETAINED SITE INFORMATION INCLUDING EXISTING UTILITIES, SOIL CONDITIONS, AND DRAINAGE SOLUTIONS SHOULD BE OBTAINED, EVALUATED, & APPROVED PRIOR TO CONSTRUCTION. DIMENSIONS OF PLAY AREA, SIZE, ORIENTATION, AND LOCATION OF PLAY EQUIPMENT, UTILITIES, AND SITE FINISHING PRIOR TO INSTALLING SHOULD NOT FACE THE PLAY ATTENTION SUN.

CONCRETE FOUNDATION SHALL BE USED FOR ALL PLAY EQUIPMENT TO MEET THE MANUFACTURER'S RECOMMENDATIONS FOR FOUNDATION. THE EQUIPMENT SHALL BE INSTALLED ON A SURFACE OF PERFORATED POLYPROPYLENE PLAYGROUND EQUIPMENT FOR PUBLIC USE, SECTION 8 CURRENT EDITION. THE SOIL DOES NOT DRAIN NATURALLY IT MUST BE TILLED OR SLOPED 1/8" TO 1/4" PER FOOT TO A SLOPE TOWARD A DRAINAGE DITCH.

ACCESSIBLE/PROTECTIVE SURFACING TO BE A COMBINATION OF UNIFORM AND DOSE FILL MATERIALS.

IT IS THE MANUFACTURER'S OPINION AND INTENT THAT THE LAYOUT OF THESE COMPONENTS CONFORMS WITH THE CONSUMER PROTECTIVE SAFETY COMMISSION'S (CPSC) HANDBOOK FOR PUBLIC PLAYGROUND SAFETY.

DESIGNED BY:

JRA

LANDSCAPE STRUCTURES, INC.
601 7th STREET SOUTH, P.O. BOX 118
PH: 1-800-338-6035 FAX: 1-214-972-9891

Date Previous Drawing # Issues



STREET

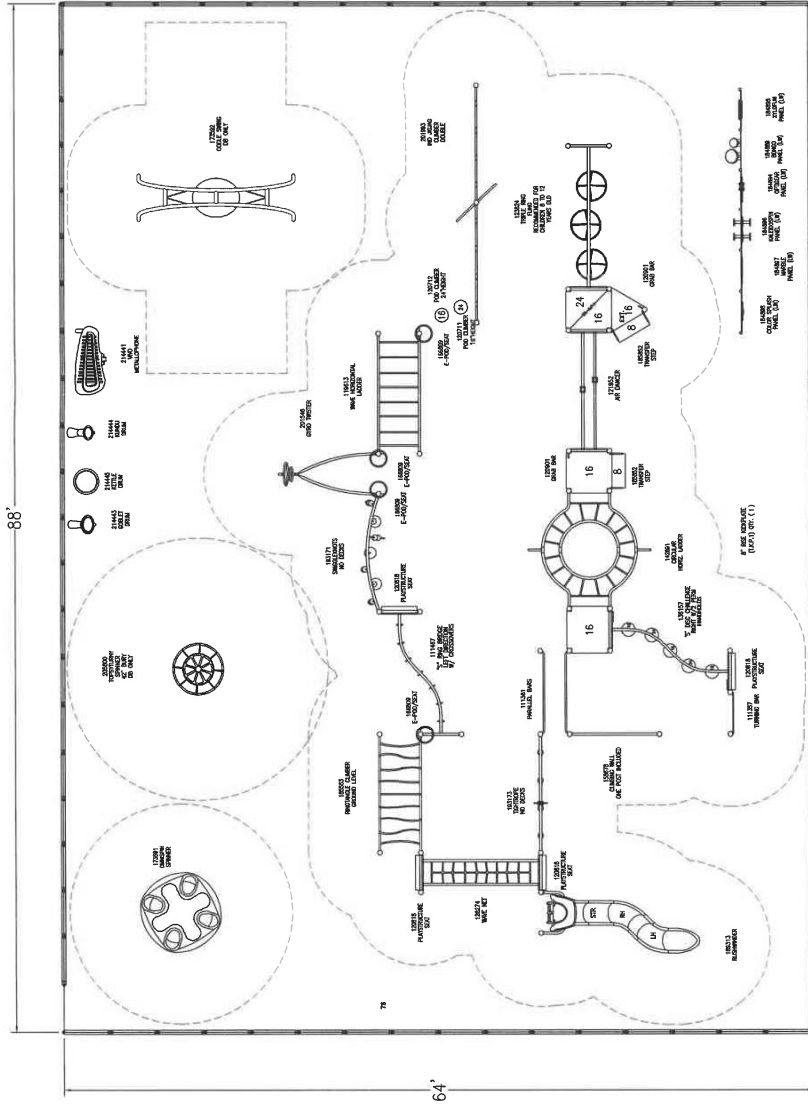

HILL

TOTAL ELEVATED PLAY COMPONENTS 4
 TOTAL ELEVATED COMPONENTS ACCESSIBLE BY RAMP 0
 TOTAL ELEVATED COMPONENTS ACCESSIBLE BY TRANSFER 2
 TOTAL ACCESSIBLE GROUND LEVEL COMPONENTS SHOWN 32
 TOTAL DIFFERENT TYPES OF GROUND LEVEL COMPONENTS 9



80 West Street
 Methuen, MA 02842-0000
 Phone: 978-352-2100
 Fax: 978-352-2817

SALTONSTALL SCHOOL
 SALEM, MA

M.E. O'BRIEN &
 SONS, INC.
 ANDY BERGER

SYSTEM TYPE:
 PLAYBOOSTER/IND
 DRAWING #:
 MEC017456

EMC Plans

21
368
30
3068

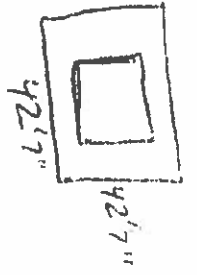
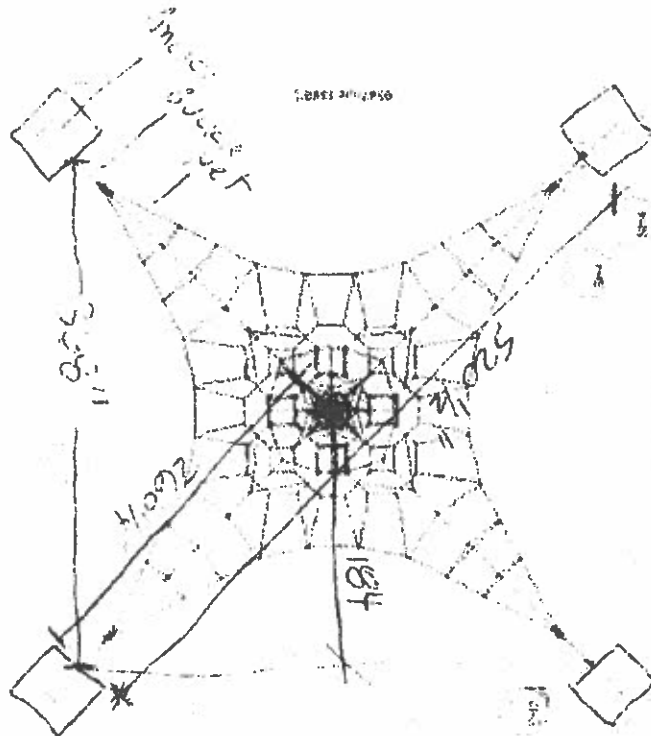

Witchcraft

310

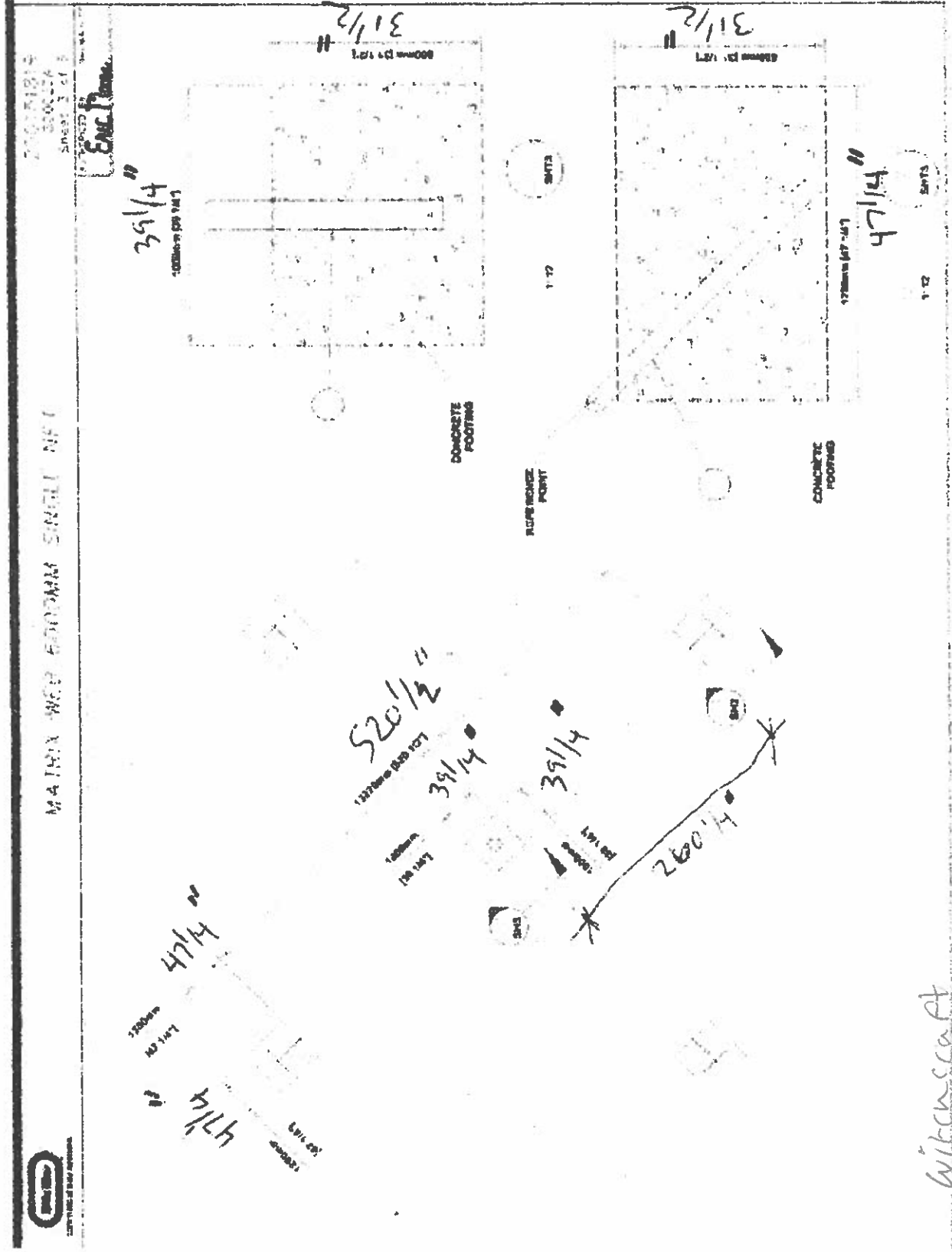

Witchcraft

300-11110
300-11111
300-11112

MAIRIX AND PROGRAM SINGLE NOY



EXIST. FOUNDATION

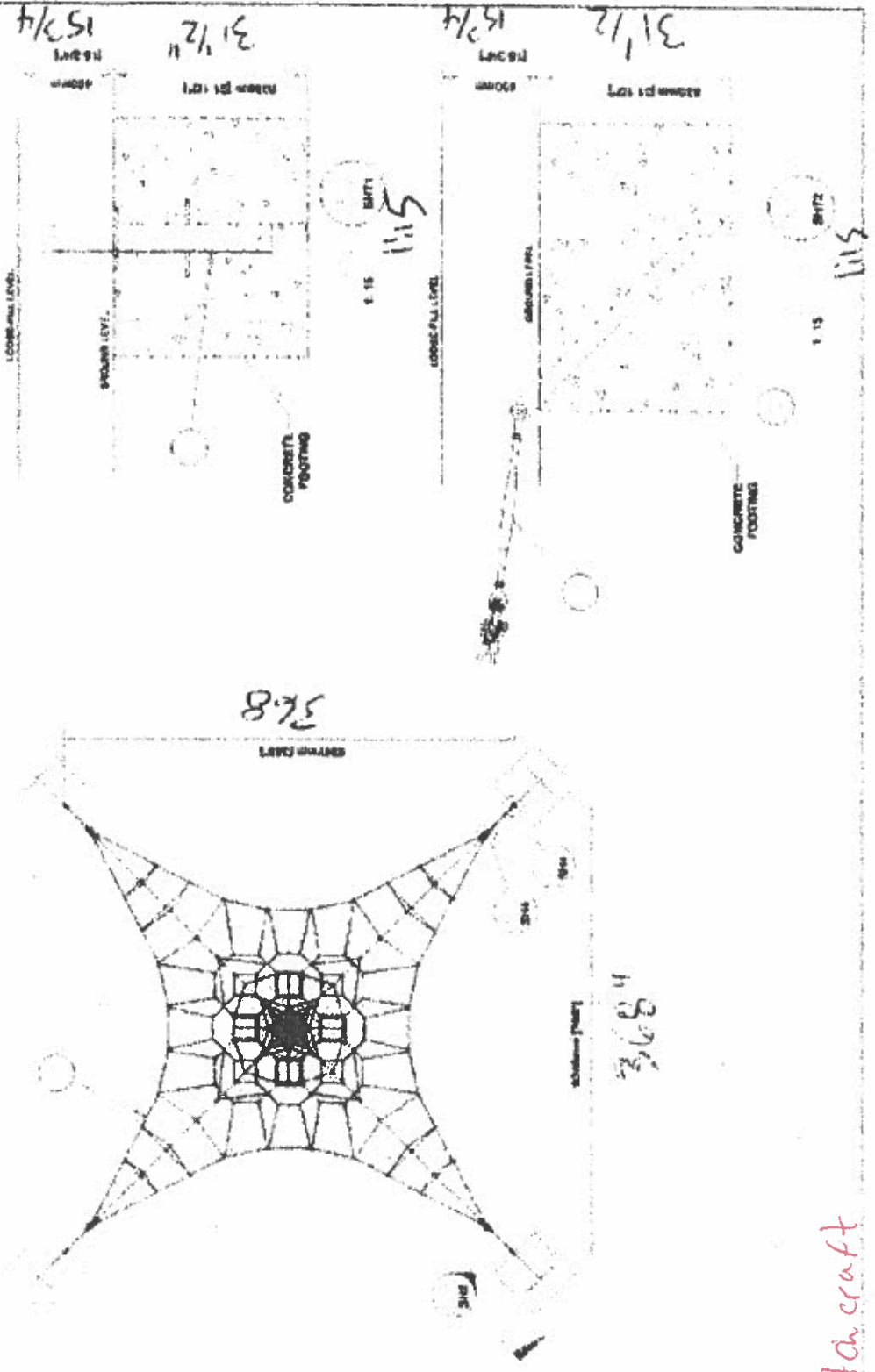

W.A. Craft

2022 Playground Study Report

Prepared for the City of Salem Public Schools, in Massachusetts

C. MAAB Regulations + Access Board ADA Guides for Play Areas

MASSACHUSETTS ARCHITECTURAL ACCESS BOARD (MAAB)

* CMR 521

* STILL EVOLVING

*PUBLIC MEETINGS HELD IN 2018

*UNDERSTAFFED TO ENFORCE.

* NO "GRAND-FATHERING" IN.

ENORMOUS FINANCIAL IMPLICATIONS FOR
ALL GOVERNMENTAL ENTITIES

* IF COMPLAINT IS MADE WITH
MAAB, MUNICIPAL ENTITY WILL BE PLACED
ON NOTICE TO RECTIFY OTHERWISE FINED.

*** NOTE ENTIRE SECTION IS RED LINED
IDENTIFYING THAT ENTIRE CMR 521 FOR
PLAYGROUNDS WILL BE CHANGING.**

~~19.759.00: PLAYGROUNDS-PLAY AREAS~~

~~An accessible route, complying with 521-CMR-208.00: ACCESSIBLE ROUTE shall be provided to reach playground equipment and around the playground.~~

59.1 GENERAL

Play areas for children ages 2 and over shall comply with the following requirements.

Exceptions:

1. *Play areas* located in family child care facilities where the proprietor actually resides.
2. In existing *play areas*, where *play components* are relocated for the purposes of creating safe use zones and the ground surface is not altered or extended for more than one (1) *use zone*.

3. *Amusement attractions*; however they shall comply with the requirements of **521 CMR 48.00: AMUSEMENT RIDES**.

59.2 NUMBER AND TYPES

Ground Level Play Components or Elevated Play Components: Where provided, at least one (1) of each type shall be on an *accessible route* and shall comply with **521 CMR 59.3, Location**.

- 59.2.1 Where *elevated play components* are provided, *ground level play components* shall be provided in accordance with **Table 59.2**. Where two (2) or more required *ground level play components* or *elevated play components* are provided, per **Table 59.2**, they shall be dispersed throughout the *play area* and integrated with other *play components*.

Exception:

If at least 50 percent of the *elevated play components* are connected by a *ramp* and at least three (3) of the *elevated play components* connected by the *ramp* are different types of *play components*, the *play area* shall not be required to comply with **521 CMR 59.2.1**.

| Table 59.2 Number and Types of Ground Level Play Components Required to be on Accessible Routes | | |
|--|--|---|
| Number of <i>Elevated Play Components</i> Provided | Minimum Number of <i>Ground Level Play Components</i> Required to be on an <i>Accessible Route</i> | Minimum Number of Different Types of <i>Ground Level Play Components</i> Required to be on an <i>Accessible Route</i> |
| 1 | Not applicable | Not applicable |
| 2 to 4 | 1 | 1 |
| 5 to 7 | 2 | 2 |
| 8 to 10 | 3 | 3 |
| 11 to 13 | 4 | 3 |
| 14 to 16 | 5 | 3 |
| 17 to 19 | 6 | 3 |
| 20 to 22 | 7 | 4 |
| 23 to 25 | 8 | 4 |
| 26 and over | 8, plus 1 for each additional 3, or fraction thereof, over 25 | 5 |

59.3 LOCATION

Where separate *play areas* are provided within a *site* for specific age groups (e.g., preschool (ages 2 to 5) and school age (ages 5 to 12)), each *play area* shall independently comply with the requirements of **521 CMR 59.00: PLAY AREAS**. Where *play areas* are provided for the same age group on a *site* but are geographically separated (e.g., one is located next to a picnic area and another is located next to a softball field), they are considered separate *play areas* and each *play area* must comply with this section.

59.4 ACCESSIBLE ROUTES

An *accessible route* shall be provided to reach playground equipment and around the *perimeter* of the playground for the following *play components*:

- a. *Ground Level Play Components and Elevated Play Components*: At least one (1) *accessible route* shall be provided within the *play area*. The *accessible route* shall connect *ground level play components* and *elevated play components* required to comply with **521 CMR 59.2, Number and Types**, including entry and exit points of the *play components*.
Exceptions:
 - 1. Transfer systems complying with **521 CMR 59.5, Transfer Systems**, shall be permitted to connect *elevated play components*, except where 20 or more *elevated play components* are provided no more than 25 percent of the *elevated play components* shall be permitted to be connected by transfer systems.
 - 2. Where transfer systems are provided, an *elevated play component* shall be permitted to connect another *elevated play component* as part of an *accessible route*.
- b. *Soft Contained Play Structures*: Where three (3) or fewer entry points are provided for *soft contained play structures*, at least one (1) entry point shall be on an *accessible route*. Where four (4) or more entry points are provided for *soft contained play structures*, at least two (2) entry points shall be on an *accessible route*.
Exception:
Transfer systems complying with **521 CMR 59.5, Transfer Systems** shall be permitted to be used as part of an *accessible route*.
- c. *Water Play Components*: Where the surface of the *accessible route, clear floor or ground spaces*, or turning spaces serving *water play components* is submerged, it shall comply with **521 CMR 54.8, Sloped Entries**. Transfer systems complying with **521 CMR 59.5, Transfer Systems**, shall be permitted to connect *elevated play components* in water.

59.4.1 The ground surface of *use zones, accessible routes* and turning spaces within *play areas* shall be firm, stable and slip resistant, permanent, and constructed of materials such as rubber resilient surfacing, urethane rubber composites or similar; and comply with commonly accepted impact attenuation criteria for safety surfacing materials within the *use zones* of *play area* equipment. Loose fill surfaces and aggregate surfaces including wood fiber, bark mulch, wood chips, shredded rubber, shredded foam, etc. are not acceptable for *accessible routes* within the playground. Molded rubber mats, if utilized, require adhesion to a permanent surface beneath.

59.4.2 The *clear width* of *accessible routes* to *play components* shall comply with the following:

- a. At ground level, the *clear width* of *accessible routes* shall be 60 inches (1524 mm) minimum.
Exceptions:
 - 1. In *play areas* less than 1000 square feet (93 m²), the *clear width* of *accessible routes* shall be permitted to be 44 inches (1118 mm) minimum, if at least one (1) turning space complying with **521 CMR 6.2, Wheelchair Turning Space** is provided where the restricted *accessible route* exceeds 30 feet (9144 mm) in length.
 - 2. The *clear width* of *accessible routes* shall be permitted to be 36 inches (914 mm) minimum for a distance of 60 inches (1524 mm) maximum provided that multiple reduced width segments are separated by segments that are 60 inches (1524 mm) wide minimum and 60 inches (1524 mm) long minimum.

59.4.3 The *clear width* of *accessible routes* connecting *elevated play components* shall be 36 inches (914 mm) minimum.

Exceptions:

1. The *clear* width of *accessible routes* connecting *elevated play components* shall be permitted to be reduced to 32 inches (813 mm) minimum for a distance of 24 inches (610 mm) maximum provided that reduced width segments are separated by segments that are 48 inches (1219 mm) long minimum and 36 inches (914 mm) wide minimum.
2. The *clear* width of transfer systems connecting *elevated play components* shall be permitted to be 24 inches (610 mm) minimum.

59.4.4 Where *play components* require transfer to entry points or seats, the entry points or seats shall be 11 inches (280 mm) minimum and 24 inches (610 mm) maximum from the *clear floor or ground space*. Where *play components* require transfer to entry points or seats, at least one (1) means of support for transferring shall be provided per **521 CMR 59.6.3**.

Exception:

Entry points of slides shall not be required to comply with the requirements of **521 CMR 59.5.2, Entry Points and Seats**.

59.4.5 At least one (1) turning space complying with **521 CMR 6.2, Wheelchair Turning Space**, shall be provided on the same level as *play components*. Where swings are provided, the turning space shall be located immediately adjacent to the swing.

59.4.6 *Clear floor or ground space* complying with **521 CMR 6.1, Clear Floor or Ground Space for Wheelchairs** shall be provided at *play components*. *Clear floor or ground spaces*, turning spaces, and *accessible routes* are permitted to overlap within *play areas*.

59.4.7 Within *play areas*, *ramps* connecting *ground level play components* and *ramps* connecting *elevated play components* shall comply with the following:

- a. *Ramp* runs connecting *ground level play components* shall have a *running slope* not steeper than 1:16.
- b. The rise for any *ramp* run connecting *elevated play components* shall be 12 inches (305 mm) maximum.

59.4.8 Where required on *ramps* serving *play components*, the handrails shall comply with the following:

Exceptions:

1. Handrails shall not be required on *ramps* located within *ground level use zones*.
2. Handrail extensions shall not be required.
 - a. Handrail gripping surfaces with a circular cross section shall have an outside diameter of 0.95 inch (24 mm) minimum and 1.55 inches (39 mm) maximum. Where the shape of the gripping surface is non-circular, the handrail shall provide an equivalent gripping surface.
 - b. The top of handrail gripping surfaces shall be 20 inches (508 mm) minimum and 28 inches (711 mm) maximum above the *ramp* surface.

59.5 TRANSFER SYSTEMS

Where transfer systems are provided, consideration should be given to the distance between the transfer system and the *elevated play components*. Moving between a transfer platform and a series of transfer steps requires extensive exertion for some children. Designers should minimize the distance between the points where a child transfers from a wheelchair or mobility device and where the *elevated play components* are located. Where *elevated play components* are used to connect to another *elevated play*

component instead of an *accessible route*, careful consideration should be used in the selection of the *play components* used for this purpose.

- 59.5.1 Transfer platforms shall be provided where transfer is intended from wheelchairs or other mobility aids. Transfer platforms shall comply with the following (See **Figure 59.5a**):
- Transfer platforms shall have *level surfaces* 14 inches (356 mm) deep minimum and 24 inches (610 mm) wide minimum.
 - The height of transfer platforms shall be 11 inches (280 mm) minimum and 18 inches (457 mm) maximum measured to the top of the surface from the ground or floor surface.

Figure 59.5a

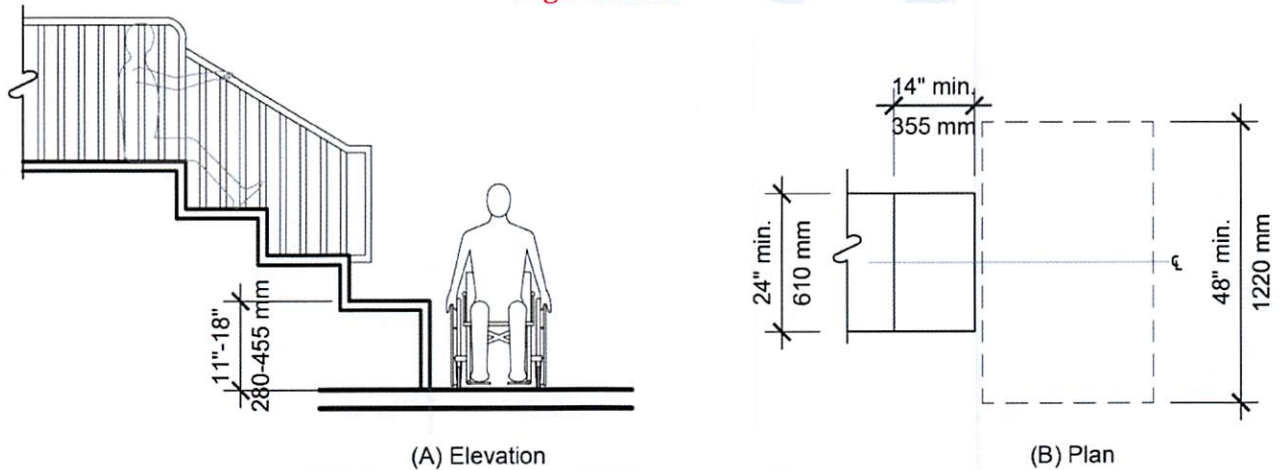

- 59.5.2 A transfer space complying with **521 CMR 6.1, Clear Floor or Ground Space for Wheelchairs**, shall be provided adjacent to the transfer platform. The 48 inch (1219 mm) long minimum dimension of the transfer space shall be centered on and parallel to the 24 inch (610 mm) long minimum side of the transfer platform. The side of the transfer platform serving the transfer space shall be unobstructed.
- 59.5.3 At least one (1) means of support for transferring shall be provided. Transfer supports are required on transfer platforms and transfer steps to assist children when transferring. Some examples of supports include a rope loop, a loop type handle, a slot in the edge of a flat horizontal or vertical member, poles or bars, or D rings on the corner posts.
- 59.5.4 Transfer steps shall be provided where movement is intended from transfer platforms to levels with *elevated play components* required to be on *accessible routes*. Transfer steps shall comply with the following (See **Figure 59.5b**):
- Transfer steps shall have *level surfaces* 14 inches (356 mm) deep minimum and 24 inches (610 mm) wide minimum.
 - Each transfer step shall be 8 inches (203 mm) high maximum.

Figure 59.5a

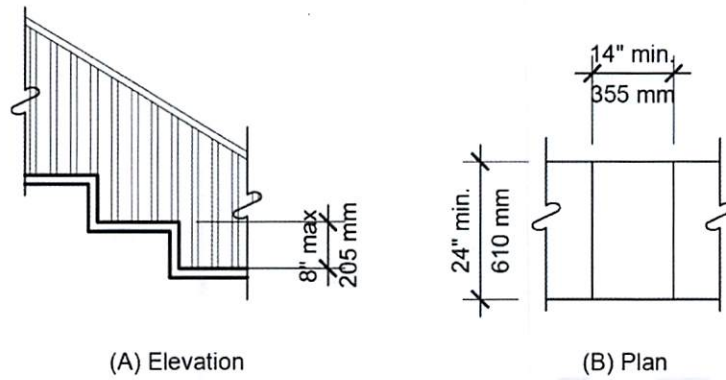

59.6 PLAY TABLES

Where play tables are provided, knee clearance 24 inches (610 mm) high minimum, 17 inches deep (432 mm) minimum, and 30 inches (762 mm) wide minimum shall be provided. The tops of rims, curbs, or other obstructions shall be 31 inches (787 mm) high maximum.

Exception:

Play tables designed and constructed primarily for children five (5) years and younger shall not be required to provide knee clearance where the *clear floor or ground space* required by **521 CMR 59.5.4, Clear Floor or Ground Space** is arranged for a parallel approach.

ACCESSIBLE PLAY AREAS

A Summary of Accessibility Guidelines for Play Areas



U.S. Access Board
Summary of Accessibility Guidelines
for Play Areas

The Americans with Disabilities Act (ADA) is a comprehensive civil rights law that prohibits discrimination on the basis of disability. The ADA requires that newly constructed and altered State and local government facilities, places of public accommodation, and commercial facilities be readily accessible to, and usable by, individuals with disabilities. Recreational facilities, including play areas, are among the facilities required to comply with the ADA.

The Architectural and Transportation Barriers Compliance Board - often referred to as the "Access Board" - has developed accessibility guidelines for newly constructed and altered play areas. The play area guidelines are a supplement to the Americans with Disabilities Act Accessibility Guidelines (ADAAG). Once these guidelines are adopted as enforceable standards by the Department of Justice, all newly constructed and altered play areas covered by the ADA will be required to comply. These guidelines also apply to play areas covered by the Architectural Barriers Act (ABA).

Summary

This guide is intended to help designers and operators in using the accessibility guidelines for play areas. These guidelines establish minimum accessibility requirements for newly constructed and altered play areas. This guide is not a collection of playground designs. Rather, it provides specifications for elements within a play area to create a general level of usability for children with disabilities. Emphasis is placed on ensuring that children with disabilities are generally able to access the diversity of components provided in a play area. Designers and operators are encouraged to exceed the guidelines where possible to provide increased accessibility and opportunities. Incorporating accessibility into the design of a play area should begin early in the planning process with consideration to layout, circulation paths, and the selection of play components.

The play area guidelines were developed with significant public input and carefully considered the balancing of costs, safety, and accessibility. The Access Board sponsored a Regulatory Negotiation Committee to develop proposed guidelines. The public was given an opportunity to comment on the proposed guidelines and the Access Board made changes to the proposed guidelines based on the public comments. The Regulatory Negotiation Committee represented the following groups and associations:

| | |
|--|--|
| American Society of Landscape Architects | National Easter Seal Society |
| ASTM Public Playground Committee | National League of Cities |
| ASTM Soft Contained Play Committee | National Parent-Teacher Association |
| ASTM Playground Surfacing Systems Committee | National Recreation and Park Association |
| International Play Equipment Manufacturers Association | Spina Bifida Association of America |
| National Association of Counties | TASH |
| National Association of Elementary School Principals | United Cerebral Palsy Association |
| National Child Care Association | U.S. Access Board |
| National Council on Independent Living | |

This guide is designed to assist in using the play area accessibility guidelines and is divided into the following sections:

- Where Do the Play Area Guidelines Apply?
- What is a Play Component?
- How Many Play Components Must Be on an Accessible Route?
- What Are the Requirements for Accessible Routes?
- What Other Accessibility Requirements Apply to Play Components?
- Soft Contained Play Structures

Copies of the play area accessibility guidelines and further technical assistance can be obtained from the U.S. Access Board, 1331 F Street, Suite 1000 NW, Washington, DC 20004-1111; 800-872-2253, 800-993-2822 (TTY); www.access-board.gov. Alternate formats of this document are also available upon request.

October 2005



| | |
|--|--------------|
| Play Area Terms | 4-5 |
| <hr/> | |
| Where Do the Play Area Guidelines Apply? | 6-8 |
| <hr/> | |
| New Construction | 6 |
| Alterations..... | 6 |
| Equivalent Facilitation..... | 6 |
| Phasing in Play Areas | 7 |
| Play Areas Separated By Age..... | 8 |
| Geographically Separated Play Areas..... | 8 |
| What is a Play Component? | 9-13 |
| <hr/> | |
| Play Components..... | 9 |
| Different “Types”..... | 10-11 |
| Elevated Play Components..... | 12 |
| Ground-Level Play Components..... | 13 |
| How Many Play Components Must Be On An Accessible Route? | 14-18 |
| <hr/> | |
| Ground Level Play Components - One of Each Type..... | 14 |
| Ground Level Requirements - Based on Elevated Play Components ... | 15 |
| Elevated Play Components..... | 16 |
| Step-by-Step Guide | 17 |
| <hr/> | |
| Play Area Evaluation Example | 18 |
| <hr/> | |
| What Are the Requirements For Accessible Routes? | 19-32 |
| <hr/> | |
| Accessible Routes..... | 19 |
| Ground-Level Accessible Routes | 20-21 |
| Accessible Ground Surfaces..... | 22 |
| Accessible Surfaces Located in the Use Zone..... | 22-23 |
| Elevated Accessible Routes..... | 24 |
| When Ramps Are Required..... | 25-27 |
| When Transfer Systems Are Used..... | 28-31 |
| Connected Elevated Components..... | 32 |
| What Other Accessibility Requirements Apply to Play Components? | 33-37 |
| <hr/> | |
| Clear Floor or Ground Space..... | 33 |
| Maneuvering Space..... | 34 |
| Entry Points and Seats..... | 35 |
| Play Tables..... | 36 |
| Reach Ranges (Advisory)..... | 37 |
| Soft Contained Play Structures | 38 |
| <hr/> | |
| Alterations | 39 |
| <hr/> | |
| Acknowledgements | 40 |
| <hr/> | |



Play Area Terms

Many terms are used throughout this guide to describe the play area guidelines. Familiarity with these terms is important when applying the guidelines. Other definitions are provided in ADA/ABA.

ABA - Architectural Barriers Act

Access Board – An independent Federal agency that develops accessibility guidelines under the ADA and other laws. The Access Board is also known as the Architectural and Transportation Barriers Compliance Board.

Accessible – Describes a site, building, facility, or portion thereof that complies with the play area guidelines.

Accessible Route – A continuous unobstructed path connecting all accessible elements and spaces of a building or facility. Inside the boundary of the play area, accessible routes may include platforms, ramps, elevators, lifts. Outside the boundary of the play area, accessible routes may also include parking access aisles, curb ramps, crosswalks at vehicular ways, walks, ramps, and lifts.

ADA – Americans with Disabilities Act.

Alteration – An alteration is a change to a building or facility that affects or could affect the usability of the building or facility or part thereof. Alterations include, but are not limited to, remodeling, renovation, rehabilitation, reconstruction, historic restoration, resurfacing of circulation paths or vehicular ways, changes or rearrangement of structural parts or elements, and changes or rearrangement in the plan configuration of walls and full-height partitions. Normal maintenance is not an alteration unless it affects the usability of the facility (*see section on alterations for more details*).

Amusement Attraction – Any facility, or portion of a facility, located within an amusement park or theme park, that provides amusement without the use of an amusement device. Examples include, but are not limited to, fun houses, barrels, and other attractions without seats.

ASTM – American Society for Testing and Materials.

Berm – A sloped surface at ground level designed to ascend or descend in elevation.

Clear – Unobstructed.

Composite Play Structure – Two or more play structures attached or functionally linked, to create one integral unit that provides more than one play activity (*ASTM F 1487-01*).

Cross Slope – The slope that is perpendicular to the direction of travel (*see running slope*).

Elevated Play Component – A play component that is approached above or below grade and that is part of a composite play structure consisting of two or more play components attached or functionally linked to create an integrated unit providing more than one play activity.



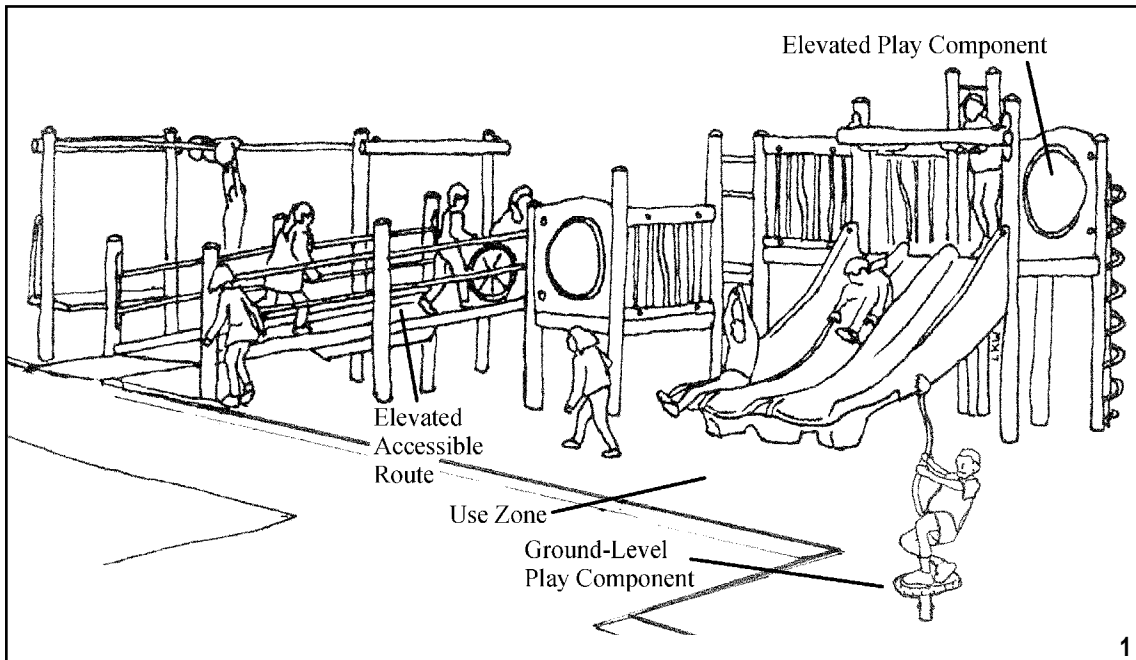

Facility – All or any portion of buildings, structures, site improvements, elements and pedestrian routes or vehicle ways located on a site.

Ground Level Play Component – A play component that is approached and exited at the ground level.

Play Area – A portion of a site containing play components designed and constructed for children.

Play Component – An element intended to generate specific opportunities for play, socialization, or learning. Play components may be manufactured or natural, and may be stand alone or part of a composite play structure.

Ramp – A walking surface that has a running slope of greater than 1:20.

Running Slope – The slope that is parallel to the direction of travel (*see cross slope*).

Site – A parcel of land bounded by a property line or a designated portion of a public right-of-way.

Soft Contained Play Structure – A play structure made up of one or more components where the user enters a fully enclosed play environment that utilizes pliable materials (e.g., plastic, netting, fabric).

Use Zone – The ground level area beneath and immediately adjacent to a play structure or piece of equipment that is designated by ASTM F 1487 Standard Consumer Safety Performance Specification for Playground Equipment for Public Use for unrestricted circulation. This is the play surface upon which it is predicted a user would land when falling from or exiting the equipment.



New Construction

The play area guidelines in this guide apply to all newly designed or constructed play areas for children ages 2 and older.

This includes play areas located in a variety of settings: parks, schools, childcare facilities, shopping centers, and public gathering areas. Owners or operators of newly constructed play areas are responsible for complying with these guidelines.

The play area guidelines do not apply to:

- Family childcare facilities where the proprietor resides
- Amusement attractions
- Religious entities



This large play area designed for the same age group is part of a public park system. The total of all the play components in this play area - which includes multiple composite structures - must be counted when applying the play area guidelines.

Alterations

The play area guidelines also apply to existing play areas where alterations occur. Further information regarding the application of the play area guidelines to altered play areas can be found on page 39.

Equivalent Facilitation

Designs that result in products or technologies as alternatives to those prescribed, provided substantially equivalent or greater accessibility and usability.

Equivalent facilitation is the concept of utilizing innovative solutions and new technology, design, or materials in order to satisfy the guidelines. These alternative solutions provide equal access and take advantage of new developments, but may differ technically from specific guidelines.

Phasing in Play Areas

When play areas are constructed in phases, they must continue to meet the play area guidelines throughout construction. The initial phase area must meet the guidelines, and then at each successive phase the whole play area must be reassessed to assure compliance.

“Phased designs” are play areas developed to be installed in different stages, allowing the play area to grow in a planned manner while accommodating budgets, fund raising, or community approval processes.

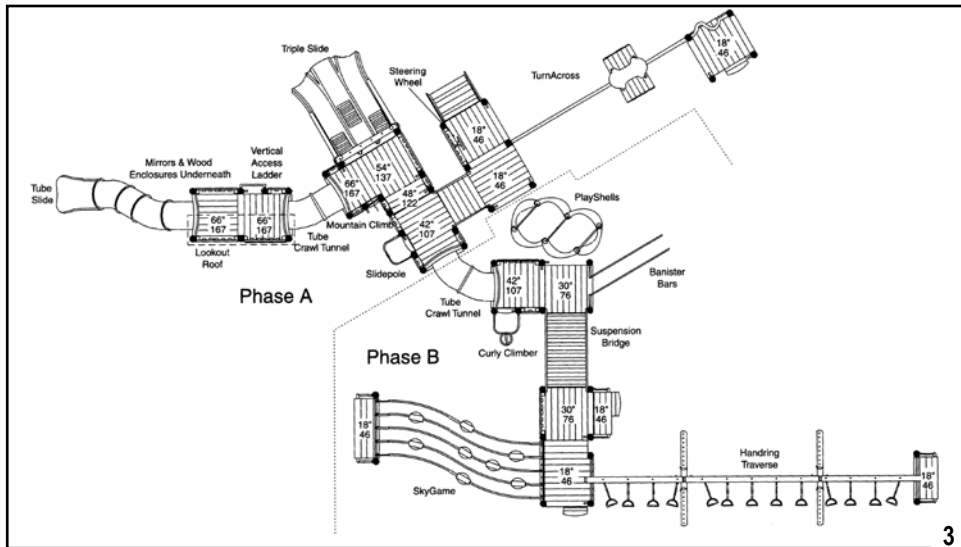

This play area will be installed in two phases. As each phase is completed, the entire play area must be reevaluated for compliance.

Prior to phase one, the first structure is evaluated for compliance, since the guidelines are based on a minimum number of play components required to be on an accessible route.

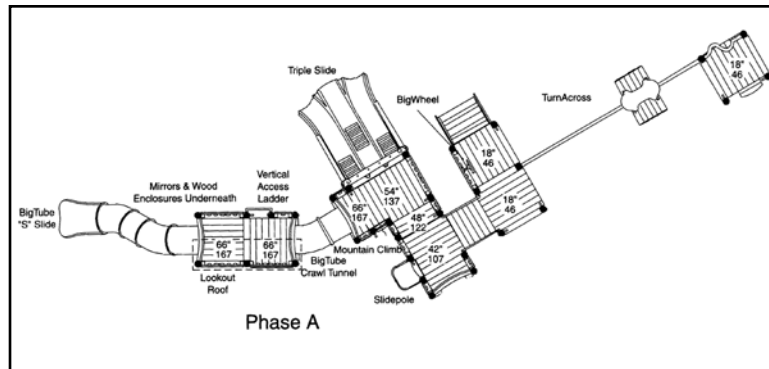

At the onset of phase two, the play area is reevaluated in its entirety.

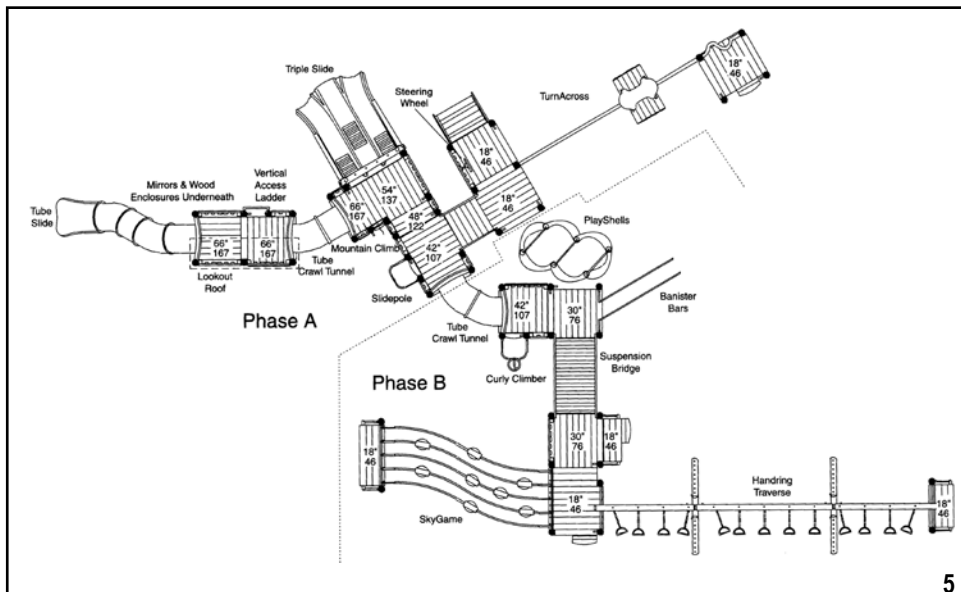

Play Areas Separated by Age

To reduce the risk of injury, safety guidelines recommend separate play areas for different age groups. In applying the guidelines, play areas designed for different age groups should be considered separately.

A play area designed for 2 to 5 year-olds is considered separate from one for 5 to 12 year-olds. Therefore, compliance with the guidelines must be considered for each individual play area.



This dual play area designed for 2 to 5 year-olds and 5 to 12 year-olds shares resilient surfacing. Each section must be evaluated separately.

Geographically Separated Play Areas

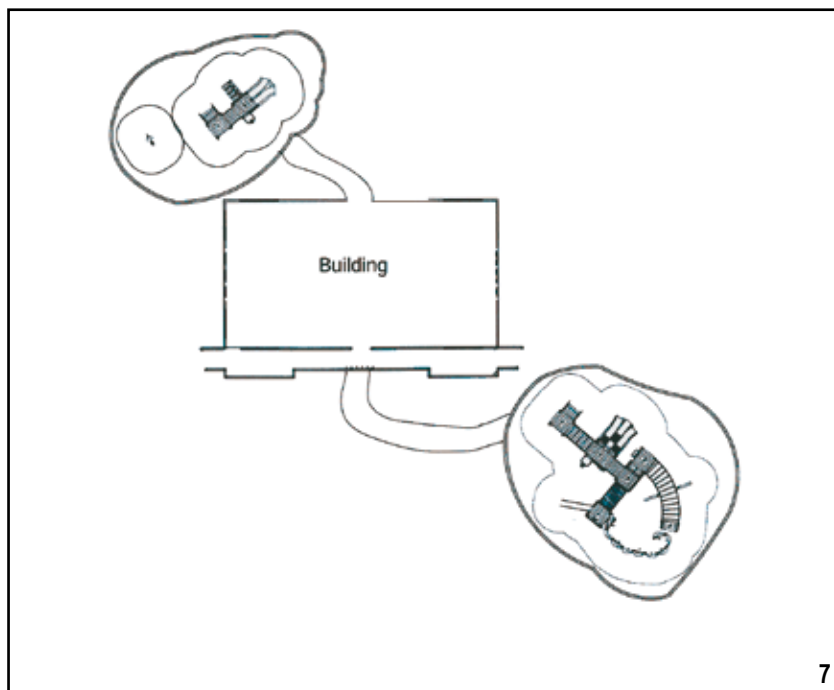

Large geographical spaces may contain several play areas within one park setting. Where play areas are geographically separated on a site, they are considered separate play areas. The accessibility guidelines apply to each play area.



Play Components

A play component is an element designed to generate specific opportunities for play, socialization, and learning. Play components may be manufactured or natural, and may be stand alone or part of a composite play structure. Swings, spring riders, water tables, playhouses, slides, and climbers are among the many different play components.

For the purpose of these guidelines, ramps, transfer systems, steps, decks, and roofs are not considered play components. These elements are generally used to link other elements on a composite play structure. Although socialization and pretend play can occur on these elements, they are not primarily intended for play.



Spring rider



Climber



Swing



Slide



WHERE DO THE PLAY AREA GUIDELINES APPLY?

When applying the play area guidelines, it is important to identify the different play experiences play components can provide.

Different “Types”

At least one of each type of play component provided at ground level in a play area must be on an accessible route.

Different “types” of play components are based on the general experience provided by the play component. Different types include, but are not limited to, experiences such as rocking, swinging, climbing, spinning, and sliding.

“Rocking” is an example of horizontal movement that can be backwards, forwards, sideways or even circular in nature.

“Sliding” is an example of rapid descent that utilizes the force of gravity.



A Swinging Type



A Rocking Type



This single play component provides one type of play experience for multiple individuals.



WHAT IS A PLAY COMPONENT?

The number of individuals who can play on a play component at once does not determine the quantity of play components provided in a play area. A play component can hold many children but is considered one type of play experience - or one play component - in the play area.



Examples of Sliding Types

While a spiral slide provides a slightly different experience from a straight slide, the primary experience - a sense of rapid descent or sliding - is common to both activities. Therefore, a spiral slide and a straight slide are considered one “type” of play experience.



WHAT IS A PLAY COMPONENT?

Elevated Play Components

An elevated play component is a play component that is approached above or below grade and is part of a composite play structure. Play components that are attached to a composite play structure and that can be approached from a platform or deck area are considered elevated play components.



This climber is considered an elevated component, since it can be approached or exited from the ground level or above grade from a platform or deck on a composite play structure.



Ground-Level Play Components

Ground-level play components are items that can be approached and exited at ground level. For example, a child approaches a spring rider at ground level via the accessible route. The child may ride then exit directly back onto the accessible route. The activity is considered ground level because the child approaches and exits it from the ground-level route.



Ground-level play components may be part of a composite structure.



Ground-level components may also be free-standing in a play area.

When more than one ground-level play component is required on an accessible route, the play components must be integrated. Designers should consider the optimal layout of ground-level play components to foster interaction and socialization among all children. Grouping all ground-level play components accessed by children with disabilities in one location does not constitute integration.

“Ground-level components” are approached and exited at ground level.

Ground-level play components may include items such as swings, spring riders, and panels.

Freestanding slides are considered ground-level components for the purpose of these guidelines. An accessible route must connect to the ladder or steps, and to the exit of the slide. While this solution does not provide access for all children, it gives many individuals the opportunity to access play components.



U.S. Access Board
Summary of Accessibility
Guidelines for Play Areas

Ground-Level Play Components

There are two requirements addressing how many ground-level play components must be on an accessible route:

- One of Each Type
- Ground-Level Requirements based on the number of Elevated Play Components

One of Each Type

At least one of each type of ground-level play component that is present in the play area must be on an accessible route.

As an example, this play area includes a composite play structure, two spring riders and a swing set (see inset). To meet the requirement, an accessible route must connect to at least one spring rider and one swing for one of each type of ground-level play experiences which are present in the play area.

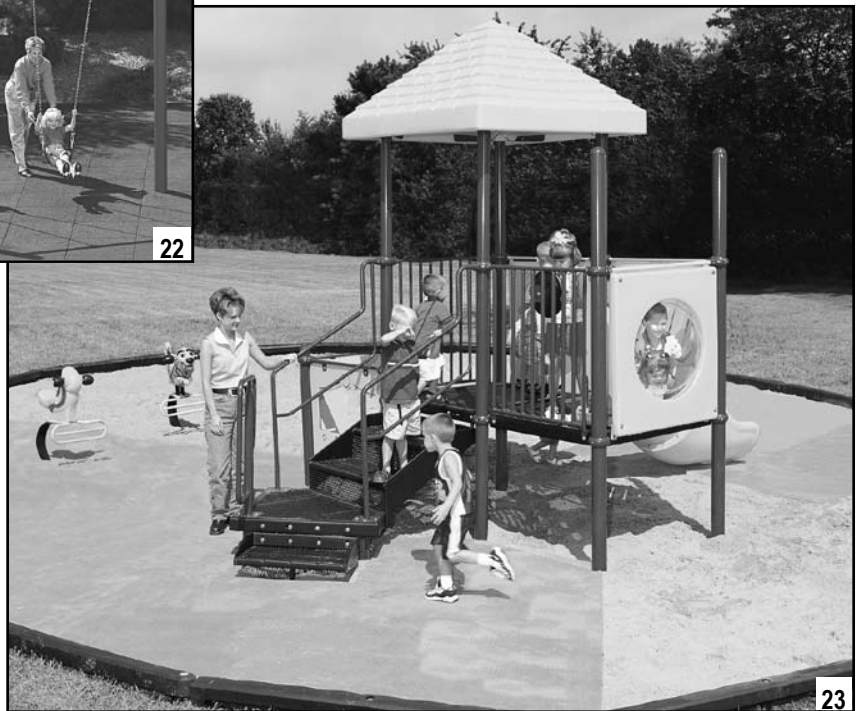
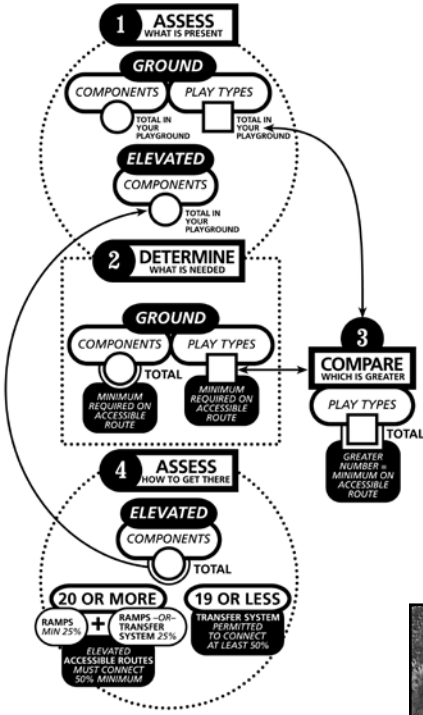

The above step-by-step guide is intended to assist when applying the play area guidelines. A detailed description is provided on page 17.

A “ground-level play component” is a play component that is approached and exited at the ground level.



HOW MANY PLAY COMPONENTS MUST BE ON AN ACCESSIBLE ROUTE?

Ground Level Requirements Based on Elevated Play Components

The number and variety of ground-level play components required to be on an accessible route is also determined by the number of elevated components provided in the play area.

The intent of this requirement is to provide a variety of experiences for individuals who choose to remain with their mobility aids, or choose not to transfer to elevated play components.

| Number of elevated play components provided | Minimum number of ground-level play components required to be on accessible route | Minimum number of different types of ground-level play components required to be on accessible route |
|---|---|--|
| 1 | Not applicable | Not applicable |
| 2 to 4 | 1 | 1 |
| 5 to 7 | 2 | 2 |
| 8 to 10 | 3 | 3 |
| 11 to 13 | 4 | 3 |
| 14 to 16 | 5 | 3 |
| 17 to 19 | 6 | 3 |
| 20 to 22 | 7 | 4 |
| 23 to 25 | 8 | 4 |
| More than 25 | 8 plus 1 for each additional 3 over 25, or fraction thereof | 5 |

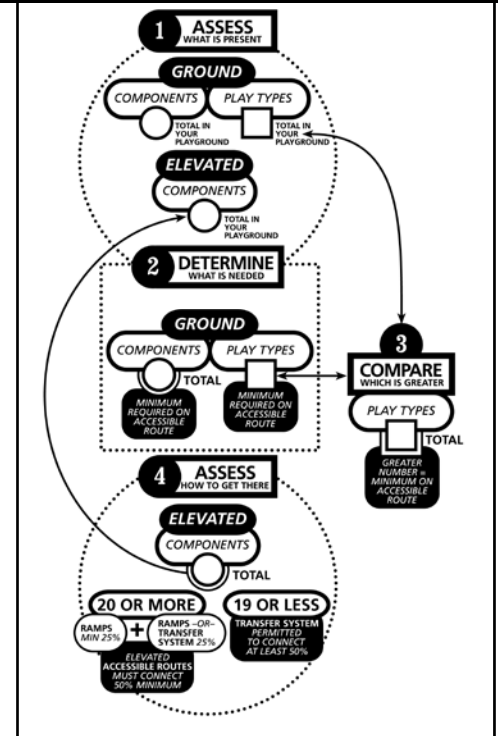

If ramps provide access to at least 50 percent of the elevated play components - which must include at least three different play types - then additional ground-level components are not required.

In the play area shown on page 14, the composite structure has four elevated play components (bubble panel, slide, steering wheel, and tic-tac-toe panel). According to the table, a minimum of one ground level play component must be provided, and a minimum of one different type. The spring rider or swing can be used to meet the “one of each type” requirement and can also be used to meet the minimum number determined by Table 240.2.1.2.

Elevated Play Components

At least 50 percent of the elevated play components must be on an accessible route.



Play areas with 20 or more elevated components must use ramps to connect a minimum of 25 percent of those components. A transfer system or ramps may connect the other elevated play components required on an accessible route.

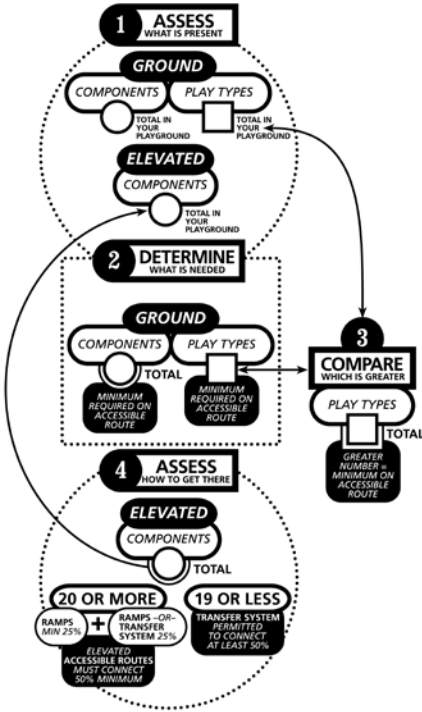

The above step-by-step guide is intended to assist when applying the play area guidelines. A detailed description is provided on page 17.

An “elevated play component” is a play component reached from above or below grade, and is part of a composite play structure.



Play areas with less than 20 elevated play components may use a transfer system instead of ramps to connect at least 50 percent of the elevated components.



Step-by-Step Guide

The following step-by-step guide has been provided to assist in evaluating a play area for meeting the minimum requirements of these guidelines. The guide has been arranged in four steps and provides spaces to fill in numeric values of play components for evaluating a specific play area design.

The step-by-step guide is used throughout the remainder of this guide as a key, shown in the upper corner of each new section where it applies.

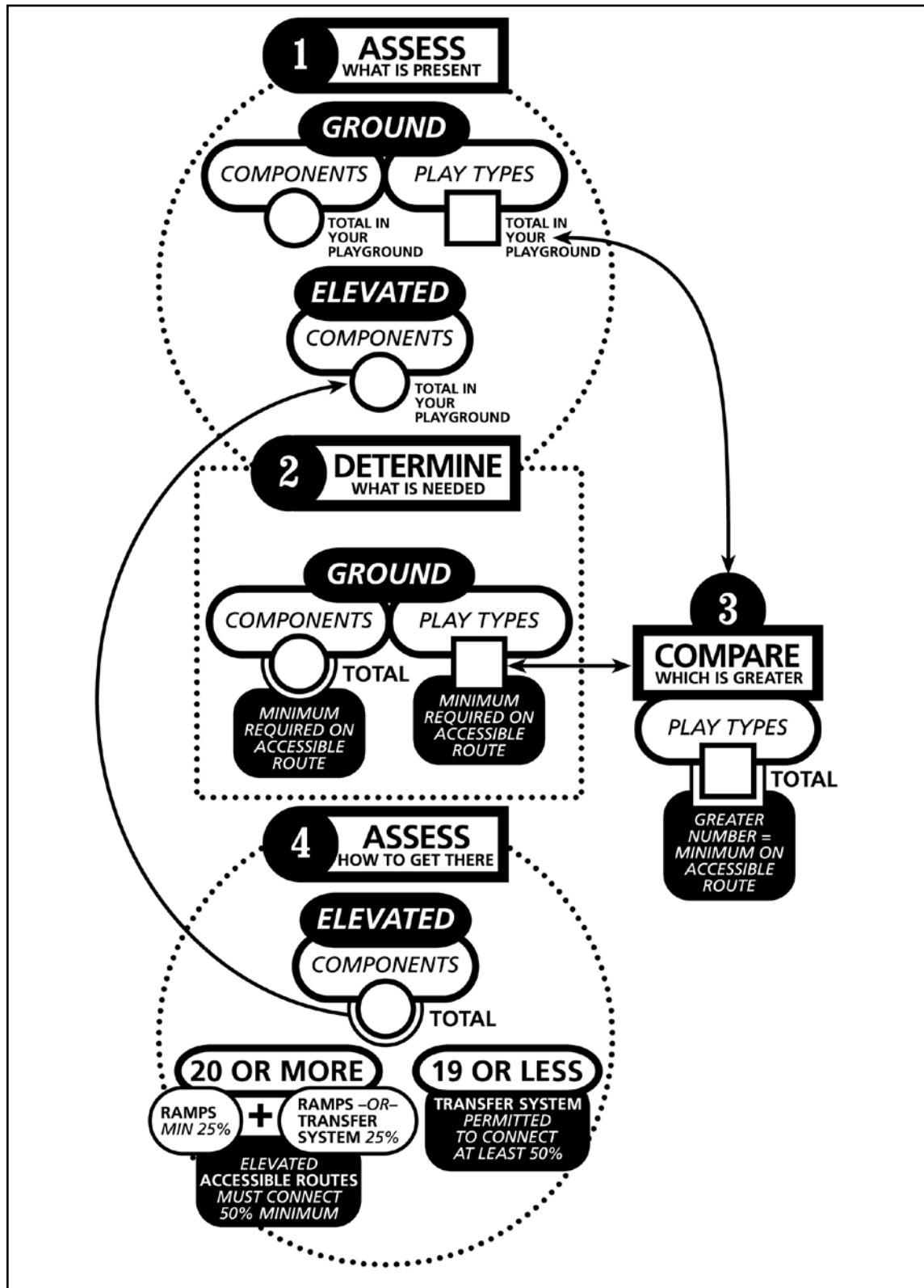

PLAY AREA EVALUATION EXAMPLE

The example below illustrates a proposed design for a new play area. Each section illustrated in the flow chart provides guidelines for the following design tasks:

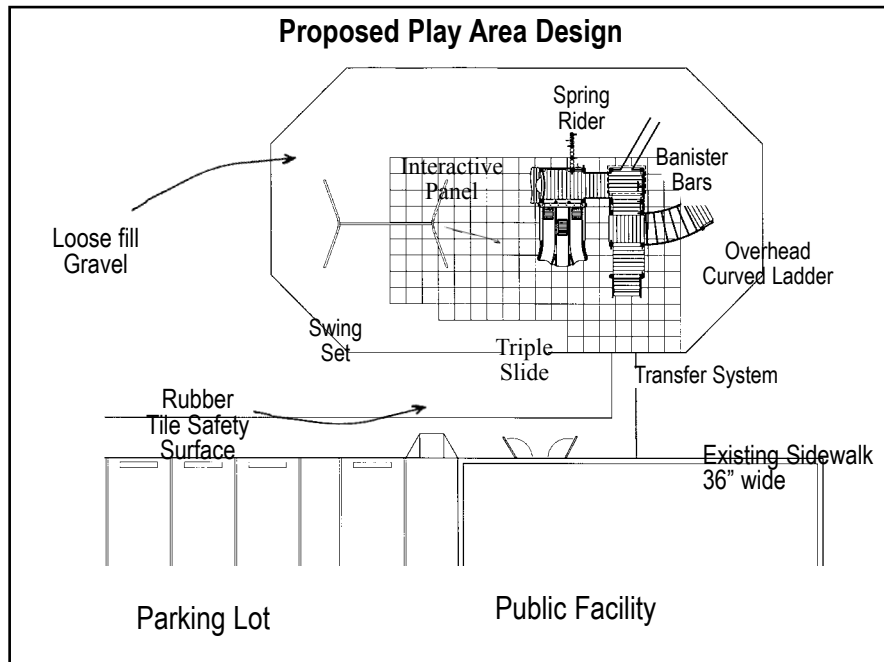

- Determining the number of play components
- Assessing the variety of play types
- Determining how many play components must be on an accessible route
- Determining when ramps are required and when transfer systems are permitted

Refer to this example while reviewing the concepts explained in this guide, to review how accessibility guidelines are applied to play area designs.

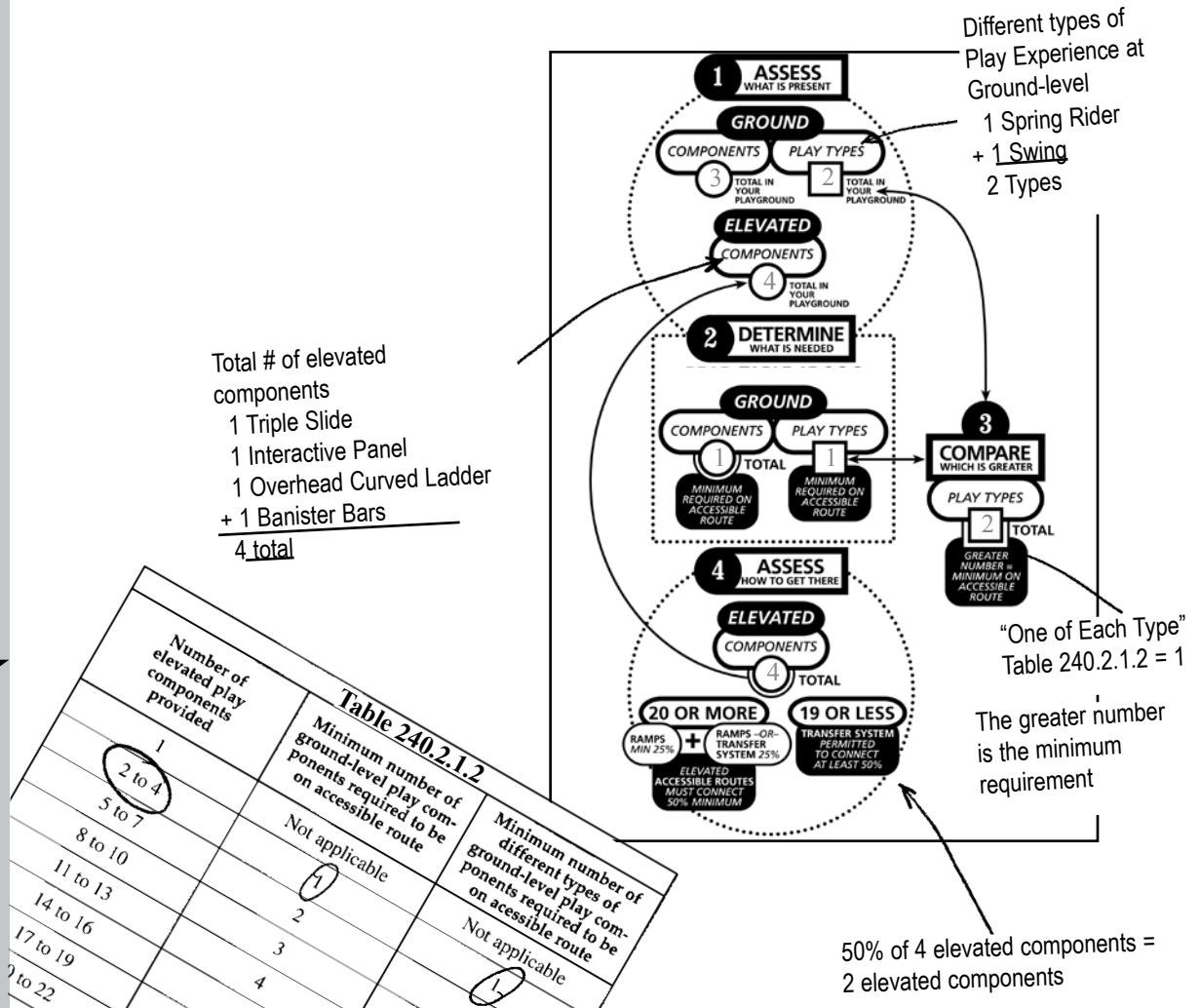

Table 240.2.1.2

| Number of elevated play components provided | Minimum number of ground-level play components required to be on accessible route | Minimum number of different types of ground-level play components required to be on accessible route |
|---|---|--|
| 1 | 2 to 4 | 1 |
| 2 to 4 | 5 to 7 | 2 |
| 5 to 7 | 8 to 10 | 3 |
| 8 to 10 | 11 to 13 | 4 |
| 11 to 13 | 14 to 16 | Not applicable |
| 14 to 16 | 17 to 19 | Not applicable |
| 17 to 19 | 20 to 22 | Not applicable |

WHAT ARE THE REQUIREMENTS FOR ACCESSIBLE ROUTES?

ADAAG chapter 4 addresses accessible routes that connect the play area to the school, parking lot, or facility that it serves. Operators or owners of play areas are subject to all the other requirements of the ADA, including the obligation to provide individuals with disabilities an equal opportunity to enjoy the play area provided by that facility.

This section describes the various features of accessible routes within a play area, including location, clear width, slope, and accessible surfaces.

Accessible Routes

An accessible route is a pathway specifically designed to provide access for individuals with disabilities, including those using wheelchairs or mobility devices.



Accessible routes inside the boundaries of play areas are addressed in the play area guidelines. Technical provisions address the width, slope, and surface of both ground-level and elevated accessible routes.

There are two types of accessible routes:

- Ground-level
- Elevated



This ground-level route connects ground components and the transfer system which connects elevated components.

This elevated route connects elevated play components on a composite structure.



The accessible route must connect all entry and exit points of accessible play components.

Clear floor space required at play components and maneuvering space can overlap the accessible route.

Incorporating additional circulation space around high-use play components creates extra room for movement and accessibility for everyone using the play area.



U.S. Access Board
A Summary of Accessibility
Guidelines for Play Areas

Ground-Level Accessible Routes

The 80-inch vertical clearance applies to ground-level routes only, and not elevated routes. This allows features like protective roofs and sun shelters to be present.

A ground-level accessible route connects play components at ground level.

- 60 inches (1525 mm) minimum clear width
- 1:16 maximum slope

The route may narrow down to 36 inches (915 mm) for a distance of 60 inches (1525 mm). This permits flexibility to work around site design features like existing equipment or trees.

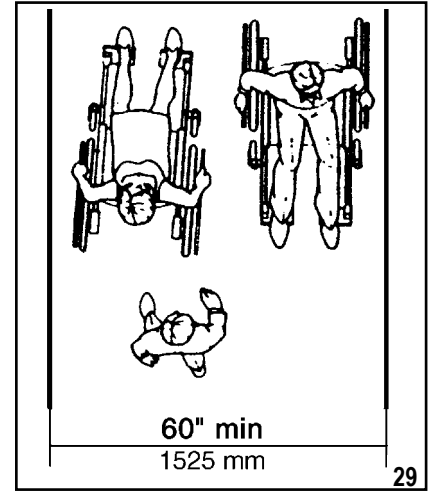
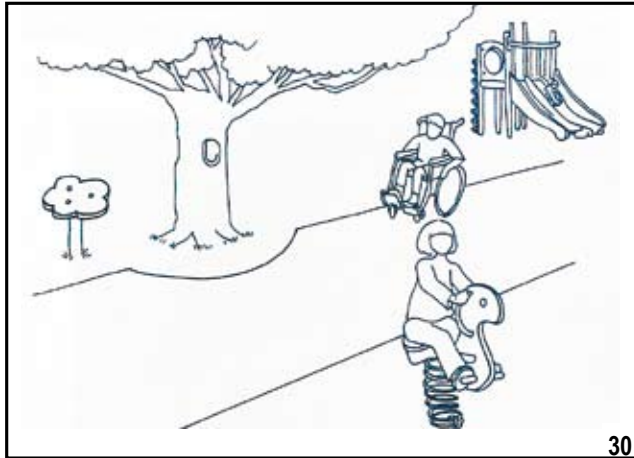

The required 60-inch width enables two wheelchairs to pass each other or to change direction.

Smaller play areas - those that are less than 1,000 square feet (93 square meters) - may have ground-level accessible routes that are 44 inches (1120 mm) clear width. A wheelchair turning space must be provided where the route exceeds 30 feet (9.14 mm) in length.

At ground level, objects may not protrude into the 60-inch wide space of an accessible route up to or below the height of 80 inches (2030 mm), measured above the accessible route surface. The 80-inch clearance applies only to the 60-inch accessible route, and is not required for the entire play area.

The play area provides a fun accessible roadway theme. The protective shelters for the benches have been set outside the boundary of the route providing the 80 inches of clearance required on the route.



WHAT ARE THE REQUIREMENTS FOR ACCESSIBLE ROUTES?

Ground-Level Accessible Routes

Maximum Slope at Ground Level

The maximum allowable slope for a ground-level accessible route is 1:16.

Berms are sometimes used to provide access to elevated play areas. A berm may be a natural sloped surface that is present in a hilly play area site, or a ground-level route built with slopes.

Designers are encouraged to consider edge protection and handrails on berms where there may be a drop-off. Remember the maximum slope of this “ground-level accessible route” is 1:16.

However, handrails are not required on ground-level accessible routes. This is permitted since the handrails may become a safety hazard in the “use zone.”



This play area provides a bermed accessible route.



To accommodate a height change along the perimeter of a play area - like these rubber safety tiles placed on an asphalt surface - an allowable 1:12 slope is utilized for the transition at the boundary of the play area.



U.S. Access Board
A Summary of Accessibility
Guidelines for Play Areas

Accessible Ground Surfaces

The “use zone” is a ground level area beneath and immediately adjacent to a play structure or piece of equipment that is designated for unrestricted circulation around the equipment. It is predicted that a user would fall and land or exit the equipment on the surface of the use zone.

The American Society for Testing and Materials (ASTM) has established safety standards for play areas, including resilient surfaces. For further information or to purchase these standards, contact ASTM, 100 Barr Harbor Drive, West Conshohocken, PA 19428-2959, www.astm.org.

Ground surfaces along accessible routes, clear floor or ground spaces, and maneuvering spaces, must comply with the American Society for Testing and Materials (ASTM) F 1951-99 *Standard Specification for Determination of Accessibility to Surface Systems Under and Around Playground Equipment*.

This standard assesses the accessibility of a surface by measuring the work an individual must exert to propel a wheelchair across the surface. The standard includes tests of effort for both straight-ahead and turning movements, using a force wheel on a rehabilitation wheelchair as the measuring device. To meet the standard, the force required must be less than that which is required to propel the wheelchair up a ramp with a slope of 1:14.

When selecting ground surfaces, operators should request information about compliance with the ASTM F 1292-04 standard.



Accessible surfaces can include impact-attenuating tiles made of recycled rubber and engineered wood fiber that meet the ASTM requirements for accessibility and safety. The design can be created so safety is not compromised for individuals using the play area where both standards are applied.

Accessible Surfaces Located In The Use Zone

If located within the use zone, accessible ground surfaces must also be impact attenuating and meet ASTM F 1292-04 *Standard Specification for Impact Attenuation of Surface Systems Under and Around Playground Equipment*.



U.S. Access Board
A Summary of Accessibility
Guidelines for Play Areas

WHAT ARE THE REQUIREMENTS FOR ACCESSIBLE ROUTES?



Accessible and non-accessible surfaces can be combined to provide variety and excitement in the play area.



Rubber surfacing tiles facilitate access in this play area.

Ground surfaces must be inspected and maintained regularly and frequently to ensure continued compliance with the ASTM F 1292-04 standard. The frequency of maintenance and inspection of resilient surfacing depends on the amount of use and the type of surfacing installed.



Accessible surfacing can be designed to complement the theme of the play area, while providing full access and visually integrating the surface into the overall design. Individuals of all abilities will enjoy the added benefits of an imaginative design.

Engineered wood fiber surfaces will require frequent maintenance to comply with the ASTM F 1292-04 standard because of surface displacement due to user activity or other factors.

Designers and operators are likely to choose materials that best serve the needs of each play area. The type of material selected will affect the frequency and cost of maintenance.



At the time of this publication, rubber surfacing and some engineered wood fiber products meet the ASTM F 1951-99 standard. The fact that a specific product meets the ASTM 1951-99 standard does not necessarily mean that all other similar products will meet the standard.

Operators interested in selecting surfaces to comply with the play area guidelines, should consult individual product manufacturers to determine compliance with ASTM F 1951-99.



**U.S. Access Board
A Summary of Accessibility
Guidelines for Play Areas**

Elevated Accessible Routes

“Ramps” serve as a continuation of the accessible route from the ground allowing individuals who use mobility devices to access elevated components. The guidelines require that play areas containing 20 or more elevated play components provide ramp access to at least 25 percent of those elevated components.

An elevated accessible route is the path used for connecting elevated play components.

Elevated accessible routes must connect the entry and exit points of at least 50 percent of the elevated play components provided in the play area.

Two common methods for providing access to elevated play components are ramps and transfer systems. Ramps are the preferred method since not all children who use wheelchairs or other mobility devices may be able to use - or may choose not to use - transfer systems.



This photo illustrates an elevated accessible route:

- 36-inch (915 mm) clear width
- 32-inch (815 mm) narrowed width permitted for 24-inch (610 mm) length to accommodate features in the composite structure
- 12-inch (305 mm) rise maximum per ramp run
- Top of handrail gripping surfaces shall be 20 inches (510 mm) minimum to 28 inches (710 mm) maximum above the ramp surface



The 80-inch vertical clearance height does not apply to elevated accessible routes. This allows for the use of features such as roofs and sun shelters.



WHAT ARE THE REQUIREMENTS FOR ACCESSIBLE ROUTES?

When Ramps Are Required

Ramps are required on composite structures with 20 or more elevated play components and must connect to at least 25% of the elevated play components.

Ramps allow individuals who use wheelchairs and mobility devices to access elevated play components in composite play structures without transferring.



This play area has more than 20 play components and provides ramp access to elevated play components. The ramp system, consisting of ramp runs and landings, must connect at least 25 percent of the elevated play components. The balance of the elevated play components required to be on an accessible route may be connected by the ramp system, or by a transfer system.

Rise of a ramp is the amount of vertical distance the inclined or slanted surface ascends or descends. A ramp **run** is a length of a continuous sloped surface that is ascending or descending. For example, to reach a 12-inch high deck or platform, a designer could use a 12-foot ramp with the maximum 1:12 slope, or a 14-foot ramp with a less steeper 1:14 slope.

Platform lifts, also known as “wheelchair lifts,” may be considered for providing access to elevated play components when appropriate.

Where applicable, platform lifts complying with ADA/ABA Accessibility Guidelines chapter 4 and applicable state and local codes are permitted as a part of an accessible route. Because lifts must be independently operable, owners and operators should carefully consider the appropriateness of their use in unsupervised settings.



U.S. Access Board
A Summary of Accessibility
Guidelines for Play Areas

“Ramps” are sloped surfaces that provide individuals who use mobility devices with access to elevated components.

Ramps

For each elevated ramp run:

- 12-inch (305 mm) maximum rise
- 1:12 maximum slope
- 36-inch (915 mm) minimum clear width



Landings

Landings are the level surfaces at the top and bottom of each ramp run.

- Must be as wide as the ramp they connect to
- A minimum length of 60-inches (1525 mm)
- If ramps change direction, the minimum landing size must be 60 inches (1525 mm) wide to accommodate a turn

Maneuvering Space Where Ramps are Provided

At least one maneuvering space must be provided on the same level as the play component. The space must have a slope no steeper than 1:48 in all directions (see page 34 for further details).

ADA/ABA Accessibility Guidelines addresses additional requirements for ramps and landings including edge protection, cross slope, surfaces, and outdoor conditions.



WHAT ARE THE REQUIREMENTS FOR ACCESSIBLE ROUTES?

Handrails

Handrails are required on both sides of ramps connecting elevated play components. Handrails must comply with the following:

- Clearance between handrail gripping surfaces and adjacent surfaces and shall not be 1 1/2 inches (38mm) minimum.
- Handrail gripping surfaces shall be continuous along their length and shall not be obstructed along their tops or sides. The bottoms of handrail gripping surfaces shall not be obstructed for more than 20 percent of their length. Where provided, horizontal projections shall occur 1 1/2 inches (38mm) minimum below the bottom of the handrail gripping surface.



In this case, additional handrails have been provided.

Handrails are required to comply with ADA/ABA 505. However, extensions on handrails in the play area are not required. This is to prevent children running into protruding rails in the play area.



**U.S. Access Board
A Summary of Accessibility
Guidelines for Play Areas**

When Transfer Systems Are Used

A “transfer system” is an alternative to a ramp system in play areas where there are less than 20 total elevated play components.

The transfer system must connect to the ground-level accessible route and provide access to at least 50 percent of the elevated play components.

A transfer system provides access to elevated play components within a composite system by connecting different levels with transfer platforms and steps.

A transfer system provides access to elevated play components without the use of a wheelchair or mobility device. At least 50% of the elevated play components can be connected by a transfer system in play areas with less than 20 elevated components. In play areas with 20 or more elevated play components, transfer systems may be used to connect up to 25% of the elevated play components and the rest of the elevated play components required to be on an accessible route must be connected by a ramp.



A transfer system typically consists of a transfer platform, transfer steps, and transfer supports.

Where a transfer system is provided, a combination of transfer platforms and transfer steps provide a continuous accessible route to elevated play components. A transfer system provides individuals the space necessary to physically transfer up or down in a composite play structure. Where provided, a 24-inch (610 mm) minimum width is necessary for individuals moving around a structure.



Playful features can be part of the transfer system, providing interactive experiences from both an elevated or ground level approach.

Consider the distance someone must travel to reach play components accessed by transfer systems. On page 31, the illustration shows a transfer system placed directly next to the slide. Access to this type of elevated play component has been carefully designed to minimize the distance someone must transfer to reach it.

WHAT ARE THE REQUIREMENTS FOR ACCESSIBLE ROUTES?

Transfer Platforms

A transfer platform is a platform or landing that an individual who uses a wheelchair or mobility device can use to lift or *transfer* onto the play structure and leave the wheelchair or mobility device behind at ground-level.



- 11 inches (280 mm) to 18 inches (455 mm) height of top surface
- Minimum 24 inches (610 mm) wide
- Minimum 14 inches (355 mm) deep
- Unobstructed side

Adding a transfer step that leads to the ground's surface increases access for children exiting components at the ground level.

Transfer steps in a play area are not required to satisfy the general ADAAG stair requirements.

Maneuvering space and clear space is not required on elevated structures or at elevated play components reached by a transfer system.

Clear floor or ground space - used for parking wheelchair or mobility devices (commonly called “wheelchair parking”) - is required at the transfer platform.

The 48-inch long side (1200 mm) of the “wheelchair parking” space must be parallel to the 24-inch (610 mm) side of the transfer platform.

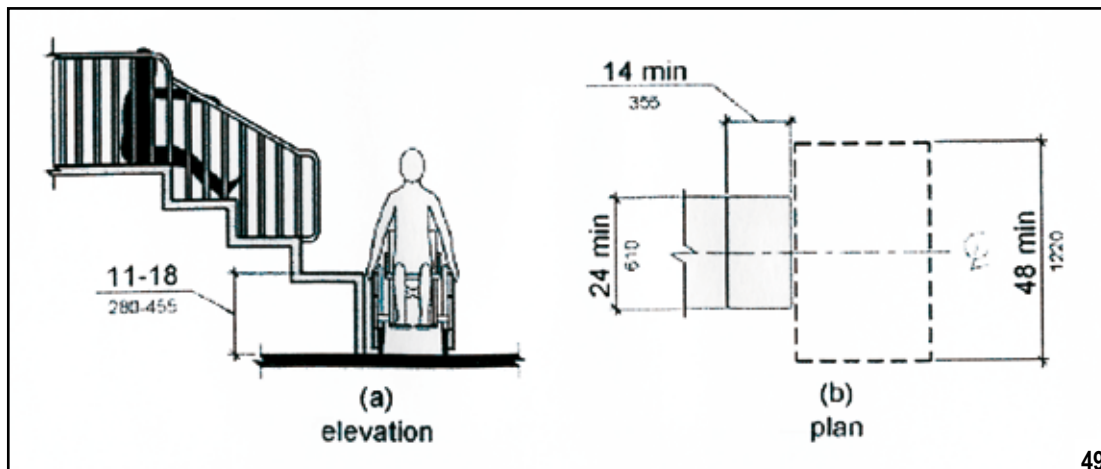

U.S. Access Board
A Summary of Accessibility
Guidelines for Play Areas

Transfer steps are level surfaces in a composite structure that can be used for transferring from different levels to access play components.

Transfer Steps

- Minimum 24 inches (610 mm) wide
- Minimum 14 inches (355 mm) deep
- 8 inches (205 mm) maximum height

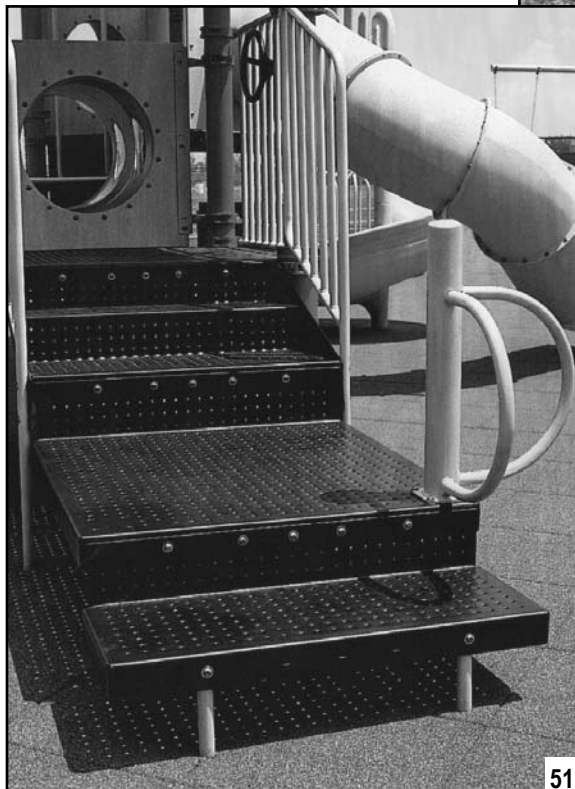

Play areas intended for smaller children should provide steps at smaller height increments. This will accommodate smaller sized children who must lift or “bump” up each step.



WHAT ARE THE REQUIREMENTS FOR ACCESSIBLE ROUTES?

Transfer Supports

Transfer supports must be provided on transfer platforms and transfer steps at each level where transferring is the intended method of access.

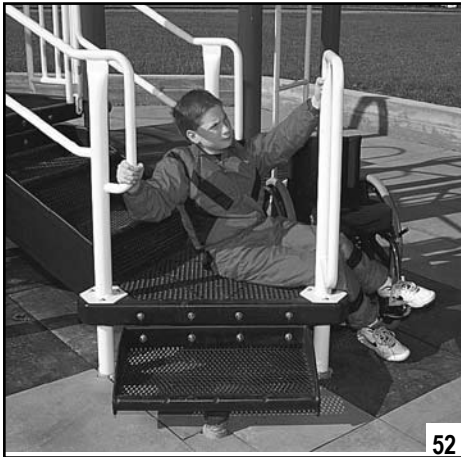

Materials in a variety of different shapes and sizes are used to manufacture transfer supports including metal, plastic, and rope.

A means of support is required when transferring into the entry or seat of a play component.

Transfer supports assist individuals with transferring and general mobility. They include handrails, handgrips, or custom designed handholds.

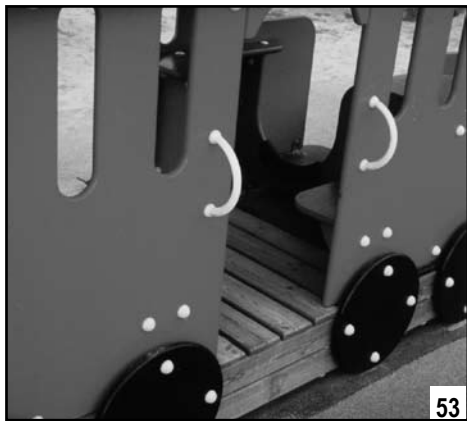

Aesthetically pleasing cut-out shapes and other design enhancements can provide hand supports for transferring.

Consideration must be given to the distance between the transfer system and the elevated play components it is intended to facilitate. Designers should minimize the distance between the point where a child transfers from a wheelchair or mobility device and the elevated play destination.

This transfer system provides access to exciting elevated play experiences like sliding while minimizing the distance individuals must traverse.

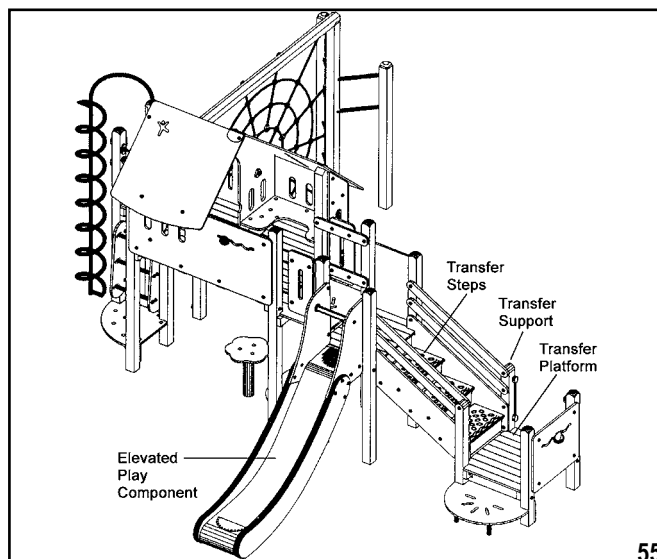

U.S. Access Board
A Summary of Accessibility
Guidelines for Play Areas

Connected Elevated Components

Elevated play components that are connected to other play components count toward fulfilling the requirement for the number of elevated components on an accessible route where transfer systems are used.

When transfer systems are used, an elevated play component may connect to other elevated play components, providing an innovative, accessible route.

A crawl tube is an elevated play component in this composite structure. Going through the tunnel provides access to additional activities on the other side.



56

Consideration should be given to how a play component is utilized when it is selected to connect to other elevated play events. When a transfer system is provided, children move through a play component like this crawling tube, using their own strength without a mobility device.



Providing variety and excitement through elevated play spaces benefits all children. Tunnels and tubes make “getting there” an activity in itself.

57



WHAT OTHER ACCESSIBILITY REQUIREMENTS APPLY TO PLAY COMPONENTS?

The play area guidelines address accessible routes connecting play components along with certain spaces that are crucial to making a play area usable for children with disabilities. The other requirements for play components are provided to promote general usability, with application to a variety of play components. Additional features will assist in making play components more accessible to more children. Designers are encouraged to consider components with back support, increased space for maneuvering adjacent to the play component, and other features that promote independent use.

Clear Floor or Ground Space

Clear floor space - also known as ground space - provides unobstructed room to accommodate a single stationary wheelchair and its occupant at a play component on an accessible route.

- 30-inch (760 mm) by 48-inch (1220 mm) minimum area
- May overlap accessible routes and maneuvering spaces
- Slope not steeper than 1:48 in all directions



The clear floor space is permitted to overlap onto the landing area to provide access to this elevated window activity.

Play components come in a variety of shapes and sizes facilitating a broad range of experiences. A specific location for clear floor or ground space has not been designated. Each play component is unique and the spaces must be placed in the best location for the situation.

This interactive play component has a clear ground space that allows front or side reach interaction.



Elevated play components accessed by transfer systems do not require maneuvering or clear floor spaces, since mobility devices are left at ground level.

Clear floor or ground space is also sometimes called "wheelchair parking space."

The minimum clear floor or ground space on a composite structure may be positioned for a forward or parallel approach. It may overlap accessible routes and maneuvering spaces.



U.S. Access Board
A Summary of Accessibility
Guidelines for Play Areas

Maneuvering Space

Maneuvering space is defined as the space required for a wheelchair to make a 180-degree turn. At least one maneuvering space must be provided on the same level as elevated play components.

When providing access to ground level and elevated play components by ramps, space allowances to accommodate wheelchairs and mobility devices are required.

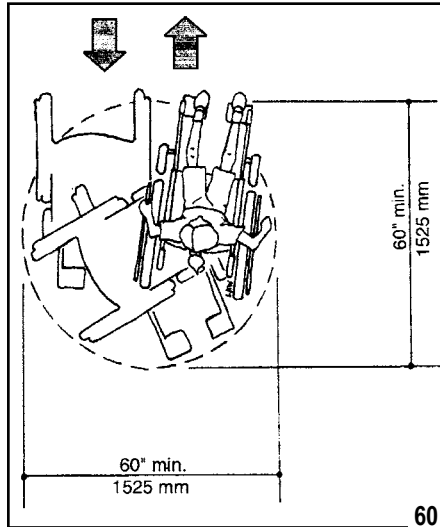

- A 60-inch (1525 mm) turning circle permits individuals with mobility devices to turn around
- A 60-inch (1525 mm) T-Shaped turn allows an individual to change directions by making a series of multi-point turns
- Slope not steeper than 1:48 in all directions

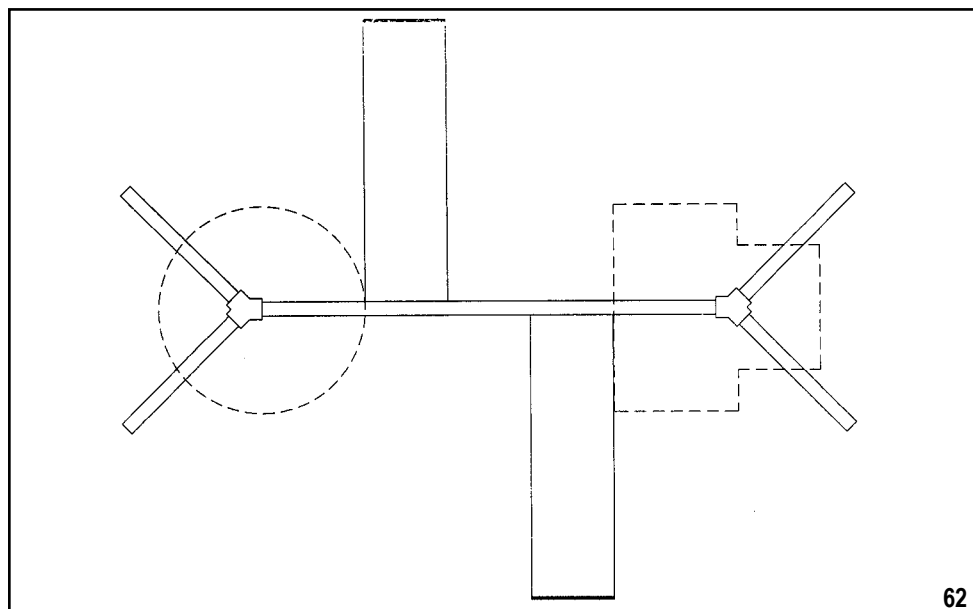
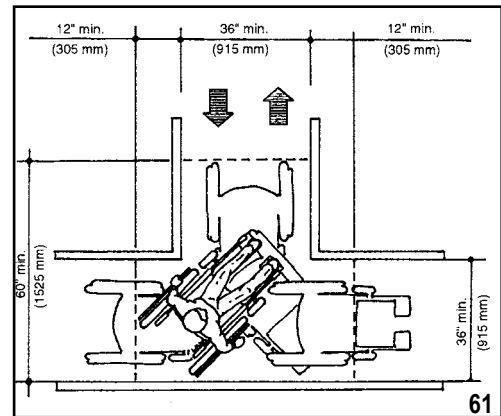

Maneuvering space is required for swings and must be located adjacent to the swing. This illustration shows options for either a 60-inch turning circle or a T-shaped turn. While this illustration shows the maneuvering space to the side of the swing, the space may be located behind or in front of the swing as long as it is immediately adjacent to the swing.

Objects are not permitted to protrude into ground level maneuvering spaces at or below 80 inches (2030 mm) above the ground or floor surface.



Entry Points and Seats

Entry points and seats are features of play components where individuals would transfer, sit, or gain access. When play components are located on an accessible route, the height required to transfer directly to the entry point or seat of a play component has a minimum of 11 inches (280 mm) and a maximum of 24 inches (610 mm). A mid-level height of 18 inches (455 mm) is recommended.



Examples of entry points and seats include swing seats, spring rocker seats, and crawl-tube openings.



Consider design features like open sides, back supports, and hand supports to help facilitate easy transfer and access.

The height of the entry point of a slide is not specified.



**U.S. Access Board
A Summary of Accessibility
Guidelines for Play Areas**

Play Tables

Play tables may be located at a ground or elevated level in a composite play structure. Consider the route, clear floor space and maneuvering spaces for tables intended to be accessible to individuals who use wheelchairs.

Play tables are surfaces, boards, slabs, or counters that are created for play. This includes tables designed for sand and water play, gathering areas, and other activities. Where play tables are located on an accessible route, the wheelchair knee clearance minimums are:

- 24 inches (610 mm) high minimum
- 30 inches (760 mm) wide minimum
- 17 inches (430 mm) deep minimum



Play tables designed primarily for children under 5-years-old, may provide a parallel approach instead of knee clearance if the rim is a maximum of 31 inches (785 mm) high.

The edge of this elevated sand table has been designed to provide access by providing a generous opening. The tops of rims, curbs, or other obstructions that would prevent access to a table surface should be 31 inches (785 mm) maximum in height.



Reach Ranges (Advisory)

The play area guidelines include advisory information on recommended reach ranges.

Reach ranges are the recommended designated regions of space that a person seated in a wheelchair can reasonably extend their arm or hand to touch, manipulate, move, or interact with an object or play component.

Reach ranges should be considered when providing play components with manipulative or interactive features for children who use wheelchairs. Recommended forward or side reach ranges are:

- 20 to 36 inches for 3 to 4 year-olds
- 18 to 40 inches for 5 to 8 year-olds
- 16 to 44 inches for 9 to 12 year-olds

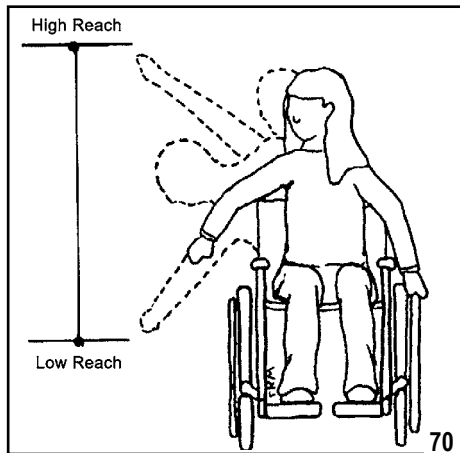

Side Reach

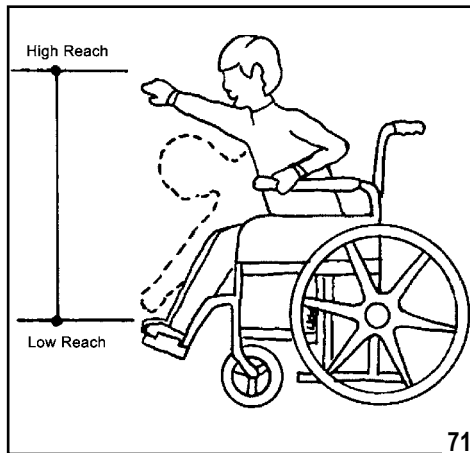

Forward Reach

The reach ranges appropriate for use by children who use wheelchairs to access play components are intended for ground-level components, and elevated components accessed by ramps. Reach ranges are not appropriate for play components reached by transfer systems.



Appropriate reach range heights will vary depending on how the play component is accessed. This interactive panel is mounted at a height appropriate for a child who uses a wheelchair.

The reach ranges in this guide are recommendations that should be considered when designing play components with manipulative features intended for use by individuals who use wheelchairs.



SOFT CONTAINED PLAY STRUCTURES

“Soft contained play equipment” is a play structure made of one or more components, on which an individual enters a fully enclosed play environment that uses pliable materials such as plastic, soft padding, and fabric.

Soft contained play structures must provide at least one entry point on an accessible route when three or fewer entry points are provided.

If four or more entry points are provided, at least two entry points must be located on an accessible route.

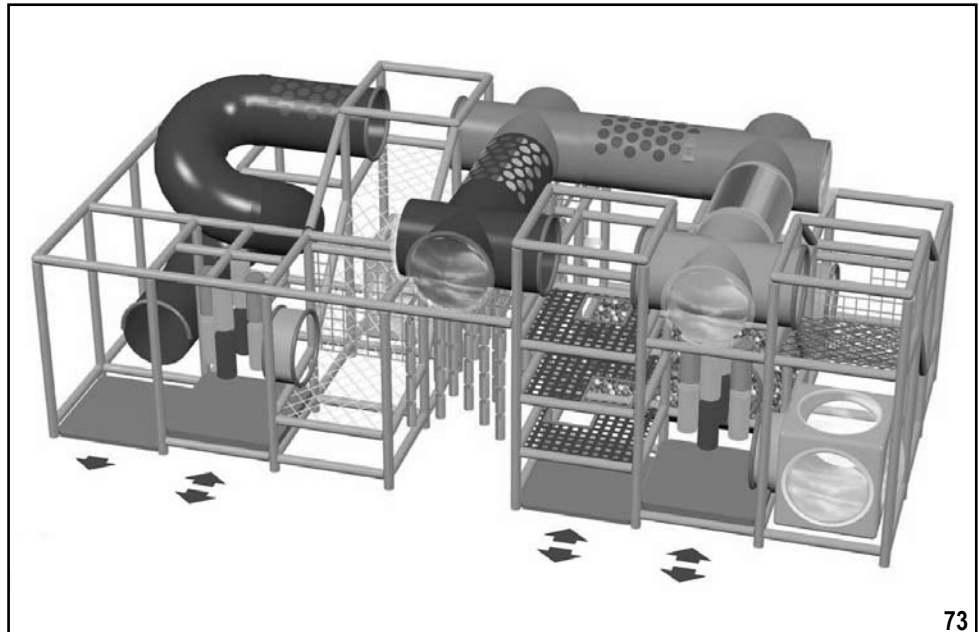

Soft contained play environments typically have limited entrance and exit locations, with play components integrated into the system design.



Transfer systems or platform lifts can serve as a part of an accessible route connecting entry points on soft-contained play structures.



U.S. Access Board
A Summary of Accessibility
Guidelines for Play Areas

The play area guidelines apply to alterations made to existing play areas that affect, or could affect, the usability of the play area. Examples include removing a climbing play component and replacing it with a spring rocker, or changing the ground surfacing.

Alterations provide an opportunity to improve access to existing play areas. Where play components are altered and the ground surface is not, the ground surface does not have to comply with the ASTM F 1951-99 standard for accessible surfaces unless the cost of providing an accessible surface is less than 20 percent of the cost of the alterations to the play components.

If the entire ground surface of an existing play area is replaced, the new ground surface must provide an accessible route to connect the required number and types of play components. The requirements for accessible routes are explained on page 19.



This play area was altered by adding two spring rockers. The seat of at least one spring rocker is between 11 inches (280mm) and 24 inches (610mm) maximum, and clear floor or ground space and maneuvering space is provided. If the ground surface is replaced in the future, an accessible route would have to be provided to the spring rocker.

Normal maintenance activities such as replacing worn ropes or topping off ground surfaces are not considered alterations.

If play components are relocated in an existing play area to create safe use zones, the guidelines do not apply, provided that the ground surface is not changed or extended for more than one use zone.

Replacing the entire ground surface does not require the addition of more play components.



U.S. Access Board
A Summary of Accessibility
Guidelines for Play Areas

ACKNOWLEDGEMENTS

The Access Board would like to thank the following manufacturers for their generous assistance and for supplying appropriate photographs or illustrations: Bob Leathers, Columbia Cascade, GameTime, KOMPAN, Landscape Structures, Little Tikes, Miracle, Olympic Recreation, Playworld Systems, and Recreation Creations.

The numerical listing below shows the source of each photo or illustration.

| | |
|------------------------------|--------------------------|
| Top Cover Photo - KOMPAN | 38. KOMPAN |
| Bottom Cover Photo - Miracle | 39. KOMPAN |
| 1. KOMPAN | 40. GameTime |
| 2. Little Tikes | 41. GameTime |
| 3. KOMPAN | 42. GameTime |
| 4. KOMPAN | 43. Playworld Systems |
| 5. KOMPAN | 44. Landscape Structures |
| 6. Little Tikes | 45. Miracle |
| 7. KOMPAN | 46. Landscape Structures |
| 8. Little Tikes | 47. Little Tikes |
| 9. KOMPAN | 48. Landscape Structures |
| 10. KOMPAN | 49. KOMPAN |
| 11. Landscape Structures | 50. Game Time |
| 12. Miracle | 51. Recreation Creations |
| 13. KOMPAN | 52. Miracle |
| 14. Little Tikes | 53. KOMPAN |
| 15. GameTime | 54. Playworld Systems |
| 16. Playworld Systems | 55. KOMPAN |
| 17. GameTime | 56. KOMPAN |
| 18. Little Tikes | 57. KOMPAN |
| 19. Landscape Structures | 58. Olympic Recreation |
| 20. Miracle | 59. Playworld Systems |
| 21. Recreation Creations | 60. KOMPAN |
| 22. Miracle | 61. KOMPAN |
| 23. Miracle | 62. Access Board |
| 24. Landscape Structures | 63. Playworld Systems |
| 25. Miracle | 64. Little Tikes |
| 26. Columbia Cascade | 65. Landscape Structures |
| 27. Playworld Systems | 66. GameTime |
| 28. GameTime | 67. Playworld Systems |
| 29. KOMPAN | 68. Landscape Structures |
| 30. Elizabeth Garufi | 69. Bob Leathers |
| 31. Little Tikes | 70. KOMPAN |
| 32. Playworld Systems | 71. KOMPAN |
| 33. KOMPAN | 72. Miracle |
| 34. Columbia Cascade | 73. GameTime |
| 35. KOMPAN | 74. Access Board |
| 36. KOMPAN | 75. Miracle |
| 37. Little Tikes | |

