

## ORDER FOR CONDUIT LOCATION

By the City Council  
of the City of Salem, Massachusetts.

### ORDERED:

That permission be and hereby is granted the **VERIZON NEW ENGLAND INC.** to lay and maintain underground conduits and manholes, with the wires and cables to be placed therein, under the surface of the following public way or ways as requested in petition of said Company dated the 17th day of February, 2017.

**DERBY STREET:** Place approximately 10 feet of underground conduit from existing Verizon Manhole No. 32 in a Southerly direction to private property at 24 Fort Avenue.

Substantially as shown on plan marked – **Verizon N.E., Inc.** No. P2017-4AFR8C, Dated February 17, 2017- filed with said petition.

Also that permission be and hereby is granted said **VERIZON NEW ENGLAND INC.** to lay and maintain underground conduits, manholes, cables and wires in the above or intersecting public ways for the purpose of making connections with such poles and buildings as it may desire for distributing purposes.

The foregoing permission is subject to the following conditions:--

The conduits and manholes shall be of such material and construction and all work done in such manner as to be satisfactory to such municipal officers as may be appointed to the supervision of the work, and a plan showing the location of conduit constructed shall be filed with the City when the work is completed.

Said Company shall indemnify and save the City harmless against all damages, costs and expense whatsoever to which the City may be subjected in consequence of the acts or neglect of said Company, its agents or servants, or in any manner arising from the rights and privileges granted it by the City.

In addition said Company shall, before a public way is disturbed for the laying of its wires or conduits, execute its bond in a penal sum of 20 Thousand Dollars (\$20,000.00) (reference being had to the bond already on file with said City) conditioned for the faithful performance of its duties under this permit.

Said Company shall comply with the requirements of existing ordinances and such as may hereafter be adopted governing the construction and maintenance of conduits and wires, so far as the same are not inconsistent with the laws of the Commonwealth.

I hereby certify that the foregoing order was adopted at a meeting of the City Council of the City of Salem, Massachusetts held on the \_\_\_ day of \_\_\_\_\_, 2017 .

---

City Clerk

**PETITION PLAN  
VERIZON NEW ENGLAND INC**

Municipality: Salem, Massachusetts

No. P2017-4A0FR8C

Electric-Power Co.: \_\_\_\_\_

Date: Feb. 17, 2017

Showing: Proposed Lateral Service Connection to 24 Fort Ave.

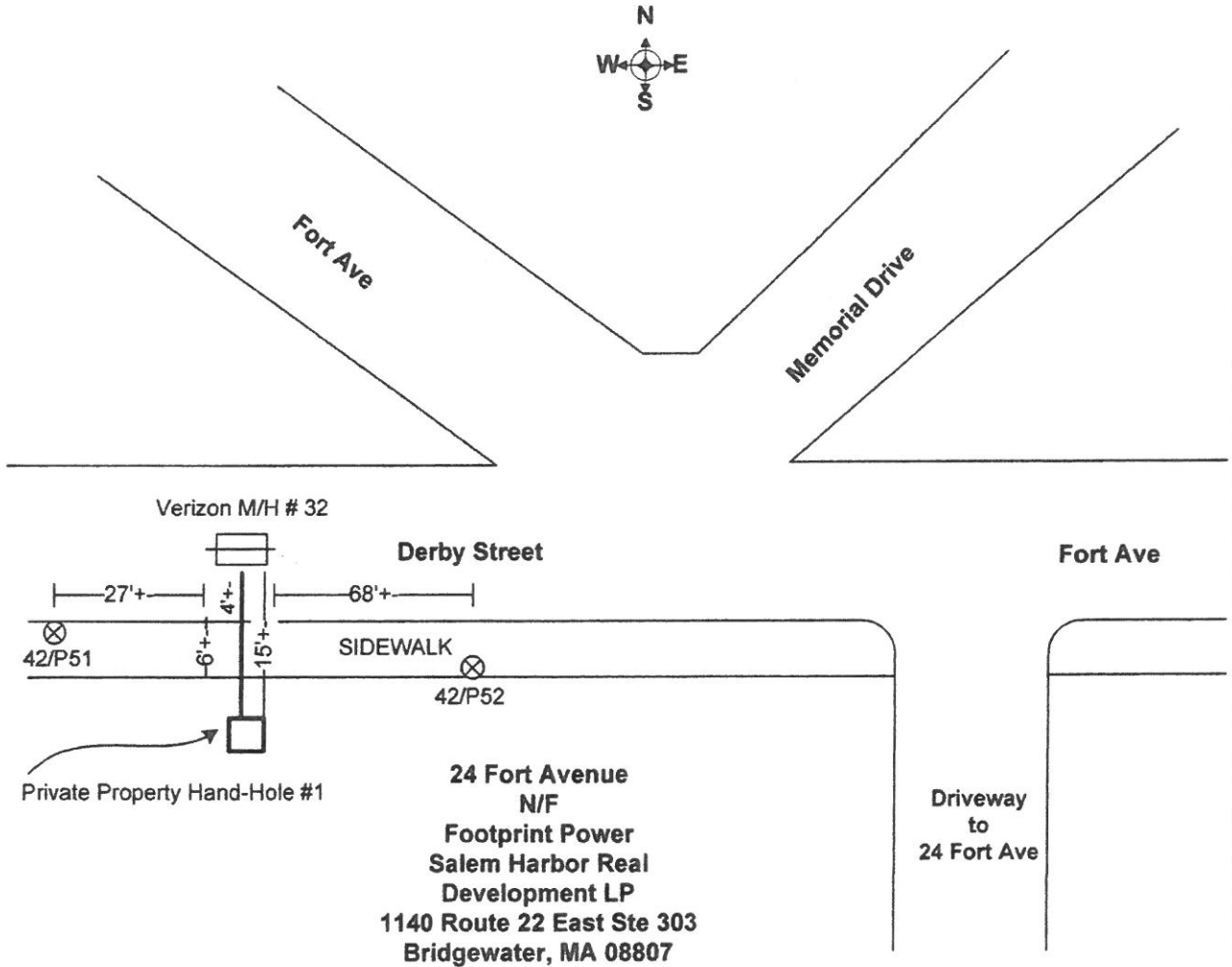

Prepared By: E. Bryan, Rights of Way Eng.

**LEGEND**

Checked By: S. Manseau, Eng.

- |                |  |                |  |
|----------------|--|----------------|--|
|                | - Existing J.O. Pole to Remain*                            |                | - Proposed J.O. Pole Location*                     |
|                | - Existing Verizon N.E. Inc. S.O. Pole to Remain**         |                | - Proposed Verizon N.E. Inc. S.O. Pole Location**  |
|                | - Existing Verizon N.E. Inc. Location to be Held Jointly   |                | - Existing Power Co. Location to be Held Jointly   |
|                | - Existing Verizon N.E. Inc. Pole Location to be Abandoned |                | - Existing Power Co. Pole Location to be Abandoned |
|                | - Fence  |                | - Existing J.O. Pole Location to be Abandoned*     |
|                | - Existing Verizon N.E. Inc. Manhole                       |                | - Proposed Verizon N.E. Inc. Hand-hole Location    |
| ..... VZ ..... | - Existing Verizon N.E. Inc. Buried Cable                  | —— VZ ——       | - Proposed Verizon N.E. Inc. Conduit Location      |
| —— VZ ——       | - Existing Verizon N.E. Inc. Conduit                       | ..... VZ ..... | - Proposed Verizon N.E. Inc. Buried Cable Location |

\*J.O. indicates Poles Jointly-Owned by Verizon N.E., Inc. & Power Co.  
\*\*S.O. indicates Poles Solely-Owned by Verizon N.E., Inc. or Power Co.

## **Ilene Simons**

---

**From:** John Giardi  
**Sent:** Wednesday, February 22, 2017 11:48 AM  
**To:** Ilene Simons  
**Subject:** RE: Petition from Verizon for conduit on Derby St. to 24 Fort Ave

Good morning Ilene sorry it took so long to get back to you I was out. I move approval at this time. City Electrician John Giardi.

**From:** Ilene Simons  
**Sent:** Tuesday, February 21, 2017 12:08 PM  
**To:** John Giardi; David Knowlton  
**Subject:** Petition from Verizon for conduit on Derby St. to 24 Fort Ave

Please commen prior to hearing date of 3/9/17.

Thank you,

Ilene Simons  
Assistant City Clerk  
Justice of the Peace  
93 Washington St.  
Salem, MA 01970  
(978) 745-9595 ext. 5614

**From:** [CityClerkMFP@salem.com](mailto:CityClerkMFP@salem.com) [mailto:[CityClerkMFP@salem.com](mailto:CityClerkMFP@salem.com)]  
**Sent:** Tuesday, February 21, 2017 1:03 PM  
**To:** Ilene Simons <[ISimons@Salem.com](mailto:ISimons@Salem.com)>  
**Subject:** Message from City Clerk MFP

Please note the Massachusetts Secretary of State's office has determined that most emails to and from municipal officials are public records. FMI please refer to: <http://www.sec.state.ma.us/pre/preidx.htm>  
Please consider the environment before printing this email.



**CITY OF SALEM, MASSACHUSETTS**

Kimberley Driscoll  
Mayor

March 9, 2017

To the City Council  
City Hall  
Salem, Massachusetts

Ladies and Gentlemen of the Council:

I re-appoint James f. Danworth of 16 Wentworth Drive Beverly Ma to serve as a Constable in the City of Salem for a term to expire February 1, 2020.

Very truly yours,

  
Kimberley Driscoll  
Mayor





# CITY OF SALEM

In City Council,  
March 9, 2017

## Ordered:

That the sum of Seven Hundred and Seventy Thousand Dollars (\$770,000.00) is hereby appropriated within the "Capital Outlay Renovation and Repair" account (20003-584617) to be expended for *the repairs of the MP Garage stairwells by the Traffic and Parking Department* in accordance with the recommendation of Her Honor the Mayor.



## CITY OF SALEM, MASSACHUSETTS

Kimberley Driscoll  
Mayor

March 9, 2017

Honorable Salem City Council  
Salem City Hall  
Salem, Massachusetts 01970

Ladies and Gentlemen of the City Council:

Enclosed please find an Order appropriating \$770,000 from our short-term capital fund to provide a share of the funding required for the reconstruction of the Museum Place Garage stairwells. The entire cost of this project is \$1,306,000, with \$536,000 of it coming from existing capital funds for garage maintenance and upgrades, including waterproofing.

As you may recall, last month we closed three of the four stairwells as water intrusion and regular use over time had created a public safety hazard in those stairwells. A fourth stairwell, which was found to be safe for use by inspectors, remains open, but will be addressed and upgraded as part of this project regardless. Over the past month, we conducted an expedited procurement and have now selected a contractor for this work.

During the work, there will always be at least one stairwell open to the public and safe for use, in addition to the elevators, which now run 24 hours a day. The contractor will be staging their work and, should you approve this Order on March 9, expect to have the first two stairwells finished by the end of July, with the second two stairwells then finished by the end of September. In addition to new stairs and stairwells, we are using this opportunity to repaint and add graphics and public art to the stairwells, to make them more welcoming and attractive.

Because of the necessity of these repairs and given the long lead time to order steel, I am requesting that the Council take up this appropriation for a vote at your regular meeting on March 9. We will be reaching out to you individually over the week ahead to try to address any questions you may have, so that you will have the information you need in advance of March 9.

As you know, the Museum Place Garage is heavily utilized by downtown workers, visitors, and residents who come downtown to conduct business, shop,

dine, or attend events. The City cannot allow these stairwells to remain in their current condition and we hope to advance this work as expeditiously as possible.

If funding is approved on March 9<sup>th</sup>, we will be able to execute a contract and issue a Notice to Proceed to the selected contractor allowing us to commence this important work in an expedited manner. I am happy to answer any questions you may have about this in advance of the March 9<sup>th</sup> meeting and I have asked senior staff members to reach out to councilors individually to discuss this request in more detail. I wholeheartedly support this appropriation and hope we can expedite this proposed work.

Very truly yours,

A handwritten signature in black ink that reads "Kim Driscoll". The signature is written in a cursive, flowing style.

Kimberley Driscoll  
Mayor  
City of Salem



## City of Salem, Massachusetts

Traffic & Parking Department  
120 Washington Street  
Salem, MA 01970  
[www.salem.com](http://www.salem.com)

Kimberley L. Driscoll, Mayor

Matthew Smith, Traffic & Parking Director

February 27, 2017

The Honorable Kimberley L. Driscoll  
Mayor of Salem  
93 Washington Street  
Salem, Massachusetts 01970

RE: Request for Funding: Parking Garage Improvements/Stairwells

Dear Honorable Mayor Driscoll:

This request is for a Council Order to provide CIP funding of \$770,000 for repair of the Museum Place Garage stairwells under the current FY CIP account 20003-584617.

As you know, in mid-January 2017 the City proactively hired a structural engineer to assess deteriorating conditions in the Museum Place Garage stairwells, evaluate complaints related to the four stairwells, and identify areas for FY18 future capital improvement requests. This evaluation revealed that the staircases have suffered from water infiltration, and as such, have begun to separate from the steel reinforcement. The water damage has resulted in concrete failure, and after further investigation by the structural engineer and the City's Building Inspector, the determination was made to close three out of the four staircases as a public safety precaution.

To address the urgent needs relating to the staircase conditions, the City, through an emergency procurement waiver granted by the Department of Capital Asset Management, hired an architect to draft specifications to address the problem. Specifications were completed, a targeted set of bids were vetted, and the most lowest qualified contractor was selected.

Due to the cost of steel and the complicated nature of the project repairs, the total price of this project and a related comprehensive engineering analysis of the garage will be \$1,416,000 million dollars. The City has existing funds available in a previously authorized garage capital line item. The existing funds will cover the cost of hiring a structural engineer to do a full evaluation of the garage, and a portion of the stairwell reconstruction. I am requesting the additional \$770,000 to cover the balance of the stairwell construction cost in order to complete the project as soon as possible.

Sincerely,

A handwritten signature in black ink, appearing to read "Matthew Smith".

Matthew Smith  
Traffic and Parking Director

**CITY OF SALEM**  
**Capital Outlay Expenditure Request Form**

To: MAYOR

From Department: Traffic & Parking      Date: February 27, 2017

---

**Expense Line To :** 20003-586017 - Equipment

**Amount:**

**Description:**

---

**Expense Line To :** 20003-584617 - Renovations & Repairs

**Amount:**

**Description:** Museum Place Garage stairwells improvement/reconstruction.



---

**For Finance Dept and Mayor's Use Only:**

City Council Approval

**Recommendation:**

Approved       Denied

  
Finance Director

\_\_\_\_\_  
Mayor

---

**Processed:**    **Date:** \_\_\_\_\_    **By:** \_\_\_\_\_

**CO #** \_\_\_\_\_    **JE#** \_\_\_\_\_    **Trans #** \_\_\_\_\_



# CITY OF SALEM

In City Council,

March 9, 2017

Ordered:

That the sum of Forty-Four Thousand Seven Hundred and Twenty-Six Dollars and Fifty-Five Cents (\$44,726.55) is hereby appropriated in the "Retirement Stabilization Fund-Vacation/Sick Leave Buyback" account (83113-5146) to be expended for the FY 2017 contractual buyback listed below in accordance with the recommendation of Her Honor the Mayor.

<b>Name</b>	<b>Department</b>	<b>Amount</b>
Robert Griffith	Fire	44,726.55
		<hr/> <b>44,726.55</b> <hr/>



CITY OF SALEM, MASSACHUSETTS

Kimberley Driscoll  
Mayor

March 9, 2017

To the City Council  
City Hall  
Salem, Massachusetts

Ladies and Gentlemen of the Council:

Enclosed herewith is a request for an appropriation of Forty-Four Thousand Seven Hundred and Twenty-Six Dollars and Fifty-Five Cents (\$44,726.55) from the "Retirement Stabilization Fund-Vacation/Sick Leave Buyback" account (83113-5146) to fund the retirement buyback costs to be expended for the employee listed below.

NAME	DEPARTMENT	AMOUNT
Robert Griffith	Fire	\$44,726.55

I recommend passage of the accompanying Order.

Very truly yours,  
*Kimberley Driscoll*

Kimberley Driscoll  
Mayor



CITY OF SALEM, MASSACHUSETTS

HUMAN RESOURCES
120 WASHINGTON STREET
TEL. (978) 745-9595 EXT. 5630
FAX (978) 745-7298

KIMBERLEY DRISCOLL
MAYOR

LISA B. CAMMARATA
DIRECTOR OF HUMAN RESOURCES

MEMORANDUM

TO: Sarah Stanton, Director of Finance
DATE: February 21, 2017
RE: Retirement Stabilization Fund

\*\*\*\*\*
Attached is a PAF for a former employee of the Salem Fire Department.

This former employee is contractually entitled to the following amount of sick and vacation buyback.

Robert Griffith

Table with 2 columns: Description and Amount. Rows include 24 vacation days @ \$304.41 per day (2016) for \$7,305.84, 24 vacation days @ \$304.41 per day (2017) for \$7,305.84, 3 vacation days @ \$296.99 per day (2015) for 890.97, and 90 sick days @ \$324.71 per day for \$29,223.90.

TOTAL DUE: \$44,726.55

In accordance with the July 2008 Policy, I am requesting you verify the availability of the funds from the Retirement Stabilization Fund, prepare the Council Order, and continue the process in order that my staff can input the information in MUNIS and issue payments to this former employee upon Council approval.

Thank you for your cooperation, and if you should have any questions, please do not hesitate to contact me.

Handwritten signature and initials 'LBC' in a circle.



**CITY OF SALEM  
APPROVAL-SICK DAYS/VACATION BUY-BACK**

From: Department Fire Date 1.30.17

Authorized Signature: [Signature]  
Department Head/City or Business Manager/School

NAME: Robert Griffith

CALCULATION

2016 <sup>DAYS</sup> VACATION HOURS # 24 @ \$ 304.41 = \$ 7,305.96 ~~84~~  
 <sup>DAYS</sup> SICK HOURS # 90 @ \$ 324.71 = \$ 29,223.84 ~~90~~  
 Fire to pay →  <sup>SMV</sup> PRO-RATED STIPENDS # 22 days @ \$ 13.25 = \$ 292.32  
 <sup>2017 VAC. DAYS</sup> OTHER # 24 @ \$ 304.41 = \$ 7,305.96 ~~84~~  
 <sup>2015 VAC. DAYS</sup> # 3 @ 296.99 = 890.97

Total Amount Due: \$ ~~45,019.05~~ 45,018.87  
Please attach corresponding PAF or other backup to this sheet.

Reason: Retirement

**For Human Resources's Use Only:**

- VACATION HOURS
- SICK HOURS
- PER ACCRUAL REPORT
- OTHER

45,018.87  
292.32 FIRE DEPT. TO PAY  

---

44,726.55

Org and Object: 83113 - 5144

**Recommendation:**

Approved

[Signature]  
HR Director/City or Superintendent/Schools



# CITY OF SALEM

In City Council,  
March 9, 2017

Ordered:

That the sum of Forty Thousand Dollars (\$40,000.00) is hereby appropriated from the "Fund Balance Reserved for Appropriation – Free Cash" account (1-3245) to the "Fire Medical-Active" Account (12202-5318) in accordance with the recommendation of Her Honor the Mayor.



**CITY OF SALEM, MASSACHUSETTS**  
Kimberley Driscoll  
Mayor

March 9, 2017

To the City Council  
City Hall  
Salem, Massachusetts

Ladies and Gentleman of the Council:

Enclosed herewith is a request to transfer Forty Thousand Dollars (\$40,000.00) from the "Fund Balance Reserved for Appropriation – Free Cash" account (1-3245) to the "Fire Medical-Active" Account (12202-5318).

This request is necessary to cover the costs of medical bills related to a line of duty injury.

I recommend passage of this accompanying order.

Sincerely,  

Kimberley Driscoll  
Mayor



# City of Salem, Massachusetts

## Fire Department

David W. Cody  
Chief  
(978) 744-6990  
dcody@salem.com

48 Lafayette Street  
Salem, Massachusetts 01970-3695  
Tel. (978) 744-1235  
Fax (978) 745-4646

Fire Prevention  
Bureau  
978-745-7777

March 2, 2017

Mayor Kimberley Driscoll  
City of Salem  
93 Washington Street  
Salem, MA 01970

Dear Mayor Driscoll,

Our active members medical account (12202-5318) has again been seriously impacted by a required surgery on a members knee. This is a physician documented job related injury. This procedure has been negotiated with the physicians office to 50% of the original surgical estimate.

The active members medical account 12201-5318 had a beginning balance of \$15,000. The revised budget to this account is \$35,780.00. At this time there is a balance of \$1,948.00 encumbered and \$416.00 available.

I am asking that a free cash allocation in the sum of \$40,000.00 be added to the line 12202-5318 Dental/Medical to cover the cost of the above described surgery.

Sincerely,

David W. Cody  
Chief of Department

**CITY OF SALEM - Finance Department**  
**Free Cash, W & S R/E, R/Res & Budget Transfer Requiring Council Approval**

From: 100 Fire Department      [Signature] Department Head Authorizing Signature      March 3, 2017 Date

**Budget or R/Res** Budget Amt: \_\_\_\_\_  
**Transfers** To: \_\_\_\_\_ Desc: \_\_\_\_\_ Curr Balance: \_\_\_\_\_  
(Org/Object)  
 From: \_\_\_\_\_ Desc: \_\_\_\_\_ Budget Amt: \_\_\_\_\_  
(\*Note - Please include letter to Mayor for Transfers from different Personnel & Non-personnel lines) Curr Balance: \_\_\_\_\_  
 Current Balance in Receipts Reserved Fund Above (if applicable) - \$ \_\_\_\_\_ Date: \_\_\_\_\_

**Free Cash or Retained Earnings (W/S)** To: 12202-5318 Desc: Dental/Med Budget Amt: \$15,000  
(Org/Object) Curr Balance: \$416.00  
 Please circle one

Amount Requested: \$ 40,000.00  
 Reason (Be Specific) medical bills related to a line of duty injury

*For Finance Department Use Only:*

Budget Transfer       Mayor Approval       City Council Approval  
 Free Cash Appropriation - City Council Approval - Gen Fund \$ 620,001.90  
Free Cash Balance NR  
 R/E Appropriation - Water \$ \_\_\_\_\_ R/E Balance       R/E Appropriation Sewer \$ \_\_\_\_\_ R/E Balance  
 Receipts Reserve - City Council Approval \$ \_\_\_\_\_ R/Res Fund Balance  
 Raise & Appropriate       Other \_\_\_\_\_

Recommendation:  Approved  Denied

[Signature]  
 Finance Director

\_\_\_\_\_  
 Mayor

Completed: Date: \_\_\_\_\_ By: \_\_\_\_\_ CO # \_\_\_\_\_ JE#: \_\_\_\_\_ Transfer #: \_\_\_\_\_



# CITY OF SALEM

In City Council,  
March 9, 2017

Ordered:

That the sum of Thirty-Five Thousand Dollars (\$35,000.00) is hereby appropriated within the "Capital Outlay Renovation and Repair" account (20003-584617) to be expended for *the repairs of pipes and valves in the pump house at the Olde Salem Greens by the Recreation Department* in accordance with the recommendation of Her Honor the Mayor.



**CITY OF SALEM, MASSACHUSETTS**  
Kimberley Driscoll  
Mayor

March 9, 2017

To the City Council  
City Hall  
Salem, Massachusetts

Ladies and Gentleman of the Council:

Enclosed herewith is a request to transfer Thirty-Five Thousand Dollars (\$35,000.00) within the "Capital Outlay Renovation and Repair" account (20003-584617).

This request is necessary to cover the costs for the repair of pipes and valves in the pump house at the Olde Salem Greens by the Recreation Department.

I recommend passage of this accompanying order.

Sincerely,

A handwritten signature in cursive script that reads "Kimberley Driscoll".

Kimberley Driscoll  
Mayor



## CITY OF SALEM, MASSACHUSETTS

PARK, RECREATION & COMMUNITY SERVICE

5 Broad Street, Salem MA 01970

Tel. (978) 744-0180/(978) 744-0924

Fax (978) 744-7225

pobrien@salem.com

Kimberley Driscoll  
MAYOR

Trish O'Brien  
Superintendent

March 3, 2017

Dear Mayor Driscoll,

This letter is to request \$35,000 from Capital Outlay money for the Pump House at Olde Salem Greens golf course.

Work will entail replacement and reconfiguring of the pipes, replacing the valves, and check valves, installing new butterfly valves and temperature sensors to prevent overheating of the pumps and motors.

The pipes are original from 1970 and are rotting from the inside out. Therefore pieces of rust from the pipes consistently clog the irrigation heads. There is also undue pressure on the electronic irrigation panel and excessive electricity use due to the pumps not shutting down when they should.

Sincerely,

A handwritten signature in black ink, appearing to read "Trish O'Brien", written over a large, light-colored scribble.

Trish O'Brien  
Superintendent  
Parks, Recreation, and Community Service



**CITY OF SALEM**  
**Capital Outlay Expenditure Request Form**

To: MAYOR

From Department: Olde Salem Greens Golf Course Park and Rec

Date: 3/2/17 

---

**Expense Line To :** 20003-586017 - Equipment

**Amount:**

**Description:** \_\_\_\_\_

**Expense Line To :** 20003-584617 – Renovations & Repairs

**Amount:**

**Description:** Pump House Pipe replacement  
\_\_\_\_\_

---

**For Finance Dept and Mayor's Use Only:**

City Council Approval

**Recommendation:**

Approved       Denied

  
\_\_\_\_\_  
**Finance Director**

\_\_\_\_\_  
**Mayor**

---

**Processed:**    **Date:** \_\_\_\_\_    **By:** \_\_\_\_\_

**CO #** \_\_\_\_\_    **JE#** \_\_\_\_\_    **Trans #** \_\_\_\_\_



# CITY OF SALEM

In City Council,  
March 9, 2017

## Ordered:

That the sum of Thirteen Thousand Two Hundred and Fifty-Five Dollars and Seventy-Five Cents (\$13,255.75) is hereby appropriated within the "Capital Outlay Equipment" account (20003-586017) to be expended for the purchase of *audio/visual equipment for CID interviews by the Police Department* in accordance with the recommendation of Her Honor the Mayor.



CITY OF SALEM, MASSACHUSETTS

Kimberley Driscoll  
Mayor

March 9, 2017

To the City Council  
City Hall  
Salem, Massachusetts

Ladies and Gentleman of the Council:

Enclosed herewith is a request to transfer Thirteen Thousand Two Hundred and Fifty-Five Dollars and Seventy-Five Cents (\$13,255.75) within the "Capital Outlay Equipment" account (20003-586017).

This request is necessary to cover the costs of for the purchase of audio/visual equipment for CID interviews by the Police Department.

I recommend passage of this accompanying order.

Sincerely,  
*Kimberley Driscoll*

Kimberley Driscoll  
Mayor



# City of Salem, Massachusetts Police Department Headquarters

CHIEF OF POLICE  
MARY E. BUTLER

February 27, 2017

Mayor Kimberley Driscoll  
Salem City Hall  
93 Washington Street  
Salem, MA 01970

Re: Interview Room Audio/Visual Equipment

Dear Mayor Driscoll:

It has been recently brought to the attention of the Criminal Investigation Division that the current audio/visual equipment to conduct interviews of suspect/offenders and victims/witnesses, as required by law, are not in compliance with federal and state standards. This new knowledge, left unaddressed, can put the department in a very difficult position on important major crimes when introducing the recordings in court.

The current equipment was installed in haste more than eight years ago when court decisions prompted the requirement of police departments to audio and visually record all interviews to assure that statements and confessions were clearly apparent and that no use of suggestion or duress was used. It's a logical conclusion based on some past cases around the country and clearly the technology exists for police departments to utilize.

With both the age of the current equipment and the non-compliance with some of the standards that require full visual of the room and the entry/exit doors, we are hoping to install a better audio/visual system that is user-friendly and compliant with all standards and regulations. We received a recent quote from Hunt's Photo and Visual through the assistance of Mr. Stan Goldberg, which documents the full cost of audio/visual equipment, activated lights outside the room when a recorded interview is in progress, and appropriate computer capacity for storage of all recordings. The total proposed cost is \$13,255.75. I am requesting consideration of Capital funds be directed to the completion of this project with your approval.

I am available at any time to answer any questions or concerns on this matter. Thank you in advance for your time and consideration.

Very truly,

Mary E. Butler  
Chief of Police

Enclosure (1)

Cc: Ms. Sarah Stanton, Finance Director

**CITY OF SALEM**  
**Capital Outlay Expenditure Request Form**

To: MAYOR

From Department: Police Date: 2/27/17

---

**Expense Line To :** 20003-586017 - Equipment

Amount: 13,255.75

Description: Replace A/V Equipment for CID.

**Expense Line To :** 20003-584617 - Renovations & Repairs

Amount:

Description:

---

---

**For Finance Dept and Mayor's Use Only:**

City Council Approval

**Recommendation:**

Approved  Denied

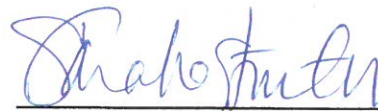

\_\_\_\_\_  
**Finance Director**

\_\_\_\_\_  
**Mayor**

---

Processed: Date: \_\_\_\_\_ By: \_\_\_\_\_

CO # \_\_\_\_\_ JE# \_\_\_\_\_ Trans # \_\_\_\_\_





WB HUNT CO. INC.  
 CORPORATE SALES  
 100 MAIN STREET  
 MELROSE, MA 02176  
 Phone (781) 462-2382

Invoice	I92525
Date	01-27-17
Store	IND
Type	****Quote****
Reprint	012717 15:43
A/R Account	SALPD

Bill to
SALEM POLICE DEPT 95 MARGIN ST ATTN: A/P SALEM, MA 01970

Ship to
SALEM POLICE DEPT 95 MARGIN ST DET. LT. STEPHEN BONA SALEM, MA 01970

Warehouse	P/O Number	Terms	Sold At	Bill to Phones	Ship to Phones
		N30	IND	(978) 744-1212	(978) 744-4104
Salesperson		Salesperson		Home	
3508 Stan G				Work	
				Cell	
				iT Ema	x
				T Ema	sbona@salempd.net

Item Number	Description	Brand	U/M	Order	Ship	List Price	Extended
AXSAV4D	AX-SAV4D 4OUT 12VDC	ADIII	EA	1	0	75.00	75.00
0EVDIR800VW	800T 960H 2.8-12M V DOM IR 12V	ADIII	EA	2	0	71.50	143.00
3130427878	BR1000G 1000VA TOWER UPS	APCII	EA	1	0	165.00	165.00
705110108652	KANGURU DVD DUP 1 TO 3 22X	KANGI	EA	1	0	419.95	419.95
WI100DLR	WI100DLR COVERT EARBUD SYSTEM	PMRLI	EA	1	0	625.00	625.00
LOUASK4KIT300	ASK4KIT300 VEIFACT MO	LOURI	EA	1	0	267.80	267.80
INSTRSPINTRM	INSTALL INTERVIEW ROOM	SEVCI	EA	1	0	800.00	800.00
CCPRE1HWUPG	CC PRM 1RM HRDWR UPG w/MONITOR	CRPKI	EA	1	0	9950.00	9950.00
CCFLAGSS1	START/STOP w/FLAGGING KIT 1RM	CRPKI	EA	1	0	750.00	750.00
2884520188	147045 C535R LED MARKER LIGHT	CLEAN	EA	2	0	30.00	60.00
9964	NO SHIPPING CHARGES!	MISCI	EA	1	0		
Sales Amount							13255.75
Sales Tax							.00
Freight							.00
Total							13255.75

Please Remit To: PO Box 842597 Boston, MA 02284

# CAPABILITIES

- ✓ Easiest to use solution
- ✓ Proven performance – used by over 1,300 local and federal agencies, including Naval Criminal Investigative Service (NCIS), Army CID, Air Force OSI, US Coast Guard, Boston PD, Seattle PD and Baltimore PD
- ✓ Among the first to enter the market with a law enforcement purpose-built Interview Recording Room Solution
- ✓ Backed by a team of in-house engineers to support product innovation
- ✓ Low maintenance with a 3 or 5 year warranty included
- ✓ Linux-based software provides security and stability
- ✓ Ongoing new features and enhancements provided with every system
- ✓ Software support – technical staff available to answer all software related questions via email or phone
- ✓ Our team takes pride in customer service and customer relationships
- ✓ We work with integrators for local installation and hands on product support

## CONTACT US

CaseCracker Sales Team  
sales@casecracker.com

CaseCracker Technical Support  
support@casecracker.com

www.casecracker.com

(303) 665-3962

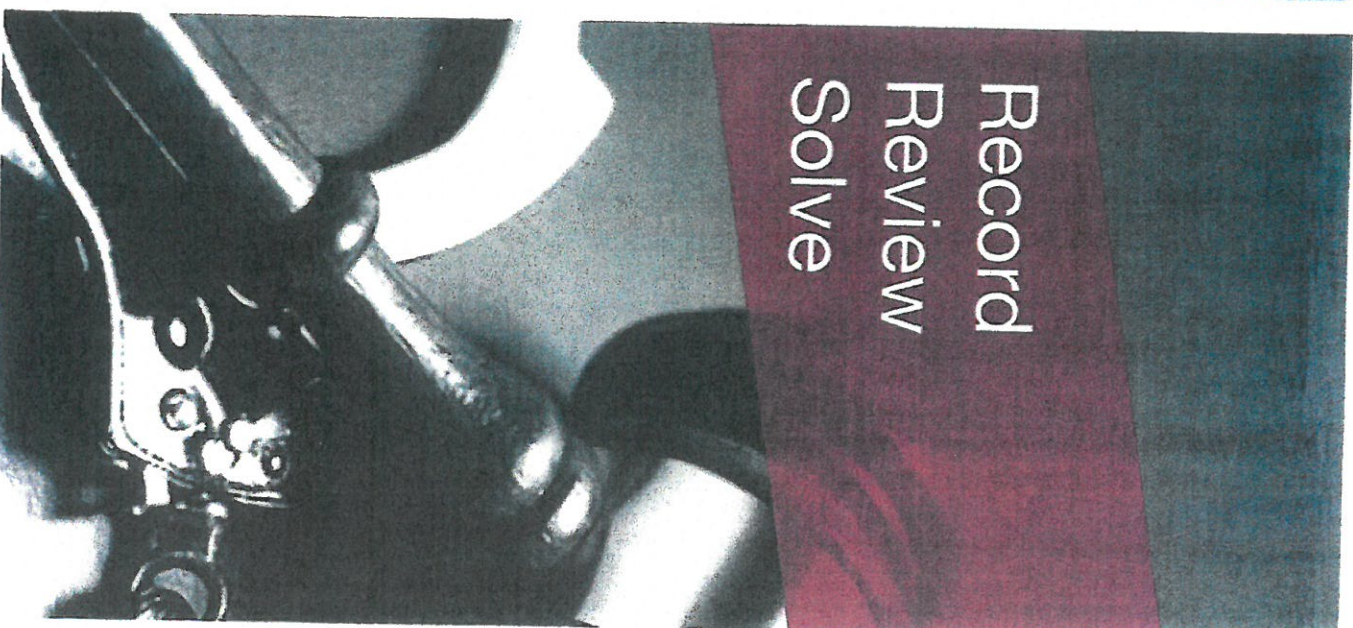

Record  
Review  
Solve



1380 Forest Park Cir, Ste 202  
Lafayette, CO 80026

**CASECRACKER**  
by Cardinal Peak





“Detectives have to deal with a lot... So CaseCracker’s ease of use has been the best feature so far.”  
 – John Neeley, Tucson PD, Arizona

## ABOUT

CaseCracker was designed specifically for recording and managing investigative interviews. Investigators can review a large number of interviews involving multiple subjects in a user-friendly and intuitive manner. With the easiest to use interface on the market, CaseCracker is the preferred solution among some of the most progressive federal agencies as well as state and local departments.

## FEATURES

- Initiate and end recordings with a single button
- Share interviews by burning them in a non-proprietary format to a DVD or exporting as a MP4 file
- Search based on interviewer, subject, time, case number, or text annotations
- Jump to any frame, annotation, or flag with a simple click or use of the slider bar

## BENEFITS

- Easiest to use interface on the market
- Increases conviction rates with video proof to present to the jury
- Playback and review features save valuable departmental resources
- Gives investigators flexibility to review interviews on their own schedule at their desktop computer



“CaseCracker is affordable, simple to use and cuts down on frivolous complaints of misconduct. It is a great tool to present in court.”  
 – Sgt. Ben Parisi, South Euclid PD, Ohio

### Record

Recording is initiated with one button remotely using a wall mounted switch, or at the monitoring station. Interviewers have the ability to use CaseCracker to record in two separate rooms simultaneously. All interviews are recorded and saved directly to the CaseCracker system.

### Review

Both live and previously recorded interviews can be securely streamed for simultaneous review by multiple users. Utilize play, pause, fast forward or rewind in multiple speeds to save time in the review process. Users can also add flags and annotations to mark important frames in the interview.

### Solve

After the interview, video, audio, still images and other reports can quickly be exported from CaseCracker in standard, non-proprietary formats. Users can easily burn excerpts of interviews to DVD for playback in the courtroom, allowing the jury to see the interview exactly as it was conducted.

363.665.3962

[www.casecracker.com](http://www.casecracker.com)

Lafayette, CO





# CITY OF SALEM

In City Council,  
March 9, 2017

Ordered:

Per MGL Chapter 44 Section 64 which allows for a municipality to pay for prior fiscal year invoices using current fiscal year appropriations by two-thirds vote of the City Council we request the sum of One Hundred and Fifty Dollars and Seventy-One Cents (\$150.71) of outstanding Fiscal Year 2016 Police Department invoices are hereby allowed to be paid from the Fiscal Year 2017 Police budget as listed below in accordance with the recommendation of Her Honor the Mayor.

Department	Vendor	Amount
Police	North Shore Medical Center	\$ 150.71
<b>Total</b>		<b>\$ 150.71</b>



CITY OF SALEM, MASSACHUSETTS  
Kimberley Driscoll  
Mayor

March 9, 2017

To the City Council  
City Hall  
Salem, Massachusetts

Ladies and Gentleman of the Council:

Enclosed herewith is a request to transfer One Hundred and Fifty Dollars and Seventy-One cents (\$150.71) of outstanding Fiscal Year 2016 Police Department invoices.

This request is necessary to cover the costs of unanticipated medical expenses from Fiscal Year 2016 out of the 2017 Medical Line item budget.

I recommend passage of this accompanying order.

Sincerely,

A handwritten signature in cursive script that reads "Kimberley Driscoll".

Kimberley Driscoll  
Mayor



# City of Salem, Massachusetts Police Department Headquarters

CHIEF OF POLICE  
MARY E. BUTLER

March 2, 2017

Mayor Kimberley Driscoll  
Salem City Hall  
93 Washington Street  
Salem, Massachusetts 01970

Dear Mayor Driscoll:

I am writing to request paying an unanticipated medical expense from Fiscal Year 2016 out of the 2017 Medical Line Item Budget. We would like to request authorization to pay a medical bill in the amount of \$150.71 for expenses incurred last fiscal year. I have attached a copy of the invoice for your review.

If you need any other information, please feel free to contact our office.

Thank you.

Sincerely,

Mary E. Butler  
Chief of Police

MEB:jc  
Enclosure



# CITY OF SALEM

In City Council,

Ordered:

March 9, 2017

To accept the donation(s) listed below totaling One Thousand and Fifty Dollars (\$1,050.00). These funds will be deposited into the Donation-No Place for Hate Fund 23691-4830 as listed in accordance with the recommendation of Her Honor the Mayor.

<b>From:</b>	<b>Fund Name</b>	<b>Org/Obj</b>	<b>Amount</b>
Notch Brewery	Don-No Place for Hate	23691-4830	\$ 1,050.00
<b>Total</b>			<b>\$ 1,050.00</b>



CITY OF SALEM, MASSACHUSETTS  
Kimberley Driscoll  
Mayor

March 9, 2017

Honorable Salem City Council  
Salem City Hall  
Salem, Massachusetts 01970

Ladies and Gentlemen of the City Council:

Enclosed herewith is a request to accept the following donation from Notch Brewery in the amount of One Thousand Fifty dollars (\$1,050.00). These funds will be deposited into the No Place for Hate account 23691-4830.

In order to accept the donation approval must be given by both the Mayor and City Council. I ask that the members of the City Council join with me in accepting these funds to be used towards the No Place for Hate.

Very truly yours,

*Kimberley Driscoll*  
Kimberley Driscoll  
Mayor



**CITY OF SALEM, MASSACHUSETTS**

Kimberley Driscoll  
Mayor

February 23, 2017

Dear Mayor Driscoll;

I am writing to request the acceptance of a \$1050.00 donation written to the Salem No Place for Hate Committee from Notch Brewery (Notch Tap Room, LLC).

Please accept the \$1050.00 for deposit into the Salem No Place for Hate donation account number 23691-4830. The money will be used to help sponsor community related event and social justice work done through the committee.

Sincerely,

A handwritten signature in black ink, appearing to read "Jeffrey Cohen", is written over a horizontal line.

Jeffrey Cohen  
Chair

No Place for Hate Committee



# CITY OF SALEM

In City Council,

Ordered:

March 9, 2017

To accept the donation(s) listed below totaling One Thousand Dollars (\$1,000.00). These funds will be deposited into the Veterans Donation Fund 23671-4830 as listed in accordance with the recommendation of Her Honor the Mayor.

<b>From:</b>	<b>Fund Name</b>	<b>Org/Obj</b>	<b>Amount</b>
Kevin Miller-CCB Union	Veterans Donation Fund	23671-4830	\$ 1,000.00
<b>Total</b>			<b>\$ 1,000.00</b>



CITY OF SALEM, MASSACHUSETTS

Kimberley Driscoll  
Mayor

March 9, 2017

Honorable Salem City Council  
Salem City Hall  
Salem, Massachusetts 01970

Ladies and Gentlemen of the City Council:

Enclosed herewith is a request to accept the following donation from Kevin Miller – CCB Union in the amount of One Thousand dollars (\$1,000.00). These funds will be deposited into the Veterans Donation Fund 23671-4830.

In order to accept the donation approval must be given by both the Mayor and City Council. I ask that the members of the City Council join with me in accepting these funds to be used towards the Veterans.

Very truly yours,

*Kimberley Driscoll*

Kimberley Driscoll  
Mayor





KIMBERLEY DRISCOLL  
MAYOR

# City of Salem, Massachusetts

Department of Veteran Services

Director of Veteran Services

Kim F. Emerling

February 27, 2017

ATTN: Kimberly Driscoll, Mayor

Dear Mayor Driscoll,

The Salem Veterans Office has been fortunate enough to be the recipient of a donation of \$1,000. This generous donation is from Kevin Miller, a field representative for CCB, one of the unions working at the Footprint Power Plant. The men and women of CCB recently held a fundraiser and decided that the veterans of Salem would be the benefactors.

Please forward this donation to the Salem City Council at your earliest convenience. *fund 23671-4830*

In order to deposit it to our donation account, it needs your approval. Thank you for your immediate attention to this matter.

Sincerely,

Kim F. Emerling



## CITY OF SALEM, MASSACHUSETTS

Kimberley Driscoll  
Mayor

March 9, 2017

Honorable Salem City Council  
Salem City Hall  
Salem, Massachusetts 01970

Ladies and Gentlemen of the City Council:

I am very pleased to write to inform you that the City has recently received \$1.1 million in debt savings thanks to a recent bond refinancing. Roughly half of these savings are on general fund debt and the remainder in water and sewer debt. These savings will be directly applied to the FY2018 debt payment amounts that will appear in the forthcoming FY2018 budget, saving Salem taxpayers a considerable amount in the upcoming year.

As you may know, three years ago, Salem's bond rating was upgraded by Standard & Poor's to AA, our highest rating ever. We have maintained that rating since then and the agency, in their most recent report, stated:

We view the city's management as strong, with good financial policies and practices... Salem regularly monitors revenues and expenditures, and makes conservative budget assumptions based on a five-year trend. The city council and mayor engage in regular budget surveillance and receive monthly budget-to-actual and investment reports... The city also has a multiyear financial plan that identifies future issues, leading to revenue and expenditure decisions with a long-term perspective. Structural balance is a clear goal in the decision-making process. Salem has an investment policy, debt policy, and a reserve policy... Total governmental fund debt service is 2.7% of total governmental fund expenditures [and] overall net debt is low at 1.5% of market value, which is in our view a positive credit factor.

This rating affirmation reflects our dedication to policies that foster positive economic growth, stable financial management practices, and sustainable and transparent budgeting. Since 2006 we have implemented professional financial management and I am proud that in that time the amount of debt service in our budget dropped by 19% and the share of our budget that is our debt payment was cut in half. We were able to accomplish this by leveraging outside funds, such as grants, and by being responsible, thoughtful, and prudent with tax dollars.

Not only do our sound fiscal practices ensure public funds are being managed to the highest standards and with complete transparency, they also allow us to realize financial gains. In this case, a recent refinancing of our existing infrastructure debt, at the lower interest rates accessible to us through our excellent bond rating, has realized us \$1.1 million in newly available funds that we can apply to reduce our debt overall.

This is not the first time we have realized proceeds from a bond refinancing, however given the substantial amount of savings and the positive impact they will have on our FY2018 budget-setting process, I wanted you to be aware of this good news. None of this could happen without a strong working relationship between the administration and the City Council, along with a shared, collective commitment to work together to improve our City's financial health.

Very truly yours,

A handwritten signature in black ink that reads "Kimberley Driscoll". The signature is written in a cursive, flowing style.

Kimberley Driscoll  
Mayor  
City of Salem

PETITION OF COMCAST FOR LOCACTION FOR CONDUITS AND MANHOLES

To the City Council for the City of Salem, Massachusetts:

Respectfully represents Comcast of Massachusetts I, Inc., a company incorporated for the distribution of telecommunications services, that it desires to construct a line for such telecommunications under the public way or ways hereinafter specified.

**29 Traders Way, Salem, MA:** From existing Comcast manhole on Traders Way place (1) 4" PVC communication conduit 456' +/- in an Easterly direction to the property line of 29 Traders Way and continue conduit placement another 543' +/- in a Northeasterly direction on private property to the rear of the building located at 29 Traders Way.

Wherefore, your petition prays that, after due notice and hearing as provided by law, the City Council may by Order grant your petitioner permission to construct, and a location for, such a line of conduits and manholes with the necessary wires and cables therein, said conduits and manholes to be located, substantially as shown on the plan made by Comcast of Massachusetts I, Inc. dated March 6, 2017, and filed here with, under the following public way or ways of said City of Salem.

Comcast Cable Corporation

By: Wayne Henshaw

Wayne Henshaw  
Fiber Project Coordinator

Dated this March 6, 2017

City of Salem Massachusetts

Received and filed \_\_\_\_\_, 2017

\_\_\_\_\_



PROPOSED CABLE INSTALLATION  
AT  
29 TRADERS WAY  
SALEM, MA



LOCUS  
NTFS

INDEX OF DRAWING	
SHEET NO.	DESCRIPTION
01	COVER SHEET
02	CIVIL PLAN 01
03	CIVIL PLAN 02
04	DETAILS AND GENERAL NOTES

**AXIS**  
ENGINEERING GROUP  
1900 West Park Dr. Suite 165  
Westboro, MA 01581  
(508) 870-7221 www.axisengr.com

March 6, 2017







**GENERAL NOTES**

1. THE LOCATION OF EXISTING UNDERGROUND UTILITIES ARE SHOWN IN AN APPROXIMATE WAY ONLY AND HAVE NOT BEEN INDEPENDENTLY VERIFIED BY THE OWNER OR ITS REPRESENTATIVE. THE CONTRACTOR SHALL DETERMINE THE EXACT DAMAGES WHICH MIGHT BE OCCURRED BY THE CONTRACTOR'S FAILURE TO EXACTLY LOCATE AND RESERVE ANY AND ALL UNDERGROUND UTILITIES.
2. WHERE AN EXISTING UTILITY IS FOUND TO CONFLICT WITH THE PROPOSED WORK, THE LOCATION, DEPTH AND SIZE OF THE CONFLICT TO THE ENGINEER FOR RESOLUTION OF THE CONFLICT.
3. THE CONTRACTOR SHOULD MAINTAIN A SEPARATION OF 24 INCHES MIN. WHEN CROSSING EXISTING WATER FACILITIES, AND ANY OTHER PRIVATE UTILITIES BY THE UTILITY COMPANY.
4. THE CONTRACTOR SHALL NOT DISTURB PUBLIC UTILITY AND SERVICES.
5. THE CONTRACTOR SHALL MAINTAIN THE EXISTING UTILITIES IN THE CONTRACTOR'S OPERATIONS SHALL BE RESTORED BY THE CONTRACTOR TO THEIR ORIGINAL CONDITION AT NO EXPENSE TO THE OWNER.
6. THE CONTRACTOR SHALL BE RESPONSIBLE FOR RELOCATING AND MAINTAINING TEMPORARY RESURFACING AND/OR CHANGING FOR ALL EXCAVATIONS IN PAVED STREETS AND SIDEWALKS UNTIL PERMANENT RESURFACING IS COMPLETE.
7. JOINTS BETWEEN ADJACENT CONCRETE SIDEWALKS AND PAVEMENT AND SAW CUT EXISTING PAVEMENT SHALL BE SEALED WITH BITUMEN AND BACK FINISH.
8. THE CONTRACTOR SHALL PROTECT ALL EXISTING UTILITY LINES THAT BECOME EXPOSED DUE TO EXCAVATION REQUIRED TO INSTALL THE PROPOSED WORK.
9. THE CONTRACTOR SHALL REPAIR ALL DETERIORATED TRAFFIC SIGNAL LIGHT FIXTURES TO GOOD WORKING CONDITION AS REQUIRED BY THE CITY OF ALBUQUERQUE.
10. ALL EXCAVATIONS SHALL BE PROTECTED BY SAFETY BARRIERS AND SIGNAGE THAT HAVE BEEN ESTABLISHED FROM AVAILABLE INFORMATION AND THEIR EXACT LOCATION ARE NOT GUARANTEED.
11. ALL PORTING STAKE, CHAIN, CUT AND TAPING CONNECTIONS AND PRIVATE PROPERTY LINES HAVE BEEN ESTABLISHED BY EXCAVATION OR OPERATIONS OF THE CONTRACTOR WITH SIMILAR COLOR AND SIZE THERMOPLASTIC MARKINGS.
12. THE CONTRACTOR SHALL REPAIR ALL PAVEMENT MARKINGS IN THEIR ENTIRETY THAT HAVE BEEN DAMAGED BY TRENCH EXCAVATION OR OPERATIONS OF THE CONTRACTOR WITH SIMILAR COLOR AND SIZE THERMOPLASTIC MARKINGS.

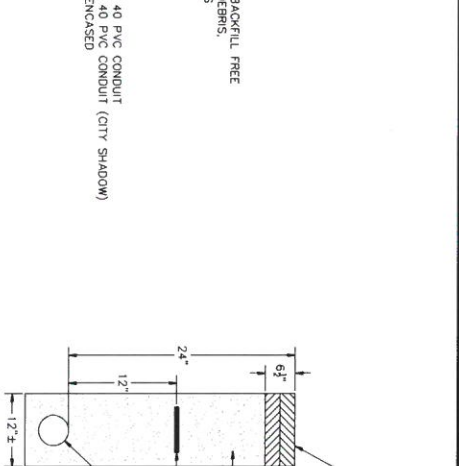
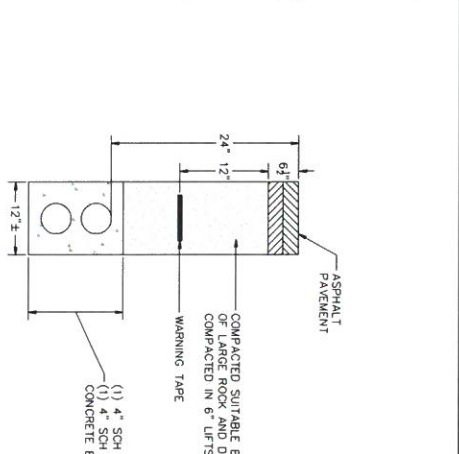

**ROADWAY PATCH AND DUCT BANK INSTALLATION DETAIL**  
N.T.S.

**ROADWAY PATCH AND DUCT BANK INSTALLATION DETAIL**  
N.T.S.

- TRENCH DETAIL NOTES:**
1. 24" MAXIMUM FROM TOP OF CONDUIT TO SURFACE.
  2. 12" FROM TOP OF CONDUIT TO METALLIC WARNING TAPE PLACED ABOVE.
  3. REPAIR SIDEWALKS AND WALKWAYS WITH SAME MATERIALS AS EXISTING.

- TRENCH DETAIL NOTES:**
1. 24" MAXIMUM FROM TOP OF CONDUIT TO SURFACE.
  2. 12" FROM TOP OF CONDUIT TO METALLIC WARNING TAPE PLACED ABOVE.
  3. REPAIR SIDEWALKS AND WALKWAYS WITH SAME MATERIALS AS EXISTING.

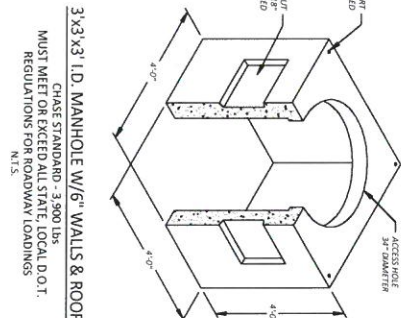
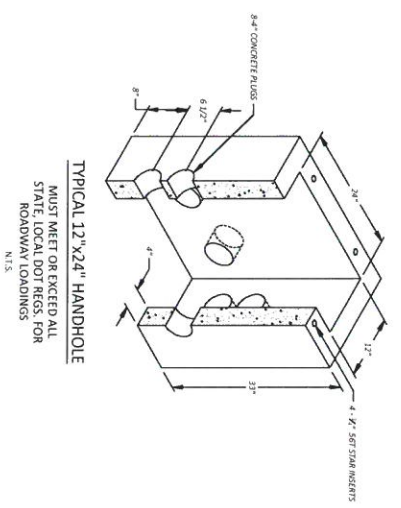

**LEGEND**

1	ELECTRIC POLE	2	STREET LIGHT
3	WATER POLE	4	TELEPHONE
5	SEWER MAIN	6	CATV MAIN
7	SEWER MANHOLE	8	COMBINATION MANHOLE
9	SEWER VALVE	10	SEWER CLEANOUT
11	SEWER CLEANOUT	12	SEWER CLEANOUT
13	SEWER CLEANOUT	14	SEWER CLEANOUT
15	SEWER CLEANOUT	16	SEWER CLEANOUT
17	SEWER CLEANOUT	18	SEWER CLEANOUT
19	SEWER CLEANOUT	20	SEWER CLEANOUT
21	SEWER CLEANOUT	22	SEWER CLEANOUT
23	SEWER CLEANOUT	24	SEWER CLEANOUT
25	SEWER CLEANOUT	26	SEWER CLEANOUT
27	SEWER CLEANOUT	28	SEWER CLEANOUT
29	SEWER CLEANOUT	30	SEWER CLEANOUT
31	SEWER CLEANOUT	32	SEWER CLEANOUT
33	SEWER CLEANOUT	34	SEWER CLEANOUT
35	SEWER CLEANOUT	36	SEWER CLEANOUT
37	SEWER CLEANOUT	38	SEWER CLEANOUT
39	SEWER CLEANOUT	40	SEWER CLEANOUT
41	SEWER CLEANOUT	42	SEWER CLEANOUT
43	SEWER CLEANOUT	44	SEWER CLEANOUT
45	SEWER CLEANOUT	46	SEWER CLEANOUT
47	SEWER CLEANOUT	48	SEWER CLEANOUT
49	SEWER CLEANOUT	50	SEWER CLEANOUT
51	SEWER CLEANOUT	52	SEWER CLEANOUT
53	SEWER CLEANOUT	54	SEWER CLEANOUT
55	SEWER CLEANOUT	56	SEWER CLEANOUT
57	SEWER CLEANOUT	58	SEWER CLEANOUT
59	SEWER CLEANOUT	60	SEWER CLEANOUT
61	SEWER CLEANOUT	62	SEWER CLEANOUT
63	SEWER CLEANOUT	64	SEWER CLEANOUT
65	SEWER CLEANOUT	66	SEWER CLEANOUT
67	SEWER CLEANOUT	68	SEWER CLEANOUT
69	SEWER CLEANOUT	70	SEWER CLEANOUT
71	SEWER CLEANOUT	72	SEWER CLEANOUT
73	SEWER CLEANOUT	74	SEWER CLEANOUT
75	SEWER CLEANOUT	76	SEWER CLEANOUT
77	SEWER CLEANOUT	78	SEWER CLEANOUT
79	SEWER CLEANOUT	80	SEWER CLEANOUT
81	SEWER CLEANOUT	82	SEWER CLEANOUT
83	SEWER CLEANOUT	84	SEWER CLEANOUT
85	SEWER CLEANOUT	86	SEWER CLEANOUT
87	SEWER CLEANOUT	88	SEWER CLEANOUT
89	SEWER CLEANOUT	90	SEWER CLEANOUT
91	SEWER CLEANOUT	92	SEWER CLEANOUT
93	SEWER CLEANOUT	94	SEWER CLEANOUT
95	SEWER CLEANOUT	96	SEWER CLEANOUT
97	SEWER CLEANOUT	98	SEWER CLEANOUT
99	SEWER CLEANOUT	100	SEWER CLEANOUT

**EXISTING UTILITIES TO BE ABANDONED AND NOT WARRANTED TO BE CORRECT. THE CONTRACTOR SHALL VERIFY THE LOCATION AND DEPTH OF ALL EXISTING UTILITIES BEFORE BEGINNING ANY EXCAVATION.**

**NOTE:** ALL UTILITIES TO BE ABANDONED AND NOT WARRANTED TO BE CORRECT. THE CONTRACTOR SHALL VERIFY THE LOCATION AND DEPTH OF ALL EXISTING UTILITIES BEFORE BEGINNING ANY EXCAVATION.

1	PROPOSED CONDUIT
2	PROPOSED CONDUIT
3	PROPOSED CONDUIT
4	PROPOSED CONDUIT
5	PROPOSED CONDUIT
6	PROPOSED CONDUIT
7	PROPOSED CONDUIT
8	PROPOSED CONDUIT
9	PROPOSED CONDUIT
10	PROPOSED CONDUIT
11	PROPOSED CONDUIT
12	PROPOSED CONDUIT
13	PROPOSED CONDUIT
14	PROPOSED CONDUIT
15	PROPOSED CONDUIT
16	PROPOSED CONDUIT
17	PROPOSED CONDUIT
18	PROPOSED CONDUIT
19	PROPOSED CONDUIT
20	PROPOSED CONDUIT
21	PROPOSED CONDUIT
22	PROPOSED CONDUIT
23	PROPOSED CONDUIT
24	PROPOSED CONDUIT
25	PROPOSED CONDUIT
26	PROPOSED CONDUIT
27	PROPOSED CONDUIT
28	PROPOSED CONDUIT
29	PROPOSED CONDUIT
30	PROPOSED CONDUIT
31	PROPOSED CONDUIT
32	PROPOSED CONDUIT
33	PROPOSED CONDUIT
34	PROPOSED CONDUIT
35	PROPOSED CONDUIT
36	PROPOSED CONDUIT
37	PROPOSED CONDUIT
38	PROPOSED CONDUIT
39	PROPOSED CONDUIT
40	PROPOSED CONDUIT
41	PROPOSED CONDUIT
42	PROPOSED CONDUIT
43	PROPOSED CONDUIT
44	PROPOSED CONDUIT
45	PROPOSED CONDUIT
46	PROPOSED CONDUIT
47	PROPOSED CONDUIT
48	PROPOSED CONDUIT
49	PROPOSED CONDUIT
50	PROPOSED CONDUIT
51	PROPOSED CONDUIT
52	PROPOSED CONDUIT
53	PROPOSED CONDUIT
54	PROPOSED CONDUIT
55	PROPOSED CONDUIT
56	PROPOSED CONDUIT
57	PROPOSED CONDUIT
58	PROPOSED CONDUIT
59	PROPOSED CONDUIT
60	PROPOSED CONDUIT
61	PROPOSED CONDUIT
62	PROPOSED CONDUIT
63	PROPOSED CONDUIT
64	PROPOSED CONDUIT
65	PROPOSED CONDUIT
66	PROPOSED CONDUIT
67	PROPOSED CONDUIT
68	PROPOSED CONDUIT
69	PROPOSED CONDUIT
70	PROPOSED CONDUIT
71	PROPOSED CONDUIT
72	PROPOSED CONDUIT
73	PROPOSED CONDUIT
74	PROPOSED CONDUIT
75	PROPOSED CONDUIT
76	PROPOSED CONDUIT
77	PROPOSED CONDUIT
78	PROPOSED CONDUIT
79	PROPOSED CONDUIT
80	PROPOSED CONDUIT
81	PROPOSED CONDUIT
82	PROPOSED CONDUIT
83	PROPOSED CONDUIT
84	PROPOSED CONDUIT
85	PROPOSED CONDUIT
86	PROPOSED CONDUIT
87	PROPOSED CONDUIT
88	PROPOSED CONDUIT
89	PROPOSED CONDUIT
90	PROPOSED CONDUIT
91	PROPOSED CONDUIT
92	PROPOSED CONDUIT
93	PROPOSED CONDUIT
94	PROPOSED CONDUIT
95	PROPOSED CONDUIT
96	PROPOSED CONDUIT
97	PROPOSED CONDUIT
98	PROPOSED CONDUIT
99	PROPOSED CONDUIT
100	PROPOSED CONDUIT

**AXIS ENGINEERING GROUP**

**Comcast**

**DETAILS AND GENERAL NOTES**

21 AUGUST 2017

SCALE: AS SHOWN

DATE: 08/21/17



March 6, 2017

Ms. Cheryl A. LaPointe  
Salem City Clerk  
City Hall  
93 Washington Street  
Salem, MA 01970

Dear Ms. LaPointe:

Comcast of Massachusetts I, Inc. would like to request a hearing with the Salem City Council for a grant of location. The purpose of the grant of location request is to install (1) 4" PVC communication conduit 456' +/- in an Easterly direction from an existing Comcast manhole on Traders Way to the property line of 29 Traders Way and continue conduit placement another 543' +/- in a Northeasterly direction on private property to the rear of the building located at 29 Traders Way

Please feel free to call me with any questions. I can be reached at (978)-758-0233.

Sincerely,

*Wayne Henshaw*

Wayne Henshaw  
Comcast Cable Corporation  
Fiber Project Coordinator

Enclosures

March 2, 2017

***By UPS and Email***

City Clerk's Office  
Salem City Hall  
93 Washington Street  
Salem, MA 01970  
clapointe@salem.com

***Re Special Variance Request for National Grid Project***

To the City Councilors:

I am writing on behalf of New England Power Company d/b/a National Grid ("National Grid" or the "Company") to request that you set for agenda at the City Council meeting on Thursday, March 9, 2017 the Company's request for City Council approval for a special variance to be issued by the city building inspector, pursuant to the Salem, Massachusetts Code of Ordinances, Part III, Chapter 22 ("Salem Noise Ordinance"), Section 22-2(5)(a) and (c), for work to be conducted on Sunday, June 4, 2017.

The Salem Noise Ordinance prohibits the operation of tools or equipment used in construction or demolition work between the hours of 5:00 p.m. and 8:00 a.m. the following day on weekdays and Saturdays or at any time on Sundays or holidays, where the sound therefrom creates a noise disturbance across a residential real property boundary. Salem Noise Ordinance Sec. 22-2(5)(a). Excepted from that prohibition are the emergency work of public service utilities, or special variances issued by the building inspector. *Id.* The Salem Noise Ordinance goes on to provide that no special variance shall be granted by the building inspector for work on Sundays without prior approval of the city council. Salem Noise Ordinance Sec. 22-2(5)(c).

In an effort to improve the reliability of its system, National Grid will replace an existing transmission structure and a load break switch on its property located at the end of March Street Court. The new structure will be smaller than the structure being replaced. Customers will not experience interruptions in service as a result of the work being performed during this time.

The timeframe within which National Grid may complete this work, however, is affected by the outage availability for the line in coordination with other projects in the Greater Boston area. Based on such outage availability, National Grid expects to conduct this work from Tuesday, May 30, 2017 to Tuesday, June 6, 2017 beginning at 7:00 a.m. and concluding at 5:00 p.m. daily.

The Company sought and received from Mr. Thomas St. Pierre, the building inspector for the City of Salem, a special variance for the work between the hours of 7:00 a.m. and 8:00 a.m. on weekdays and Saturdays, pursuant to Salem Noise Ordinance Sec. 22-2(5)(a). That special

City Clerk's Office  
Salem City Hall  
March 2, 2017

work permit is attached hereto. As Mr. St. Pierre states in that permit, he will notify the Police Department in accordance with Salem Noise Ordinance Sec. 22-2(5)(a).

The Company is further seeking a special variance from the building inspector for the work to be conducted on Sunday, June 4, 2017, pursuant to Salem Noise Ordinance Sec. 22-2(5)(a). As required by Salem Noise Ordinance Sec. 22-2(5)(c), National Grid is seeking this City Council's prior approval of the special variance for that Sunday work.

National Grid's request for a variance of the terms of the Salem Noise Ordinance for the Sunday work is not contrary to the public interest and owes to conditions peculiar to this project. As described above, the timeframe within which National Grid may complete this work is affected by outage availability for the line in coordination with other projects in the Greater Boston area. Accordingly, the variance request is not a result of any actions by National Grid. To the contrary, a literal enforcement of the Salem Noise Ordinance would result in unnecessary and undue hardship on the Company and its customers, as it would be unable to timely improve the reliability of its system by replacing the existing transmission structure and load break switch on its property located at the end of March Street Court.

National Grid expects any noise disturbance from this work to be minimal, and likely will come solely from bucket trucks, a crane, pickup trucks, and wire pulling equipment. This work will not involve the operation of drilling and/or blasting equipment, rock crushing machinery, pile driving, or jack hammers.

The Company reached out to neighboring residences on March Street Court by letter dated February 17, 2017 regarding the work and proposed timeframe. To-date, no neighbor has contacted the Company or otherwise raised any questions or concerns with the Company about the proposed construction hours for the work or the noise to be generated from this work.

We look forward to the March 9, 2017 City Council meeting, and respectfully request that the City Council provide at that meeting its prior approval for special variance by the building inspector for the Sunday, June 4, 2017 National Grid work at its property at the end of March Street Court, pursuant to Salem Noise Ordinance Sec. 22-2(5)(c).

Sincerely,



Marisa L. Pizzi

Enclosure

cc: Thomas St. Pierre, Salem Building Inspector  
Lisa A. Gilbreath, National Grid Seconded Counsel  
Robert Reis, National Grid Project Manager

**Thomas St. Pierre**

---

**From:** Thomas St. Pierre  
**Sent:** Monday, February 27, 2017 10:14 AM  
**To:** 'Lisa A. Gilbreath'  
**Subject:** Special work permit March Street substation

Lisa Gilbreath  
Pierce Atwood L.L.P.  
Merrills Wharf  
254 Commercial street  
Portland .Maine 04101

Dear Ms. Gilbreath,

I have received your request, on behalf of National Grid, for a Special work permit for the sub-station located on March street. I would also agree that this work is likely exempt from our noise ordinance. However, I am granting you Special work permit to conduct work from Monday through Saturdays from (0700) 7:00 A.M to (2000) 8:00 P.M for the dates of Tuesday May 30<sup>th</sup> through Tuesday June 6<sup>th</sup>. You are also correct that the request for Sundays must go through our City Council. If you have any questions ,please let me know. I will copy our Police Department this permit in case they receive any complaints.

Sincerely,



Thomas St.Pierre

## ARTICLE I. IN GENERAL

### Sec. 22-1. Certain noises prohibited generally.

(a) It shall be unlawful for any person to make, continue, or cause to be made or continued any loud, unnecessary or unusual noise or any noise which:

- (1) Endangers or injures the safety or health of humans or animals;
- (2) Annoys or disturbs a reasonable person of normal sensitivities; or
- (3) Endangers or injures personal or real property, which noise shall be termed a "noise disturbance" for the purposes of this chapter.

(b) Noncommercial public speaking and public assembly activities conducted on any public space or public right-of-way shall be exempt from the operation of this section.

(Code 1973, § 16½-1)

### Sec. 22-2. Noises enumerated.

The following acts, among others, and the causing thereof are declared to be loud, disturbing and unnecessary noises and to be in violation of this chapter, but such enumeration shall not be deemed to be exclusive:

- (1) *Radios, television sets, musical instruments and similar devices.* Operating, playing or permitting the operation or playing of any radio, television, phonograph, drum, musical instrument, sound amplifier or similar device which produces, reproduces or amplifies sound:
  - a. Between the hours of 11:00 p.m. and 7:00 a.m. the following day in such manner as to create a noise disturbance as set out in section 22-1 across a real property boundary, except for activities open to the public and for which a permit has been issued by an appropriate authority in the city.
  - b. In such a manner as to create a noise disturbance at 50 feet (15 meters) from such device, when operated in

or on a motor vehicle on a public right-of-way or public space or in a boat on public waters.

- c. In such a manner as to create a noise disturbance to any person other than the operator of a device, when operated by any passenger on a common carrier.

This subsection shall not apply to noncommercial spoken language covered under section 22-1.

- (2) *Loudspeakers/public address systems.*
  - a. Using or operating for any noncommercial purposes any loudspeaker, public address system, or similar device between the hours of 10:00 p.m. and 8:00 a.m. the following day, such that the sound therefrom creates a noise disturbance across a residential real property boundary or within a noise sensitive zone.
  - b. Using or operating for any commercial purpose any loudspeaker, public address system or similar device such that the sound therefrom creates a noise disturbance across a real property boundary between the hours of 6:00 p.m. and 10:00 a.m. the following day on a public right-of-way or public space.
- (3) *Animals and birds.* Owning, possessing or harboring any animal or bird which frequently or for continued duration makes sounds which create a noise disturbance across a residential real property boundary.
- (4) *Loading and unloading, manufacturing activities.* Loading and unloading of boxes, crates, and containers at all commercial and/or retail establishments. Loading, unloading or other handling of boxes, crates, containers or building materials or similar objects and the engaging in manufacturing activities between the hours of 11:00 p.m. and 7:00 a.m. the following



in such a manner as to cause a noise disturbance across a residential real property boundary.

(5) **Construction and blasting**

a. **Construction.** Operating or permitting the operation of tools or equipment used in construction or demolition work between the hours of 5:00 p.m. and 8:00 a.m. the following day on weekdays and Saturdays or at any time on Sundays or holidays, such that the sound therefrom creates a noise disturbance across a residential real property boundary, except for emergency work of public service utilities or by special variance issued by the building inspector pursuant to this Code and notification to the police department. Before a waiver is granted, the city council shall be notified that a waiver is being considered. A copy of any special variance issued by the building inspector pursuant to this subsection shall be forwarded to the city council.

not involved

b. *Blasting, rock crushing, jack hammering, hydraulic blasting, pile driving.* The operation of drilling and/or blasting equipment, rock crushing machinery, pile driving, or jack hammers used in construction, reconstruction, repair, or demolition work between the hours of 5:00 p.m. and 8:00 a.m. the following day on weekdays or at any time on Saturdays, Sundays, or holidays, except for emergency work of public service utilities, or by special variance issued by the building inspector pursuant to this Code and notification to the police department. No special variances for any work herein shall be granted by the building inspector for work on Sundays or holidays without prior approval of the city council. Any special variance issued by the building

inspector pursuant to this subsection shall first be approved by the city council.

c. No special variances for any work herein shall be granted by the building inspector for work on Sundays or holidays without prior approval of the city council. All building inspectors, in addition to police officers, shall be enforcing persons for the purposes of this subsection 22-2(5).

(6) *Vehicle or motorboat repairs and testing.* Repairing, rebuilding, modifying or testing any motor vehicle, motorcycle or motorboat in such a manner as to cause a noise disturbance across a residential real property boundary. All building inspectors, in addition to police officers, shall be enforcing persons for the purposes of this subsection.

(7) *Explosives, firearms and similar devices.* The use or firing of explosives, firearms or similar devices which create impulsive sound so as to cause a noise disturbance across a real property boundary or on a public space or right-of-way, without first obtaining a special variance issued pursuant to this Code. Such permit need not be obtained for licensed game-hunting activities on property where such activities are authorized.

(8) *Vibration.* Operating or permitting the operation of any device that creates vibration which is above the vibration perception threshold of an individual at or beyond the property boundary of the source if on private property or at 100 feet from the source if on a public space or public right-of-way. For the purposes of this subsection, the term "vibration perception threshold" means the minimum ground- or structure-borne vibrational motion necessary to cause a normal person to be aware of the vibration by such direct means, such as but not limited to sensation by touch or visual observation of moving objects.

Clerk of the Salem City Council  
93 Washington Street  
Salem, MA 01970

RE: Sammy's Roast Beef  
17 Canal Street, Salem  
Request for extended hours of operation

Dear Honorable Members of the Salem City Council,

My name is Iirian Piku and I reside at 43 Holten Street in Peabody. I am the President and owner of Piku Corporation. I recently purchased the restaurant known as Sammy's Roast Beef from the Zepaj family. Sammy's is a successful and responsible business operating in Salem since 2006. The hours of operation have always been:

Sunday	11:00 AM to 10:00 PM
Monday – Wednesday	11:00 AM to 11:00 PM
Thursday – Saturday	11:00 AM to 2:00 A.M

The extended hours on Thursday to Saturday are the busiest times and critical to the success of the business. I respectfully request the Council's permission to continue operating during these same hours. I am an experienced restaurant operator and look forward to much success in Salem.

Thank you for your time and consideration.

Sincerely,



Ilirian Piku, President  
Piku Corporation

978-818-5358



# CITY OF SALEM, MASSACHUSETTS

PARK, RECREATION & COMMUNITY SERVICE

5 Broad Street, Salem MA 01970

Tel. (978) 744-0180/(978) 744-0924

Fax (978) 744-7225

pobrien@salem.com

Kimberley Driscoll  
MAYOR

Trish O'Brien  
Superintendent

Please Print Clearly or Type

## 2016 Road Race/Walk Application

To the Park, Recreation & Community Services Director:

We, the undersigned, respectfully apply for permission to host a road race/walk in the City of Salem as follows:

Applicant's Name: Chrissy Kenney

Organization Name: HAWC (Healing Abuse Working for Change)

Name of Race/Walk: Walk for HAWC

Contact #: 978-744-2299 x114 E-Mail Address: chrissyk@hawcd.org

Address: 27 Congress St Suite 204

City/State/Zip: Salem MA 01970

Organization Tax Status (please include Tax ID Number): 04-2655367

What Charities Will This Race/Walk Be Benefiting?  
HAWC - a domestic violence agency

Approximately How Much of the Race/Walk Proceeds Will Be Donated to Each Charity(s)  
100%

### Day of Race/Walk Contact Information:

Name: Chrissy Kenney Contact #: 978-604-4720

Date of Race/Walk: 4/30/17 Estimated Number of Runners/Walkers: 700-1,000

Time of Race/Walk: 10:30 Estimated Finish Time of Race/Walk: 3pm

Start Location: Salem Common Finish Location: Salem Common

Distance of Race/Walk: 5K

Has This Event Been Held Before?  Yes  No

### All Races/Walks Are Required to Recycle and Remove Trash.

Please Explain Your Plan (Will You Bring to North Shore Recycled Fiber on 53 Jefferson Ave, Open M-F; Bring to Your Home Curbside, or Other?)

We will arrange for trash & recycling pick-up



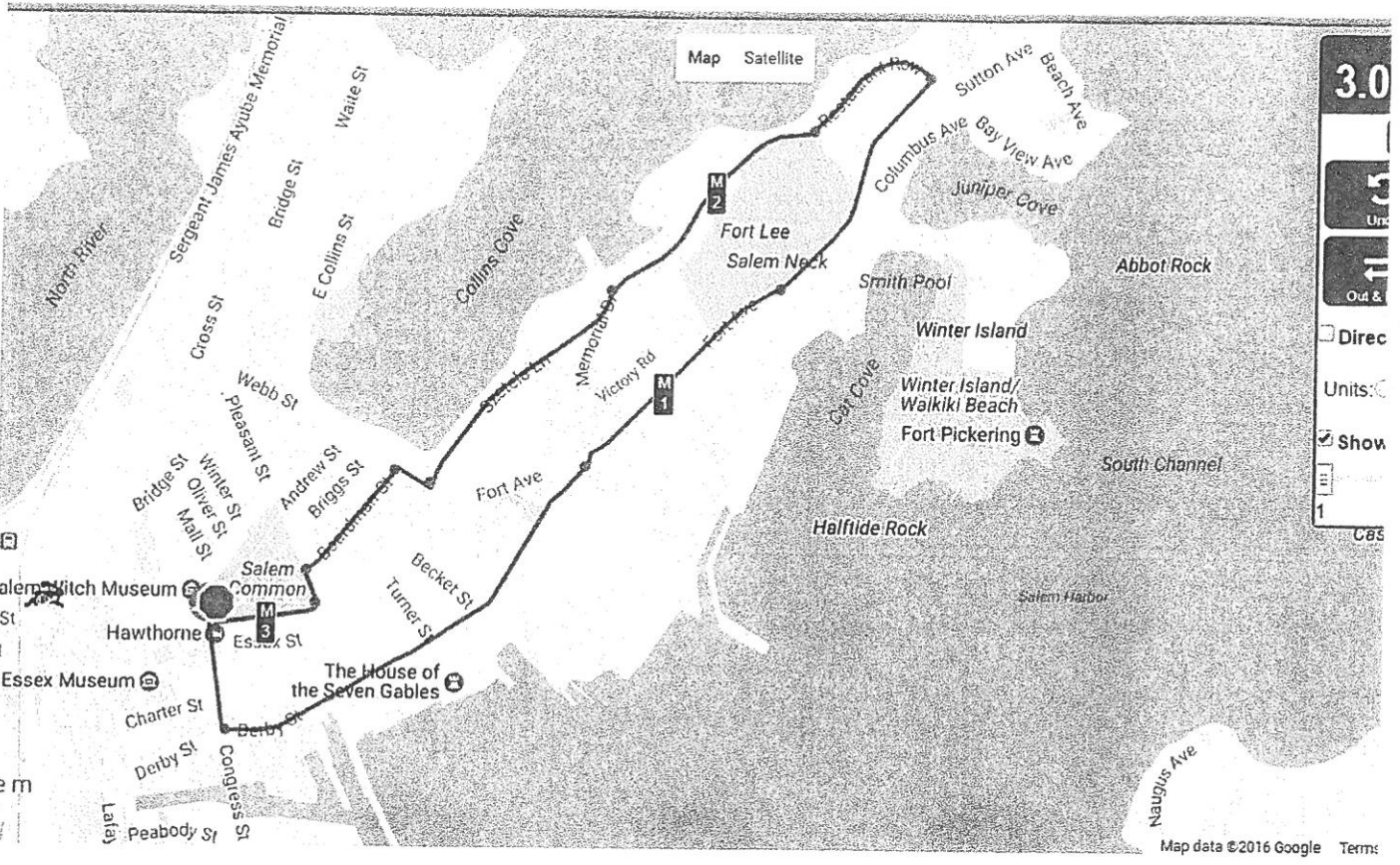

3.0

Map Satellite

Out & In

Units:  Direc

Show

1

CS



# CERTIFICATE OF LIABILITY INSURANCE

DATE (MM/DD/YYYY)

11/01/2016

THIS CERTIFICATE IS ISSUED AS A MATTER OF INFORMATION ONLY AND CONFERS NO RIGHTS UPON THE CERTIFICATE HOLDER. THIS CERTIFICATE DOES NOT AFFIRMATIVELY OR NEGATIVELY AMEND, EXTEND OR ALTER THE COVERAGE AFFORDED BY THE POLICIES BELOW. THIS CERTIFICATE OF INSURANCE DOES NOT CONSTITUTE A CONTRACT BETWEEN THE ISSUING INSURER(S), AUTHORIZED REPRESENTATIVE OR PRODUCER, AND THE CERTIFICATE HOLDER.

**IMPORTANT:** If the certificate holder is an ADDITIONAL INSURED, the policy(ies) must be endorsed. If SUBROGATION IS WAIVED, subject to the terms and conditions of the policy, certain policies may require an endorsement. A statement on this certificate does not confer rights to the certificate holder in lieu of such endorsement(s).

<b>PRODUCER</b> LOPRIORE INS AGCY INC 426 MAIN STREET SUITE 2  STONEHAM MA 02180 77WCF		<b>CONTACT NAME:</b> <b>PHONE (A/C, No, Ext):</b> <b>E-MAIL ADDRESS:</b>		<b>FAX (A/C, No):</b>	
<b>INSURER(S) AFFORDING COVERAGE</b>				<b>NAIC #</b>	
<b>INSURED</b> HEALING ABUSE WORKING FOR CHANGE 27 CONGRESS ST SUITE 204 SALEM MA 01970				<b>INSURER A:</b> HARTFORD UNDERWRITERS INSURANCE COMPANY <b>INSURER B:</b> <b>INSURER C:</b> <b>INSURER D:</b> <b>INSURER E:</b> <b>INSURER F:</b>	

**COVERAGES****CERTIFICATE NUMBER:****REVISION NUMBER:**

THIS IS TO CERTIFY THAT THE POLICIES OF INSURANCE LISTED BELOW HAVE BEEN ISSUED TO THE INSURED NAMED ABOVE FOR THE POLICY PERIOD INDICATED. NOTWITHSTANDING ANY REQUIREMENT, TERM OR CONDITION OF ANY CONTRACT OR OTHER DOCUMENT WITH RESPECT TO WHICH THIS CERTIFICATE MAY BE ISSUED OR MAY PERTAIN, THE INSURANCE AFFORDED BY THE POLICIES DESCRIBED HEREIN IS SUBJECT TO ALL THE TERMS, EXCLUSIONS AND CONDITIONS OF SUCH POLICIES. LIMITS SHOWN MAY HAVE BEEN REDUCED BY PAID CLAIMS.

INSR LTR	TYPE OF INSURANCE	ADDL INSR	SUBR WVD	POLICY NUMBER	POLICY EFF (MM/DD/YYYY)	POLICY EXP (MM/DD/YYYY)	LIMITS	
	<b>GENERAL LIABILITY</b> <input type="checkbox"/> COMMERCIAL GENERAL LIABILITY <input type="checkbox"/> CLAIMS-MADE <input type="checkbox"/> OCCUR  GEN'L AGGREGATE LIMIT APPLIES PER: <input type="checkbox"/> POLICY <input type="checkbox"/> PROJECT <input type="checkbox"/> LOC						EACH OCCURRENCE \$ DAMAGE TO RENTED PREMISES (Ea occurrence) \$ MED EXP (Any one person) \$ PERSONAL & ADV INJURY \$ GENERAL AGGREGATE \$ PRODUCTS - COMP/OP AGG \$	
	<b>AUTOMOBILE LIABILITY</b> <input type="checkbox"/> ANY AUTO <input type="checkbox"/> SCHEDULED AUTOS <input type="checkbox"/> ALL OWNED AUTOS <input type="checkbox"/> NON-OWNED AUTOS <input type="checkbox"/> HIRED AUTOS  <input type="checkbox"/> UMBRELLA LIAB <input type="checkbox"/> OCCUR <input type="checkbox"/> EXCESS LIAB <input type="checkbox"/> CLAIMS-MADE <input type="checkbox"/> DED <input type="checkbox"/> RETENTION \$						COMBINED SINGLE LIMIT (Ea accident) \$ BODILY INJURY (Per person) \$ BODILY INJURY (Per accident) \$ PROPERTY DAMAGE (Per accident) \$ \$ EACH OCCURRENCE \$ AGGREGATE \$ \$	
A	<b>WORKERS COMPENSATION AND EMPLOYERS' LIABILITY</b> ANY PROPRIETOR/PARTNER/EXECUTIVE OFFICER/MEMBER EXCLUDED? (Mandatory in NH) Y/N If yes, describe under DESCRIPTION OF OPERATIONS below			(6S60UB-4414P82-4-16)	10-11-16	10-11-17	<input checked="" type="checkbox"/> WC STATUTORY LIMITS <input type="checkbox"/> OTH-ER	E.L. EACH ACCIDENT \$ 100,000 E.L. DISEASE - EA EMPLOYEE \$ 100,000 E.L. DISEASE - POLICY LIMIT \$ 500,000
DESCRIPTION OF OPERATIONS/LOCATIONS/VEHICLES (Attach ACORD 101, Additional Remarks Schedule, if more space is required)								

**CERTIFICATE HOLDER****CANCELLATION**

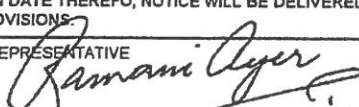
CORCORAN & HAVLIN INS 287 LINDEN ST WELLESLEY MA 02482	SHOULD ANY OF THE ABOVE DESCRIBED POLICIES BE CANCELLED BEFORE THE EXPIRATION DATE THEREFO, NOTICE WILL BE DELIVERED IN ACCORDANCE WITH THE POLICY PROVISIONS. AUTHORIZED REPRESENTATIVE 
--	---

©1988-2010 ACORD CORPORATION. All rights reserved.



# CITY OF SALEM, MASSACHUSETTS

Park, Recreation & Community Services  
5 Broad Street

Salem, Massachusetts 01970

Tel. (978) 744-0180 Or (978) 744-0924

Fax (978) 744-7225

Kpartanen@salem.com

**Kimberley Driscoll**  
Mayor

**Karen Partanen**  
Director

## Please Print Clearly or Type 2015 Road Race/Walk Application

**To the Park, Recreation & Community Services Director:**

We, the undersigned, respectfully apply for permission to host a road race/walk in the City of Salem as follows:

Applicant's Name: Katie Partyka

Organization Name: Salem YMCA

Name of Race/Walk: Witch City Triathlon

Contact #: 781 990 7063 E-Mail Address: partykalk@northshoreymca.org

Address: 1 Sewal St

City/State/Zip: Salem MA 01970

Organization Tax Status (please include Tax ID Number): Non Profit 042-104-913

What Charities Will This Race/Walk Be Benefiting? Salem YMCA

Approximately How Much of the Race/Walk Proceeds Will Be Donated to Each Charity(s)  
100%

### Day of Race/Walk Contact Information:

Name: Katie Partyka Contact #: 781 990 7063

Date of Race/Walk: Aug 12th ~~Aug 5th~~ Estimated Number of Runners/Walkers: 150

Time of Race/Walk: 7am Estimated Finish Time of Race/Walk: 10am

Start Location: Forest River Finish Location: Forest River

Distance of Race/Walk: 1/2 Mi SWIM, 5K Run, 13 Mi Bike

Has This Event Been Held Before?  Yes  No

### All Races/Walks Are Required to Recycle and Remove Trash.

Please Explain Your Plan (Will You Bring to North Shore Recycled Fiber on 53 Jefferson Ave, Open M-F; Bring to Your Home Curbside, or Other?)

We will bring our own bins & remove them ourselves

If You Have Questions about Recycling, Please Contact Julie Rose for More Information 978-619-5679

Will the Organizers Provide Onsite EMT/Ambulance Service (Required):  Yes  No

Please Attach a Map of Route With the Following Items:

1. Race/Walk Course
2. Direction of Runners Through the Race/Walk
3. Starting and Finishing Points
4. Meeting Points For Racers Before and After the Race/Walk
5. Race/Walk in Progress Warning Signs

Does Race/Walk Have Insurance (Required)  Yes  No

Certificate of Insurance Attached?  Yes  No

Name of Insurance Company: \_\_\_\_\_

Please explain the plan for notification to residents of street closures: \_\_\_\_\_  
\_\_\_\_\_  
\_\_\_\_\_

A certificate of insurance for general liability naming the City of Salem as primary additional insured for amount not less than \$1,000,000 combined single limit for injury or death or property damages (including loss of use) in any one occurrence, and \$1,000,000 general aggregate coverage. (The City of Salem reserves the right to increase coverage minimum if event presents extraordinary risk).

**RELEASE & INDEMNITY AGREEMENT APPLICANT'S SIGNATURE** The undersigned Sponsor, by signature below, shall defend, indemnify, and hold the City of Salem, its officers, agents and employees, harmless against all liability, loss, or expenses, including attorney's fees, and against all claims, actions or judgments based upon or arising out of damage or injury (including death) to persons or property caused by any act or omission of an act sustained in any way in connections with the performance of this event or by conditions created thereby, or based upon violation of any statute, ordinance or regulation. This contractual indemnity provision does not abrogate common law or statutory liability and indemnification to the City of Salem, but is in addition to such common law or statutory provisions.

  
Applicant's signature

Date: 2/14/17

\_\_\_\_\_  
Name of applicant

PLEASE SUBMIT PAYMENT OF \$200 WITH THIS PERMIT TO THE CITY OF SALEM PARK, & RECREATION DEPARTMENT **NO LATER THAN 45 DAYS PRIOR TO THE EVENT.**

A copy of this permit will be sent to the applicant upon approval

Please call Park, Recreation & Community Services if you have any questions. 978-744-0180

**CITY USE ONLY**

Payment Received: \_\_\_\_\_ Date Permit Issued: \_\_\_\_\_ Date Permit Mailed to Applicant: \_\_\_\_\_

Approved By:

  
\_\_\_\_\_  
Director (Or Designee) of Salem Park, Recreation & Community Services

  
\_\_\_\_\_  
Salem Police Department

Effective date of form: 2/8/12

Revised date of form: 9/25/14



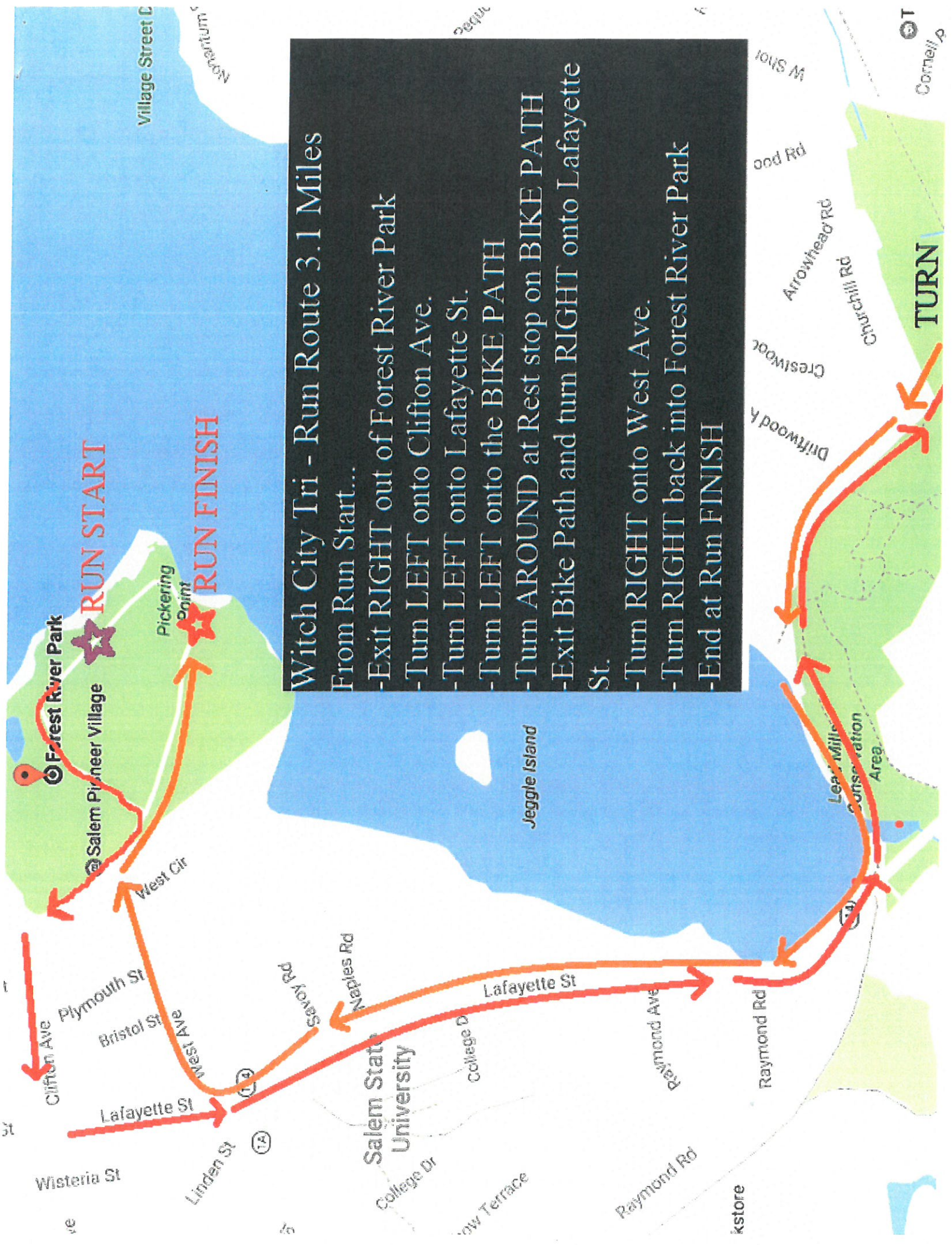

**Witch City Tri - Run Route 3.1 Miles**

From Run Start...

- Exit **RIGHT** out of Forest River Park
- Turn **LEFT** onto Clifton Ave.
- Turn **LEFT** onto Lafayette St.
- Turn **LEFT** onto the BIKE PATH
- Turn **AROUND** at Rest stop on BIKE PATH
- Exit Bike Path and turn **RIGHT** onto Lafayette St.
- Turn **RIGHT** onto West Ave.
- Turn **RIGHT** back into Forest River Park
- End at Run **FINISH**

**TURN**



## Witch City Triathlon 2017 Swim Course

Starting at the forest river park pickering point beach next to the bath-house and pool, athletes will complete a half mile counter clockwise swim exiting the water back onto the beach.

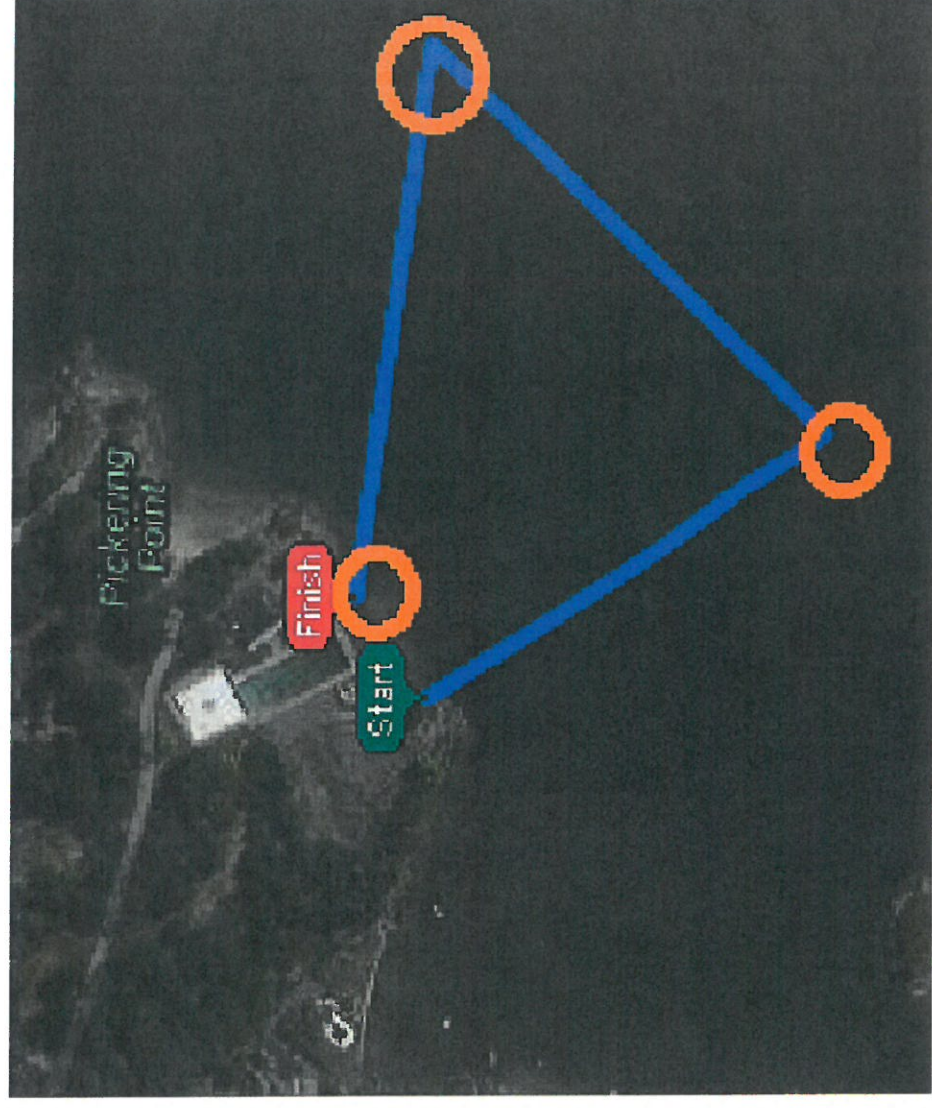



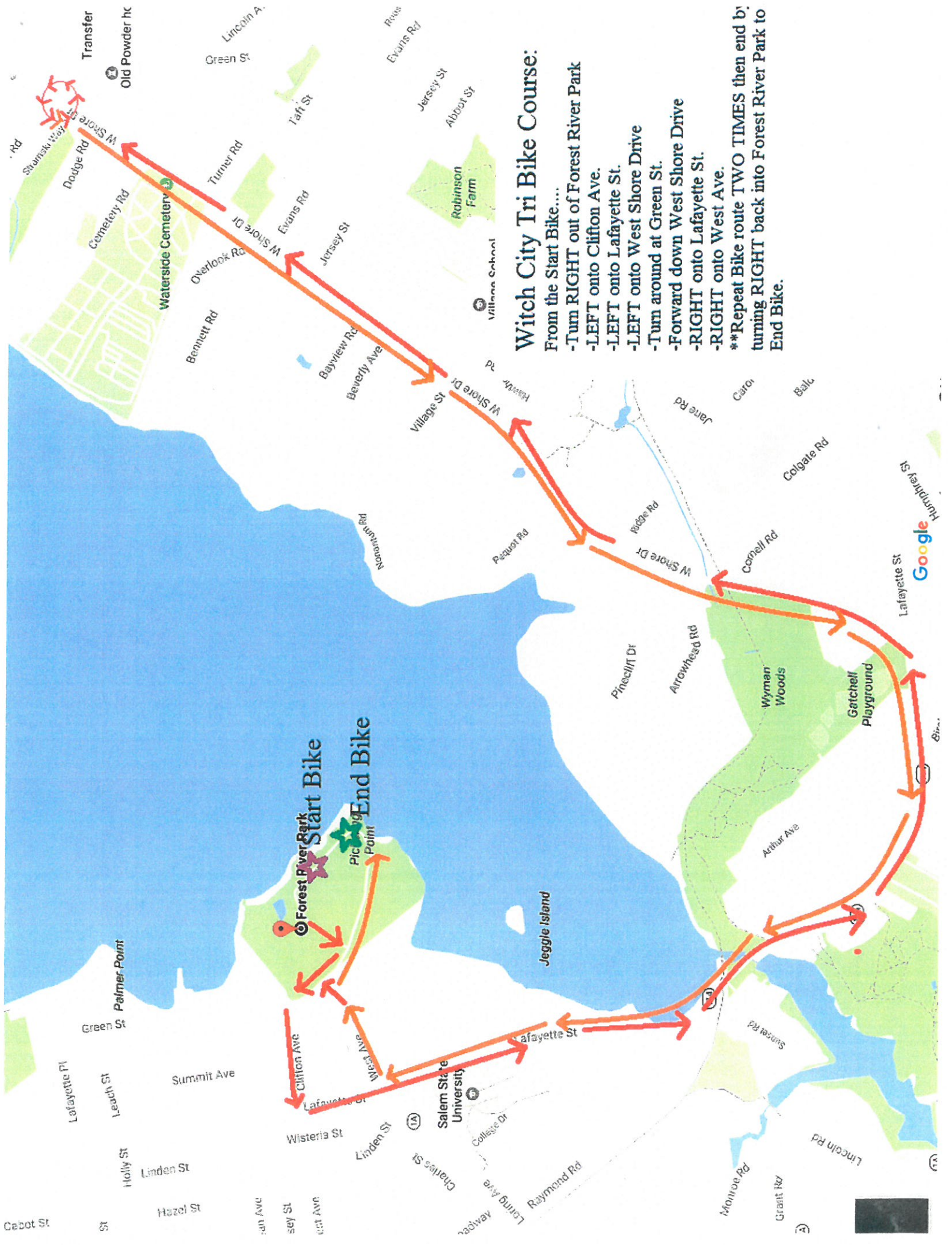

### Witch City Tri Bike Course:

- From the Start Bike....
- Turn **RIGHT** out of Forest River Park
  - LEFT** onto Clifton Ave.
  - LEFT** onto Lafayette St.
  - LEFT** onto West Shore Drive
  - Turn around at Green St.
  - Forward down West Shore Drive
  - RIGHT** onto Lafayette St.
  - RIGHT** onto West Ave.
  - \*\*Repeat Bike route TWO TIMES then end by turning RIGHT back into Forest River Park to End Bike.**

**Forest River Park**  
**Start Bike**  
**End Bike**

**MIA PROPERTY AND CASUALTY GROUP, INC.**  
**CERTIFICATE OF INSURANCE**

ISSUE DATE: 10/26/2016

**INSURED:**  
 Salem, City of  
 93 Washington Street  
 Salem, MA 01970  
 Attn: Sarah Stanton

THIS CERTIFICATE IS ISSUED AS A MATTER OF INFORMATION ONLY AND CONFERS NO RIGHTS UPON THE CERTIFICATE HOLDER. THIS CERTIFICATE DOES NOT AMEND, EXTEND OR ALTER THE COVERAGE AFFORDED BY THE CONTRACTS BELOW.

THIS IS TO CERTIFY THAT CONTRACTS OF INSURANCE LISTED BELOW HAVE BEEN ISSUED TO THE INSURED NAMED ABOVE FOR THE CONTRACT PERIOD INDICATED. NOTWITHSTANDING ANY REQUIREMENT, TERM OR CONDITION OF ANY CONTRACT OR OTHER DOCUMENT WITH RESPECT TO WHICH THIS CERTIFICATE MAY BE ISSUED OR MAY PERTAIN, THE INSURANCE AFFORDED BY THE CONTRACTS DESCRIBED HEREIN IS SUBJECT TO ALL THE TERMS, EXCLUSIONS, AND CONDITIONS OF SUCH CONTRACTS.

	POLICY NUMBER	CONTRACT EFFECTIVE DATE	CONTRACT EXPIRATION DATE	LIABILITY LIMITS IN THOUSANDS		
<b>GENERAL LIABILITY</b> <input checked="" type="checkbox"/> Comprehensive Form <input type="checkbox"/> Premises, Operations <input type="checkbox"/> Underground Explosion Collapse Hazard <input type="checkbox"/> Products/Completed Operations <input type="checkbox"/> Contractual <input type="checkbox"/> Independent Contractors <input type="checkbox"/> Broad Form Property Damage <input type="checkbox"/> Personal Injury	SAL00111-03-16	07/01/2016	07/01/2017	BODILY INJURY		
				PROPERTY DAMAGE		
				BI & PD COMBINED	\$1,000	\$3,000
				PERSONAL INJURY		\$1,000
<b>AUTO LIABILITY</b> <input type="checkbox"/> Any Auto <input type="checkbox"/> All Owned Autos (Priv.Pass) <input type="checkbox"/> All Owned Autos (Other) <input type="checkbox"/> Hired Autos <input type="checkbox"/> Non-Owned Autos <input type="checkbox"/> Garage Liability				BODILY INJURY		PER PERSON
				BODILY INJURY		PER ACCIDENT
				PROPERTY DAMAGE		
				BI & PD COMBINED		
OTHER						

**DESCRIPTION OF OPERATIONS / LOCATIONS / VEHICLES / SPECIAL ITEMS:**

EVIDENCE OF INSURANCE WITH RESPECTS TO USE OF THE FACILITIES BY THE SALEM PUBLIC SCHOOLS THROUGHOUT THE YEAR.

**CERTIFICATE HOLDER:**

SALEM STATE UNIVERSITY  
 O'KEEFE CENTER POOL AND RINK  
 352 LAFAYETTE STREET  
 SALEM, MA 01970

**CANCELLATION:**

SHOULD ANY OF THE ABOVE DESCRIBED CONTRACTS BE CANCELLED BEFORE THE EXPIRATION DATE THEREOF, THE ISSUING COMPANY WILL ENDEAVOR TO MAIL 30 DAYS WRITTEN NOTICE TO THE CERTIFICATE HOLDER NAMED TO THE LEFT, BUT FAILURE TO MAIL SUCH NOTICE SHALL IMPOSE NO OBLIGATION OR LIABILITY OF ANY KIND UPON THE COMPANY, ITS AGENTS OR REPRESENTATIVES.

AUTHORIZED REPRESENTATIVE:



# City of Salem

---

*In the year two thousand and Seventeen*

**An Ordinance** to amend an Ordinance relative to Traffic

*Be it ordained by the City Council of the City of Salem, as follows:*

**Section 1.** Chapter 42, Section 49 - "Obedience to Isolated Stop Sign" is hereby amended by adding the following:

Columbus Square, southerly bound traffic on Columbus Square stop at Winter Island Road. "Stop Sign"

**Section 2.** This Ordinance shall take effect as provided by City Charter.

In City Council February 16, 2017  
Adopted for first passage

ATTEST:

CHERYL A. LAPOINTE  
CITY CLERK

# City of Salem

---

*In the year two thousand and Seventeen*

**An Ordinance** to amend an Ordinance relative to Traffic

*Be it ordained by the City Council of the City of Salem, as follows:*

**Section 1.** Chapter 42, Section 49 - "Obedience to Isolated Stop Sign" is hereby amended by adding the following:

Holyoke Square, southerly bound traffic on Holyoke Square stop at Gedney Street. "Stop Sign"

**Section 2.** This Ordinance shall take effect as provided by City Charter.

In City Council February 16, 2017  
Adopted for first passage

ATTEST:

CHERYL A. LAPOINTE  
CITY CLERK

# City of Salem

---

*In the year two thousand and Seventeen*

**An Ordinance** to amend an Ordinance relative to Traffic

*Be it ordained by the City Council of the City of Salem, as follows:*

**Section 1.** Chapter 42, Section 55B. - Prohibited from parking—Residential districts or in front of residential housing or apartments or entrance corridor overlay districts—Commercial vehicles.

Commercial Vehicles Prohibited from parking in residential districts: Exception: penalty.

(f) Commercial vehicles parked directly in front of a legal "nonconforming" business, located in any "R" (residential) district within the City, shall be exempted from the provisions of this Ordinance if the commercial vehicle is registered to that particular address of the legal "nonconforming" business.

**Section 2.** This Ordinance shall take effect as provided by City Charter.

In City Council February 16, 2017

Adopted for first passage and referred to the Committee on Ordinances, Licenses and Legal Affairs

ATTEST:

CHERYL A. LAPOINTE  
CITY CLERK

# City of Salem

---

*In the year two thousand and Seventeen*

**An Ordinance** to amend an Ordinance relative to Traffic

*Be it ordained by the City Council of the City of Salem, as follows:*

**Section 1.** Chapter 42, Section 50B. – “Handicap Parking – Limited Time’

Appleton Street in front of #61, for a distance of twenty (20) feet. “Handicap Parking Tow Zone”.

**Section 2.** This Ordinance shall take effect as provided by City Charter.

In City Council February 23, 2017  
Adopted for first passage

ATTEST:

CHERYL A. LAPOINTE  
CITY CLERK