



CITY OF SALEM, MASSACHUSETTS

Kimberley Driscoll
Mayor

Office of the Mayor

March 24, 2022

Honorable Salem City Council
Salem City Hall
Salem, Massachusetts 01970

Ladies and Gentlemen of the City Council:

I am pleased to appoint Thomas Philbin of 6 Planters Street to the Salem Conservation Commission for a three-year term to expire March 24, 2025. Mr. Philbin will take the seat previously held by Mr. Scott Sheehan who has stepped down from the Commission. Please join me in thanking Mr. Philbin for his dedicated service to our community and the Conservation Commission.

Mr. Philbin is currently the Director of Waterfront and Resiliency for the City of Everett where he staffs that city's Conservation Commission and oversees the community's work relative to waterfront planning, Chapter 91, Article 87, brownfields redevelopment, and the Municipal Harbor Plan. Previous to his current position Mr. Philbin was the Chief of Communications for the City of Everett and a senior legislative analyst at the Massachusetts Municipal Association. Locally he has worked as the Chief of Staff for the City of Salem under the previous administration and as the Executive Director of the Greater Salem Boys and Girls Club.

I strongly recommend confirmation of Mr. Philbin's appointment to the Conservation Commission. We are fortunate that he is willing to serve our community and lend his expertise and insights to the Commission and its ongoing work.

Sincerely,

Kimberley Driscoll
Mayor
City of Salem



CITY OF SALEM, MASSACHUSETTS

Kimberley Driscoll
Mayor

Office of the Mayor

March 24, 2022

Honorable Salem City Council
Salem City Hall
Salem, Massachusetts 01970

Ladies and Gentlemen of the City Council:

I am pleased to appoint Elvis Gustavo Alvarez of 7 Champlain Road to the Sustainability, Energy, and Resiliency Committee for a three-year term to expire March 24, 2025. Mr. Alvarez will fill the seat previously occupied by Mr. Jeff Cohen, who stepped down from the committee when he was elected to the City Council.

Mr. Alvarez currently works as a paraprofessional at the Collins Middle School here in Salem and as a program manager for Turning Point, a non-profit residential facility that serves individuals with intellectual and developmental disabilities. He is a member of the Latino Leadership Coalition and currently serves as that organization's vice president. Mr. Alvarez has volunteered locally with the Wicked Running Club and the Boys and Girls Club of Greater Salem. He is pursuing Bachelor's degrees in psychology and political science at Salem State University. In addition to bringing greater diversity of race and age to SERC, Mr. Alvarez has a deep commitment to our community and passion for problem-solving.

I strongly recommend confirmation of Mr. Alvarez's appointment to the Committee. We are fortunate that he is willing to serve our community in this capacity and lend his dedication to the Committee and its work.

Sincerely,

A handwritten signature in black ink that reads "Kim Driscoll".

Kimberley Driscoll
Mayor
City of Salem



CITY OF SALEM, MASSACHUSETTS

Kimberley Driscoll
Mayor

Office of the Mayor

March 24, 2022

Honorable Salem City Council
Salem City Hall
Salem, Massachusetts 01970

Ladies and Gentlemen of the City Council:

I am pleased to appoint Jeremy Baker of 90 Washington Square to the Beautification Committee for a three-year term to expire March 24, 2025. Mr. Baker will be filling a seat that is currently vacant on the committee.

Mr. Baker currently works professionally as the Chief Financial Officer for First Realty Management in Boston and has held a number of financial and management leadership positions in a variety of companies since 1997. He earned a M.B.A. from Griffith Business School in Australia and has expansive experience in project management. As a relatively new resident of Salem and the Common neighborhood, Mr. Baker is deeply interested in volunteering his time and energy to help maintain and improve the quality of life in our community. He has attended a number of Beautification Committee meetings already and is eager to help support the group in their ongoing efforts to make Salem an even more attractive and pleasant place for everyone.

I strongly recommend confirmation of Mr. Baker's appointment to the Committee. We are fortunate that he is willing to serve our community in this capacity and lend his passion and dedication to the Committee and its work.

Sincerely,

Kimberley Driscoll
Mayor
City of Salem



CITY OF SALEM, MASSACHUSETTS

Kimberley Driscoll
Mayor

Office of the Mayor

April 14, 2022

Honorable Salem City Council
Salem City Hall
Salem, Massachusetts 01970

Ladies and Gentlemen of the City Council:

I am pleased to appoint Veronica Faustino of 64 Rainbow Terrace to the Salem Housing Authority for a five year term to expire April 14, 2027. Ms. Faustino comes with the recommendation of the Salem Housing Authority Tenants Association will fill the seat intended for a tenant representative.

Ms. Faustino is currently the direct service coordinator for the Salem Public Schools' Hawthorne Program, which provides transitional supports for students who have been hospitalized or out of school for medical reasons, as they reintegrate with the district and their classrooms. Prior to that she was an EMT with People Science Inc. Ms. Faustino received her Bachelor's degree from UMass-Boston and completed graduate coursework in mental health counseling and behavioral medicine at Boston University. She serves on the Board of Directors of Family Promise North Shore Boston and chairs the Board's Dismantling Anti-Blackness Committee.

I strongly recommend confirmation of Ms. Faustino's appointment. We are fortunate that she is willing to serve our community in this important role and lend her perspective and dedication to the Authority and its work.

Sincerely,

Kimberley Driscoll
Mayor
City of Salem



CITY OF SALEM, MASSACHUSETTS

Kimberley Driscoll
Mayor

Office of the Mayor

April 14, 2022

Honorable Salem City Council
Salem City Hall
Salem, Massachusetts 01970

Ladies and Gentlemen of the City Council:

I am pleased to appoint Mr. Johnel Roberts of 135 Lafayette Street #212 to the Parks and Recreation Commission for a five-year term to expire October 18, 2023. Mr. Roberts will fill the seat previously occupied by Mr. Emiluis Perez, who has stepped down from the Commission as he is moving. Please join me thanking Mr. Perez for his service to the Commission and to our community.

Mr. Roberts currently runs the Salem-based Young Soldiers Success Group, a nonprofit organization he founded in 2019 to provide mentoring and athletics programs to youth in the community. A first-generation immigrant from the Dominican Republic, Mr. Roberts has been a deeply engaged and positive contributor to the fabric of our city. He has worked as a staffer at the Boys and Girls Club of Greater Salem's summer camp program, coached 6th and 7th graders on the Salem travel basketball team in the Cape Ann League, and, while a student at Stonehill College pursuing his degree in business administration, volunteered as a coach for the Sharon Shooting Stars basketball league for youth with autism and was a Reading Buddy in the Easton elementary schools.

I strongly recommend confirmation of Mr. Roberts to the Parks and Recreation Commission. We are fortunate that he is willing to serve our community in this capacity and lend his dedication and passion to the Commission and its work.

Sincerely,

Kimberley Driscoll
Mayor
City of Salem



CITY OF SALEM, MASSACHUSETTS

Kimberley Driscoll
Mayor

Office of the Mayor

April 14, 2022

Honorable Salem City Council
Salem City Hall
Salem, Massachusetts 01970

Ladies and Gentlemen of the City Council:

I am pleased to appoint Bruce Cohen of 72 Flint Street to the Salem Recycling Committee. This letter is being provided to you for informational purposes only, as City Council confirmation is not required for this committee.

Mr. Cohen is a committed sustainability advocate and an experienced project manager. He has worked for Fireflower Alternative Energy and Clean Water Action in Boston. Mr. Cohen holds a Bachelor's degree in history from the University of Wisconsin and a Graduate Certificate in Sustainability and Environmental Management from the Harvard Extension School. Locally he volunteers with Sustainable Marblehead on the organization's Clean Energy and Public Policy Committee and with the Salem Pantry.

Please join me in welcoming Mr. Cohen to SalemRecycles. We are fortunate that he is willing to serve our community in this important role and lend his expertise and dedication to the group and its work.

Sincerely,

Kimberley Driscoll
Mayor
City of Salem



CITY OF SALEM, MASSACHUSETTS

Kimberley Driscoll
Mayor

Office of the Mayor

April 14, 2022

Honorable Salem City Council
Salem City Hall
Salem, Massachusetts 01970

Ladies and Gentlemen of the City Council:

I am pleased to appoint Ms. Robin Panzer of 12 Woodbury Court to the Salem Cultural Council for a three-year term to expire April 14, 2025. This letter is being submitted to you for informational purposes as no City Council confirmation is required for this appointment.

Ms. Panzer is a communications professional who has worked as a directed study supervisor and faculty advisor at Salem State University and Endicott College. At SSU she has helped manage and grow the university radio station, WMWM. Ms. Panzer earned her Bachelor's degree from Boston University's School of Public Communications and her Master's degree in communications studies from Emerson College. She has volunteered locally providing community outreach and publicity support for the Salem High School Music Boosters and is currently serving on the district's Stakeholder Advisory Team for the ongoing facilities master planning process.

I hope you will join me in welcoming Ms. Panzer to the Cultural Council. We are fortunate that she is willing to serve our community in this capacity and lend her dedication and insights to the Council and its work.

Sincerely,

Kimberley Driscoll
Mayor
City of Salem



CITY OF SALEM, MASSACHUSETTS

Kimberley Driscoll
Mayor

Office of the Mayor

April 14, 2022

Honorable Salem City Council
Salem City Hall
Salem, Massachusetts 01970

Ladies and Gentlemen of the City Council:

I reappoint, subject to City Council confirmation, Geraldine Yuhas of 28 C Federal Street to the Board of Health for a term of 3 years to expire April 14, 2025.

I recommend confirmation of this reappointment and ask that you join me in thanking Ms. Yuhas for her continued dedicated service and commitment to our community.

Sincerely,

Kimberley Driscoll
Mayor
City of Salem



CITY OF SALEM, MASSACHUSETTS

Kimberley Driscoll
Mayor

Office of the Mayor

April 14, 2022

Honorable Salem City Council
Salem City Hall
Salem, Massachusetts 01970

Ladies and Gentlemen of the City Council:

I reappoint, subject to City Council confirmation, Amy Everitt of 14 Columbus Avenue to the Parks & Recreation Commission for a term of 5 years to expire April 25, 2027.

I recommend confirmation of this reappointment and ask that you join me in thanking Ms. Everitt for her continued dedicated service and commitment to our community.

Sincerely,

Kimberley Driscoll
Mayor
City of Salem



CITY OF SALEM, MASSACHUSETTS

Kimberley Driscoll
Mayor

Office of the Mayor

April 14, 2022

Honorable Salem City Council
Salem City Hall
Salem, Massachusetts 01970

Ladies and Gentlemen of the City Council:

I reappoint, subject to City Council confirmation, Sam Lim of Atlantic Hall, SSU to the Scholarship and Education Committee for a term of 3 years to expire April 14, 2025.

I recommend confirmation of this reappointment and ask that you join me in thanking Mr. Lim for their continued dedicated service and commitment to our community.

Sincerely,

Kimberley Driscoll
Mayor
City of Salem



CITY OF SALEM

In City Council,

Ordered:

April 14, 2022

That the sum of Fourteen Thousand Five Hundred Dollars (\$14,500.00) is hereby transferred from the Inspectional Services Department's "FT Salaries" account (12411-5111) to the Inspectional Services Department's "Contracted Services" account as provided below to cover costs associated with contracted plumbing and gas inspectional services due to department vacancies in accordance with the recommendation of Her Honor the Mayor.

| Description | Fund | Amount |
|---------------------|------------|---------------------|
| Contracted Services | 12412-5320 | \$ 14,500.00 |
| | | \$ 14,500.00 |



CITY OF SALEM, MASSACHUSETTS

Kimberley Driscoll
Mayor

April 14, 2022

To the City Council
City Hall
Salem, Massachusetts

Ladies and Gentlemen of the Council:

Enclosed herewith is a request to transfer Fourteen Thousand Five Hundred Dollars (\$14,500.00) from the existing Inspectional Services Department's "FT Salaries" account 12411-5111 to the Inspectional Services Department's "Contracted Services" account 12412-5320.

This transfer is to cover the costs associated with contracted plumbing and gas inspectional services due to department vacancies.

I recommend passage of the accompanying Order.

Very truly yours,

A handwritten signature in black ink that reads "Kimberley Driscoll".

Kimberley Driscoll
Mayor



KIMBERLEY DRISCOLL
MAYOR

CITY OF SALEM, MASSACHUSETTS
BUILDING DEPARTMENT
98 WASHINGTON STREET, 2ND FLOOR
TEL. (978) 745-9595

THOMAS ST. PIERRE
DIRECTOR OF PUBLIC PROPERTY/BUILDING COMMISSIONER

March 29, 2022

Mayor Kimberley Driscoll
City of Salem
93 Washington Street
Salem, MA 01970

Dear Mayor Driscoll,

I am requesting funds from the Payroll account (12411-5111) be transferred to fund the Contract Services account (12412-5320). The additional funds are needed to cover interim gas and plumbing inspection services for the balance of this fiscal year.

Attached is the completed Budget Transfer Request Form for your review and approval.

Thank you for your attention in this matter.

Sincerely,

A handwritten signature in cursive script, appearing to read "Thomas St. Pierre".

Thomas St. Pierre
Director of Inspectional Services

Enclosure

CITY OF SALEM - Finance Department

Free Cash, W & S R/E, R/Res & Budget Transfer Request Form

From: Inspectional Services  March 29, 2022
Department Department Head Authorizing Signature Date

Budget or R/Res Budget Amt: \$ 20,150.00
Transfers To: 12412-5320 Desc: Contracted Services Balance: \$ 758.00
(Org/Object) Budget Amt: \$613,049.00
 From: 12411-5111 Desc: Personnel Balance: \$196,933.21
(*Note - Please include letter to Mayor for Transfers from different Personnel & Non-personnel lines)
 Current Balance in Receipts Reserved Fund Above (if applicable) - \$ _____ Date: _____

Free Cash or To: _____ Desc: _____ Budget Amt: \$ _____
Balance: \$ _____
Retained Earnings (W/S) (Org/Object)
Raise & Appropriate
 Please circle one

Amount Requested: \$ 14,500.00
Reason (Be Specific) Requesting a transfer of \$14,500 from Personnel account to Contracted Services to cover ongoing plumbing and gas inspectional services until new Plumbing/Gas Inspector is hired.

For Finance Department and Mayor's Use Only:

Budget Transfer Mayor Approval City Council Approval
 _____ Free Cash Appropriation - City Council Approval - Gen Fund \$ _____ Free Cash Balance
 _____ R/E Appropriation - Water \$ _____ _____ R/E Appropriation Sewer \$ _____ R/E Balance
 _____ Receipts Reserve - City Council Approval \$ _____ R/Res Fund Balance
 _____ Raise & Appropriate _____ Other _____
Recommendation: Approved Denied 
Finance Director

Completed: Date: _____ By: _____ CO # _____ JE#: _____ Transfer #: _____



CITY OF SALEM

In City Council,

Ordered:

April 14, 2022

That the sum of Eleven Thousand Dollars (\$11,000.00) is hereby transferred and appropriated from the Receipts Reserved funds listed below to the Department of Public Services Burial Account (14112-5383) in accordance with the recommendation of Her Honor the Mayor.

| From | | To | | Amount |
|--------------|----------------------|------------|------------|---------------------|
| 2430-4800 | R/Res Sale of Lots | 14112-5383 | DPS Burial | \$ 8,000.00 |
| 2431-4800 | R/Res Sale of Vaults | 14112-5383 | DPS Burial | 3,000.00 |
| Total | | | | \$ 11,000.00 |



CITY OF SALEM, MASSACHUSETTS

Kimberley Driscoll
Mayor

April 14, 2022

To the City Council
City Hall
Salem, Massachusetts

Ladies and Gentlemen of the Council:

Enclosed herewith is a request for an appropriation of Eleven Thousand Dollars (\$11,000.00) from the "Receipts Reserved" funds listed below to the Department of Public Services Burial Account (14112-5383).

| FROM | | | TO | AMOUNT |
|-------------|----------------------|------------|---------------|--------------------|
| 2430-4800 | R/Res Sale of Lots | 14112-5383 | DPS Burial | \$ 8,000.00 |
| 2431-4800 | R/Res Sale of Vaults | 14112-5383 | DPS Burial | \$ 3,000.00 |
| | | | Total: | <u>\$11,000.00</u> |

This appropriation is necessary to purchase burial boxes for burial services for the cemetery.

I recommend passage of the accompanying Order.

Very truly yours,

A handwritten signature in black ink that reads "Kimberley Driscoll".

Kimberley Driscoll
Mayor

CITY OF SALEM - Finance Department

Free Cash, W & S R/E, R/Res & Budget Transfer Request Form

From: DPS Department *[Signature]* Department Head Authorizing Signature 2/2/22 Date

Budget or R/Res Transfers To: 14112-5383 (Org/Object) Desc: Burial Services Budget Amt: 1606.94 Balance: 1606.94

From: 24301-4800 Desc: Sale of Lots Budget Amt: 12,893 Balance: 12,893
 (*Note - Please include letter to Mayor for Transfers from different Personnel & Non-personnel lines)

Current Balance in Receipts Reserved Fund Above (if applicable) - \$ _____ Date: _____

Free Cash or Retained Earnings (W/S) To: _____ Desc: _____ Budget Amt: _____ Balance: _____
 (Org/Object)
Raise & Appropriate
 Please circle one

Amount Requested: \$ 8,000
 Reason (Be Specific) Transfer needed for Burial Services
at Cemetery

For Finance Department and Mayor's Use Only:

Budget Transfer Mayor Approval City Council Approval
 Free Cash Appropriation - City Council Approval - Gen Fund \$ _____ Free Cash Balance
 R/E Appropriation - Water \$ _____ R/E Balance R/E Appropriation Sewer \$ _____ R/E Balance
 Receipts Reserve - City Council Approval \$ _____ R/Res Fund Balance
 Raise & Appropriate Other _____

Recommendation: Approved Denied _____
Finance Director

Completed: Date: _____ By: _____ CO # _____ JE#: _____ Transfer #: _____

CITY OF SALEM - Finance Department

Free Cash, W & S R/E, R/Res & Budget Transfer Request Form

From: DPS Department Dasha Department Head Authorizing Signature 2/2/22 Date

Budget or R/Res Transfers To: 14112-5383 (Org/Object) Desc: Burial Services Budget Amt: _____ Balance: 1606.94

From: 24311-4500 Desc: Sale of vaults Budget Amt: _____ Balance: 5876.39
 (*Note - Please include letter to Mayor for Transfers from different Personnel & Non-personnel lines)

Current Balance in Receipts Reserved Fund Above (if applicable) - \$ _____ Date: _____

Free Cash or Retained Earnings (W/S) To: _____ Desc: _____ Budget Amt: _____ Balance: _____
 (Org/Object)
Raise & Appropriate
 Please circle one

Amount Requested: \$ 3,000
 Reason (Be Specific) Transfer needed for Burial Services @ Cemetery

For Finance Department and Mayor's Use Only:

Budget Transfer Mayor Approval City Council Approval
 Free Cash Appropriation - City Council Approval - Gen Fund \$ _____ Free Cash Balance
 R/E Appropriation - Water \$ _____ R/E Balance R/E Appropriation Sewer \$ _____ R/E Balance
 Receipts Reserve - City Council Approval \$ _____ R/Res Fund Balance
 Raise & Appropriate Other _____

Recommendation: Approved Denied _____ Finance Director

Completed: Date: _____ By: _____ CO # _____ JE#: _____ Transfer #: _____



CITY OF SALEM

In City Council,

Ordered:

April 14, 2022

That the sum of Eight Thousand Nine Hundred Ninety-Seven Dollars and Forty-Two Cents (\$8,997.42) is hereby transferred from the Purchasing Department's "FT Salaries" account (11381-5111) to the Purchasing Department's "Telephone-Wireless" account as provided below to cover payment associated with a prior year bill for T-Mobile services in accordance with the recommendation of Her Honor the Mayor.

| Description | Fund | Amount |
|--------------------|------------|--------------------|
| Telephone-Wireless | 11392-5341 | \$ 8,997.42 |
| | | \$ 8,997.42 |



CITY OF SALEM, MASSACHUSETTS
Kimberley Driscoll
Mayor

April 14, 2022

To the City Council
City Hall
Salem, Massachusetts

Ladies and Gentlemen of the Council:

Enclosed herewith is a request to transfer Eight Thousand Nine Hundred Ninety-Seven dollars and Forty-Two cents (\$8,997.42) from the existing Purchasing Department's "FT Salaries" account 11381-5111 to the Purchasing Department's "Telephone-Wireless" account.

| Description | Fund | Amount |
|--------------------|------------|------------|
| Telephone-Wireless | 11392-5341 | \$8,997.42 |

This transfer is necessary to cover the costs associated with a prior year bill for T-Mobile services.

I recommend passage of the accompanying Order.

Very truly yours,

Handwritten signature of Kimberley Driscoll in black ink.

Kimberley Driscoll
Mayor

CITY OF SALEM - Finance Department
Free Cash, W & S R/E, R/Res & Budget Transfer Request Form

From: Purchasing
 Department

 Department Head Authorizing Signature

03/29/2022
 Date

Budget or R/Res

Budget Amt: \$47,500.00

Transfers To : 11392-5341
 (Org/Object)

Desc: TELEPHONE-Wireless Balance: \$2,630.96

Budget Amt: \$151,445.00

From : 11381-5111 Desc: SALARIES-FULL TIME Balance: \$49,276.12

(*Note - Please include letter to Mayor for Transfers from different Personnel & Non-personnel lines)

Current Balance in Receipts Reserved Fund Above (if applicable) - \$ _____ Date: _____

Free Cash or To : _____ Desc: _____
Retained Earnings (W/S) (Org/Object)

Budget Amt: _____

Balance: _____

Raise & Appropriate
 Please circle one

Amount Requested: ~~\$8,997.42~~ \$8,997.42

Reason (Be Specific) In March 2020, the City switched its wireless service to T-Mobile. As part of the incentive to switch, the City was due certain rebates that were not initially reflected on the bill. While those rebates were eventually applied, it was not clear how much of the outstanding balance was actually owed, and due to the change in personnel in the Purchasing office in 2021, these bills were never paid.

For Finance Department and Mayor's Use Only:

Budget Transfer Mayor Approval City Council Approval

_____ Free Cash Appropriation - City Council Approval - Gen Fund \$ _____
 Free Cash Balance

_____ R/E Appropriation -Water \$ _____ R/E Balance _____ R/E Appropriation Sewer \$ _____
 R/E Balance R/E Balance

_____ Receipts Reserve - City Council Approval \$ _____
 R/Res Fund Balance

_____ Raise & Appropriate _____ Other _____

Recommendation: Approved _____ Denied

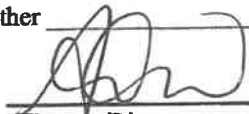
 Finance Director

Completed: Date: _____ By: _____ CO # _____ JE#: _____ Transfer #: _____



CITY OF SALEM

In City Council,

Ordered:

April 14, 2022

Per MGL Chapter 44 Section 64 which allows for a municipality to pay for prior fiscal year invoices using current fiscal year appropriations by two-thirds vote of the City Council we request the sum of Four Thousand Seven Hundred Fifteen Dollars and Eighty-Five Cents (\$4,715.85) of outstanding Fiscal Year 2021 invoices is hereby allowed to be paid from the Fiscal Year 2022 Purchasing Department budget as listed below in accordance with the recommendation of Her Honor the Mayor.

| Department | Vendor | Amount |
|--------------|----------|--------------------|
| Purchasing | T-Mobile | \$ 4,715.85 |
| Total | | \$ 4,715.85 |



CITY OF SALEM, MASSACHUSETTS

**Kimberley Driscoll
Mayor**

April 14, 2022

To the City Council
City Hall
Salem, Massachusetts

Ladies and Gentlemen of the Council:

Pursuant to M.G. L. Chapter 44, section 64, enclosed herewith is a request to authorize the payment of the below described Fiscal Year 2021 invoice from the Fiscal Year 2022 Purchasing Department budget.

This invoice was not received by June 30, 2021, the end of the fiscal year.

| <u>Department</u> | <u>Vendor</u> | <u>Amount</u> |
|-------------------|---------------|---------------|
| Purchasing | T-Mobile | \$4,715.85 |

M.G.L. Chapter 44, section 64 allows a municipality to pay for prior fiscal year invoices using current fiscal year appropriations by a two-thirds vote of the City Council.

I recommend passage of the accompanying Order.

Very truly yours,

A handwritten signature in black ink that reads "Kimberley Driscoll".

Kimberley Driscoll
Mayor



CITY OF SALEM

In City Council,

Ordered:

April 14, 2022

Per MGL Chapter 44 Section 64 which allows for a municipality to pay for prior fiscal year invoices using current fiscal year appropriations by two-thirds vote of the City Council we request the sum of Seven Hundred Fifty Dollars (\$750.00) of outstanding Fiscal Year 2021 invoices is hereby allowed to be paid from the Fiscal Year 2022 Police Department budget as listed below in accordance with the recommendation of Her Honor the Mayor.

| Department | Vendor | Amount |
|--------------|------------------------|------------------|
| Police | Essex County Craftsmen | \$ 750.00 |
| Total | | \$ 750.00 |



CITY OF SALEM, MASSACHUSETTS

**Kimberley Driscoll
Mayor**

April 14, 2022

To the City Council
City Hall
Salem, Massachusetts

Ladies and Gentlemen of the Council:

Pursuant to M.G. L. Chapter 44, section 64, enclosed herewith is a request to authorize the payment of the below described Fiscal Year 2021 invoice from the Fiscal Year 2022 Police Department budget.

This invoice was not received by June 30, 2021, the end of the fiscal year.

| <u>Department</u> | <u>Vendor</u> | <u>Amount</u> |
|-------------------|------------------------|---------------|
| Police | Essex County Craftsmen | \$750.00 |

M.G.L. Chapter 44, section 64 allows a municipality to pay for prior fiscal year invoices using current fiscal year appropriations by a two-thirds vote of the City Council.

I recommend passage of the accompanying Order.

Very truly yours,

Handwritten signature of Kimberley Driscoll in black ink.

Kimberley Driscoll
Mayor



CHIEF OF POLICE
LUCAS J. MILLER

City of Salem, Massachusetts
Police Department Headquarters
95 Margin Street
Salem, Massachusetts 01970
(978) 744-2204

March 23, 2022

Mayor Kimberley Driscoll
Salem City Hall
93 Washington Street
Salem, MA 01970

Re: Essex County Craftsmen's November 2020 Invoice #18656

Dear Mayor Driscoll –

I would like to request the attached invoice in the amount of \$750.00 dated November 5, 2020 be paid out our Fiscal Year 2022 Building Maintenance Budget Line (12102-5300).

An emergency call was placed by our custodian for a water leak and Essex County Craftsmen was called in to fix the problem. The repairs were approved by the Captain. However, due to an oversight, a Purchase Order was never issued and we never received the invoice until January 2022. Our office has spoken with Essex County Craftsmen directly to confirm the work was performed and with our Custodian as well.

Due to the fact that this expense occurred from Fiscal Year 2021, we are requesting the amount be paid from our FY2022 Building Maintenance Budget Line.

Sincerely,

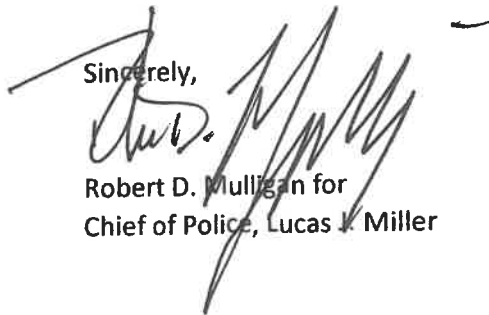
Robert D. Mulligan for
Chief of Police, Lucas J. Miller

RMD: jc
Enclosure



CITY OF SALEM

In City Council,

April 14, 2022

Ordered:

To accept the donation from Friends of the Salem Council on Aging in the amount of Two Thousand Four Hundred Forty-Eight Dollars (\$2,448.00). This donation is to cover expenses for Easter meals for homebound seniors. These funds will be deposited into the COA's Fund 24011-4830 in accordance with the recommendation of Her Honor the Mayor.



CITY OF SALEM, MASSACHUSETTS
Kimberley Driscoll
Mayor

April 14, 2022

Honorable Salem City Council
Salem City Hall
Salem, Massachusetts 01970

Ladies and Gentlemen of the City Council:

Enclosed herewith is a request to accept the following donation from Friends of the Salem Council on Aging in the amount of Two Thousand Four Hundred Forty-Eight Dollars ((\$2,448.00) to be deposited into the Council on Aging Fund 24011-4830. This donation is to cover expenses for Easter meals for homebound seniors.

In order to accept these two donations approval must be given by both the Mayor and City Council. I ask that the members of the City Council join with me in accepting these funds to be used towards the Council on Aging.

Very truly yours,

Kimberley Driscoll
Mayor



CITY OF SALEM, MASSACHUSETTS
PARK, RECREATION & COMMUNITY SERVICES
401 BRIDGE ST., SALEM, MA 01970
(978) 744-0924

KIMBERLEY DRISCOLL
MAYOR

PATRICIA O'BRIEN
SUPERINTENDENT

April 7, 2022

Mayor Kimberley Driscoll
93 Washington Street
Salem, MA 01970

Dear Mayor Driscoll,

The Salem Council on Aging respectfully requests a donation acceptance of \$2,448.00 from the Friends of the Salem COA to be used to pay for Easter meals for homebound or shut-in seniors. As you know, some seniors are isolated without family or a support network. This donation acceptance would allow certain elders the opportunity to receive this special holiday meal delivered by a Friends of the COA volunteer.

Fund 2401
Org/Obj is 24011-4830

Thank you for your consideration.

Sincerely,

Teresa Gove Arnold

Teresa Gove Arnold
Director
Salem Council on Aging



CITY OF SALEM

In City Council,

Ordered:

That the City Council hereby approves the submittal of the City of Salem's Application for Federal Assistance to the United States Department of Housing and Urban Development (HUD) for Community Development Block Grant (CDBG) funds for the period of July 1, 2022 through June 30, 2023 in the amount determined by HUD's formula entitlement allocation (\$968,058 estimated).



CITY OF SALEM, MASSACHUSETTS

Kimberley Driscoll
Mayor

Office of the Mayor

April 14, 2022

Honorable Salem City Council
Salem City Hall
Salem, Massachusetts 01970

Ladies and Gentlemen of the City Council:

Enclosed is an Order authorizing submission of the City's *Application for Federal Assistance* to the U. S. Department of Housing & Urban Development (HUD) for Community Development Block Grant (CDBG) funds for the period of July 1, 2022 through June 30, 2023. For FY23, Salem's estimated CDBG entitlement is \$968,058. In 2020, the City completed its 5-Year Consolidated Plan, outlining Salem's housing, economic and community development needs and funding priorities. In order to receive Federal funds, the City is required to develop Annual Action Plans which put into action the goals and strategies established in the Consolidated Plan.

For the FY23 Action Plan, the process began with a virtual public hearing on January 20, 2022, along with the issuance of a request for funding proposals from agencies to provide housing, economic development and public service programs, and from municipal departments for infrastructure and public facilities improvements. The Draft FY23 Action Plan describes the proposed activities to be undertaken during the upcoming fiscal year. A link to the plan was emailed to you on March 29, 2022. As part of the formal public review process, a 30-day public comment period commenced on March 31st and a virtual public hearing is scheduled for April 21st.

I recommend approval of the application so that it can be transmitted to HUD in a timely manner. Tom Daniel and Jane Guy are available to answer any questions you may have.

Sincerely,

Kimberley Driscoll
Mayor
City of Salem

Salem City Hall • 93 Washington Street • Salem, Massachusetts 01970
p: (978) 619-5600 • f: (978) 744-9327 • www.salem.com/mayor

Application for Federal Assistance SF-424

| | | |
|----------------------------------------------------------------------------------------------------------------------------------------------------------------------------------|----------------------------------------------------------------------------------------------------------------------------------------------------|--------------------------------------------------------------------------------------|
| * 1. Type of Submission: <input type="checkbox"/> Preapplication <input checked="" type="checkbox"/> Application <input type="checkbox"/> Changed/Corrected Application | * 2. Type of Application: <input checked="" type="checkbox"/> New <input type="checkbox"/> Continuation <input type="checkbox"/> Revision | * If Revision, select appropriate letter(s): _____ * Other (Specify): _____ |
|----------------------------------------------------------------------------------------------------------------------------------------------------------------------------------|----------------------------------------------------------------------------------------------------------------------------------------------------|--------------------------------------------------------------------------------------|

| | |
|------------------------------|----------------------------------------|
| * 3. Date Received: _____ | 4. Applicant Identifier: 04-6001413 |
|------------------------------|----------------------------------------|

| | |
|-----------------------------------------|----------------------------------------|
| 5a. Federal Entity Identifier: _____ | 5b. Federal Award Identifier: _____ |
|-----------------------------------------|----------------------------------------|

State Use Only:

| | |
|----------------------------------|----------------------------------------|
| 6. Date Received by State: _____ | 7. State Application Identifier: _____ |
|----------------------------------|----------------------------------------|

8. APPLICANT INFORMATION:

* a. Legal Name: City of Salem

| | |
|-----------------------------------------------------------------------|---------------------------|
| * b. Employer/Taxpayer Identification Number (EIN/TIN): 04-6001413 | * c. UEI: EK46K38N6GH6 |
|-----------------------------------------------------------------------|---------------------------|

d. Address:

* Street1: 98 Washington Street
Street2: _____
* City: Salem
County/Parish: _____
* State: MA: Massachusetts
Province: _____
* Country: USA: UNITED STATES
* Zip / Postal Code: 01970/3526

e. Organizational Unit:

| | |
|----------------------------------------------------|-------------------------|
| Department Name: Planning & Community Developme | Division Name: _____ |
|----------------------------------------------------|-------------------------|

f. Name and contact information of person to be contacted on matters involving this application:

Prefix: Mr. * First Name: Tom
Middle Name: _____
* Last Name: Daniel
Suffix: _____
Title: Director

Organizational Affiliation:
City of Salem, Dept. of Planning & Community Development

| | |
|----------------------------------|-------------------|
| * Telephone Number: 978-619-5685 | Fax Number: _____ |
|----------------------------------|-------------------|

* Email: tdaniel@salem.com

Application for Federal Assistance SF-424

*** 9. Type of Applicant 1: Select Applicant Type:**

C: City or Township Government

Type of Applicant 2: Select Applicant Type:

Type of Applicant 3: Select Applicant Type:

*** Other (specify):**

*** 10. Name of Federal Agency:**

U.S. Department of Housing & Urban Development

11. Catalog of Federal Domestic Assistance Number:

14-218

CFDA Title:

Community Development Block Grant

*** 12. Funding Opportunity Number:**

14-218

*** Title:**

CDBG Program

13. Competition Identification Number:

Title:

14. Areas Affected by Project (Cities, Counties, States, etc.):

Add Attachment

Delete Attachment

View Attachment

*** 15. Descriptive Title of Applicant's Project:**

Community Development Block Grant Program

Attach supporting documents as specified in agency instructions.

Add Attachments

Delete Attachments

View Attachments

Application for Federal Assistance SF-424

16. Congressional Districts Of:

* a. Applicant

* b. Program/Project

Attach an additional list of Program/Project Congressional Districts if needed.

17. Proposed Project:

* a. Start Date:

* b. End Date:

18. Estimated Funding (\$):

| | |
|---------------------|-------------------------------------------|
| * a. Federal | <input type="text" value="968,058.00"/> |
| * b. Applicant | <input type="text"/> |
| * c. State | <input type="text"/> |
| * d. Local | <input type="text"/> |
| * e. Other | <input type="text"/> |
| * f. Program Income | <input type="text" value="125,000.00"/> |
| * g. TOTAL | <input type="text" value="1,093,058.00"/> |

*** 19. Is Application Subject to Review By State Under Executive Order 12372 Process?**

- a. This application was made available to the State under the Executive Order 12372 Process for review on
- b. Program is subject to E.O. 12372 but has not been selected by the State for review.
- c. Program is not covered by E.O. 12372.

*** 20. Is the Applicant Delinquent On Any Federal Debt? (If "Yes," provide explanation in attachment.)**

Yes No

If "Yes", provide explanation and attach

21. *By signing this application, I certify (1) to the statements contained in the list of certifications and (2) that the statements herein are true, complete and accurate to the best of my knowledge. I also provide the required assurances** and agree to comply with any resulting terms if I accept an award. I am aware that any false, fictitious, or fraudulent statements or claims may subject me to criminal, civil, or administrative penalties. (U.S. Code, Title 218, Section 1001)**

** I AGREE

** The list of certifications and assurances, or an internet site where you may obtain this list, is contained in the announcement or agency specific instructions.

Authorized Representative:

Prefix: * First Name:
Middle Name:
* Last Name:
Suffix:

* Title:

* Telephone Number: Fax Number:

* Email:

* Signature of Authorized Representative:

* Date Signed:



Resolution

Authorizing Submission of a Statement of Interest to the Massachusetts School Building Authority

Having convened in an open meeting on April 14, 2022, prior to the SOI submission closing date, the **City Council of the City of Salem, Massachusetts**, in accordance with its charter, by-laws, and ordinances, has voted to authorize the Superintendent to submit to the Massachusetts School Building Authority the Statement of Interest Form dated **April 2022** for the **Salem High School** located at **77 Willson Street, Salem, Massachusetts**, which describes and explains the following deficiencies and the priority categories for which an application may be submitted to the Massachusetts School Building Authority in the future:

Priority 1. Replacement or renovation of a building in a condition seriously jeopardizing the health and safety of school children. A significant portion of the building's heating and ventilation system components have either failed, exceeded their useful life, and/or are predicted to fail imminently. In addition, the building contains significant amounts of asbestos. As the building ages and requires more repair and maintenance, the likelihood of damage to asbestos containing materials and the release of asbestos into the school environment is expected to increase.

Priority 5. Replacement, renovation, or modernization of school facility systems, such as roofs, windows, boilers, heating and ventilation systems, to increase energy conservation and decrease energy related costs. As noted above, a significant portion of the building's systems (including roofs, windows, boilers, and HVAC systems) have exceeded their useful life. In addition, automated building control systems no longer function properly requiring frequent manual adjustment of mechanical equipment, significantly impeding our ability to manage and control energy use.

Priority 7. Replacement of or addition to obsolete buildings in order to provide for a full range of programs consistent with state and approved local requirements. Over 50% of Salem High School students are currently enrolled in CVTE classes. The demand for programs that are relevant to our community, region, and state employers is growing tremendously. Unfortunately, the building as presently designed and equipped is unable to support the expansion of programs that would meet state requirements for CVTE certification. In addition, the constraints of the building prevent the district from providing a full range of programs in the fine and performing arts, and in the science, technology and engineering areas;

and hereby further specifically acknowledges that by submitting this Statement of Interest Form, the Massachusetts School Building Authority in no way guarantees the acceptance or the approval of an application, the awarding of a grant or any other funding commitment from the Massachusetts School Building Authority, or commits the **City of Salem, Massachusetts** to filing an application for funding with the Massachusetts School Building Authority.



CITY OF SALEM, MASSACHUSETTS

Kimberley Driscoll
Mayor

Office of the Mayor

April 14, 2022

Honorable Salem City Council
Salem City Hall
Salem, Massachusetts 01970

Ladies and Gentlemen of the City Council:

The enclosed resolution expresses support for the Superintendent of the Salem Public Schools to submit a Statement of Interest (SOI) to the Massachusetts School Building Authority (MSBA).

The SOI outlines and formalizes the City's intention to seek MSBA funding for Phase 2 of the Salem High School. The SOI is a routine measure that the MSBA requires from both the School Committee and the City Council in order for the district to be eligible to apply for funding.

While a SOI is a prerequisite condition for applying for funding, it in no way guarantees that our application to the MSBA will be approved or that funding will be provided. It also does not commit the district or the City to budgeting or expending any funds for this project at this time.

In the interest of keeping our school buildings and renovation program moving forward in a positive direction and on the timetable laid out by the MSBA, I strongly encourage support for this resolution, which is a requirement for the MSBA to consider our SOI. The MSBA requires the SOI be submitted before the close of business on April 29; therefore, I am requesting the City Council vote on these resolutions at your meeting of April 14.

Sincerely,

Kimberley Driscoll
Mayor
City of Salem

City of Salem

In the year Two Thousand and Twenty-Two

An Ordinance to amend language relative to the senior resident tax work off abatement program.

Section 1. Section 2-2052 *Program guidelines* of Chapter 2 Administration is hereby amended in subsection (a) by deleting the number "\$1,000.00" and replacing it with the number "\$1,500.00".

Section 2. Section 2-2052 *Program guidelines* of Chapter 2 Administration is hereby amended in subsection (d) by deleting the number "30" and replacing it with the number "60".

Section 3. This Ordinance shall take effect as provided by City Charter.



CITY OF SALEM, MASSACHUSETTS

Kimberley Driscoll
Mayor

Office of the Mayor

April 14, 2022

Honorable Salem City Council
Salem City Hall
Salem, Massachusetts 01970

Ladies and Gentlemen of the City Council:

The enclosed Ordinances corrects the section of our Code regarding the senior property tax work-off program to ensure the language in the Ordinance is consistent with previously adopted Council Orders.

Specifically, in 2017 the Council voted to increase the amount available under the program to \$1,500 per person. This change was only adopted by Order, however, therefore an Ordinance is required to make the adjustment in the Code.

Additionally, a previously adopted Ordinance updated the maximum number of potential participants in the program from 30 to 60 individuals; however, it was only updated in one of the two parts of the Ordinance that reference the figure. The enclosed Ordinance corrects this so that both parts of the section refer to 60 individuals.

I recommend adoption of the enclosed Ordinance. If you have any questions regarding this request, please feel free to contact Kathleen McCarthy at the Department of Parks, Recreation, and Community Services.

Sincerely,

Kimberley Driscoll
Mayor
City of Salem



CITY OF SALEM, MASSACHUSETTS
PARK, RECREATION AND COMMUNITY SERVICES
401 BRIDGE ST., SALEM, MA 01970
(978) 744-0924

March 30, 2022

Honorable Kimberley Driscoll
Mayor, City of Salem
Salem City Hall
Salem, Massachusetts 01970

Dear Mayor Driscoll:

Representing the City of Salem Council on Aging, I am requesting that certain language relative to the senior tax work off abatement program be amended. In 2017, the Council voted to increase the amount available under the program to \$1,500 per person. This change was only adopted by Order. We realize that an Ordinance is required to make the adjustment in the Code. In addition, a previously adopted Ordinance updated the maximum number of potential participants in the program from 30 to 60 individuals; however, it was only updated in one of the two parts of the Ordinance that reference the figure. I respectfully request that the language in the Ordinance be consistent with previously adopted Council Orders as reflected below:

An Ordinance to amend language relative to the senior resident tax work off abatement program.

Section 1. Section 2-2052 *Program guidelines* of Chapter 2 Administration is hereby amended in subsection (a) by deleting the number "\$1,000.00" and replacing it with the number "\$1,500.00".

Section 2. Section 2-2052 *Program guidelines* of Chapter 2 Administration is hereby amended in subsection (d) by deleting the number "30" and replacing it with the number "60".

Section 3. This Ordinance shall take effect as provided by City Charter.

If you have any questions regarding this request, please feel free to contact me or Kathleen McCarthy at the Department of Parks, Recreation, and Community Services. Thank you.

Sincerely,

A handwritten signature in cursive script that reads "Teresa Gove Arnold".

Teresa Gove Arnold
Director, Salem Council on Aging

City of Salem

In the year Two Thousand and Twenty-Two

An Ordinance to ensure a more inclusive municipal Code of Ordinances.

Section 1. Section 2-532 – *Qualifications* of Chapter 2 is hereby amended by replacing the word “citizen” with the word “resident”.

Section 2. Article XV. – *Senior Citizen Tax Work Off Abatement Program* of Chapter 2 is hereby amended in the Article title by replacing the word “Citizen” with the word “Property-Owner”

Section 3. Section 2-1733 – *General duties* of Chapter 2 is hereby amended by replacing the word “citizen” with the word “individual”.

Section 4. Section 14-402 – *Issuance of licenses* of Chapter 14 is hereby amended by replacing the word “citizens” with the word “residents”.

Section 5. Section 24-4 – *Discharging firearms* of Chapter 24 is hereby amended by replacing the word “citizen” with the word “individual.”

Section 6. Section 26-66 – *Purpose and goals* of Chapter 26 is hereby amended in subsection (a) by replacing the word “citizens” with the word “residents” in both instances in which it appears in the subsection.

Section 7. Section 30-30 – *General duties* of Chapter 30 is hereby amended by replacing the word “citizens” with the word “residents.”

Section 8. Section 32-19 – *Constables* of Chapter 32 is hereby amended in subsection (b) by replacing the word “citizens” with the word “residents”.

Section 9. Section 32-130 – *Preamble* of Chapter 32 is hereby amended by replacing the word “citizens” with the word “residents”.

Section 10. Section 32-122 – *Legislative findings* of Chapter 32 is hereby amended in subsection (a) by replacing the word “citizen” with the word “individual” and by adding at the end of subsection (a) “to the extent permitted by law.”

Section 11. This Ordinance shall take effect as provided by City Charter.



CITY OF SALEM, MASSACHUSETTS

Kimberley Driscoll
Mayor

April 14, 2022

Honorable Salem City Council
Salem City Hall
Salem, Massachusetts 01970

Ladies and Gentlemen of the City Council:

Last year the City updated our Code of Ordinances to ensure gender neutral language and thereby make it more applicable to all persons. In our effort to further ensure that the language in our local laws is inclusive, the enclosed Ordinance has been drafted to change instances of the word "citizen," except in those places where the language intends to apply specifically to someone of that legal standard.

The enclosed Ordinance does not modify the intention or substance of any of the sections that are included. Rather, it replaces, in ten parts of the Code, the word "citizen" with "resident," "individual," or "property owner" depending on the context within which the word "citizen" appears in that section. "Citizen" connotes an individual with specific legal standing, namely United States citizenship. However, these sections of our Code are broadly applicable to any person, or any Salem resident, regardless of their citizenship status, and therefore the language used should reflect that. We are similarly encouraging City departments to be more thoughtful in the use of the word "citizen" in their documents, when they may actually mean "resident."

In 2017 Salem adopted an ordinance that observed that our city "desires to maintain and foster a culture and environment where our immigrant and refugee residents can fully participate in and be integrated into the social, civic, and economic fabric of their adopted city." That same ordinance directed that "City employees shall serve all residents and city services shall be accessible to all residents, regardless of immigration status." While the language changes within this proposed Ordinance may be considered symbolic by some, I view them as a continuation of the commitments and requirements of the 2017 ordinance and therefore recommend its adoption.

Sincerely,

Kimberley Driscoll
Mayor
City of Salem

Section 1.

ARTICLE XV. - SENIOR CITIZEN PROPERTY-OWNER TAX WORK OFF ABATEMENT PROGRAM

Section 2.

Sec. 2-532. - Qualifications.

The city physician shall be a citizen **resident** of the city and a graduate of a legally incorporated medical school.

Section 3.

Sec. 2-1733. - General duties.

The city purchasing agent shall be the chief procurement officer of the city and as such shall have charge of the city purchasing department and shall purchase all supplies and services for the city or any department thereof, except in an emergency. The purchasing agent shall sell all supplies or materials, whether new or old, that are not needed by the city or any department thereof. The purchasing agent shall keep a record of the prices paid for all materials and supplies. Such record shall be open to the inspection of any citizen **individual**. Each year the city purchasing agent shall at the proper time undertake a collective purchase of clerical supplies for all city departments, except the school department. The city purchasing agent shall act under the direction of the finance director/auditor.

Section 4.

Sec. 14-402. - Issuance of licenses.

The board shall grant a license applied for under this division unless the board specifically finds, after a hearing preceded by at least ten days' written notice to the applicant and states in writing within 30 days next following the close of such hearing that the granting of the license at the premises would lead to or cause an offense under any applicable law, code, or ordinance; or would lead to the creation of a nuisance or otherwise endanger the public health, safety, or order by:

- (1) Unreasonably increasing pedestrians or vehicular traffic in the area in which the premises are located; or
- (2) Increasing the incidence of illegal or disruptive conduct in the area in which the premises are located; or
- (3) Unreasonably increasing the level of noise in the area in which the premises are located; or
- (4) Otherwise significantly harming the legitimate protected interests of the affected citizens **residents** of the city.

The board shall consider City Ordinance Chapter 22 (Noise Control), Chapter 14, Article IV (Hours of Operation) and any other relevant local or state laws or regulations when making its decision. The board shall adopt rules and standard conditions for the issuance of license for theatrical exhibitions, public shows, public amusements, concert, dances, cabarets, and exhibitions of every description pursuant to M.G.L.A. c. 140, § 183A. In addition, the board may impose additional conditions upon a license, but said conditions may only relate to compliance with applicable laws or ordinances, or to public safety, health, or order, or to steps required to be taken to guard against creation of a nuisance or to insure adequate safety and security for patrons of the affected public.

Section 5.

Sec. 24-4. - Discharging firearms.

No person shall, except as authorized or required by law, fire or discharge any pistol, rifle or shotgun in the city. This section shall not apply to:

- (1) The performance by the marshal or other police officers of their duties.
 - (2) The use of such weapons at any military exercise or at an established rifle range.
 - (3) The lawful defense of the person, family or property of any citizen **individual**.
 - (4) The exercise within the confines of the city's police jurisdiction of the rights and privileges of an owner or lessee of land as set forth in M.G.L.A. c. 131, including coastal duck hunting. However, this subsection shall apply to all waters on the inland side of Lafayette Street and on the seaward side of Lafayette from Pickering Point at Forest River Park to the nearest point along Salem-Marblehead corporation boundary line in Salem Harbor, which area specifically includes Jeggles Island, and as shown as hatched area on the copy of a portion of the 1970 U.S. Geologic Map on file in the city offices.
-

Section 6.

Sec. 26-66. - Purpose and goals.

(a) The Salem Common is for the use and enjoyment of the citizens **residents** of the city and its visitors. Activities on the common should not interfere or disturb the peace and enjoyment of all the citizens **residents** of the city.

(b) The goals of this policy are to:

(1) Protect the common from adverse wear and tear.

(2) Maintain handicapped accessibility.

(3) Promote the following:

a. Activities which are open to the public for public enjoyment.

b. Passive recreation.

c. Activities which develop public awareness and maintenance of the common.

(c) No activities which will cause damage to the Salem Common will be allowed under any circumstances.

(d) The park and recreation commission shall have sole authority over administering this article and issuing permits for the use of the Salem Common. The police department and the superintendent of parks/recreation and community service director shall have the authority to enforce this article. Under the provisions of this article, the Salem Park and Recreation Commission is hereby designated as the permit agent for the city council. Nothing in this article shall be construed as transferring the statutory jurisdiction of the Salem Common from the Salem City Council to the Salem Park and Recreation Commission.

Section 7.

Sec. 30-30. - General duties.

In addition to the duties prescribed by statute, it shall be the duty of the planning board to study and from time to time point out to the city council such physical improvements as may be deemed desirable, such as the changing of grades and lines of existing streets, the laying out of new streets, ways and squares; the preservation of historical landmarks; the location of statuary, monuments or other works of art; the improvement of the harbor and waterfront; and in general to point out to the city council such recommendations for the industrial, commercial and civic development of the city as may seem for the best interests of the city and its citizens **residents**.

Section 8.

Sec. 32-19. - Constables.

(a) Pursuant to M.G.L.A. ch. 41, § 91, the mayor may appoint constables. Such appointments shall be made for a term not exceeding three years. An application for appointment as constable shall be accompanied by a non-refundable application fee of \$100.00 for first-time applicants to cover the city's cost of processing. There shall also be a fee of \$50.00 for each year of the appointment, payable to the city upon application which shall be refunded in the event the application is not approved. The total number of constables at any one time shall not exceed 100. No fees shall apply to any city employees who are appointed to serve as constables as a part of their city jobs.

(b) Applicants for constable must be at least 21 years of age and submit a written resume and completed application to the mayor containing such information reasonably required by the city for use in determining the fitness, reputation and character of the applicant to hold the office of constable. Proof of appropriate training and/or experience shall be required as a part of this determination. All applicants for appointment or reappointment as constable shall, as part of the application, consent in writing to a background investigation and a Criminal Offender Record Information (CORI) report. These application materials shall be forwarded to the police chief who shall conduct an investigation and make a recommendation to the mayor as to the individual's fitness to serve as a constable. Pursuant to M.G.L.A. ch. 41, § 91B, the application shall include a statement as to the moral character of the applicant signed by a minimum of five citizens **residents** of the community in which the applicant resides, one of whom must be an attorney. All constables shall also be subject to the fingerprinting requirements of section 14-46, and shall, once appointed, receive a photo identification badge issued by the police department.

(c) Prior to appointment, a constable must obtain and submit to the city clerk a surety bond in the amount of \$5,000.00 pursuant to the provisions of M.G.L.A ch. 41, § 92. Said bond shall be maintained throughout the term of the constable's appointment.

(d) Constables appointed pursuant to this ordinance shall be subject at all times to the orders as well as any rules and regulations pertaining to constables issued by the police chief. No constable appointed by the city shall wear a uniform similar to that of the appointed officers of the city's police department, or to that of any other appointed police officers within the Commonwealth, or otherwise attempt to present themselves as an appointed police officer. A constable who possesses a valid license to carry a firearm shall comply with all laws and regulations governing the use and possession of firearms. The mayor may, with the approval of the city council, revoke the appointment of a constable for gross misconduct. Gross misconduct shall include, but not be limited to: (1) failure to follow the police chief's orders; (2) violation of the rules and

regulations governing constables; (3) violation of any provision of this section; and (4) criminal acts in violation of the laws of the United States or any local jurisdiction.

Section 9.

Sec. 32-130. - Preamble.

WHEREAS, the City Council seeks to promote the health, safety and welfare of the citizens **residents** of the City of Salem; and

WHEREAS, pursuant to the Home Rule Amendment to the Massachusetts Constitution, article II, section 6, and the Massachusetts General Laws Chapter 43B, section 13, the City may adopt, amend or repeal local ordinances or by-laws not inconsistent with the constitution or the laws enacted by the general court; and

WHEREAS, pursuant to Massachusetts General Laws Chapter 89, section 9, the City may enact local ordinances or by-laws designating intersections at which vehicular traffic shall stop before entering the intersection, and may erect and maintain traffic control devices; and

WHEREAS, pursuant to Massachusetts General Laws Chapter 90C, section 3, if a police officer observes or has brought to the officer's attention the occurrence of a civil motor vehicle infraction, the officer may issue a written warning or may cite the violator for a civil motor vehicle infraction; and

WHEREAS, pursuant to Massachusetts General Laws Chapter 90C, section 2, a police officer shall record the occurrence of an automobile law violation upon a citation, whether or not the offense occurs within the police officer's presence; and

WHEREAS, pursuant to Massachusetts General Laws Chapter 90C, section 2, where a violator of a traffic ordinance or by-law could not have been stopped or where additional time was reasonably necessary to determine the nature of the violation or the identity of the violator, or where the court finds that a circumstance justifies, a police officer may issue a written citation by mail; and

WHEREAS, pursuant to Massachusetts General Laws Chapter 89, section 9, except when directed to proceed by a police officer, every driver of a vehicle approaching a stop sign or a flashing red signal indication shall stop at a clearly marked stop line; and

WHEREAS, pursuant to Massachusetts General Laws Chapter 90, section 17, no person operating a motor vehicle on any way shall run it at a rate of speed greater than is reasonable and proper; and

WHEREAS, the City's concern over traffic accidents and related fatalities resulting from motorists running red lights and speeding is a legitimate public safety concern of the City which demands the implementation of reasonable regulations; and

WHEREAS, *Automated Photographic Traffic Enforcement Systems* help to bolster and support the efforts of the City's law enforcement personnel in enforcing the City's traffic rules and regulations; and

WHEREAS, it is the intent and purpose of this ordinance to increase safety, decrease fatalities, increase motorist's consciousness, and reduce property loss due to motorists running red lights and speeding.

NOW, THEREFORE, BE IT ORDANED BY THE CITY COUNCIL OF THE CITY OF SALEM, MASSACHUSETTS that the police department is hereby authorized to implement systems to enforce local traffic rules, ordinances, and by-laws with the use of automated photographic traffic control devices that will record photographic images as prima facie evidence of traffic violations and will authorize the police department to issue civil citations and warning notices, or an agent thereof to perform ministerial functions with respect to the issuance of civil citations and warning notices for the violations.

Section 10.

Sec. 32-112. - Legislative findings.

(a) The city council hereby finds and declares that it is the right of every person, regardless of race, color, creed, religion, national origin, sex, age, or disability to be secure and protected from fear, intimidation and physical harm caused by the activities of violent groups and individuals. It is not the intent of this article to interfere with the exercise of the constitutionally protected rights of freedom of expression and association. The city council hereby recognizes the constitutional right of every citizen **individual** to harbor and express beliefs on any lawful subject whatsoever, to lawfully associate with others who share similar beliefs, to petition lawfully constituted authority for a redress of perceived grievances, and to participate in the electoral process **to the extent permitted by law.**

(b) The city council finds, however, that certain neighborhoods and public places throughout the city are negatively impacted by street gangs.

(c) The council further finds that it is prudent to institute reasonable laws so as to make it a violation of a city ordinance to solicit or recruit; conspire to solicit or recruit a juvenile as a member of a criminal street gang or to deter a juvenile from leaving a criminal street gang.

(1) Unreasonably increasing pedestrians or vehicular traffic in the area in which the premises are located; or

(2) Increasing the incidence of illegal or disruptive conduct in the area in which the premises are located; or

(3) Unreasonably increasing the level of noise in the area in which the premises are located; or

(4) Otherwise significantly harming the legitimate protected interests of the affected citizens **residents** of the city.

The board shall consider City Ordinance Chapter 22 (Noise Control), Chapter 14, Article IV (Hours of Operation) and any other relevant local or state laws or regulations when making its decision. The board shall adopt rules and standard conditions for the issuance of license for theatrical exhibitions, public shows, public amusements, concert, dances, cabarets, and exhibitions of every description pursuant to M.G.L.A. c. 140, § 183A. In addition, the board may impose additional conditions upon a license, but said conditions may only relate to compliance with applicable laws or ordinances, or to public safety, health, or order, or to steps required to be taken to guard against creation of a nuisance or to insure adequate safety and security for patrons of the affected public.

Section 5.

Sec. 24-4. - Discharging firearms.

No person shall, except as authorized or required by law, fire or discharge any pistol, rifle or shotgun in the city. This section shall not apply to:

(1) The performance by the marshal or other police officers of their duties.

(2) The use of such weapons at any military exercise or at an established rifle range.

(3) The lawful defense of the person, family or property of any citizen **individual**.

(4) The exercise within the confines of the city's police jurisdiction of the rights and privileges of an owner or lessee of land as set forth in M.G.L.A. c. 131, including coastal duck hunting. However, this subsection shall apply to all waters on the inland side of Lafayette Street and on the seaward side of Lafayette from Pickering Point at Forest River Park to the nearest point along Salem-Marblehead corporation boundary line in Salem Harbor, which area specifically includes Jeggles Island, and as shown as hatched area on the copy of a portion of the 1970 U.S. Geologic Map on file in the city offices.



CITY OF SALEM

In City Council, April 14, 2022

Ordered: The Mayor is hereby authorized to convey, through an inter-governmental transfer, to the Salem Redevelopment Authority a 300 square foot portion of the City-owned right of way that encompasses the stairs from Bridge Street to the Crescent Lot at 252 Bridge Street as shown on the Plan of Land entitled "252 Bridge Street," prepared by Hancock Associates, 185 Centre Street, Danvers, MA 01923, and dated 3/4/2022, and previously declared surplus property by the City Council.



CITY OF SALEM, MASSACHUSETTS
Kimberley Driscoll
Mayor

April 14, 2022

Honorable Salem City Council
City Hall
Salem, Massachusetts 01970

RE: Intergovernmental Transfer of Portion of Public Right of Way next to Crescent Parking Lot at Commuter Rail Station

Ladies and Gentlemen of the City Council:

On March 24, 2022, the City Council discussed and agreed to surplus and intergovernmentally transfer a 300 square foot area where the Crescent Parking Lot stairway is located to the Salem Redevelopment Authority (SRA). The action involved two orders—first to declare the parcel surplus and second to transfer the parcel to the SRA. The second order was missing from the Council packet and is enclosed herewith.

Sincerely,

A handwritten signature in cursive script that reads "Kimberley Driscoll".

Kimberley Driscoll
Mayor



CITY OF SALEM

In City Council, April 14, 2022

Ordered: Pursuant to Section 32-121 of the Code of Ordinances the Salem Police Department is hereby authorized and approved to place video surveillance equipment in the following locations:

- (a) Lafayette Street and Loring Avenue intersection
- (b) North Street and Highland Street intersection
- (c) Loring Avenue and Maple Avenue intersection
- (d) Salem Fire Station, 142 North Street
- (e) Chief James F. Brennan Memorial Fire Headquarters, 48 Lafayette Street
- (f) Joseph A. O'Keefe Memorial Fire Station, 64 Loring Avenue
- (g) Salem Fire Station, 415 Essex Street
- (h) 318 Essex Street adjacent to the Essex Street and North Street intersection



CITY OF SALEM, MASSACHUSETTS

Kimberley Driscoll
Mayor

Office of the Mayor

April 14, 2022

Honorable Salem City Council
Salem City Hall
Salem, Massachusetts 01970

Ladies and Gentlemen of the City Council:

The enclosed Order authorizes the Salem Police Department to install video cameras in locations as specified in the enclosed letter from Chief Lucas Miller and summarized below. Council authorization is required for these camera installations pursuant to Section 32-121 of the Code of Ordinances.

- Lafayette Street and Loring Avenue intersection
- North Street and Highland Street intersection
- Loring Avenue and Maple Avenue intersection
- Essex Street and North Street intersection
- Salem Fire Department station exteriors at North Street, Lafayette Street, Loring Avenue, and Essex Street

I recommend adoption of the enclosed Order. If you have any questions regarding this request, please feel free to contact Chief Lucas Miller.

Sincerely,

Kimberley Driscoll
Mayor
City of Salem



City of Salem, Massachusetts

Police Department Headquarters

95 Margin Street

Salem, Massachusetts 01970

(978) 744-2204

CHIEF OF POLICE

LUCAS J. MILLER

March 21, 2022

Salem City Council
93 Washington Street
Salem, Massachusetts 01970

Dear City Council Members,

In accordance with Chapter 32, Article 5, Section 32-121 of the Code of Ordinances of the City of Salem, the Salem Police Department respectfully requests authority to install video surveillance camera at the following locations:

Installation of cameras at the intersection of Lafayette Street and Loring Avenue allowing the Department the ability to monitor the traffic congestion and deter criminal activity.

Installation of a camera at the intersection of North Street and Highland Street (Salem/Peabody line) allowing the Department to monitor traffic and capture vehicle license plates to monitor the traffic congestion and deter criminal activity. This project is partially funded (75%) from the 2021 Port Security Grant.

Installation of a camera at the intersection of Loring Avenue and Maple Avenue (Salem/Swampscott line) allowing the Department to monitor traffic and capture vehicle license plates to monitor the traffic congestion and deter criminal activity. This project is partially funded (75%) from the 2021 Port Security Grant.

Installation of cameras in front of the four (4) fire stations (North Street, Lafayette Street, Loring Ave, and Essex Street) allowing the Department to monitor traffic and assist in security of the election ballot boxes.

Installation of cameras at 318 Essex Street allowing the Department the ability to monitor the traffic congestion and deter criminal activity in the area of Essex Street and North Street especially during special events (i.e. July 4th, Halloween, etc.). This project is a joint effort with the Peabody Essex Museum.

Per the Ordinance, the above listed security cameras will record video feed only: audio recording will not be conducted. Additionally, public notice of the installation and operation of video cameras will be published on social media.

It is my belief that installation of video surveillance cameras at the above locations will assist this Department in preventing criminal acts and should such acts occur, enable us to respond in a timely manner to take appropriate action.

Sincerely,

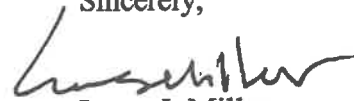
A handwritten signature in black ink, appearing to read 'Lucas J. Miller', written in a cursive style.

Lucas J. Miller
Chief of Police



CITY OF SALEM, MASSACHUSETTS

Kimberley Driscoll
Mayor

Office of the Mayor

April 14, 2022

Honorable Salem City Council
Salem City Hall
Salem, Massachusetts 01970

Ladies and Gentlemen of the City Council:

I am writing to request that the City Council's Committee of the Whole convene later in April so that City staff working on our American Rescue Plan Act (ARPA) program can provide a public update on the work undertaken to date and the plan moving forward to leverage our first round of ARPA funds for a robust recovery from the pandemic.

Presenters will include David Rodrigues (Director of Recovery Strategy and Initiatives), Nick Downing (Federal Funds Manager), Anna Freedman (Finance Director), and Dominick Pangallo (Chief of Staff).

We look forward to the opportunity to share details about the thoughtful and responsive plan that has been put together based on public feedback from surveys and forums, a careful review of local needs and existing priorities and plans, and the input of a broad group of community stakeholders.

Sincerely,

Kimberley Driscoll
Mayor
City of Salem



CITY OF SALEM

In City Council April 14, 2022

ORDERED: That the Veteran's Agent raise the Polish Flag in Riley Plaza on May 3, 2022 at 11:30 AM in honor of Polish Labor Day, Polish Flag Day and Polish Constitution Day.

City of Salem

In the year two thousand and twenty two

An Ordinance *to amend an Ordinance relative to Traffic*

Be it ordained by the City Council of the City of Salem, as follows:

Section 1. Chapter 42 Section 50B – Handicap Zones, Limited Time shall be amended by adding:

Symonds Street – One Handicap Parking space to be added in front of #16 Symonds Street, for a distance of twenty (20) feet

Section II. This Ordinance shall take effect as provided by City Charter.



City of Salem, Massachusetts
Office of the City Council
City Hall



REQUEST FOR TRAFFIC ORDINANCE RECOMMENDATION

MEMO TO: Lt. David Tucker Police Traffic Division
FROM: Councilor Riccardi DATE: April 12, 2022

In accordance with the Council Rule 32A, I hereby request your recommendation for the following Traffic Ordinance:

NAME OF STREET Symonds Street

TYPE OF STREET CHANGE Handicapped Parking, Time Limited

DESCRIPTION OF AREA WHERE CHANGE IS REQUESTED In front of 16 Symonds Street,
one parking space is needed for the disabled resident.

COUNCILLOR'S COMMENTS/EXPLANATION A resident of 16 Symonds Street is disabled and
uses a vehicle in conjunction with an HP placard. Their off-street parking is not adequate and they may
have difficulty finding parking in close proximity to the home. This would cause a hardship due to their
mobility issue.

POLICE TRAFFIC DIVISION RECOMMENDATION

The Police Traffic Division hereby submits the following recommendation for the above request:

APPROVAL
 DENIAL
 TRIAL PERIOD

CHAPTER: 42 SECTION: 50B TITLE: Handicapped Zones, Limited Time

DESCRIPTION: One HP parking space to be added, in front of 16 Symonds Street, for a distance of
twenty (20) feet.

COMMENTS (IF ANY): _____

Lt. David Tucker

POLICE TRAFFIC DIVISION

RETURN THIS FORM TO THE CITY CLERK'S OFFICE

City of Salem Clerk's Office, 93 Washington St. Salem Massachusetts 01970

(978) 745-9595 ext 41202 www.salem.com

City of Salem

In the year Two Thousand and Twenty-Two

An Ordinance Relative to Traffic

Be it ordained by the City Council of the City of Salem, as follows:

Section 1. Article I is hereby amended by repealing the following to Section 17A:

Section 50 - Prohibited in certain specified places. Within Ten Feet of a Fire Hydrant \$50

Section 50 - Prohibited in certain specified places. Upon a Crosswalk \$25

Section 50 - Prohibited in certain specified places. Upon a sidewalk \$25

Section 50 - Prohibited in certain specified places. Within Four Feet of Driveway or Private Road \$15

Section 52. - Bus stops. Bus Stop \$15

Section 75 - \$15.00 Fine/\$40.00 Fine on Friday, Saturday and Sunday during Month of October for violation of Parking Prohibitions Towing Zone (Resident Sticker)

Section 75A – Parking Prohibitions towing zone (October Resident Parking) – \$50

And replacing it with:

Section 50 - Prohibited in certain specified places. Within Ten Feet of a Fire Hydrant \$50.00 Fine/\$75.00 Fine during Month of October

Section 50 - Prohibited in certain specified places. Upon a Crosswalk \$25.00 Fine/\$75.00 Fine during Month of October

Section 50 - Prohibited in certain specified places. Upon a sidewalk \$25.00 Fine/\$75.00 Fine during Month of October

Section 50 - Prohibited in certain specified places. Within Four Feet of Driveway or Private Road \$15.00 Fine/\$75.00 Fine during Month of October

Section 52. - Bus stops. Bus Stop \$15.00 Fine/\$75.00 Fine during Month of October

Section 75 - \$15.00 Fine/\$75.00 Fine during Month of October for violation of Parking Prohibitions Towing Zone (Resident Sticker)

Section 75A – \$75.00 Fine Parking Prohibitions towing zone (October Resident Parking)

Section 2. This ordinance shall take effect as provided by City Charter.



City of Salem, Massachusetts
Office of the City Council
City Hall



REQUEST FOR TRAFFIC ORDINANCE RECOMMENDATION

MEMO TO: Lt. David Tucker Police Traffic Division
FROM: Councilor Riccardi DATE: April 12, 2022

In accordance with the Council Rule 32A, I hereby request your recommendation for the following Traffic Ordinance:

NAME OF STREET City-wide

TYPE OF STREET CHANGE Article I, Section 17A – Schedule of Fines Re: Penalties

DESCRIPTION OF AREA WHERE CHANGE IS REQUESTED City-wide, increase of parking fines during the month of October.

COUNCILLOR'S COMMENTS/EXPLANATION In an effort to reduce the increasing number of parking violations during the Halloween season, the Traffic and Parking Commission have recommended an increase in certain parking fines during the month of October. This will ensure that legitimate parking remains the more cost-effective option compared with the cost of a parking violation.

POLICE TRAFFIC DIVISION RECOMMENDATION

The Police Traffic Division hereby submits the following recommendation for the above request:

- APPROVAL
- DENIAL
- TRIAL PERIOD

CHAPTER: 42 SECTION: 17A TITLE: Schedule of Fines Re: Penalties

DESCRIPTION: Repeal the following:
Section 50 - Prohibited in certain specified places. Within Ten Feet of a Fire Hydrant \$50;
Section 50 - Prohibited in certain specified places. Upon a Crosswalk \$25;
Section 50 – Prohibited in certain specified places. Upon a sidewalk \$25;
Section 50 - Prohibited in certain specified places. Within Four Feet of Driveway or Private Road \$15;
Section 52. - Bus stops, Bus Stop \$15;
Section 75 - \$15.00 Fine/\$40.00 Fine on Friday, Saturday and Sunday during Month of October for violation of Parking Prohibitions Towing Zone (Resident Sticker);
Section 75A – Parking Prohibitions towing zone (October Resident Parking) – \$50

Replace with:

Section 50 - Prohibited in certain specified places. Within Ten Feet of a Fire Hydrant \$50.00 Fine/\$75.00

Fine during Month of October:

Section 50 - Prohibited in certain specified places: Upon a Crosswalk \$25.00 Fine/\$75.00 Fine during

Month of October:

Section 50 - Prohibited in certain specified places. Upon a sidewalk \$25.00 Fine/\$75.00 Fine during Month
of October:

Section 50 - Prohibited in certain specified places. Within Four Feet of Driveway or Private Road \$15.00
Fine/\$75.00 Fine during Month of October:

Section 52. - Bus stops. Bus Stop \$15.00 Fine/\$75.00 Fine during Month of October:

Section 75 - \$15.00 Fine/\$75.00 Fine during Month of October for violation of Parking Prohibitions

Towing Zone (Resident Sticker):

Section 75A - \$75.00 Fine Parking Prohibitions towing zone (October Resident Parking) current list of
streets in Section 75A following page.

COMMENTS (IF ANY):



POLICE TRAFFIC DIVISION

RETURN THIS FORM TO THE CITY CLERK'S OFFICE

City of Salem Clerk's Office, 93 Washington St, Salem Massachusetts 01970

(978) 745-9595 ext 41202 www.salem.com

City of Salem

In the year two thousand and twenty two.

An Ordinance to amend an Ordinance relative to Traffic

Be it ordained by the City Council of the City of Salem, as follows:

Section 1. Chapter 42 Section 50B – Handicap Zones, Limited Time shall be amended by adding:

Hersey Street – One Handicap Parking space to be added in front of #18 Hersey Street, for a distance of twenty (20) feet

Section II. This Ordinance shall take effect as provided by City Charter.



City of Salem, Massachusetts
Office of the City Council
City Hall



REQUEST FOR TRAFFIC ORDINANCE RECOMMENDATION

MEMO TO: Lt. David Tucker Police Traffic Division
 FROM: Councilor Cohen DATE: April 12, 2022

In accordance with the Council Rule 32A, I hereby request your recommendation for the following Traffic Ordinance:

NAME OF STREET Hersey Street

TYPE OF STREET CHANGE Handicapped Parking, Time Limited

DESCRIPTION OF AREA WHERE CHANGE IS REQUESTED In front of 18 Hersey Street,
one parking space is needed for the disabled resident.

COUNCILLOR'S COMMENTS/EXPLANATION A resident of 18 Hersey Street is disabled and
uses a vehicle in conjunction with an HP placard. They do not have access to off street parking and may
have difficulty finding parking in close proximity to the home. This would cause a hardship due to their
mobility issue.

POLICE TRAFFIC DIVISION RECOMMENDATION

The Police Traffic Division hereby submits the following recommendation for the above request:

XX APPROVAL
 _____ DENIAL
 _____ TRIAL PERIOD

CHAPTER: 42 SECTION: 50B TITLE: Handicapped Zones, Limited Time

DESCRIPTION: One HP parking space to be added, in front of 18 Hersey Street, for a distance of
twenty (20) feet.

COMMENTS (IF ANY): _____

POLICE TRAFFIC DIVISION

RETURN THIS FORM TO THE CITY CLERK'S OFFICE

City of Salem Clerk's Office, 93 Washington St. Salem Massachusetts 01970

(978) 745-9595 ext 41202 www.salem.com

City of Salem

In the year two thousand and twenty two.

An Ordinance to amend an Ordinance relative to Traffic

Be it ordained by the City Council of the City of Salem, as follows:

Section 1. Chapter 42 Section 50B – Handicap Zones, Limited Time shall be amended by adding:

Chase Street – One Handicap Parking space to be added in front of #14 Chase Street, for a distance of twenty (20) feet

Section II. This Ordinance shall take effect as provided by City Charter.



City of Salem, Massachusetts
Office of the City Council
City Hall



REQUEST FOR TRAFFIC ORDINANCE RECOMMENDATION

MEMO TO: Lt. David Tucker Police Traffic Division
FROM: Councilor Cohen DATE: April 12, 2022

In accordance with the Council Rule 32A, I hereby request your recommendation for the following Traffic Ordinance:

NAME OF STREET Chase Street

TYPE OF STREET CHANGE Handicapped Parking, Time Limited

DESCRIPTION OF AREA WHERE CHANGE IS REQUESTED In front of 14 Chase Street,
one parking space is needed for the disabled resident.

COUNCILLOR'S COMMENTS/EXPLANATION A resident of 14 Chase Street is disabled and
uses a vehicle in conjunction with an HP placard. Their off street parking is limited and causes a
hardship due to their mobility issue.

POLICE TRAFFIC DIVISION RECOMMENDATION

The Police Traffic Division hereby submits the following recommendation for the above request:

- APPROVAL
- DENIAL
- TRIAL PERIOD

CHAPTER: 42 SECTION: 50B TITLE: Handicapped Zones, Limited Time

DESCRIPTION: One HP parking space to be added, in front of 14 Chase Street, for a distance of
twenty (20) feet.

COMMENTS (IF ANY): _____

POLICE TRAFFIC DIVISION

RETURN THIS FORM TO THE CITY CLERK'S OFFICE

City of Salem Clerk's Office, 93 Washington St, Salem Massachusetts 01970

(978) 745-9595 ext 41202 www.salem.com



CITY OF SALEM

In City Council April 14, 2022

ORDERED: That the Committee on Public Health, Safety and Environment meet to discuss enforcement and penalties relative to snow and ice removal



CITY OF SALEM

In City Council April 14, 2022

ORDERED: That the Mayor be invited to a Committee of the Whole meeting to be held in-person on Thursday, April 28, 2022 at 6:00 P.M. in the Council Chambers to address the Council and residents on the State of the City

CITY OF SALEM



In City Council, April 14, 2022

ORDERED: That the following license Applications be Granted.

TAG DAYS: SHS Boys Volleyball May 1 & 28, 2022
SHS Girls Soccer Sept. 17th & Oct. 15th, 2022

SEAWORMS: Joe Mendonca 22 Spring St. Peabody

In City Council April 14, 2022

ATTEST:

**ILENE SIMONS
CITY CLERK**



CHIEF OF POLICE
LUCAS J. MILLER

City of Salem, Massachusetts
Police Department Headquarters
95 Margin Street
Salem, Massachusetts 01970
(978) 744-2204

25 March 2022

Ms. Ilene Simons
City Clerk
Salem City Hall
93 Washington Street
Salem, Massachusetts 01970

Dear City Clerk Simons,

As you are aware, earlier this month the Salem Police Department acquired a community resource dog (CRD), "Derby". The CRD program is relatively new to the law enforcement profession and with Derby being new to the Department, I would like to take the opportunity to introduce Derby to members of the City Council at their next in-person meeting. In addition to the introduction, I will provide the Council with a brief overview of how the CRD program will be implemented in Salem.

I am looking forward to addressing the Council and introducing the newest member of the Department.

If you require any additional information on this request, please feel free to contact either myself or my administrative aide, Mr. Bob Mulligan, at (978) 744-0171 extension 50103 (bmulligan@salempd.net).

Sincerely,

Lucas J. Miller
Chief of Police

cc: Mayor Driscoll
Captain Burke
Officer Rondinelli



CITY OF SALEM PLANNING BOARD

2022 APR -1 AM 11: 02

CITY CLERK
SALEM, OREGON

Report of the Planning Board to City Council Re: Visibility at Intersections

April 1, 2022

At its meeting on March 31, 2022, the Planning Board discussed a proposed amendment to the Zoning Ordinance to amend Section 6.8 to increase the distance from an intersection wherein all structures must be 3 feet or shorter from 25 feet to 35 feet, which was referred from the March 15, 2022, joint public hearing with the City Council.

The Planning Board voted one (1) in favor (Tom Furey) and seven (Bill Griset, Helen Sides, Sarah Tarbet, Todd Waller, Carole Hamilton, Kirt Rieder, Zach Caunter) opposed to recommend that the City Council adopt the proposed amendment to the Zoning Ordinance, with the following comments:

- The amendment should conform with existing language in the Salem Code of Ordinances, Chapter 4 (particularly where political signs are concerned);
- The amendment should be compatible with Section 8.2.6.1. (Entrance Corridor Overlay District, Fences);
- The amendment should provide clarity on the line of measurement from where height is measured;
- The amendment should, if used, provide clarity on the definition of "intersection street lines" -
 - o Clarify that the distance is not measured from the centerline of the road;
 - o Consider if this is intended to be measured from the face of curb;
- The Planning Board would like clarification as to what obstructions Council seeks to manage with this ordinance.

If you have questions regarding this matter, please contact Tom Daniel, AICP, Director of Planning & Community Development, at 978-619-5685.

Sincerely,

William Griset
Chair

CC: Ilene Simons, City Clerk



CITY OF SALEM PLANNING BOARD

2022 APR -1 AM 11:02

CITY CLERK
SALEM, MASS

Report of the Planning Board to City Council Re: Urban Agriculture Amendment

April 1, 2022

At its meeting on March 31, 2022, the Planning Board discussed a proposed amendment to the Zoning Ordinance to address Urban Agriculture, including composting, beekeeping, keeping of domestic fowl, sale of products from urban farms, and more, and amend Section 10, Section 3.1, and Section 3.2.7 of the Zoning Ordinance. This amendment was referred to the Planning Board at the March 15, 2022, joint public hearing with the City Council.

The Planning Board voted eight (8) in favor (Bill Griset, Tom Furey, Helen Sides, Sarah Tarbet, Todd Waller, Carole Hamilton, Kirt Rieder, Zach Caunter) and zero (0) opposed to recommend that the City Council adopt the proposed amendment to the Zoning Ordinance, with the changes shown in the attached redline, provided by City's Health & Wellness Coordinator Kerry Murphy, MS, RDN.

If you have questions regarding this matter, please contact Tom Daniel, AICP, Director of Planning & Community Development, at 978-619-5685.

Sincerely,

A handwritten signature in black ink, appearing to read "William Griset".

William Griset
Chair

CC: Ilene Simons, City Clerk

In the year Two Thousand Twenty-one

An Ordinance to amend an ordinance relative to zoning and urban agriculture.

Be it ordained by the City Council of the City of Salem, as follows:

Section J. Section 10 of the Zoning Ordinance is hereby amended by deleting the definitions for *Agricultural use, nonexempt; Coop; Customary agricultural, horticultural and floricultural operations; Farm stand, nonexempt;* and *Urban agriculture* in their entirety and inserting the following new definitions:

“Agriculture, Urban (Urban Agriculture): An umbrella term that describes a range of accessory food and plant growing practices, either for personal use or for sale as an accessory use, that may include composting, the keeping of domestic fowl and honeybees, but does not include other livestock.

Arbor: An accessory Structure consisting of an open frame, freestanding or attached to another structure, with horizontal and/or vertical latticework often used as a support for climbing food or ornamental crops.

Coldframe: A Temporary Structure that is an accessory unheated outdoor Structure built close to the ground, no higher than thirty-six inches (36”) typically consisting of, but not limited to, a wooden or concrete frame and a top of glass or clear plastic, used for protecting seedlings and plants from cold weather.

Composting: A process of accelerated biodegradation and stabilization of organic material under controlled conditions yielding a product which can safely be used as fertilizer.

Coop: An enclosed shelter that houses domestic fowl.

Domestic fowl: A breed of bird specialized for meat production and/or egg laying and specifically excluding roosters.

Commercial Farm, Exempt (noun): Protected by G.L. c. 40A, § 3- meaning the use of land for the primary purpose of commercial agriculture, aquaculture, silviculture, horticulture, floriculture or viticulture, including those facilities for the sale of produce, wine and dairy products, provided that either during the months of June, July, August and September of each year or during the harvest season of the primary crop raised on land of the owner or lessee, 25 per cent of such products for sale, based on either gross sales dollars or volume, have been produced by the owner or lessee of the land on which the facility is located, or at least 25 per cent of such products for sale, based on either gross annual sales or annual volume, have been

produced by the owner or lessee of the land on which the facility is located and at least an additional 50 per cent of such products for sale, based upon either gross annual sales or annual volume, have been produced in Massachusetts on land other than that on which the facility is located, used for the primary purpose of commercial agriculture, aquaculture, silviculture, horticulture, floriculture or viticulture, whether by the owner or lessee of the land on which the facility is located or by another, except that all such activities shall be limited to parcels of 5 acres or more or to parcels 2 acres or more if the sale of products produced from the agriculture, aquaculture, silviculture, horticulture, floriculture or viticulture use on the parcel annually generates at least \$1,000 per acre based on gross sales dollars in area not zoned for agriculture, aquaculture, silviculture, horticulture, floriculture or viticulture. For the purposes of this definition, the term "agriculture" shall be as defined in section 1A of chapter 128, and the term horticulture shall include the growing and keeping of nursery stock and the sale thereof; provided, however, that the terms agriculture, aquaculture, floriculture and horticulture shall not include the growing, cultivation, distribution or dispensation of marijuana as defined in section 2 of chapter 369 of the acts of 2012, marijuana as defined in section 1 of chapter 94C or marijuana or marijuana as defined in section 1 of chapter 94G.

Roof Farm: Urban agriculture, on a roof of a principal or accessory structure with the intent to make personal use of or to sell whole, unprocessed produce, honey and/or eggs as an accessory use or, in the case of a commercial use, to be used in products sold on-site. All sales are subject to compliance with local, state and federal regulations.

Yard Farm: Urban agriculture on a residential Lot with intent to make personal use of or to sell whole, unprocessed produce, honey and/or eggs as an accessory use. All sales are subject to compliance with local, state and federal regulations including Board of Health soil testing requirements.

Farm Stand (Accessory): A Temporary Structure such as a table, stall or tent, operated by a sole vendor for the purpose of selling clean, whole, eggs, or honey, unprocessed produce and plants, all of which must be grown or produced on site.

Farm Structures: Includes, but are not limited to, sheds, compost bins, shade pavilions, trellises or other vertical supports for growing crops, and structures used to extend the growing season such as Greenhouses, Hoop houses, Coops, Coldframes and similar structures.

Garden, home/yard: An accessory use on a residential lot to grow plants and produce for beautification, recreation, and personal consumption. The garden may be outdoors, in an accessory structure or on the roof of a structure. Sales are prohibited.

Greenhouse: A Structure primarily constructed of a frame and transparent plastic material, in which temperature and humidity can be controlled for the cultivation or protection of plants or other agricultural products. All greenhouse structures are subject to setback and building code requirements.

Honeybee: A common domestic bee, *Apis mellifera* species.

Hoop house: An accessory Temporary Structure typically made of, but not limited to flexible PVC piping or other material covered with translucent plastic, constructed in a “half-round” or “hoop” shape, for the purposes of growing food or ornamental crops.

Raised Bed: method of cultivation in which soil is placed over a geotextile barrier, raised and ordinarily formed into three (3) to four (4) foot wide mounds. The soil may be enclosed by a frame generally made of untreated wood. Raised beds are not considered a Structure.

Section III. Section 3.1 Table of Principal and Accessory Use Regulations of the Zoning Ordinance is hereby amended by deleting the following uses: within B. EXEMPT AND INSTITUTIONAL USES: *Facilities for the sale of produce, and wine and dairy products, provided that during the months of June, July, August, and September of every year, or during the harvest season of the primary crop, the majority of such products for sale, based on either gross sales dollars or volume, have been produced by the owner of the land containing more than five acres in area on which the facility is located and Use of land for the primary purpose of agriculture, horticulture, floriculture, or viticulture on a parcel of more than five acres in area;* within , C. COMMERCIAL USES: *Agricultural use, nonexempt and Farm stand, nonexempt;* and within E ACCESSORY USES: *Urban agriculture and Customary agriculture, horticulture and floriculture operation ...* and inserting the following new uses within the Table:

| TABLE OF PRINCIPAL AND ACCESSORY USE REGULATIONS | | | | | | | | | | | |
|---------------------------------------------------------|-----------|-----------|-----------|-----------|-----------|-----------|-----------|-----------|----------|------------|-------------|
| PRINCIPAL USES | RC | R1 | R2 | R3 | B1 | B2 | B4 | B5 | I | BPD | NRCC |
| B. EXEMPT AND INSTITUTIONAL USES | | | | | | | | | | | |
| Commercial Farm, Exempt ¹ : | Y | Y | Y | Y | Y | Y | Y | Y | Y | Y | Y |
| E. ACCESSORY USES | RC | R1 | R2 | R3 | B1 | B2 | B4 | B5 | I | BPD | NRCC |
| Urban Agriculture (Subject to Section 3.2.7): | Y | Y | Y | Y | Y | Y | Y | Y | Y | Y | Y |

¹ A Commercial Farm, Exempt operated on a City-owned Lot or by the City on a Lot that is not owned by the City is exempt from the requirement that such use be conducted on parcels of 5 acres or more or parcels 2 acres or more if the sale of products produced from the agriculture, aquaculture, silviculture, horticulture, floriculture or viticulture use on the parcel annually generates at least \$1,000 per acre based on gross sales dollars in area not zoned for agriculture, aquaculture, silviculture, horticulture, floriculture or viticulture, so long as the products produced thereon are to be used for the benefit of the community and any revenue from any sales of those products are used for the sole purpose of sustaining the community farm.

| | | | | | | | | | | | |
|-------------------|---|---|---|---|---|---|---|---|---|---|---|
| Garden, home/yard | Y | Y | Y | Y | Y | Y | Y | Y | Y | Y | Y |
|-------------------|---|---|---|---|---|---|---|---|---|---|---|

Section III. Section 3.2 - Accessory Uses of the Zoning Ordinance is hereby amended by deleting Section 3.2.7 *Urban Agriculture* and Section 3.2.1 *Customary Agricultural, Horticultural and Floricultural Operations* in their entirety and replacing it with the following:

“3.2.7 Urban Agriculture

Urban Agriculture is allowed as an Accessory Use in all zoning districts, provided that no Urban Agriculture activity shall be conducted, nor Farm Structure erected, except in compliance herewith and with any other applicable laws, rules regulations including without limitation the building code and any requirements of the Salem Board of Health. .

1. Sale of Products

The on-site sale of agricultural products, including whole, unprocessed produce, honey or eggs, is allowed subject to the following provisions:

- a. Retail sale display areas shall not exceed fifty square feet.
- b. One Farm Stand is allowed per lot.
- c. No sales display, sign or Structure, including a Farm Stand, shall be located on a public sidewalk or street or block vehicle and/or pedestrian flow.
- d. Signage shall be limited to one (1) sign and not exceed six (6) square feet; signs shall not be illuminated or require electricity. No off-premises signs are allowed.
- e. All products sold on the Lot must be produced on-site. For purposes of this Ordinance, the term “produced on-site means” grown on the Lot or, in the case of domestic fowl or honey bees produced on the Lot by the animals kept thereon .
- f. Sales of products shall be permitted between the hours of 7:00 am and 6:00 pm., May 1 to October 31st. Sales shall not be permitted more than three days per week and no more than 25 total days per year.

2. Domestic Fowl

- a. Domestic fowl must be owned or rented by a resident or tenant of the location dwelling on the lot who shall be responsible for the care and control of the fowl.
- b. No roosters shall be kept under an Urban Agricultural use or any other use on lots in Salem.
- c. Dimensional Regulations
 - i. Maximum Height.
 - 1. Coop. Enclosed Coop space shall not exceed eight (8) feet in height.
 - 2. Run. Runs shall not exceed eight (8) feet in height.

- ii. Size
 1. Coop structures shall meet all building code requirements. Structures exceeding one hundred twenty (120) sq feet or eight (8) feet in height will require building permits and structures with electrical or plumbing shall require appropriate permits. Changes in the building code shall pre-empt this section.
 2. Coop. Coop space must allow a minimum of four (4) square feet per fowl and one (1) nest box per three (3) fowl.
 3. Run. Runs must allow a minimum of four (4) square feet per fowl.
- d. Setback Requirements
 - i. No fixed coop or run shall be located nearer than five (5) feet to any principal building, including the principal building on an abutting lot, and no coop or run shall be located nearer than five (5) feet to any side or rear lot line. Side lots in this instance refer to a projected line starting from the front lot line, terminating at the rear lot line parallel five (5) feet from the side lot line.
 - ii. Coops and/or runs are not permitted within 20 feet of a front lot line.
 - iii. Moveable coops (i.e. coops on wheels) and runs are not subject to setback requirements.
 - iv. Any lawfully existing domestic fowl-keeping use or structure in existence prior to the adoption of this Section shall be allowed to continue, as per the zoning code enforcement standards for other pre-existing nonconforming uses and structures. Any future alterations to applicable pre-existing uses or structures shall comply with this section or seek necessary approvals.
 - v. Coop structures shall not interfere with any existing public easements.
- e. Any domestic fowl-keeping use or structure in existence prior to the adoption of this Ordinance shall be allowed to continue, as per the zoning code enforcement standards of other pre-existing nonconforming uses and structures. Any future alterations to applicable pre-existing uses or structures shall seek necessary approvals.

3. Honeybees

- a. Honeybees must be owned, ~~rented~~, or hosted by a resident or tenant of the ~~dwelling location on the lot~~ who shall be responsible for the care and control of the Honeybees.
- b. A maximum of two (2) hives may be kept on a Lot with additional hives pending approval from the Salem Board of Health. Additional Board of Health regulations may further limit the number and/or manner of keeping of honeybees on lot.
- c. Dimensional Regulations
 - i. No Hive shall exceed five (5) feet in height and twenty (20) cubic feet in size on any Lot or roof.
- d. Setback Requirements

- i. Where there is a solid wall, fence or similar barrier between the subject property and abutting property, no setback from the property line is required. Where there is no wall, fence or similar barrier between subject property and abutting property, Hives shall be set back five (5) feet from the property line.
 - ii. No Hive shall be located closer than ten (10) feet from the lot line dividing the Lot from a sidewalk or street.
 - e. Hive Placement and Flyways.
 - i. For any ground level Hive that is within twenty (20) feet of the doors and/or windows of the principal building on an abutting Lot, either of the following conditions must exist:
 - ii. The Hive opening must face away from doors and/or windows; or
 - iii. A flyway of at least six (6) feet in height comprising of a lattice fence, dense hedge or similar barrier must be established in front of the opening of the Hive such that the honeybees fly upward and away from neighboring properties. The flyway shall be located within three (3) feet of the entrance to the Hive and shall extend at least two (2) feet in width on either side of the Hive opening.
 - f. Specific Rooftop Beekeeping Requirements.
 - i. Dimensional Regulations.
 - 1. No Hive shall exceed five (5) feet in height and twenty (20) cubic feet in size on any Lot or roof.
 - ii. Setback Requirements
 - 1. Hives shall be set back six (6) feet from the edge of the roof.
 - iii. Hive Placement and Flyways.
 - 1. For any roof level Hive that is within twenty (20) feet of the doors and/or windows of the principal building on an abutting Lot, either of the following conditions must exist:
 - a. The Hive opening must face away from doors and/or windows; or
 - b. A flyway of at least six (6) feet in height comprising of a lattice fence, dense hedge or similar barrier must be established in front of the opening of the Hive such that the honeybees upward and away from neighboring properties. The flyway shall be located within three (3) feet of the entrance to the Hive and shall extend at least two (2) feet in width on either side of the Hive opening.

4. Yard Farms

- a. Yard farms may be kept on residential properties only.
- b. Ownership, care and control of the farm shall be the responsibility of a resident of the dwelling on the lot.
- c. Land devoted to the Yard Farm shall be well-maintained and free from debris, noxious odor and excessively tall weeds and grass.

- d. Yard farms may include Raised Beds, Arbors, Greenhouses, Hoop Houses and Cold Frames as accessory structures subject to applicable setbacks and dimensional regulations.
- e. All accessory structures shall also be well-maintained in a safe condition.

5. Roof Farms

- a. Ownership, care and control of the roof farm shall be the responsibility of the owner or tenant of Lot.

6. Farm Structures

- a. Farm structures such as arbors, greenhouses, hoop houses and cold frames, shall be allowed as accessory structures subject to the following provisions:
 - i. Green houses are allowed within any rear or side yard up to but not closer than five (5) feet from the Lot line.
 - ii. Arbors, hoop houses and cold frames are allowed within any rear or side yard up to but not closer than one (1) foot from the Lot line.
 - iii. Farm Structures shall not exceed a maximum height of 15 feet and cannot be taller than the principal structure on the Lot; the covers shall be removed and stored when plants are not being cultivated or structure is not being used for an urban agricultural use
 - iv. Farm structures, when combined with other buildings on the property, shall not exceed the maximum lot coverage by all buildings listed in the Table of Dimensional Requirements.
 - v. Farm Structures shall not interfere with any existing public easements.

7. Composting

- a. Composting must be contained within an enclosed bin that does not have direct contact with flammable materials.
- b. Setback Requirements
 - i. Compost bins, structures and windrows shall be set back five (5) feet from all Lot lines.
 - ii. Compost bins, structures and windrows shall not be located in any portion of a yard area that abuts a Street.
- c. Accessory composting shall be used primarily to support onsite operations and shall comprise no more than five (5%) percent of the Lot area.”

Section IV. This Ordinance shall take effect as provided by City Charter.



FP-002A
(Rev. 1.2018)

The Commonwealth of Massachusetts
City/Town of Salem, MA

Application For License

Massachusetts General Law, Chapter 148 §13

New License Amended License

| |
|-----------------|
| GIS Coordinates |
| <u>42.50</u> |
| LAT. |
| <u>-70.93</u> |
| LONG. |
| License Number |

Application is hereby made in accordance with the provisions of Chapter 148 of the General Laws of Massachusetts for a license to store flammables, combustibles or explosives on land in buildings or structures herein described.

Location of Land: 342 Highland Avenue (Map 8, Lots 14 and 15)
Number, Street and Assessor's Map and Parcel ID

Attach a plot plan of the property indicating the location of property lines and all buildings or structures.

Owner of Land: William H. Goldberg Family, LLC

Address of Land Owner: 7 Rantoul Street, Suite 100B, Beverly, MA 01915

Use and Occupancy of Buildings and Structures: Retail Motor Fuel and Convenience Store

If this is an application for amendment of an existing license, indicate date of original license and any subsequent amendments

Attach a copy of the current license

Flammable and Combustible Liquids, Flammable Gases and Solids

Complete this section for the storage of flammable and combustible liquids, solids, and gases; see 527 CMR 1.00 Table 1.12.8.50; Attach additional pages if needed. All tanks and containers are considered full for the purposes of licensing and permitting.

| PRODUCT NAME | CLASS | MAXIMUM QUANTITY | UNITS gal., lbs, cubic feet | CONTAINER UST, AST, IBC, drums |
|-----------------|-------|------------------|-----------------------------------|--------------------------------------|
| <u>Gasoline</u> | | <u>30,000</u> | <u>Gal</u> | <u>UST</u> |
| <u>Diesel</u> | | <u>6,000</u> | <u>Gal</u> | <u>UST</u> |
| <u>Propane</u> | | <u>420</u> | <u>Lbs</u> | <u>20lb cyls</u> |
| | | | | |
| | | | | |

Total quantity of all flammable liquids to be stored: 30,000 gal

Total quantity of all combustible liquids to be stored: 6,000 gal

Total quantity of all flammable gases to be stored: 420 lbs

Total quantity of all flammable solids to be stored: n/a

LP-gas (Complete this section for the storage of LP-gas or propane)

Indicate the maximum quantity of LP-gas to be stored and the sizes and capacities of all storage containers. (See 527 CMR 1.00 Table 1.12.8.50)

❖ Maximum quantity (in gallons) of LP-gas to be stored in aboveground containers: 90 gal (420lb) propane

List sizes and capacities of all aboveground containers used for storage: 21ea 4.5gal/20lb cylinders

❖ Maximum quantity (in gallons) of LP-gas to be stored in underground containers: NONE UG

List sizes and capacities of all underground containers used for storage: n/a

Total aggregate quantity of all LP-gas to be stored: 90 gal (420lb) propane

Fireworks (Complete this section for the storage of fireworks) NONE - NO FIREWORKS

Indicate classes of fireworks to be stored and maximum quantity of each class. (See 527 CMR 1.00 Table 1.12.8.50)

❖ Maximum amount (in pounds) of Class 1.3G: _____ Type/class of magazine used for storage: _____

❖ Maximum amount (in pounds) of Class 1.4G: _____ Type/class of magazine used for storage: _____

❖ Maximum amount (in pounds) of Class 1.4: _____ Type/class of magazine used for storage: _____

Total aggregate quantity of all classes of fireworks to be stored: _____

Explosives (Complete this section for the storage of explosives) NONE - NO EXPLOSIVES

Indicate classes of explosive to be stored and maximum quantity of each class. (See 527 CMR 1.00 Table 1.12.8.50)

❖ Maximum amount (in pounds) of Class 1.1: _____ Number of magazines used for storage: _____

❖ Maximum amount (in pounds) of Class 1.2: _____ Number of magazines used for storage: _____

❖ Maximum amount (in pounds) of Class 1.3: _____ Number of magazines used for storage: _____

❖ Maximum amount (in pounds) of Class 1.4: _____ Number of magazines used for storage: _____

❖ Maximum amount (in pounds) of Class 1.5: _____ Number of magazines used for storage: _____

❖ Maximum amount (in pounds) of Class 1.6: _____ Number of magazines used for storage: _____

I, Anthony Guba, hereby attest that I am authorized to make this application. I acknowledge that the information contained herein is accurate and complete to the best of my knowledge and belief. I acknowledge that all materials stored pursuant to any license granted hereunder must be stored or kept in accordance with all applicable laws, codes, rules and regulations, including but not limited to Massachusetts Chapter 148, and the Massachusetts Fire Code (527 CMR 1.00). I further acknowledge that the storage of any material specified in any license granted hereunder may not exceed the maximum quantity specified by the license.

Signature  Date 10 March 2022 Name Anthony Guba, A.L. Prime Energy

Fire Department Use Only

I, Alan E. Dixon, Head of the Salem Fire Department endorse this application with my

Approval Disapproval

 _____
Signature of Head of the Fire Department Date

Recommendations: None

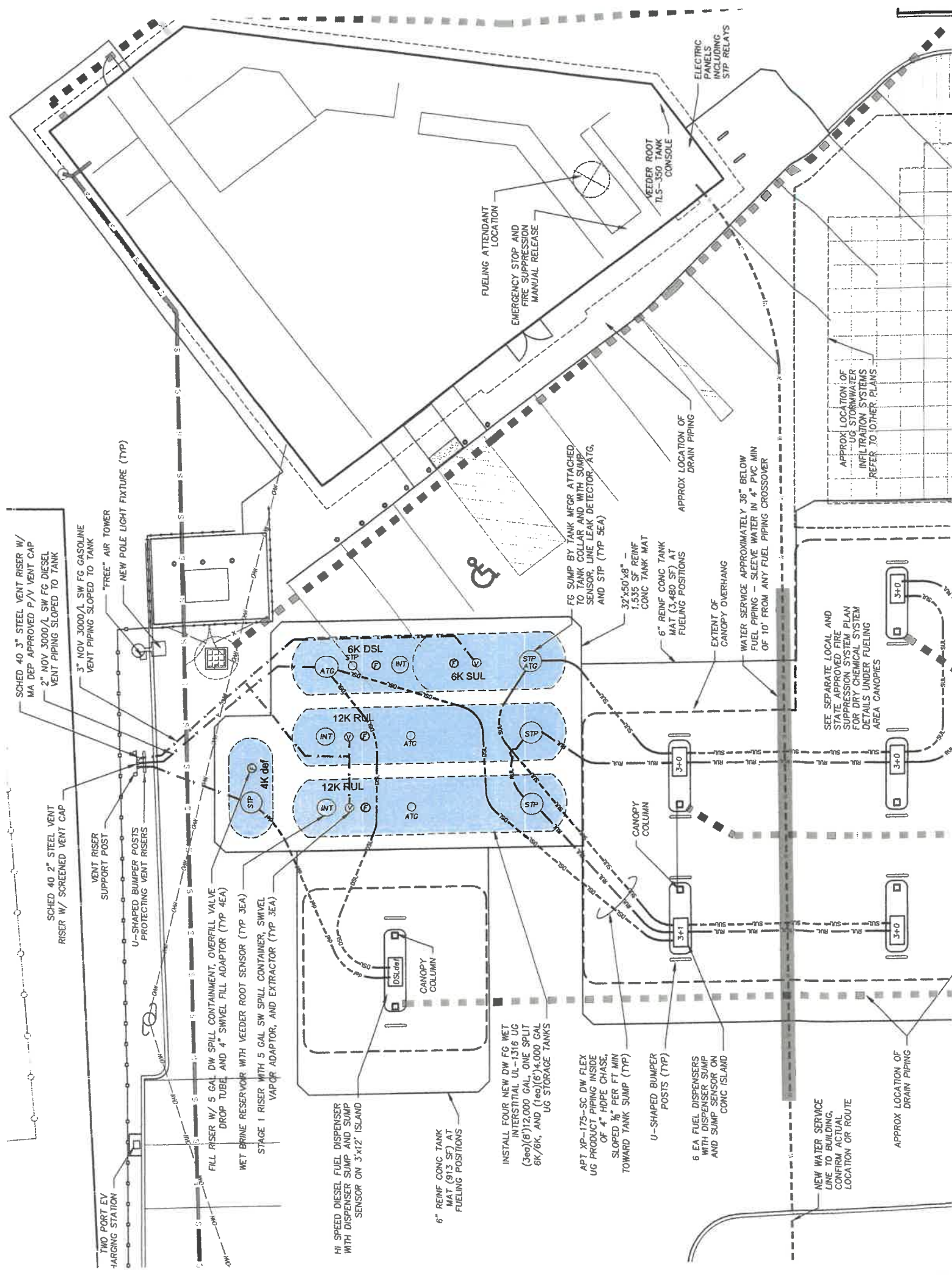

SCHED 40 3" STEEL RISER W/
MA DEP APPROVED P/V VENT CAP
2" NOV 3000/L SW FG DIESEL
VENT PIPING SLOPED TO TANK

SCHED 40 2" STEEL VENT
RISER W/ SCREENED VENT CAP
VENT RISER
SUPPORT POST
U-SHAPED BUMPER POSTS
PROTECTING VENT RISERS

3" NOV 3000/L SW FG GASOLINE
VENT PIPING SLOPED TO TANK
"FREE" AIR TOWER
NEW POLE LIGHT FIXTURE (TYP)

FILL RISER W/ 5 GAL DW SPILL CONTAINMENT, OVERFILL VALVE
DROP TUBE, AND 4" SWIVEL FILL ADAPTOR (TYP 4EA)
WET BRINE RESERVOIR WITH VEEDER ROOT SENSOR (TYP 3EA)
STAGE 1 RISER WITH 5 GAL SW SPILL CONTAINER, SWIVEL
VAPOUR ADAPTOR, AND EXTRACTOR (TYP 3EA)

HI SPEED DIESEL FUEL DISPENSER
WITH DISPENSER SUMP AND SENSOR
SENSOR ON 3'x12' ISLAND

6" REINF CONC TANK
MAT (91.5 SF) AT
FUELING POSITIONS

INSTALL FOUR NEW DW FG WET
INTERSTITIAL UL-1316 UG
(3ea)(6')/12,000 GAL, ONE SPLIT
6K/8K, AND (1ea)(6')/4,000 GAL
UG STORAGE TANKS

APT. YR-175-SC DW FLEX
UG PRODUCT PIPING INSIDE
OF 4" HDPE CHASE,
SLOPED 1/8" PER FT MIN
TOWARD TANK SUMP (TYP)

U-SHAPED BUMPER
POSTS (TYP)

6 EA FUEL DISPENSERS
WITH DISPENSER SUMP
AND SUMP SENSOR ON
CONC ISLAND

NEW WATER SERVICE
LINE TO BUILDING,
CONFIRM ACTUAL
LOCATION OR ROUTE

FUELING ATTENDANT
LOCATION
EMERGENCY STOP AND
FIRE SUPPRESSION
MANUAL RELEASE

VEEDER ROOT
TIL5-350 TANK
CONSOLE

ELECTRIC
PANELS
INCLUDING
STP RELAYS

FG SUMP BY TANK MFR ATTACHED
TO TANK COLLAR AND WITH SUMP
SENSOR, LINE LEAK DETECTOR, ATG,
AND STP (TYP 5EA)

32'x50'x8" -
1,535 SF REINF
CONC TANK MAT

6" REINF CONC TANK
MAT (3,480 SF) AT
FUELING POSITIONS

EXTENT OF
CANOPY OVERHANG

WATER SERVICE APPROXIMATELY 36" BELOW
FUEL PIPING - SLEEVE WATER IN 4" PVC MIN
OF 10' FROM ANY FUEL PIPING CROSSOVER

APPROX LOCATION OF
DRAIN PIPING

APPROX LOCATION OF
US STORMWATER
INFILTRATION SYSTEMS
REFER TO OTHER PLANS

SEE SEPARATE LOCAL AND
STATE APPROVED FIRE
SUPPRESSION SYSTEM PLAN
FOR DRY CHEMICAL SYSTEM
DETAILS UNDER FUELING
AREA CANOPIES

APPROX LOCATION OF
DRAIN PIPING

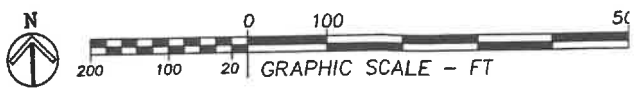
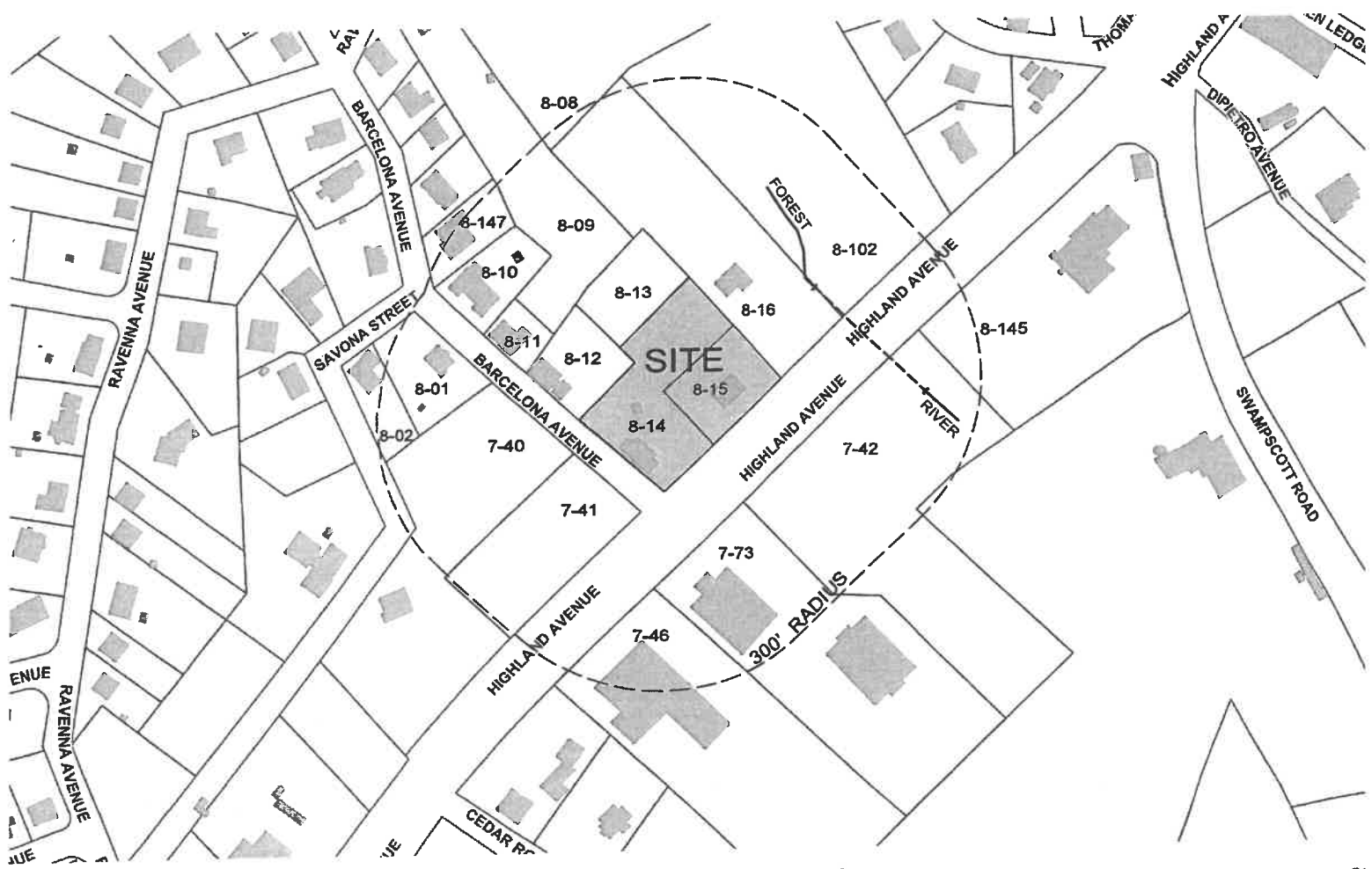

UNITY MAP



David R. Flewelling
Specialist 2 Construction
Comcast Cable Communications
9 Forbes Road, Suite 9B
Woburn, MA 01801
Cell – 617-279-7864
dave_flewelling@comcast.com

March 29, 2022

Ms. Maureen Fisher
Salem Assistant City Clerk
City Hall
93 Washington Street
Salem, MA 01970

RE: 36 Margin Street Salem
Grant of Location-Petition

Dear Ms. Fisher:

Enclosed please find materials supporting Comcast request for a grant of location from the Salem City Council. The work associated with the attached petition is for the purpose of installing a new conduit to provide the Comcast Service to number 36 Margin Street. For a more detailed description of the work located on High Street please refer to the attached construction plans.

I look forward to the opportunity to address this matter in further detail at the next Salem City Council Meeting. Should you have any questions or concerns, please feel free to contact me at (617) 279-7864.

Sincerely,

A handwritten signature in black ink, appearing to read "David R. Flewelling", written over a horizontal line.

David R. Flewelling
Comcast
Specialist 2, Construction

Enclosure (3)

ORDER FOR CONDUIT & POLE LOCATION

In the City Council for the City of Salem, Massachusetts.

ORDERED:

That permission be and hereby is granted to Comcast Cable Communications Management LCC., to lay and maintain underground conduits, manholes and poles, with the wires and cables to be placed therein, under and above the surface of the following public way or ways as requested in petition of said Company dated March 29,2022

High Street: Locating the existing Comcast Conduit in the sidewalk on High Street, that is servicing number 50 Margin Street. Excavating to place a 17"x 30" vault over the conduit. From the newly placed vault excavating across High Street 27'+/_ to place (1) 2" PVC Conduit to number 36 Margin Street. Substantially as shown on plan, filed with said petition.

Also that permission be and hereby is granted said Comcast to lay and maintain underground conduits, manholes, cables and wires in the above or intersecting public ways for the purpose of making connections with such poles and buildings as it may desire for distributing purposes.

The foregoing permission is subject to the following conditions:

1. The conduits and manholes shall be of such materials and construction and all work done in such manner as to be satisfactory to the City Council or to such officers as it may appoint to the supervision of the work.
2. Said Company shall indemnify and save the City harmless against all damages, costs and expense whatsoever to which the City may be subjected in consequence of the acts or neglect of said Company, its agents or servants, or in any manner arising from the rights and privileges granted it by the City.
3. In addition said Company shall, before a public way is disturbed for the laying of its wire or conduits, execute its bond in a penal sum of Fifty Thousand Dollars (\$50,000) (reference being had to the bond already on file with said City) conditioned for the faithful performance of its duties under this permit.
4. Said Company shall comply with the requirements of existing by-laws and such as may hereafter be adopted governing the construction and maintenance of conduits and wires, so far as the same are not inconsistent with the laws of the Commonwealth.

I hereby certify that the foregoing order was adopted at a meeting of the City Council for the City of Salem, Massachusetts, held on the _____ day of _____ 2022.

(over)

City Clerk

We hereby certify that on _____, 2022, at _____ o'clock _____ M., at Salem, Massachusetts a public hearing was held on the petition of the Comcast for permission to lay and maintain underground conduits, manholes and connections, with the wires and cables to be placed therein, described in the order herewith recorded, that we mailed at least seven days before said hearing a written notice the time and place of said hearing to each of the owners of real estate determined by the last preceding assessment for taxation along the ways parts of ways upon which the Company is permitted to construct the lines said Company under said order. And that thereupon said order was duly adopted.

Salem City Council; Salem, Massachusetts

CERTIFICATE

I hereby certify that the foregoing is a true copy of a location order, and certificate of hearing with the notice adopted by the City Council for the City of Salem, Massachusetts, on the _____ day of _____ 2022, recorded with the records of location orders of said City, Book _____, Page _____. This certified copy is made under the provision of Chapter 166 of General Laws and any additions thereto or amendments thereof.

Attest:

City Clerk

PETITION OF COMCAST FOR LOCACTION FOR CONDUITS, MANHOLES AND
POLES

To the City Council for the City of Salem, Massachusetts:

Respectfully represents Comcast Cable Communications Management LLC., a company incorporated for the distribution of broadband services, that it desires to construct a line for such broadband under the public way or ways hereinafter specified.

High Street: Locating the existing Comcast Conduit in the sidewalk on High Street, that is servicing number 50 Margin Street. Excavating to place a 17"x 30" vault over the conduit. From the newly placed vault excavating across High Street 27'+/- to place (1) 2" PVC Conduit to number 36 Margin Street. Substantially as shown on plan, filed with said petition.

Wherefore, your petition prays that, after due notice and hearing as provided by law, the City Council may by Order grant your petitioner permission to construct, and a location for, such a line of conduits, manholes and poles with the necessary wires and cables therein, said conduits manholes and poles to be located, substantially as shown on the plan made by Dewsnap Engineering Associates dated March 25, 2022 and filed here with, under the following public way or ways of said City of Salem.

Comcast

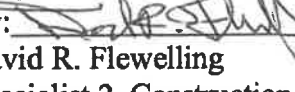
By: 
David R. Flewelling
Specialist 2, Construction

Dated this March 29, 2022

City of Salem, Massachusetts

Received and filed _____, 2022

PROPOSED COMCAST VAULT (17'X30') SHALL BE PLACED OVER EXISTING COMCAST CONDUIT IN CONCRETE SIDEWALK PANEL

CONCRETE SIDEWALK PANEL SHALL BE REPLACED IN KIND PER CITY OF SALEM ENGINEERING AND DPW STANDARDS.

PROPOSED COMCAST UNDERGROUND CONDUIT: 1-2" PVC, SCH. 40, LENGTH = 27' (PROPOSED COMCAST VAULT TO BUILDING AT 36 MARGIN ST.)

EXISTING CONCRETE PANEL TO BE REMOVED AND REPLACED TO CITY OF SALEM ENGINEERING AND DPW STANDARDS

- GENERAL LEGEND**
- SMH SEWER MANHOLE
 - WG WATER GATE
 - DMH DRAIN MANHOLE
 - GG GAS GATE
 - EMH ELECTRIC MANHOLE
 - LPT LIGHT POLE
 - CMH COMCAST MANHOLE
 - VCV VERT. GRANITE CURB
 - PK PARKING METER
 - SP SIGN POST
 - ADA HANDICAP
 - C — COMCAST UNDERGROUND CONDUIT
 - D — DRAIN LINE
 - G — GAS LINE
 - W — WATER LINE
 - S — SEWER LINE
 - E — UNDERGROUND ELECTRIC LINE
 - T — UNDERGROUND TELEPHONE
 - P — PROPOSED COMCAST UNDERGROUND CONDUIT(S)

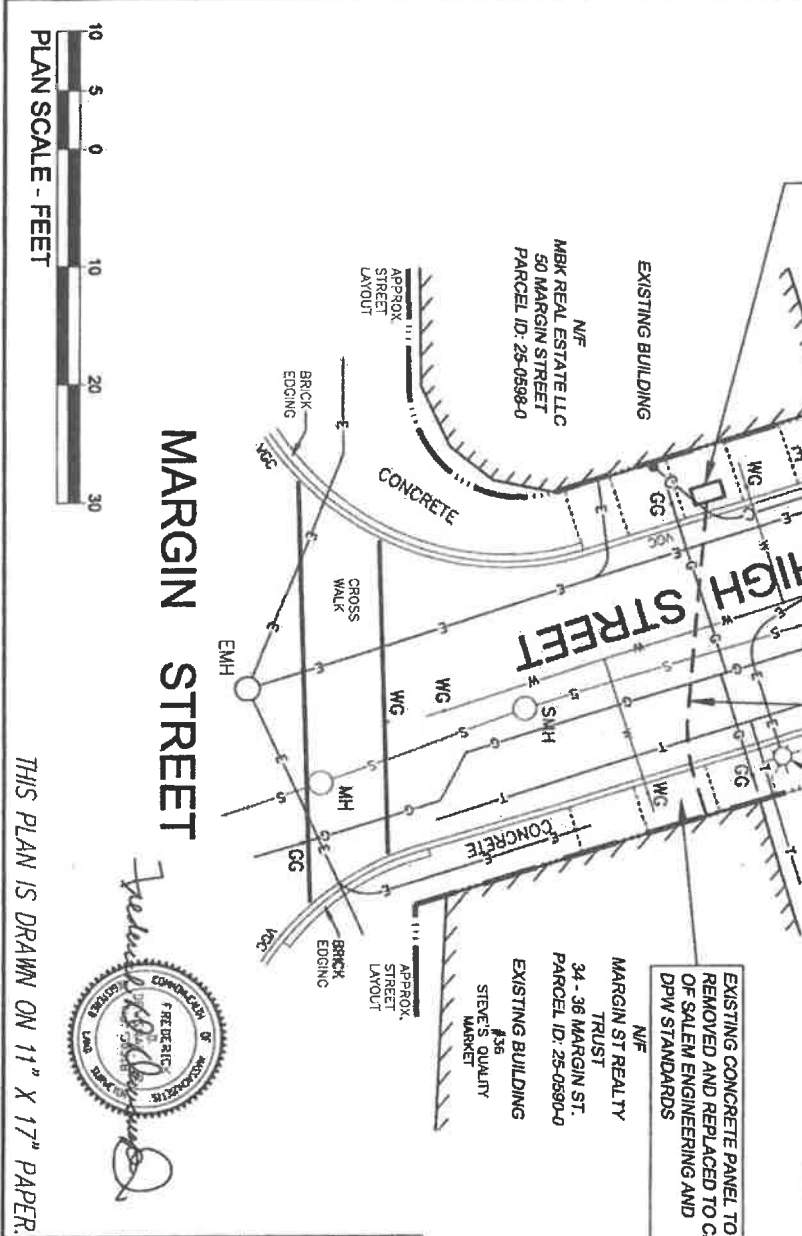

THIS PLAN IS DRAWN ON 11" X 17" PAPER.



| | |
|-------------------------------------|--------------------------------------------------------------------------------------------------|
| WARD 2, PRECINCT 2 | |
| PROPOSED COMCAST UNDERGROUND | |
| ESSEX COUNTY | |
| PLAN OF LAND | |
| IN | |
| SALEM, MA | |
| 36 MARGIN STREET | |
| Prepared for: | COMCAST 9 ROBESON ROAD, SUITE 88 WOBURN, MA 01801 |
| Prepared by: | DEMSNAP ENGINEERING ASSOC. LLP 175 LUDLOW AVENUE - SUITE 200, MA 01730 TEL: (781) 253-0585 |
| Date: | MARCH 25, 2022 |
| Checked by: | F.D.D. & P.A.D. |
| Drawn by: | P.A.D. |
| Field by: | P.A.D. & A.C.D. |
| Scale: | 1" = 10' |
| PROJECT LOCATION: | 36 MARGIN STREET |
| Sheet No. | 1 of 3 |

DETAIL NOTE:

1. The details depicted are for general reference only. The final product used shall be the responsibility of the general contractor and shall be of equal or greater material than that depicted and shall conform to the Engineering/DPW Standards for the state, city/town where the project is located.

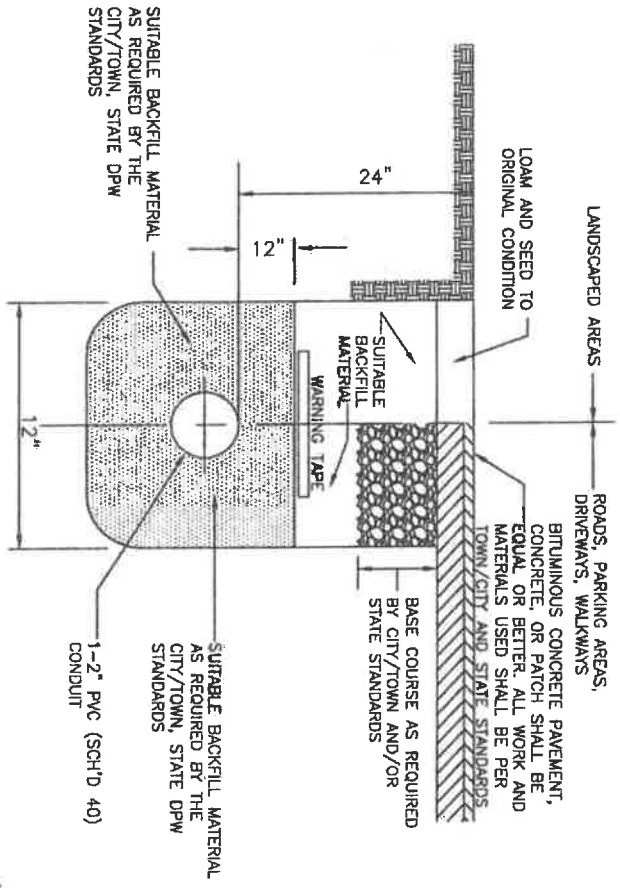

**GENERAL CATV TRENCH DETAIL
FOR 2" PVC, SCH. 40 CONDUIT**
NOT TO SCALE

John J. DeWinn

THIS PLAN IS DRAWN ON 11" X 17" PAPER.

NOTES:

1. These plans were prepared from record plan data on file at the City of Salem, Registry of Deeds and various utility companies.
2. The locations of underground utilities shown are based on above ground structures and record drawings, if any, provided to the Surveyor. The locations of underground utilities/structures may vary from location hereon and are not warranted to be accurate and/or correct. Additional buried utilities/structures may be encountered. No excavations were performed during the progress of this survey to locate buried utilities/structures.
3. Prior to any construction the Contractor shall notify DIG-SAFE at least 72 hours in advance at 811 (National Call Number) for verification of utilities and for field locations.
4. It is the responsibility of the Utility Contractor installing the Comcast underground conduit to notify those utility companies not associated with the DIG-SAFE system to verify the locations of their respective utilities. Also, the installing contractor shall be responsible for repairing or replacing any traffic signal loops damaged during the installation of the new Comcast underground conduit.
5. All work to be performed is the installation of a Comcast underground conduit and 1"x30" vault.
6. All work shall conform to the approving authorities Engineering and DPW Standards.
7. Prior to the start of any construction, the Utility Contractor shall confirm the number, vaults, the number of conduits and the size of the conduit(s) for this project with the Comcast project Coordinator.
8. Upon completion of the trench work for the day, the contractor shall backfill, compact and pave the trench and the work area shall be broom swept clean. In grassed areas the trench shall be loamed and seeded and hay mulch spread to keep the area stabilized until the grass has taken hold.
9. Street/property lines are not the result of a boundary survey and are considered to be approximate.

CONSTRUCTION NOTES:

1. Following the Dig-Safe "mark out" and field verification of the existing underground utilities, the Proposed 4"x4" Manhole shall be adjusted in the field by the utility contractor to avoid being located over any existing utilities.

| | |
|-------------------------------------|-------------------------------------------------------------------------------------------------|
| WARD 2, PRECINCT 2 | |
| PROPOSED COMCAST UNDERGROUND | |
| ESSEX COUNTY | |
| PLAN OF LAND | |
| IN | |
| SALEM, MA | |
| Prepared By: | COMCAST 9 FOREST ROAD, SUITE 88 WOBURN, MA 01801 |
| Prepared By: | DEWISMAP ENGINEERING ASSOC. LLP 178 Union Avenue, Salem, MA 01905 781-567-7813 / 233-0595 |
| Date: | MARCH 25, 2022 |
| Checked By: | F.O.D. & P.A.D. |
| Drawn By: | P.A.D. |
| Field By: | P.A.D. & A.C.D. |
| Scale: | Not To Scale |
| PROJECT LOCATION: | 36 MARGIN STREET |
| Sheet No. | 2 of 3 |

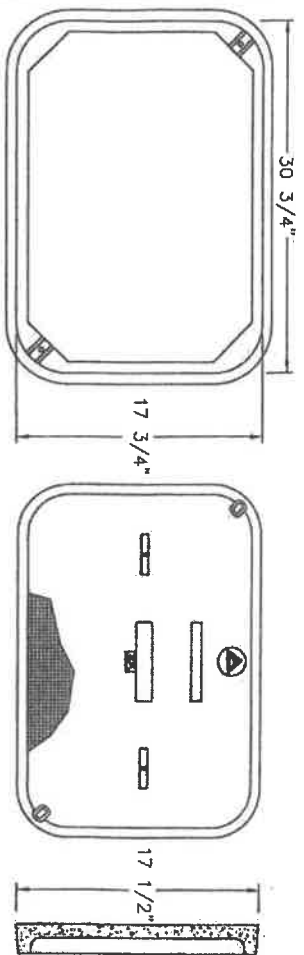

PLAN VIEW

APPROX. WT. = 190 LBS.

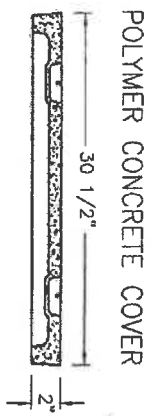

POLYMER CONCRETE COVER

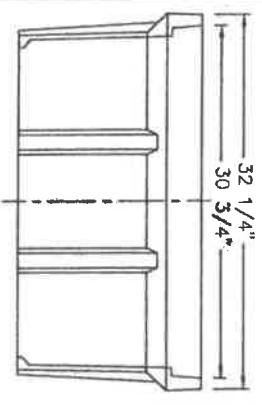

SIDE VIEW

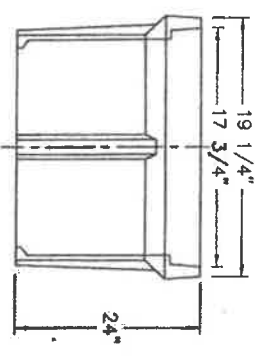

END VIEW

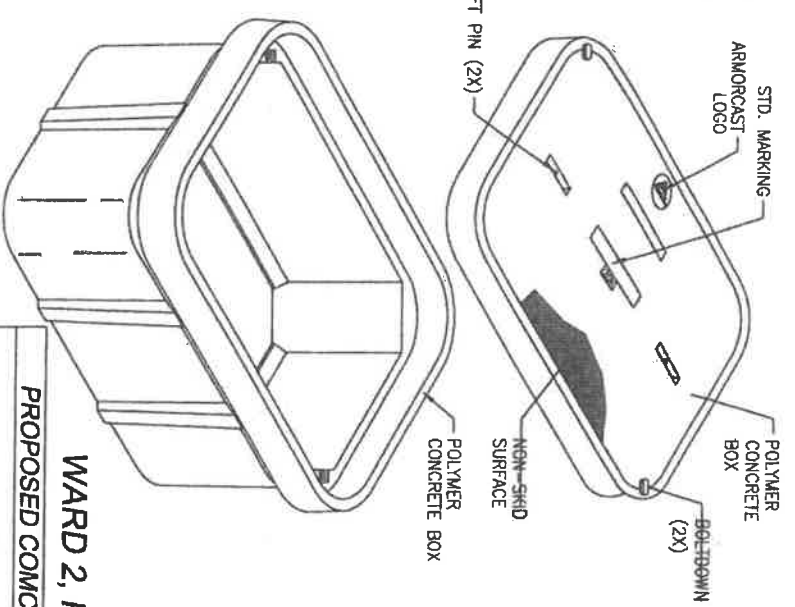

OPEN BASE

VAULT NOTES:

1. VAULTS SHALL BE AS MANUFACTURED BY ARMORCAST PRODUCTS COMPANY, CHASTWORTH, CA, 17" X 30" X 24" DEEP, TIER 22, 20K LOAD RATED, MODEL #A6001640HDAPCY24

ARMORCAST 17" X 30" VAULT DETAIL

NOT TO SCALE

THIS PLAN IS DRAWN ON 11" X 17" PAPER.



| | |
|----------------------------------------------------------------------------------------------------------------------------------------------------------------------------|----------------------------------------------------------------------------------------------------------------------------------|
| <p>WARD 2, PRECINCT 2</p> <p>PROPOSED COMCAST UNDERGROUND</p> <p>ESSEX COUNTY</p> <p>PLAN OF LAND</p> <p>IN</p> <p>SALEM, MA</p> | |
| <p>Prepared for:</p> <p>COMCAST</p> <p>9 ROBESON ROAD, SUITE 98</p> <p>WOBURN, MA 01807</p> | <p>Prepared By:</p> <p>DEWSNAP ENGINEERING ASSOC. LLP</p> <p>178 Lincoln Avenue - Salem, MA 01970</p> <p>Tel: (781) 239-0595</p> |
| <p>Date:</p> <p>MARCH 26, 2022</p> | <p>Scale:</p> <p>Not To Scale</p> |
| <p>Checked By:</p> <p>F.D.D. & P.A.D.</p> | <p>PROJECT LOCATION:</p> <p>36 MARGIN STREET</p> |
| <p>Drawn By:</p> <p>P.A.D.</p> | |
| <p>Field By:</p> <p>P.A.D. & A.C.O.</p> | |
| <p>Sheet No. 3 of 3</p> | |

National Grid Contact
Dana Wolkiewicz, Senior Supervisor Gas Construction
Dana.Wolkiewicz@nationalgrid.com
781-697-4631

Petition of:

National Grid
44 River St,
Beverly, MA,
01915

For the request to reconstruct our gas pressure regulator station and add a SCADA (Supervisory Control and Data Acquisition) System, with an electric service conduit in the public right of way. The installation is located in the shoulder of the roadway on **Appleton St**, adjacent to #162 **North St** and the intersection of **Appleton St & Orne St**.

TO: Lowell City Clerks Office.

Respectfully represents the NATIONAL GRID of 44 River St, Beverly, Massachusetts, that it desires to replace our existing gas pressure regulator station in the shoulder of the roadway on *Appleton St* at the intersection of *Appleton St* and *Orne St*. The proposed installation will replace the existing regulator station at the intersection of *Liberty Hill Ave* and *Appleton St* with a new station meeting National Grid's latest safety standards. This installation includes a new SCADA system, with an electric service conduit, and the necessary sustaining and protecting fixtures, under and across the public way hereinafter named.

Wherefore it prays that after due notice and hearing as provided by law, it be granted permission to excavate the public right of way to run and maintain a gas pressure regulator station, together with such sustaining and protecting fixtures as it may find necessary for the safe running operation of our underground gas structure and SCADA box, said gas pressure regulator station to be located substantially in accordance with the attached plan named – "4" Regulator Station Replacement 100 PSIG to 60 PSIG Liberty Hill Ave @ Appleton St."

NATIONAL GRID

Dana Wolkiewicz

BY _____
Sr Supervisor Gas

April 8, 2022

ORDERED:

Notice having been given and public hearing held, as provided by law, that National Grid be and it is hereby granted permission to excavate the public right of way to install the new station as shown in the plan named "4" Regulator Station Replacement 100 PSIG to 60 PSIG Liberty Hill Ave @ Appleton St," under and across the public way hereinafter named as said Company may deem necessary, in public way or ways hereinafter referred to, as requested in petition with the said COMPANY dated, April 8, 2022.

Said gas pressure regulator station shall be located substantially in accordance with the attached plan named - "4" Regulator Station Replacement 100 PSIG to 60 PSIG Liberty Hill Ave @ Appleton St."

The following are public ways along which the gas pressure regulator station above referred to may be installed: the shoulder of the roadway on Appleton St on City Property, Salem, Ma.

I hereby certify that the foregoing order was adopted at a meeting of the
....., held on the day of.....,20.....
....., 20.....

Received and entered in the records of location orders of the City of Salem, Ma.

Book.....Page.....

Attest:

.....hereby certify that on20....., at o'clock,..... PM
At....., a public hearing was held on the petition of
NATIONAL GRID for permission to install gas pressure regulator station as described in the
order herewith recorded, and that I mailed at least seven days before said hearing a written notice
of the time and hearing to each of the owners of real estate (as determined by the last preceding
assessment for taxation) along the ways or parts of ways upon which the Company is permitted
to install gas pressure regulator station under said order. And that thereupon said order was duly
adopted.

.....
.....
.....

nationalGrid

April 8, 2022

Salem City Clerks Office
93 Washington St,
Salem, MA 01970

To whom it may concern:

Enclosed please find a petition of National Grid covering the installation of a gas pressure regulator station.

If you have any questions regarding this permit please contact:

Dana Wolkiewicz,
44 River St,
Beverly, MA, 01925

Dana.Wolkiewicz@nationalgrid.com
Phone: 781-697-4631

If this petition meets with your approval, please return an executed copy to:

National Grid Contact:

Dana Wolkiewicz,
44 River St,
Beverly, MA, 01925

Dana.Wolkiewicz@nationalgrid.com
Phone: 781-697-4631

Very truly yours,

Dana Wolkiewicz
Sr Supervisor Gas Construction

nationalgrid

4" REGULATOR STATION REPLACEMENT
100 PSIG TO 60 PSIG
LIBERTY HILL AVE @ APPLETON ST,
SALEM, MA
W.O. NO.: 90000217367
STATION 589



LOCATION MAP
 LOCATION: SALEM, MA
 SCALE: 1:500

| SHEET | NUMBER | TITLE |
|-------|--------------------------|----------------------|
| 1 | SR-SAL-90000217367 G-001 | COVER - LOCATION MAP |
| 2 | SR-SAL-90000217367 G-002 | CONSTRUCTION NOTES |
| 3 | SR-SAL-90000217367 G-003 | CONSTRUCTION NOTES |
| 4 | SR-SAL-90000217367 C-001 | EXISTING CONDITIONS |
| 5 | SR-SAL-90000217367 C-002 | EXISTING CONDITIONS |
| 6 | SR-SAL-90000217367 C-003 | EXISTING CONDITIONS |
| 7 | SR-SAL-90000217367 C-004 | PROPOSED CONDITIONS |
| 8 | SR-SAL-90000217367 C-005 | TR-S&M DETAILS |
| 9 | SR-SAL-90000217367 C-006 | INLET TR-S&M DETAILS |
| 10 | SR-SAL-90000217367 C-007 | ABANDONMENT |
| 11 | SR-SAL-90000217367 C-008 | ABANDONMENT |
| 12 | SR-SAL-90000217367 M-001 | DETAILS |
| 13 | SR-SAL-90000217367 M-002 | DETAILS |
| 14 | SR-SAL-90000217367 H-001 | BILL OF MATERIALS |

| NO. | DESCRIPTION | DATE | BY | CHKD | APP'D | REV | DATE | BY | CHKD | APP'D |
|-----|--------------|------|----|------|-------|-----|------|----|------|-------|
| 1 | DESIGN | | | | | | | | | |
| 2 | CONSTRUCTION | | | | | | | | | |
| 3 | AS-BUILT | | | | | | | | | |
| 4 | REVISIONS | | | | | | | | | |

COVER - LOCATION MAP

LIBERTY HILL AVE @ APPLETON ST
 LIBERTY HILL AVE & APPLETON ST
 SALEM, MA

PROJECT NO. SR-SAL-90000217367 G-001

SHEET NO. 01

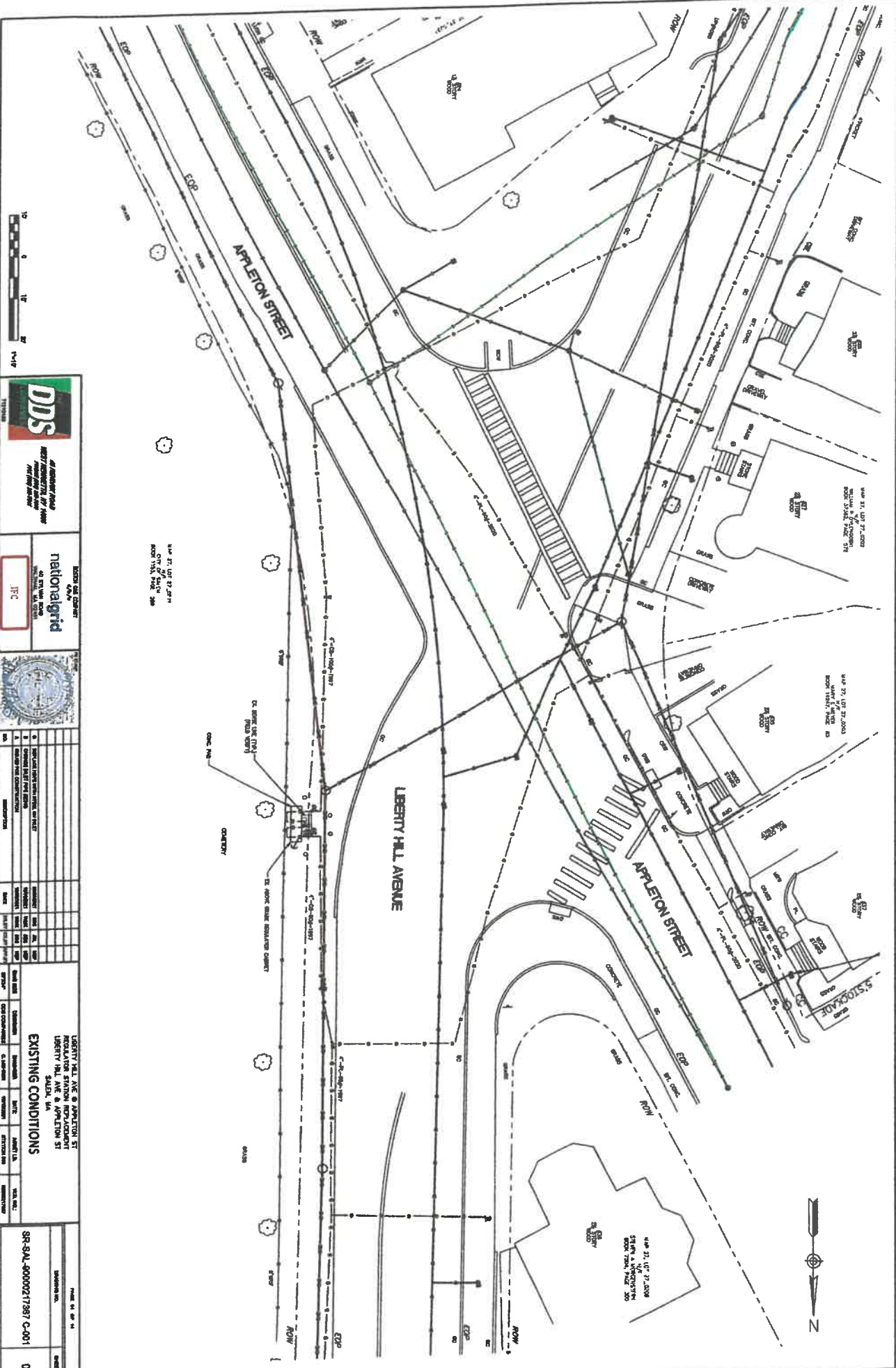

DESIGN AND CONSTRUCTION
BY
nationalgrid
400 WEST MAIN STREET
SAUCK, VA 22656



| NO. | DESCRIPTION | DATE | BY | CHECKED | DATE | BY | REVISION |
|-----|-------------------------|------|----|---------|------|----|----------|
| 1 | ISSUED FOR PERMIT | | | | | | |
| 2 | ISSUED FOR CONSTRUCTION | | | | | | |

| NO. | DESCRIPTION | DATE | BY | CHECKED | DATE | BY | REVISION |
|-----|-------------------------|------|----|---------|------|----|----------|
| 1 | ISSUED FOR PERMIT | | | | | | |
| 2 | ISSUED FOR CONSTRUCTION | | | | | | |

SR-SAL-0000217367-C-001

DATE: 04/24/14

PROJECT NO. 04

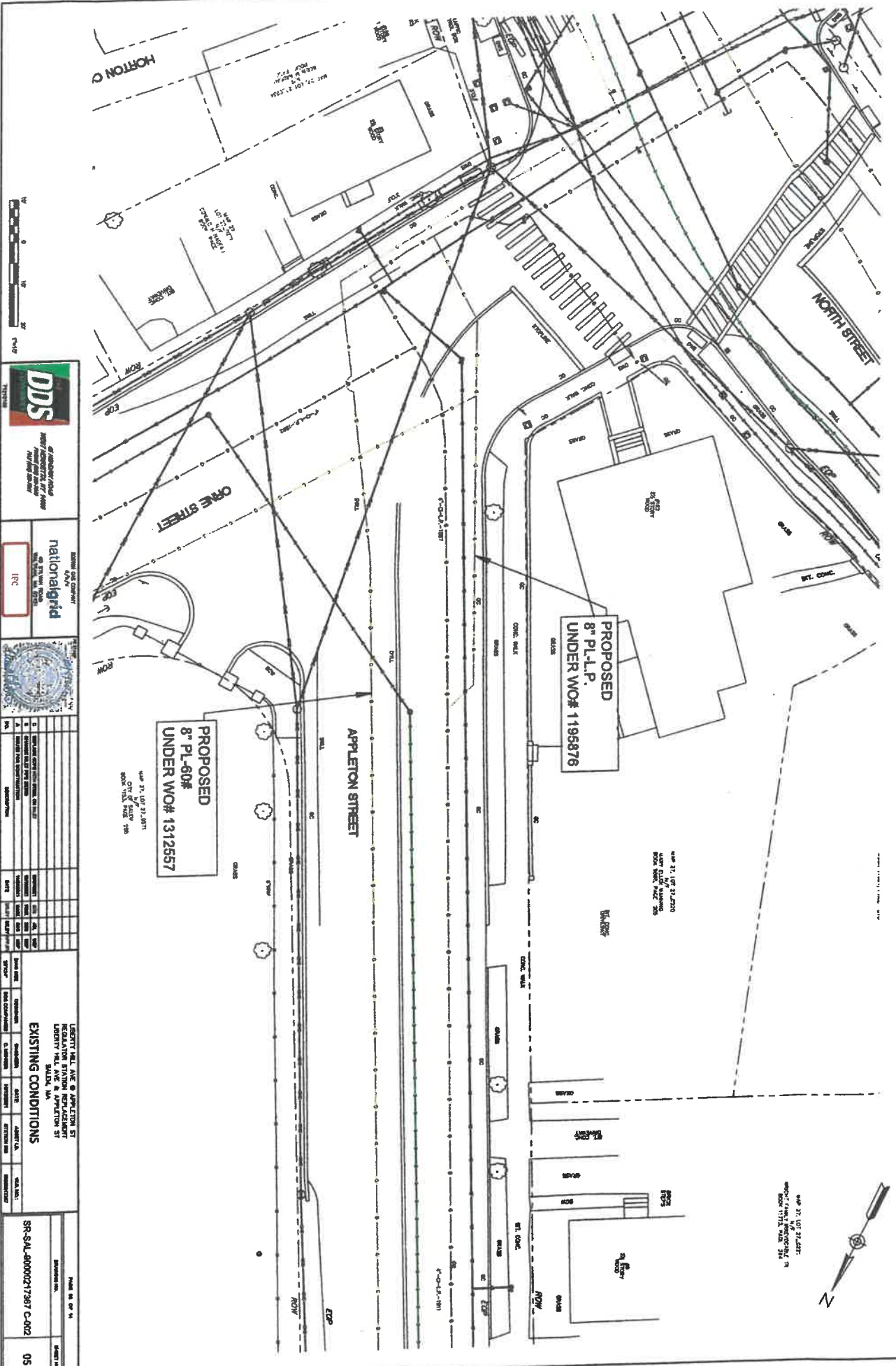

nationalgrid
AECOM



| NO. | DESCRIPTION | DATE | BY | CHECKED | DATE | BY | SCALE | STATUS |
|-----|-------------------------------------|------------|----|---------|------------|----|----------|-------------------|
| 1 | DESIGN DEVELOPMENT SERVICES ON SITE | 08/20/2018 | JL | MS | 08/20/2018 | JL | AS SHOWN | ISSUED FOR PERMIT |
| 2 | REVISIONS | | | | | | | |
| 3 | REVISIONS | | | | | | | |
| 4 | REVISIONS | | | | | | | |
| 5 | REVISIONS | | | | | | | |
| 6 | REVISIONS | | | | | | | |
| 7 | REVISIONS | | | | | | | |
| 8 | REVISIONS | | | | | | | |
| 9 | REVISIONS | | | | | | | |
| 10 | REVISIONS | | | | | | | |

LIBERTY HILL, AVE & APPLETON ST
REGULATIVE DIVISION REPLACEMENT
LIBERTY HILL, AVE & APPLETON ST
EXISTING CONDITIONS

SR-SAL-00000217267 C-002
05

NOTE:
1. EXISTING CONDITIONS FLOW DIAGRAM

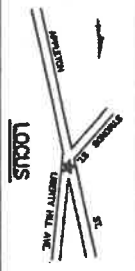
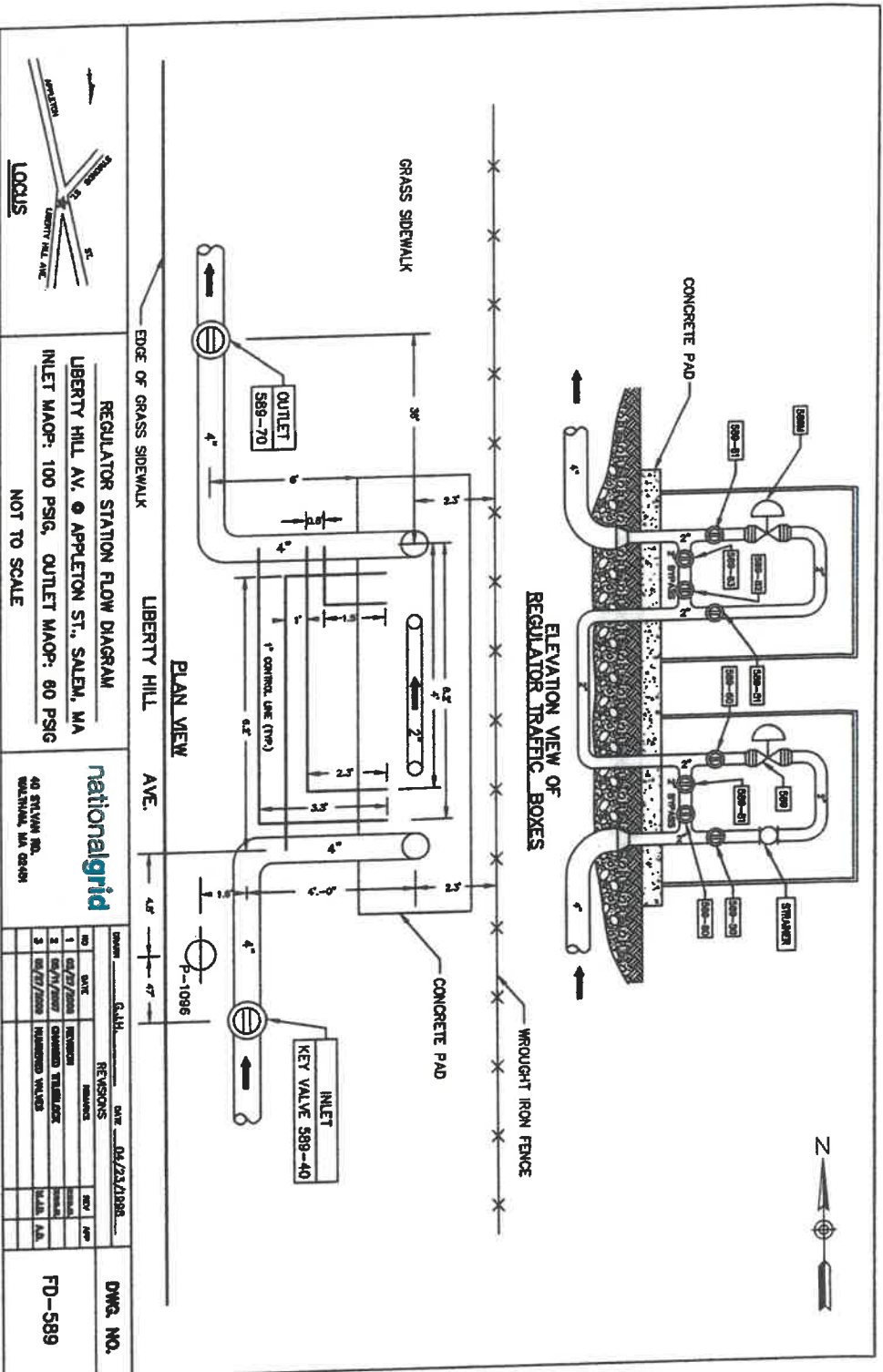

REGULATOR STATION FLOW DIAGRAM
LIBERTY HILL AV. @ APPLETON ST., SALEM, MA
INLET MAOP: 100 PSIG, OUTLET MAOP: 80 PSIG
NOT TO SCALE

nationalgrid
40 STYMAN RD.
METHUEN, MA 01844

| NO. | DATE | REVISIONS | BY | APP. |
|-----|------------|--------------------|----|------|
| 1 | 04/27/2008 | REVISION | | |
| 2 | 05/11/2007 | CHANGED TITLEBLOCK | | |
| 3 | 05/07/2008 | REMOVED VALVES | | |

DWG. NO.
FD-589



nationalgrid
40 STYMAN RD.
METHUEN, MA 01844
IFC



| NO. | DATE | REVISIONS | BY | APP. |
|-----|------------|--------------------|----|------|
| 1 | 04/27/2008 | REVISION | | |
| 2 | 05/11/2007 | CHANGED TITLEBLOCK | | |
| 3 | 05/07/2008 | REMOVED VALVES | | |

LIBERTY HILL AV. @ APPLETON ST.
REGULATOR STATION REVISIONS
LIBERTY HILL AV. & APPLETON ST.
SALEM, MA

EXISTING CONDITIONS

NOTE:
 1. ALL CURBING, PAVEMENT, SIDEWALKS, LAWN AREAS, STRIPING, DRIVEWAYS, TRAFFIC SIGNALS, LOOPS, FENCES, ETC. MUST BE RESTORED IN KIND AND/OR TO MUNICIPAL STANDARDS.



nationalgrid
 AEC



| NO. | DESCRIPTION | DATE | BY | CHKD. | APP'D. |
|-----|--------------|------|----|-------|--------|
| 1 | DESIGN | | | | |
| 2 | CHECK | | | | |
| 3 | CONSTRUCTION | | | | |
| 4 | AS-BUILT | | | | |

LIBERTY TALK, ONE S. BERTON ST.
 REGULATORY SYSTEM DEPARTMENT
 RALEIGH, VA

PROPOSED CONDITIONS
 SR-SAL-0000217287 C-004
 07

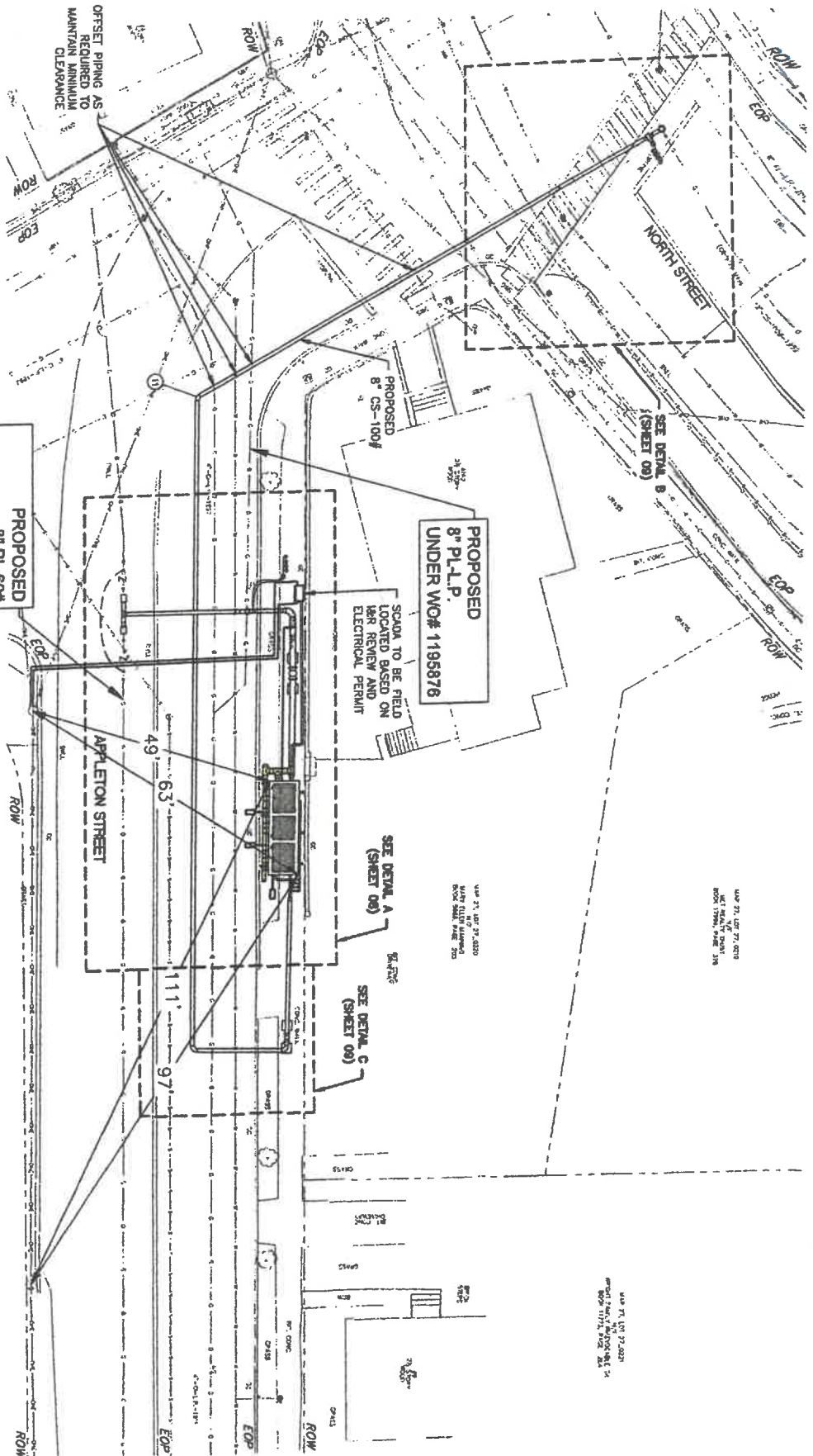

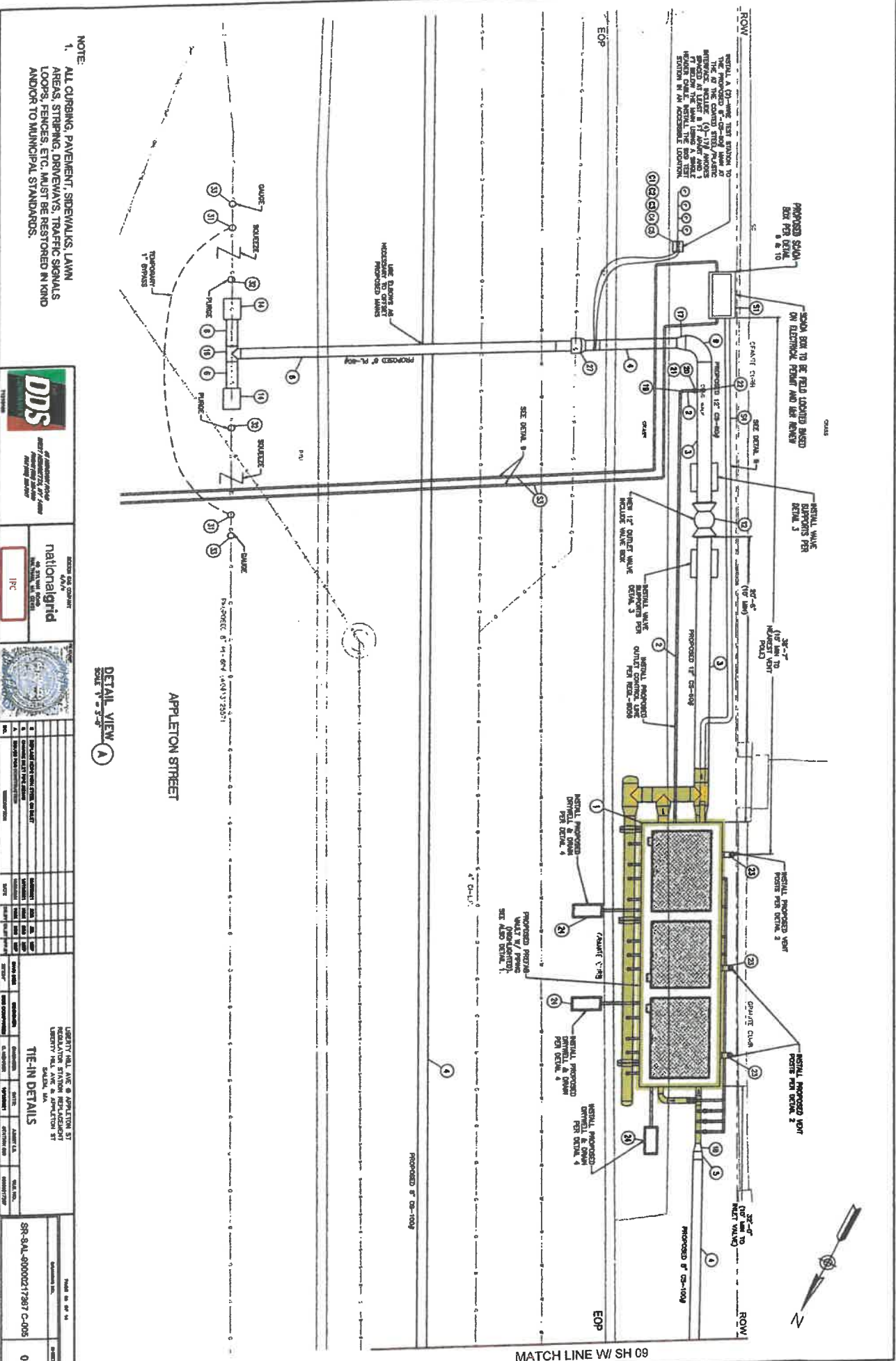

NOTE:
 1. ALL CURBING, PAVEMENT, SIDEWALKS, LAWN AREAS, STRIPING, DRIVEWAYS, TRAFFIC SIGNALS LOOPS, FENCES, ETC. MUST BE RESTORED IN KIND AND/OR TO MUNICIPAL STANDARDS.

DETAIL VIEW A



DESIGN AND CONSTRUCTION
 nationalgrid
 1100 N. 17th Street
 IFC



| NO. | DESCRIPTION | DATE | BY | CHKD. | APP'D. |
|-----|------------------------------|------|----|-------|--------|
| 1 | DESIGN DEVELOPMENT SOLUTIONS | | | | |
| 2 | DESIGN DEVELOPMENT SOLUTIONS | | | | |
| 3 | DESIGN DEVELOPMENT SOLUTIONS | | | | |
| 4 | DESIGN DEVELOPMENT SOLUTIONS | | | | |
| 5 | DESIGN DEVELOPMENT SOLUTIONS | | | | |
| 6 | DESIGN DEVELOPMENT SOLUTIONS | | | | |
| 7 | DESIGN DEVELOPMENT SOLUTIONS | | | | |
| 8 | DESIGN DEVELOPMENT SOLUTIONS | | | | |
| 9 | DESIGN DEVELOPMENT SOLUTIONS | | | | |
| 10 | DESIGN DEVELOPMENT SOLUTIONS | | | | |
| 11 | DESIGN DEVELOPMENT SOLUTIONS | | | | |
| 12 | DESIGN DEVELOPMENT SOLUTIONS | | | | |
| 13 | DESIGN DEVELOPMENT SOLUTIONS | | | | |
| 14 | DESIGN DEVELOPMENT SOLUTIONS | | | | |
| 15 | DESIGN DEVELOPMENT SOLUTIONS | | | | |
| 16 | DESIGN DEVELOPMENT SOLUTIONS | | | | |
| 17 | DESIGN DEVELOPMENT SOLUTIONS | | | | |
| 18 | DESIGN DEVELOPMENT SOLUTIONS | | | | |
| 19 | DESIGN DEVELOPMENT SOLUTIONS | | | | |
| 20 | DESIGN DEVELOPMENT SOLUTIONS | | | | |
| 21 | DESIGN DEVELOPMENT SOLUTIONS | | | | |
| 22 | DESIGN DEVELOPMENT SOLUTIONS | | | | |
| 23 | DESIGN DEVELOPMENT SOLUTIONS | | | | |
| 24 | DESIGN DEVELOPMENT SOLUTIONS | | | | |
| 25 | DESIGN DEVELOPMENT SOLUTIONS | | | | |
| 26 | DESIGN DEVELOPMENT SOLUTIONS | | | | |
| 27 | DESIGN DEVELOPMENT SOLUTIONS | | | | |
| 28 | DESIGN DEVELOPMENT SOLUTIONS | | | | |
| 29 | DESIGN DEVELOPMENT SOLUTIONS | | | | |
| 30 | DESIGN DEVELOPMENT SOLUTIONS | | | | |
| 31 | DESIGN DEVELOPMENT SOLUTIONS | | | | |
| 32 | DESIGN DEVELOPMENT SOLUTIONS | | | | |
| 33 | DESIGN DEVELOPMENT SOLUTIONS | | | | |
| 34 | DESIGN DEVELOPMENT SOLUTIONS | | | | |
| 35 | DESIGN DEVELOPMENT SOLUTIONS | | | | |
| 36 | DESIGN DEVELOPMENT SOLUTIONS | | | | |
| 37 | DESIGN DEVELOPMENT SOLUTIONS | | | | |
| 38 | DESIGN DEVELOPMENT SOLUTIONS | | | | |
| 39 | DESIGN DEVELOPMENT SOLUTIONS | | | | |
| 40 | DESIGN DEVELOPMENT SOLUTIONS | | | | |
| 41 | DESIGN DEVELOPMENT SOLUTIONS | | | | |
| 42 | DESIGN DEVELOPMENT SOLUTIONS | | | | |
| 43 | DESIGN DEVELOPMENT SOLUTIONS | | | | |
| 44 | DESIGN DEVELOPMENT SOLUTIONS | | | | |
| 45 | DESIGN DEVELOPMENT SOLUTIONS | | | | |
| 46 | DESIGN DEVELOPMENT SOLUTIONS | | | | |
| 47 | DESIGN DEVELOPMENT SOLUTIONS | | | | |
| 48 | DESIGN DEVELOPMENT SOLUTIONS | | | | |
| 49 | DESIGN DEVELOPMENT SOLUTIONS | | | | |
| 50 | DESIGN DEVELOPMENT SOLUTIONS | | | | |

LIBERTY HALL, INC. & APPLETON ST
 LIBERTY HALL, INC. & APPLETON ST
 LIBERTY HALL, INC. & APPLETON ST
 SADDEN, VA

TIE-IN DETAILS

SR-5AL-90000217887 C-005

08

MATCH LINE W/ SH 09

NOTE:
 1. ALL CURBING, PAVEMENT, SIDEWALKS, LAWN AREAS, STRIPING, DRIVEWAYS, TRAFFIC SIGNALS, LOOPS, FENCES, ETC. MUST BE RESTORED IN KIND AND/OR TO MUNICIPAL STANDARDS.

DETAIL VIEW B
 SHEET 1 - 32

nationalgrid
 THE NATIONAL GRID
 IFC

| NO. | DESCRIPTION | DATE | BY | CHKD. | APP. |
|-----|-------------|------|----|-------|------|
| | | | | | |
| | | | | | |
| | | | | | |
| | | | | | |

LIBERTY TAIL AVE @ APPLICATION ST
 REGULATORY STUDY REPLEASUREMENT
 LIBERTY TAIL AVE @ APPLICATION ST
 SHEET 1A
 INLET TIE-IN DETAILS

DATE: 08/14
 DRAWING NO.:
 SHEET NO.: 09

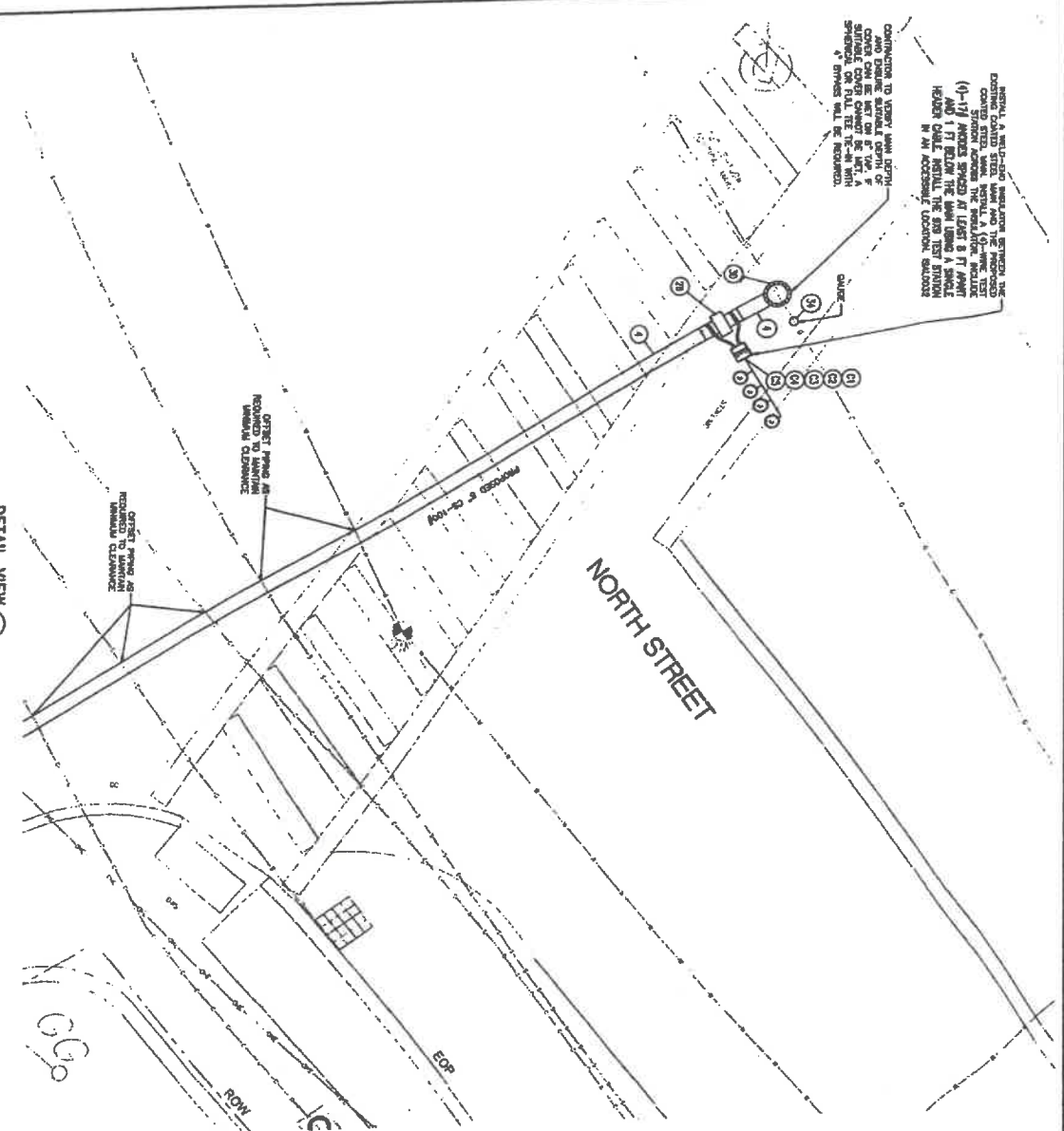

CONNECTION TO UTILITY MAINS BEYOND
 THE PROPERTY LINE SHALL BE MADE BY THE
 OWNER. THE UTILITY MAINS SHALL BE
 COVERED OR BE INSTALLED IN A
 MANNER THAT PROTECTS THE UTILITY MAINS
 FROM DAMAGE. THE UTILITY MAINS SHALL
 BE INSTALLED IN ACCORDANCE WITH THE
 CITY OF CHARLOTTE STANDARDS.

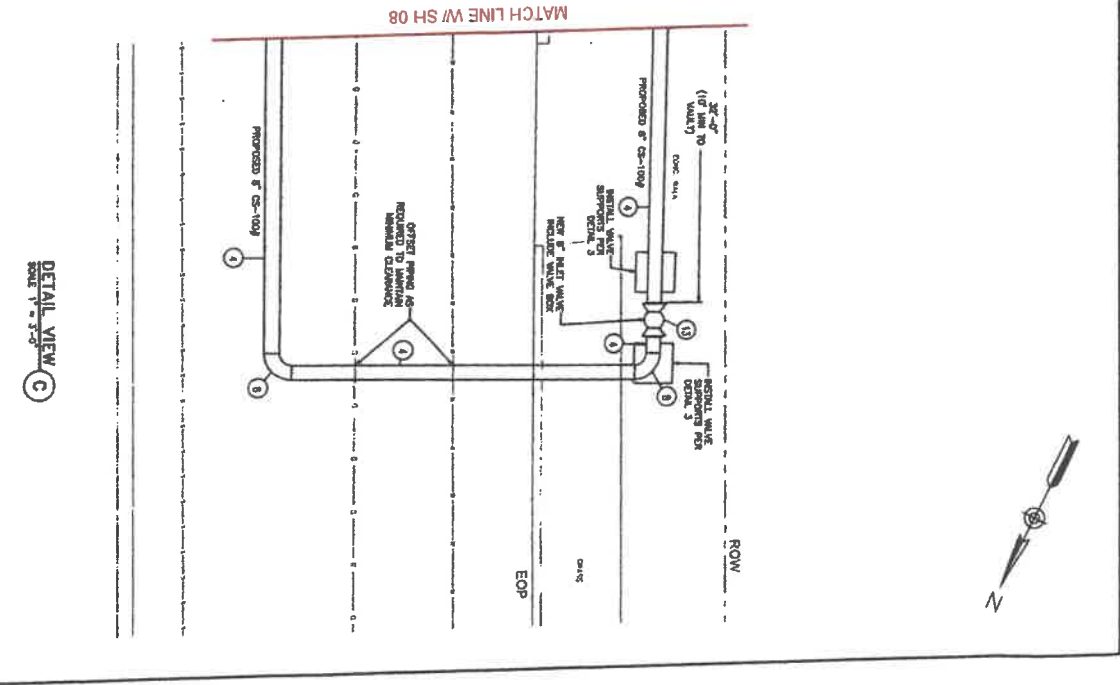

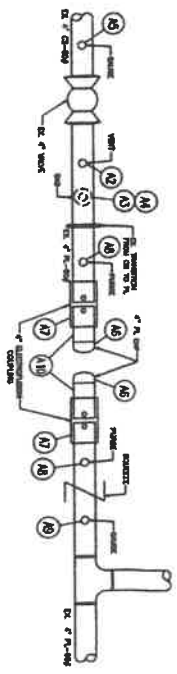
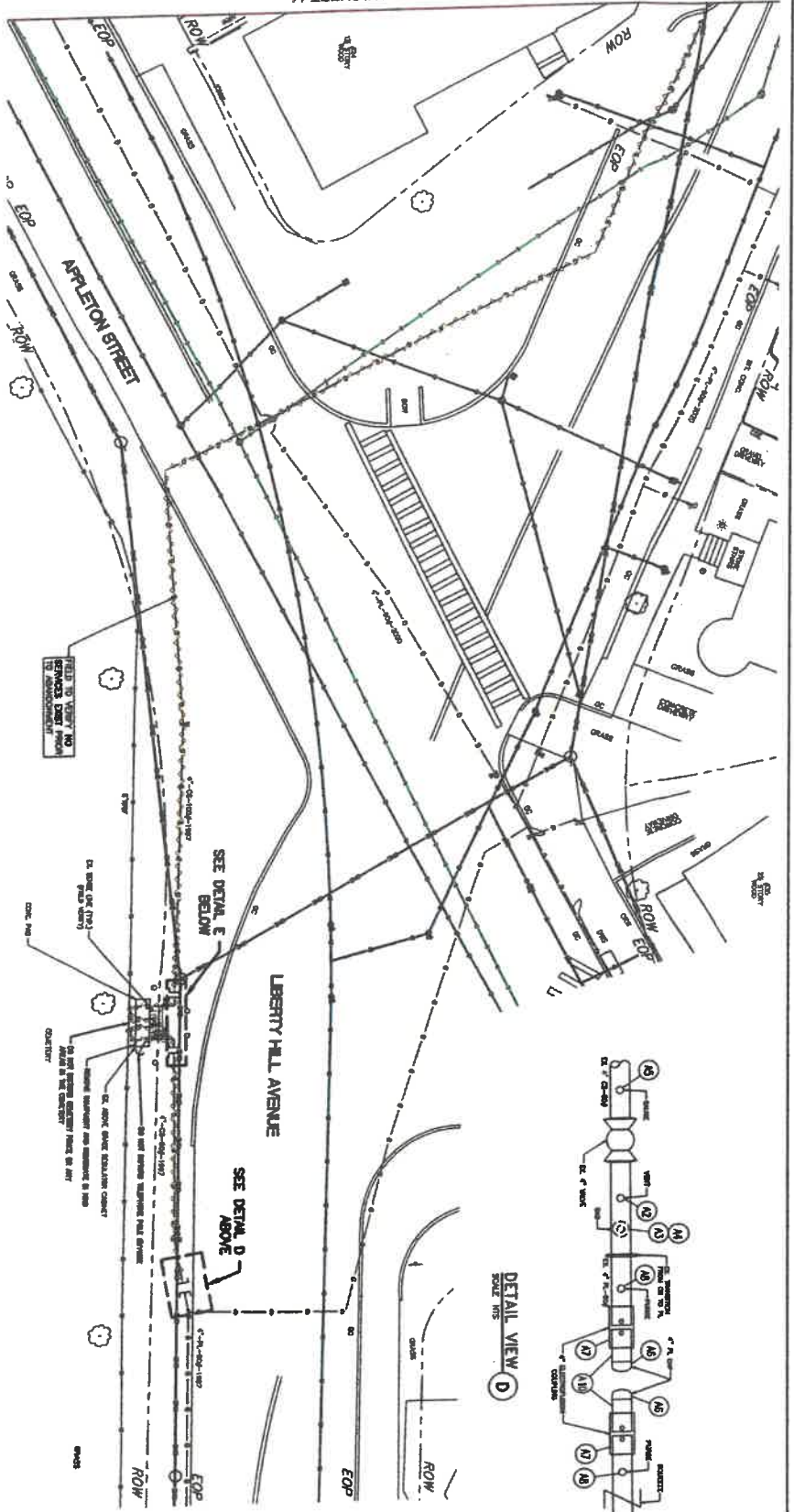

DETAIL VIEW D
SCALE: 1/8" = 1'-0"

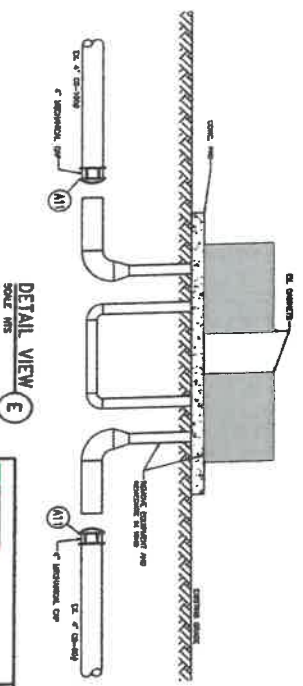

DETAIL VIEW E
SCALE: 1/8" = 1'-0"

- GENERAL NOTES:**
1. CONTRACTOR WHEN WORKING WITHIN 200 FT. OF A REGULATOR STATION,
 2. CONFIRM THAT ALL EXISTING CONTROL LINES ARE ABANDONED/CAPPED AS CLOSE TO THE MAIN AS POSSIBLE.
 3. REMOVE ALL REGULATORS, TELEMETRY, AND PIPING FROM THE OLD CABINET.
 4. REMOVE ABOVE GRADE CABINET, BOLLARDS, ETC.
 5. ALL CURBING, PAVEMENT, SIDEWALKS, LAWN AREAS, STRIPING, DRIVEWAYS, TRAFFIC SIGNALS LOOPS, FENCES, ETC. MUST BE RESTORED IN KIND AND/OR TO MUNICIPAL STANDARDS.

NOTE:
VERIFY LOCATION OF ALL CONTROL LINES PRIOR TO ANY CONSTRUCTION. CONFIRM THAT ALL CONTROL LINES ARE ABANDONED AFTER PURGING.

DESIGN BY: nationalgrid
 40111 VAN ALLEN
 11C



| NO. | DESCRIPTION | DATE | BY | CHECKED | DATE | BY | SCALE | STATUS |
|-----|----------------------|------------|----|---------|------------|----|--------------|---------|
| 1 | ISSUED FOR PERMIT | 10/20/2023 | JM | SM | 10/20/2023 | JM | 1/8" = 1'-0" | ISSUED |
| 2 | REVISED PER COMMENTS | 10/25/2023 | JM | SM | 10/25/2023 | JM | 1/8" = 1'-0" | REVISED |
| 3 | REVISED PER COMMENTS | 11/05/2023 | JM | SM | 11/05/2023 | JM | 1/8" = 1'-0" | REVISED |

LIBERTY HILL AVE @ APPLETON ST
 REGULATOR STATION REPLACEMENT
 LIBERTY HILL AVE @ APPLETON ST
 SALEM, IL
ABANDONMENT
 DATE: 10/20/23
 SHEET NO. 10

SR-SAL-0000217287 C-007

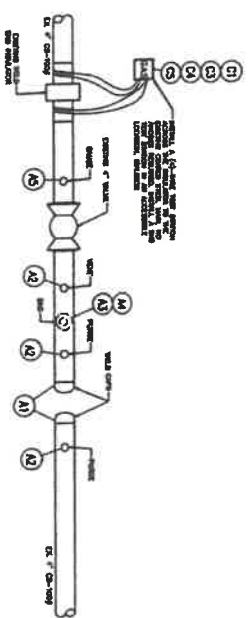
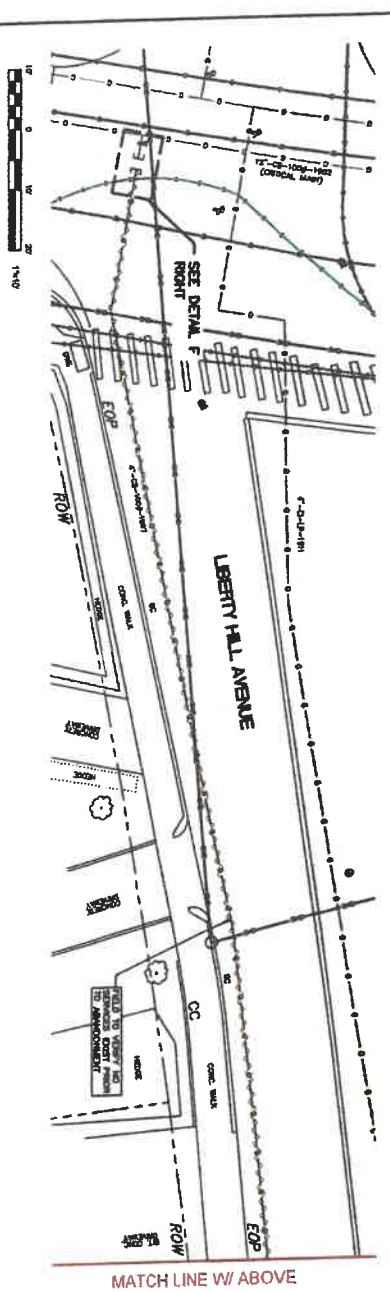
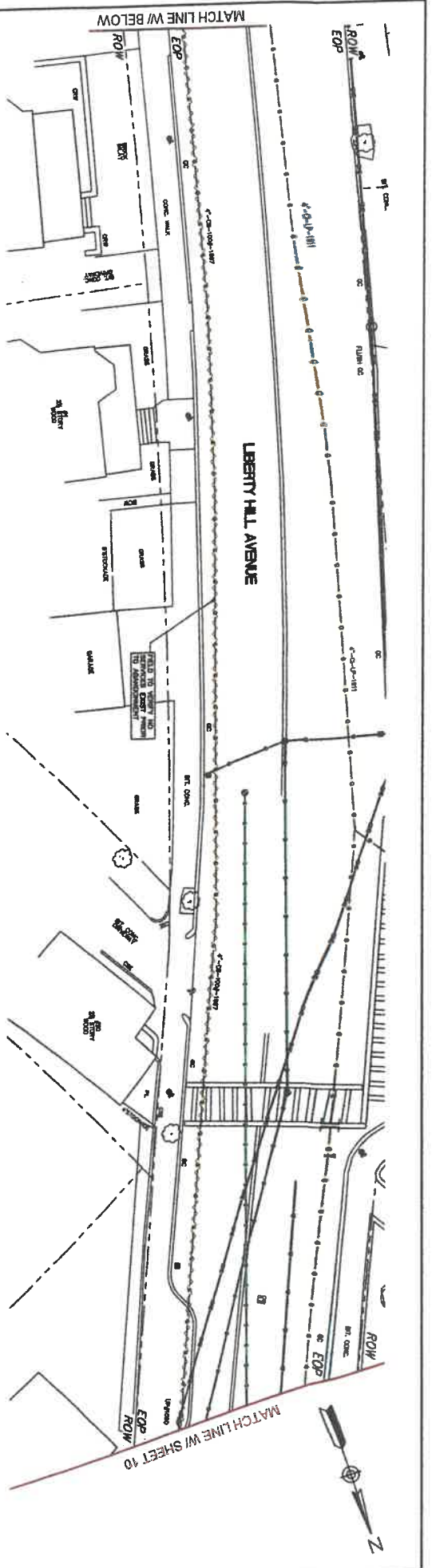

- GENERAL NOTES:**
1. CONTACT I&R WHEN WORKING WITHIN 200 FT OF A REGULATOR STATION.
 2. CONFIRM THAT ALL EXISTING CONTROL LINES ARE ABANDONED/CAPPED AS CLOSE TO THE MAIN AS POSSIBLE.
 3. REMOVE ALL REGULATORS, TELEMTRY, AND PIPING FROM THE OLD CABINET.
 4. REMOVE ABOVE GRADE CABINET, BOLLARDS, ETC.
 5. ALL CURBING, PAVEMENT, SIDEWALKS, LAWN AREAS, STRIPING, DRIVEWAYS, TRAFFIC SIGNALS LOOPS, FENCES, ETC, MUST BE RESTORED IN KIND AND/OR TO MUNICIPAL STANDARDS.

NOTE:
VERIFY LOCATION OF ALL CONTROL LINES PRIOR TO ANY CONSTRUCTION. CONFIRM THAT ALL CONTROL LINES ARE ABANDONED AFTER PURGING.



| NO. | DESCRIPTION | DATE | BY | CHECKED | DATE | BY |
|-----|-------------------|------|----|---------|------|----|
| 1 | ISSUED FOR PERMIT | | | | | |
| 2 | REVISIONS | | | | | |
| 3 | REVISIONS | | | | | |
| 4 | REVISIONS | | | | | |
| 5 | REVISIONS | | | | | |
| 6 | REVISIONS | | | | | |
| 7 | REVISIONS | | | | | |
| 8 | REVISIONS | | | | | |
| 9 | REVISIONS | | | | | |
| 10 | REVISIONS | | | | | |

LIBERTY HILL AVE @ REGULATOR ST
REGULATOR STATION RENOVATION
LIBERTY HILL AVE & APPELLATION ST
ABANDONMENT

SR-SAL-00000217287 C-005

11

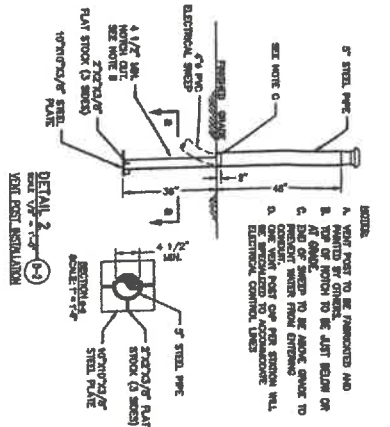
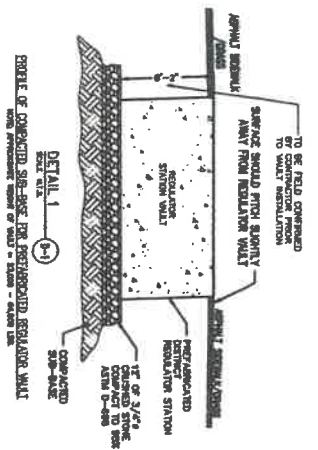

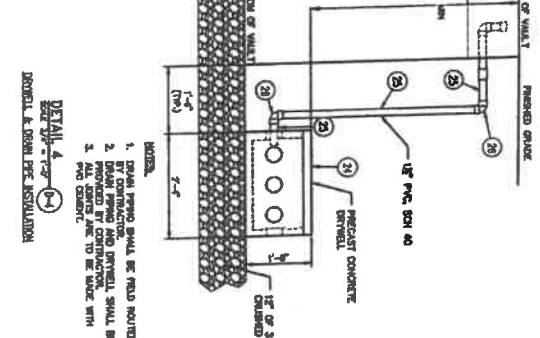
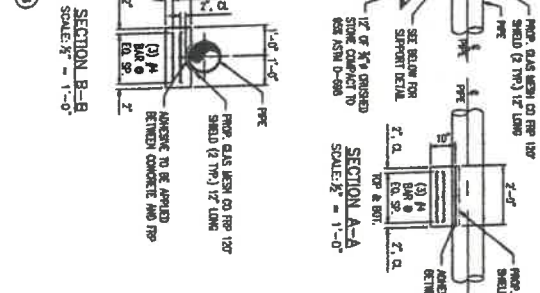
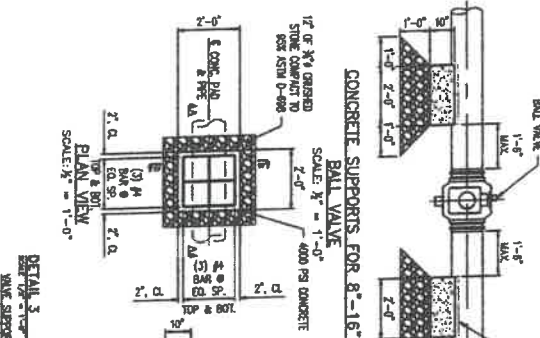

- CONCRETE NOTES:**
1. ALL CONCRETE SHOULD BE VIBRATED TO THE FULL DEPTH OF THE FORMS. CONCRETE SHOULD BE PLACED IN LAYERS NOT EXCEEDING 18\"/>
 - 2. CONCRETE SHALL BE CURED BY COVERING WITH A MOIST CURING MEMBRANE OR PAPER. CURING SHALL BE MAINTAINED THROUGHOUT THE CURE PERIOD.
 - 3. ALL CONCRETE SHALL BE PROTECTED FROM DAMAGE BY TRAFFIC AND EQUIPMENT UNTIL IT HAS GAINED SUFFICIENT STRENGTH TO SUPPORT SUCH LOADS.
 - 4. ALL CONCRETE SHALL BE PROTECTED FROM DAMAGE BY TRAFFIC AND EQUIPMENT UNTIL IT HAS GAINED SUFFICIENT STRENGTH TO SUPPORT SUCH LOADS.
 - 5. ALL CONCRETE SHALL BE PROTECTED FROM DAMAGE BY TRAFFIC AND EQUIPMENT UNTIL IT HAS GAINED SUFFICIENT STRENGTH TO SUPPORT SUCH LOADS.
 - 6. ALL CONCRETE SHALL BE PROTECTED FROM DAMAGE BY TRAFFIC AND EQUIPMENT UNTIL IT HAS GAINED SUFFICIENT STRENGTH TO SUPPORT SUCH LOADS.
 - 7. ALL CONCRETE SHALL BE PROTECTED FROM DAMAGE BY TRAFFIC AND EQUIPMENT UNTIL IT HAS GAINED SUFFICIENT STRENGTH TO SUPPORT SUCH LOADS.
 - 8. ALL CONCRETE SHALL BE PROTECTED FROM DAMAGE BY TRAFFIC AND EQUIPMENT UNTIL IT HAS GAINED SUFFICIENT STRENGTH TO SUPPORT SUCH LOADS.
 - 9. ALL CONCRETE SHALL BE PROTECTED FROM DAMAGE BY TRAFFIC AND EQUIPMENT UNTIL IT HAS GAINED SUFFICIENT STRENGTH TO SUPPORT SUCH LOADS.
 - 10. ALL CONCRETE SHALL BE PROTECTED FROM DAMAGE BY TRAFFIC AND EQUIPMENT UNTIL IT HAS GAINED SUFFICIENT STRENGTH TO SUPPORT SUCH LOADS.
 - 11. ALL CONCRETE SHALL BE PROTECTED FROM DAMAGE BY TRAFFIC AND EQUIPMENT UNTIL IT HAS GAINED SUFFICIENT STRENGTH TO SUPPORT SUCH LOADS.

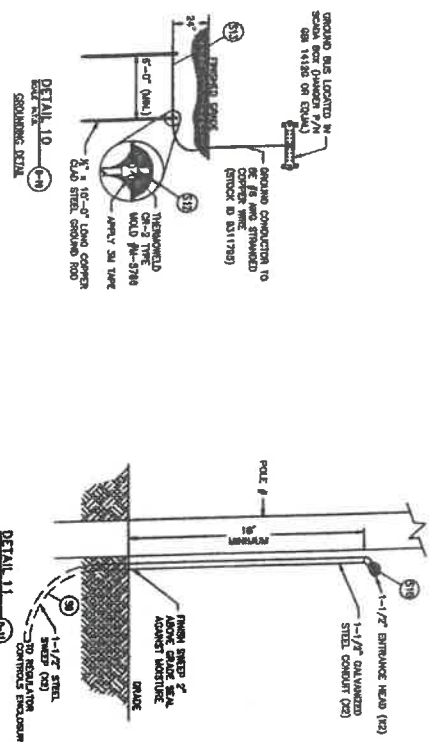
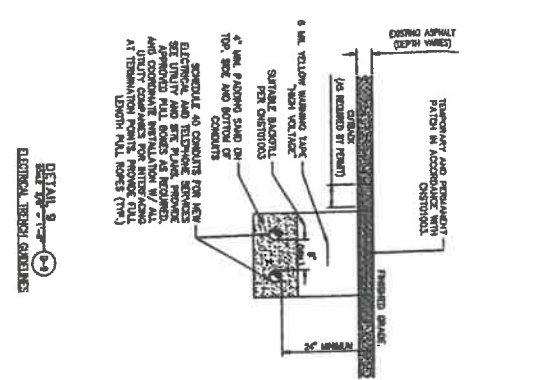
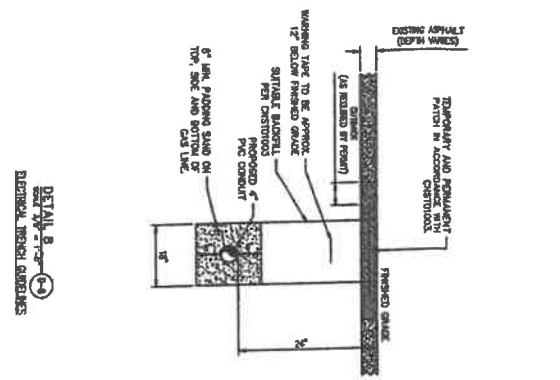
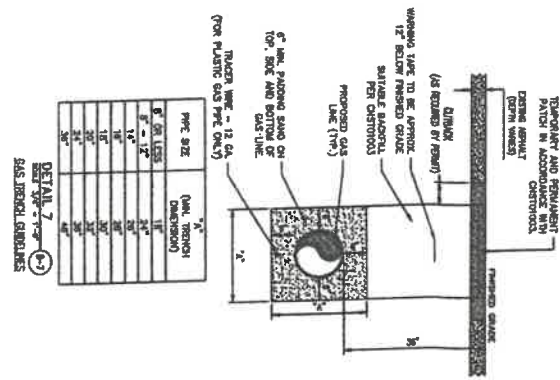
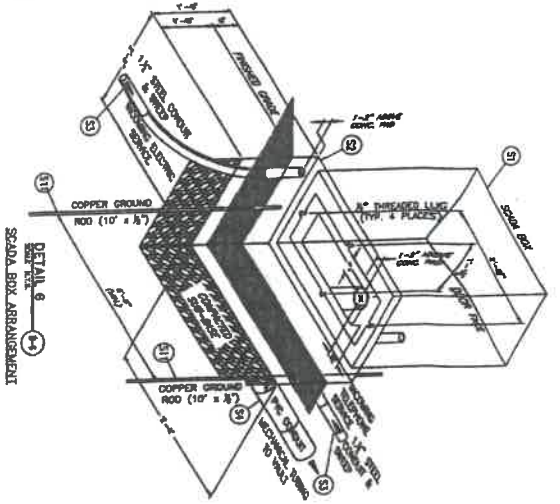

| NO. | DESCRIPTION | DATE | BY | CHECKED | APPROVED |
|-----|-------------------------|------|----|---------|----------|
| 1 | ISSUED FOR PERMIT | | | | |
| 2 | ISSUED FOR CONSTRUCTION | | | | |
| 3 | ISSUED FOR AS-BUILT | | | | |

LIBERTY HILL, INC. & AFFILIATION, ST. SAULS, MA
 DETAILS
 BR-SAL-0000217287 M-001
 12





DESIGN DEVELOPMENT SERVICES
PROFESSIONAL ENGINEERING & ARCHITECTURE
INC.

REGISTERED PROFESSIONAL ENGINEER
LIBERTY HILL, TEXAS



| NO. | DESCRIPTION | DATE | BY | CHECKED | DATE | BY | CHECKED |
|-----|-------------------|----------|----|---------|------|----|---------|
| 1 | ISSUED FOR PERMIT | 11/15/24 | JL | | | | |
| 2 | ISSUED FOR PERMIT | 11/15/24 | JL | | | | |
| 3 | ISSUED FOR PERMIT | 11/15/24 | JL | | | | |
| 4 | ISSUED FOR PERMIT | 11/15/24 | JL | | | | |
| 5 | ISSUED FOR PERMIT | 11/15/24 | JL | | | | |
| 6 | ISSUED FOR PERMIT | 11/15/24 | JL | | | | |
| 7 | ISSUED FOR PERMIT | 11/15/24 | JL | | | | |
| 8 | ISSUED FOR PERMIT | 11/15/24 | JL | | | | |
| 9 | ISSUED FOR PERMIT | 11/15/24 | JL | | | | |
| 10 | ISSUED FOR PERMIT | 11/15/24 | JL | | | | |
| 11 | ISSUED FOR PERMIT | 11/15/24 | JL | | | | |
| 12 | ISSUED FOR PERMIT | 11/15/24 | JL | | | | |
| 13 | ISSUED FOR PERMIT | 11/15/24 | JL | | | | |

LIBERTY HILL, TX & QUINCY, IL
REGULATORY STATION REPLACEMENT
LIBERTY HILL, TX & QUINCY, IL
SHEETS

DETAILS

BR-SAL-00000217967-M-002



CITY OF SALEM, MASSACHUSETTS

JEAN A. LEVESQUE COMMUNITY LIFE CENTER
401 Bridge Street, Salem MA 01970
Tel. (978) 744-0180 (978) 744-0924

Kimberley Driscoll
MAYOR

Trish O'Brien
Superintendent

SALEM COMMON, WILLOWS SHELL, OPEN SPACE PERMIT APPLICATION 60 Day Notice Required If P&R Commission Approval is needed

- 1) Name of Applicant/Organization: Emily Lonergan (mental makeover)
Street address: 15 Ocean ave. City: Salem State: MA
Contact Person: Ashley Stewes email: info@highsem.com Ph: 978 594 7050
- 2) Is Applicant/Organization Salem Based: Yes No (please circle one)
Is Applicant/Organization All Volunteer: Yes No (please see Policy for description)
If Registered, provide Nonprofit EIN# 87-2599431 Or Mass. Business ID # ---
- 3) Space requested: Salem Common Date Requested: Sunday, July 31, 2022
- 4) Event start time: 9 AM Event end time: 12 PM
- 5) Set up start time: 8 AM Breakdown end time: 1 PM
- 6) Event Description: The World Needs You Here 3 mile walk (see attached)
- 7) Est. number of attendees/participants: 500 Fee to attend/participate: YES or NO
- 8) Requesting Amplified Sound: YES NO If YES, A/S Start Time: 9 AM End Time: 12 PM
- 9) Power Requested: YES NO If YES, Time ON: --- Time OFF: ---
- 10) Lights Requested: YES NO If YES, Time ON: --- Time OFF: ---
- 11) Vendors Requested: YES NO If YES, How Many 6 Vendor Product: giveaways/samples
- 12) Canopies/Tents YES NO If YES, How Many 6 What Size: 10 FT
- 13) Other Misc. Requests: NA
- 14) Is the Space being requested to be used as a Fundraiser: YES NO

APPLICANT SIGNATURE: Emily Lonergan DATE: 1/12/22

For office use only--- Date received: 1/20/22 Date available Yes/No
 Fee: _____ Date Fee Paid: _____ Fee Received By: _____
 Commission Decision needed? Yes/No _____ Date Approved/Denied: _____
 Comments/Restriction: _____
 Director Approval: [Signature] Date: _____

All Races/Walks/Parades Are Required to Recycle and Remove Trash.
Please Explain Your Plan (Will You Bring to North Shore Recycled Fibre on 53 Jefferson Ave. Open 24 Hours to
Your Home, Curbside, or Other?) If You Have Questions about Recycling, Please Contact Public Rest for More
Information 978-619-5679
Curbside for trash + recycling will be fine

On-site EMT Ambulance Service (Required) EA initial
Please Attach a Map of Route With the Following Items:

- 1 Race/Walk Course
- 2 Direction of Runners Through the Race/Walk course
- 3 Starting and Finishing Points
- 4 Meeting Points For Racers Before and After the Race/Walk
- 5 Last year's race financials

Certificate of Insurance Attached? Yes No (policy renews 3/6/22)

A certificate of insurance for general liability naming the City of Salem as primary additional insured for amount not less than \$1,000,000 combined single limit for injury or death or property damages (including loss of use) in any one occurrence, and \$1,000,000 general aggregate coverage. (The City of Salem reserves the right to increase coverage minimum if event presents extraordinary risk).

RELEASE & INDEMNITY AGREEMENT APPLICANT'S SIGNATURE The undersigned Sponsor, by signature below, shall defend, indemnify, and hold the City of Salem, its officers, agents and employees, harmless against all liability, loss, or expenses, including attorney's fees, and against all claims, actions or judgments based upon or arising out of damage or injury (including death) to persons or property caused by any act or omission of an act sustained in any way in connections with the performance of this event or by conditions created thereby, or based upon violation of any statute, ordinance or regulation. This contractual indemnity provision does not abrogate common law or statutory liability and indemnification to the City of Salem, but is in addition to such common law or statutory provisions.

Emily Lonogan Date: 1/12/22
Applicant's signature

Emily Lonogan
Name of applicant

A copy of this permit will be sent to the applicant upon approval. Please call Park, Recreation & Community Services if you have any questions. 978-744-0924

CITY USE ONLY
Payment Received: _____ Date Permit Issued: _____ Date Permit Mailed to Applicant: _____
Approved By: _____

[Signature]
Director (Or Designee) of Salem Park, Recreation & Community Services

[Signature]
Salem Police Department

Effective date of form: 2/8/12
Revised date of form: 1/1/18

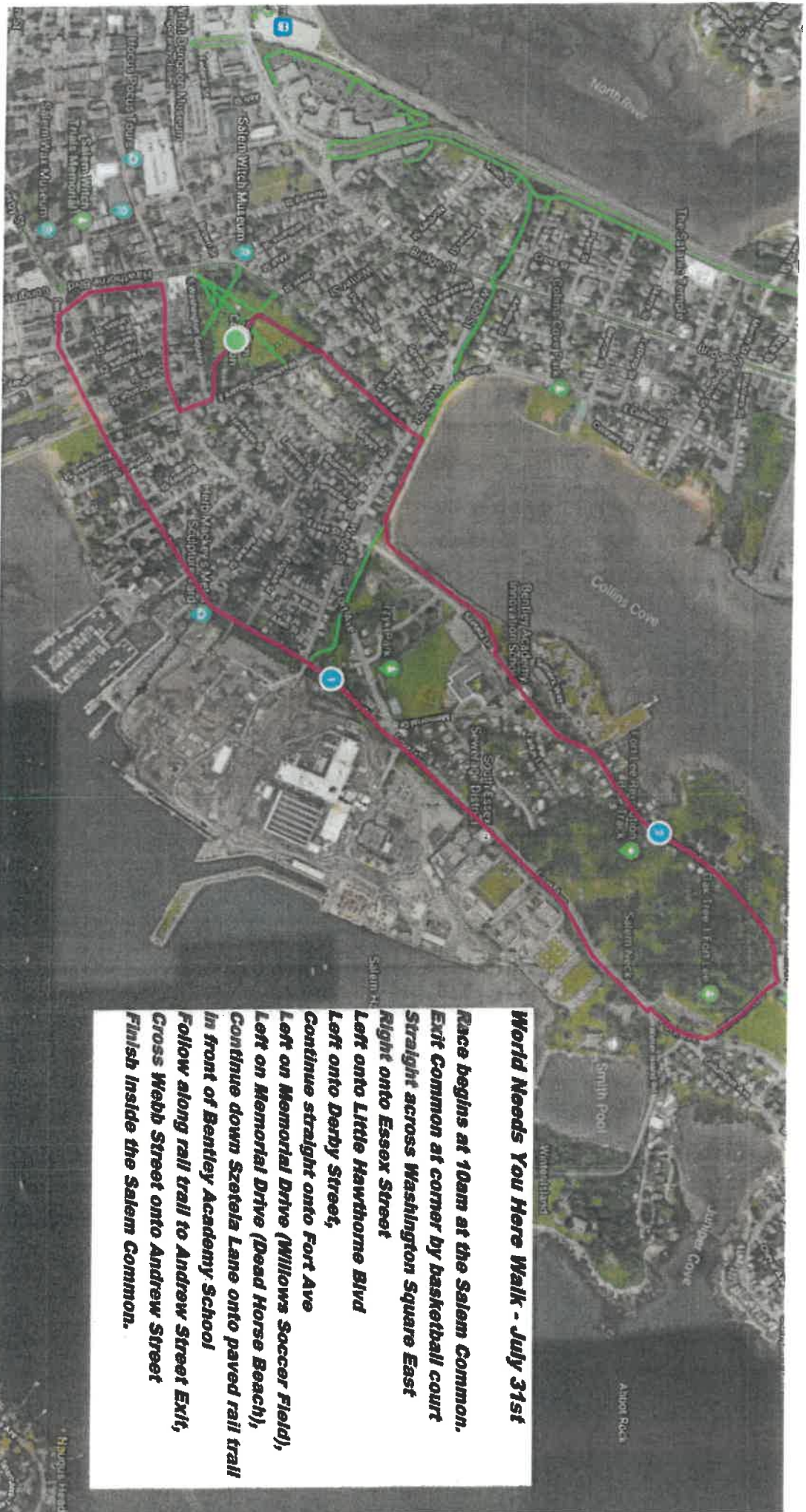

World Needs You Here Walk - July 31st

Race begins at 10am at the Salem Common.

Exit Common at corner by basketball court

Straight across Washington Square East

Right onto Essex Street

Left onto Little Hawthorne Blvd

Left onto Derby Street,

Continue straight onto Fort Ave

Left on Memorial Drive (Willows Soccer Field),

Continue down Szetela Lane onto paved rail trail

in front of Bentley Academy School

Follow along rail trail to Andrew Street Exit,

Cross Webb Street onto Andrew Street

Finish inside the Salem Common.

January 11, 2022

Attn: Salem City Council, Park and Rec Commission, Salem Police Department

We are interested in hosting this event in Salem, because we cherish the community, we live in. Having been born and grown up in Salem, all three of us consider our community to be one of the most vital aspects of what we do at Mental Makeover. In addition, having just become a verified non-profit organization and having had so much support from our community over the last three and a half years, we wanted our first event as a non-profit to be in Salem and to honor our dear friend, Sara Sarion, who we lost in May of 2020. As imagined, we haven't been able to celebrate Sara's life and impact on the Salem Community due to the pandemic and we feel Sunday, May 15th, the second anniversary of her death would be a momentous occasion.

We decided to settle on "The World Needs You Here" 3 mile walk because of the unfortunate tragedies Salem has experienced in the past few years. Not only do we want to honor and grieve for the people we've lost, but we also want our community to know that even if they are struggling with their mental health or are feeling down, we are here for them and there are people that care about them. To make sure they know that the world needs them here. This is the first of many events we are looking to introduce around the North Shore as we grow as an organization, and we are very excited to host it right in our hometown!

As this sort of event is a little out of our wheelhouse, we've brought Ashley Steeves and her team on from High5EM, who is very experienced in hosting these events, also born and raised in Salem, and fellow alumnus of Salem High School who knew Sara and her family.

Looking forward to this event. We appreciate any/all support you can extend to us and our organization.

Thank You,



Christiaan Van De Stadt



Emily Lonergan



Brandon Mustafaraj

FEATURED

In loving memory of Sas

Mental health advocacy group continues Salem High volleyball standout's legacy

By Dustin Luca Staff Writer

Dec 21, 2020

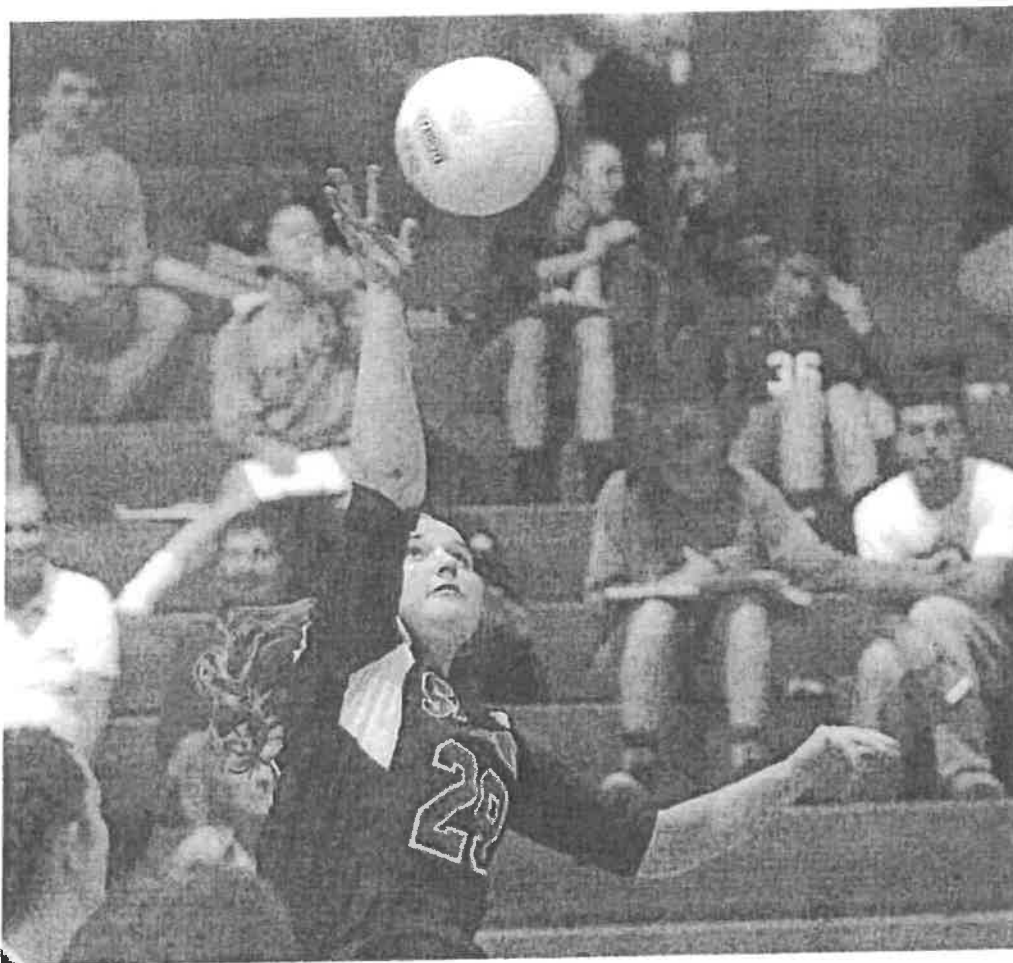

File Photo Sarah Starion, wearing number 29 in this Sept. 2016 file photo, rears back to smash the volleyball over the net in a match against Peabody.



SALEM — Sarah "Sas" Starion had a contagious smile and motivating confidence that spread like her favorite Maya Angelou quote: "Your legacy is every life you touch."

"She wrote that on the whiteboard a lot, her journals," said Emily Starion, her older sister. "She lived by it."

But Sarah Starion had a darker side that didn't get as much sunlight as the warmth she gave to others. Now, just months after she took her own life, she has inspired a group of Salem High graduates to keep her message alive through Mental Makeover, an advocacy organization they started in 2018 to fight the stigma associated with talking about mental health struggles.

"The constant message is that you're not alone," Emily Starion said. "There's so many people who feel this way and the more you talk about it, the better it gets."

Meet Sas

On June 2, 2017, Sarah Starion took the stage at Salem High's graduation alongside class co-president Jared Lubas. Decked out in red from head to toe, the three-year varsity volleyball standout smiled as she addressed her classmates.

"I went through three years of high school trying to be a part of every extra-curricular activity I possibly could, just to look good on paper," she said. "In my senior year, I found something that made me happy, and I chose to do it for myself — I started working at Gulu-Gulu Café as part of the school's co-op program."

It was there, Starion said, that she discovered how much she was maturing as her time in Salem started winding down.

"Embrace yourself and acknowledge the successes your life will bring you," Starion told her classmates. "Know your potential, and live off your strengths, and work through your weaknesses. Let each guide you to a balance life — being well-rounded is important, but being balanced is everything."

Though Starion hasn't been at Salem High in three years, her impact is still felt there. In the fence by the high school pedestrian bridge over Highland Avenue, red plastic cups spell out "SAS" — Starion's nickname — for all to see.

"There probably aren't enough words in the English language to be able to describe who Sarah was," said Angi Giancola, head coach of Salem High's junior varsity volleyball program. "Sarah was one of the most infectious and just incredible students I've had the privilege to work with. She was goofy, always confident about herself and definitely projected an air of confidence about her that was really inspiring to her teammates."

Sarah Starion would eventually become best known by Sas. The nickname, Emily Starion said, has ties to their grandfather.

"She was always sassy when she was younger. Sassafras, we'd call her," her older sister said. "She was very mad that her middle name wasn't Ann — that my middle name was Ann."

That's because Sarah's middle name is Grace, and SGS isn't as pronounceable a set of initials as SAS.

"She was just the life of the party, a huge sun," Emily Starion said. "She was always just good energy to be around, never bad energy."

That made it even harder to lose her.

'No, you're lying'

Starion was a University of Vermont junior studying food systems in the College of Agriculture and Life Sciences when she died. School newspaper The Vermont Cynic reported that she died unexpectedly in her apartment on May 14. She was 21.

A community-wide email from Annie Stevens, the school's vice provost for student affairs, extended "our deepest condolences to Sarah's family. Our sincere thoughts of care and sympathy are also extended to the friends, faculty, and staff who knew her." A GoFundMe campaign to help pay for memorial services quickly came together and raised more than \$23,000, blowing past its \$10,000 goal.

The news was punishing for Starion's family back home. Emily Starion recalled the last time she saw her little sister — on Mother's Day, "and I didn't know it would be the last."

"When I found out, I was more shocked," Emily Starion said. "It was like a 'no, you're lying' kind of deal. It has had a huge impact on my life, and I'm starting to change my point of view on how I see things — more like life is too short, and you'll never know when it's the last time you'll see somebody."

The news also shocked Emily Lonergan, Christian van de Stadt, and Brandon Mustafaraj, the 2015 Salem High graduates behind Mental Makeover.

"I'll never forget the day I found out. Sarah was one of my teammates, one of my friends in high school, so that grief hitting me was like nothing else," Lonergan said. "We had already been doing this work and had Mental Makeover set up. We talked about these problems a lot, talked about how we can talk about suicide and suicide prevention."

"Those were topics in our work and social media," Lonergan continued. "But it just really hit me and came to life that this was real, that one of my friends had taken their life. It was scary, and that was the moment where I was like, 'I know I have to continue this work.'"

Keeping Sarah's legacy alive

Sarah Starion represented "the first time that someone we knew and grew up with suffered so immensely that they ended up taking their own life," van de Stadt said. "Using Sarah as kind of a vehicle to show that people aren't alone... originally, it was just a post we made on Instagram with the Salem witch on it. It was shared hundreds of times, and then we decided to make this merchandise collection."

The organization's online shop includes clothing donning encouraging phrases of togetherness. One hoodie reads, "you are so much more," while another says "the world is a better place with you in it."

One particular hoodie, however, carries the item name "In Loving Memory of SAS." It has seven words printed along the front: "Your legacy is every life you touch."

Proceeds from the hoodie go toward a scholarship being formed at Salem High.

The quote "has kind of been the cry of lament and joy, and celebration, in Sarah's life, in her passing," Giancola said. "We've wanted to consider the ways that Sas inspired us, touched our lives, motivated us to be the best versions of ourselves, and in turn, we really want to encourage people to be for others who Sarah was."

The essay prompt for the scholarship is still coming together, but it focuses on Starion's quote: what does this quote mean to you? How does your approach to life continue Sarah's legacy of life and love?

"She was always uniquely herself, so of course that meant insecurities and carrying burdens and the weight of things on behalf of other people, because she was incredibly empathetic," Giancola said. "When we think about... 'why is this significant to you, to carry on Sarah's legacy?' A lot of it is about, 'what does it mean to be with people in their suffering and celebrate with them in their joy?'"

And that, Giancola said, is what Mental Makeover is all about.

"For them to really use their platform to raise awareness and end the stigma... Emily (Lonergan) was a volleyball player for me too, and I'm so proud of them," Giancola said. "We can lament, grieve and be in the darkness, but we can also celebrate and rejoice Sarah."

For more information on Mental Makeover, visit mentalmakeovertoday.com.

|||

TRENDING VIDEO

City of Salem

In the year Two Thousand and Twenty-Two

An Ordinance to amend the zoning ordinance regarding buffer zones relative to marijuana establishments.

Section 1. Section 6.10.6 *General Provisions* of Chapter 6, Section 6.10 *Marijuana Establishments* is hereby amended by deleting paragraph (5) in its entirety and replacing it with the following:

“5. Pursuant to M.G.L.A. c. 94G, § 5(b)(3), a marijuana establishment shall not be located within five hundred (500) feet of a pre-existing public or private school providing education in kindergarten or any of grades 1 through 12.”

Section 2. This Ordinance shall take effect as provided by City Charter.

In City Council January 13, 2022

Referred to the Committee on Ordinances, Licenses and Legal Affairs co-posted with Committee of the Whole

In City Council January 27, 2022

Referred to the Planning Board to hold a Joint Public Meeting by a roll call vote of 11 yeas, 0 nays and 0 absent

Joint Public Hearing held on March 7, 2022

Joint Public Hearing Closed by a roll call vote of 11 yeas, 0 nays and 0 absent

Referred to the Planning Board for their review and recommendation by a roll call vote of 11 yeas, 0 nays, and 0 absent

In City Council March 24, 2022

Adopted for first passage by a roll call vote of 10 yeas, 1 nay, and 0 absent

ATTEST:

ILENE SIMONS
CITY CLERK

City of Salem

In the year Two Thousand and Twenty-Two

An Ordinance Relative to Traffic

Be it ordained by the City Council of the City of Salem, as follows:

Section 1. Section 75A – Parking prohibitions towing zone (October resident parking) of Article V-A is hereby amended by deleting the following streets from Section A - Temporary October Resident Permit Parking:

Becket Avenue, Bridge Street from Howard Street to Webb Street, Cabot Street from Cedar Street to Gardner Street, Cross Street from Saunders Street to Lemon Street, Derby Street from Palfrey Court to Fort Avenue, Essex Street from Flint Street to Monroe Street, Hawthorne Boulevard on the westerly side of the two-way section, Leavitt Street from Lafayette Street to Congress Street, Palmer Street from Lafayette Street to Congress Street

And inserting the following streets:

Barton Place, Beacon Street, Bridge Street from Howard Street to Beacon Street, Broad Street from Dalton Parkway to Jackson Street, Cabot Street from Cedar Street to Hancock Street, Conant Street, Cross Street, Cross Street Court, Dalton Parkway even side only (14-18 Dalton Pkwy), Derby Street from Webb Street to Fort Avenue, Essex Street from Boston Street to Monroe Street, Fowler Street, Gardner Street, Hancock Street from Cabot Street to Lafayette Street, Harrington Court, Leavitt Street from Lafayette Street to Perkins Street, North Pine Street, Palmer Street, Pearl Street, Perkins Street, Pingree Street, Prince Street Place, Saunders Street, South Pine Street, Warner Street

Section 2. This ordinance shall take effect as provided by City Charter.

In City Council March 24, 2022

Adopted for first passage by a roll call vote 11 yeas, 0 nays and 0 absent

ATTEST:

ILENE SIMONS
CITY CLERK

CITY OF SALEM

In the year Two Thousand and Twenty-two

An Ordinance to amend an Ordinance relative to Traffic – Handicap Parking

Be it Ordained by the City Council of the City of Salem, as follows:

Section 1. Chapter 42, Section 50B – “Handicap Parking – Time Limited” is hereby amended as follows:

REPEAL – Boardman Street – in front of #27 Boardman Street for a distance of twenty (20) feet

Section 2. This Ordinance shall take effect as provided by City Charter.

In City Council March 24, 2022

Adoptd for first passage by a roll call vote of 11 yeas, 0 nays and 0 absent

ATTEST:

ILENE SIMONS
CITY CLERK

CITY OF SALEM

In the year Two Thousand and Twenty-two

An Ordinance to amend an Ordinance relative to Traffic – Handicap Parking

Be it Ordained by the City Council of the City of Salem, as follows:

Section 1. Chapter 42, Section 50B – “Handicap Parking – Time Limited” is hereby amended as follows:

REPEAL – Lafayette Street – in front of #292 Lafayette Street for a distance of twenty (20) feet

Section 2. This Ordinance shall take effect as provided by City Charter.

In City Council March 24, 2022

Adopted for first passage by a roll call vote of 11 yeas, 0 nays and 0 absent

ATTEST:

**ILENE SIMONS
CITY CLERK**

CITY OF SALEM

In the year Two Thousand and Twenty-two

An Ordinance to amend an Ordinance relative to Traffic – Handicap Parking

Be it Ordained by the City Council of the City of Salem, as follows:

Section 1. Chapter 42, Section 50B – “Handicap Parking – Time Limited” is hereby amended as follows:

REPEAL – Lynde Street – in front of #10 Lynde Street for a distance of twenty (20) feet

Section 2. This Ordinance shall take effect as provided by City Charter.

In City Council March 24, 2022

Adopted for first passage by a roll call vote of 11 yeas, 0 nays and 0 absent

ATTEST:

ILENE SIMONS
CITY CLERK