

**ORDER FOR POLE AND WIRE LOCATIONS**

In the City of Salem, Massachusetts

Notice having been given and public hearing held, as provided by law,  
IT IS HEREBY ORDERED:

that Massachusetts Electric Company d/b/a National Grid and be and it is hereby granted a location for and permission to erect and maintain poles and wires to be placed thereon, together with such sustaining and protecting fixtures as said Company may deem necessary, in the public way or ways hereinafter referred to, as requested in petition of said Company dated the 7<sup>th</sup> day of February, 2023.

All construction under this order shall be in accordance with the following conditions:

Poles shall be of sound timber, and reasonable straight, and shall be set substantially at the points indicated upon the plan marked – Bridge St - Salem - Massachusetts.

No. 30646074 Dated: February 7, 2023. Filed with this order

There may be attached to said poles such wires, cables, and fixtures as needed in their business and all of said wires and cables shall be placed at a height of not less than twenty (20) feet from the ground.

The following are the public ways or part of ways along which the poles above referred to may be erected, and the number of poles which may be erected thereon under this order:

Bridge St - Massachusetts Electric Company d/b/a National Grid to install 1 SO Pole on Bridge St beginning at a point approximately 100 ft southwest of the centerline of the intersection of Bridge St and Flint St. Install new pole 598-1 at approximately 42.521031, -70.905965, approximately 56' NW, in line of existing Pole # 598, in the strip of dirt that separates the road and bike path.

I hereby certify that the foregoing order was adopted at a meeting of the City Council of the City/Town of \_\_\_\_\_, Massachusetts held on the \_\_\_\_\_ day of \_\_\_\_\_ 20 .

\_\_\_\_\_  
Massachusetts City/Town Clerk. 20 .

Received and entered in the records of location orders of the City/Town of \_\_\_\_\_  
Book \_\_\_\_\_ Page \_\_\_\_\_

Attest:  
City/Town Clerk

I hereby certify that on \_\_\_\_\_ 20 , at \_\_\_\_\_ o'clock, M

at \_\_\_\_\_ a public hearing was held on the petition of  
Massachusetts Electric Company d/b/a National Grid

for permission to erect the poles, wires, and fixtures described in the order herewith recorded, and that we mailed at least seven days before said hearing a written notice of the time and place of said hearing to each of the owners of real estate (as determined by the last preceding assessment for taxation) along the ways or parts of ways upon which the Company is permitted to erect poles, wires, and fixtures under said order. And that thereupon said order was duly adopted.

City/Town Clerk.

.....  
.....  
.....  
.....

Board or Council of Town or City, Massachusetts

**CERTIFICATE**





I hereby certify that the foregoing is a true copy of the location order and certificate of hearing with notice adopted by the \_\_\_\_\_ of the City of Massachusetts, on the \_\_\_\_\_ day of \_\_\_\_\_ 20\_\_\_\_, and recorded with the records of location orders of the said City, Book \_\_\_\_\_, Page \_\_\_\_\_. This certified copy is made under the provisions of Chapter 166 of General Laws and any additions thereto or amendments thereof.

Attest:  
City/Town Clerk



PETITION SKETCH  
 TOWN OF SUTTON  
 WORCESTER COUNTY

**Legend**

-  Proposed SO Pole
-  Existing SO Pole
-  Center Line
-  Property Line
-  Easement

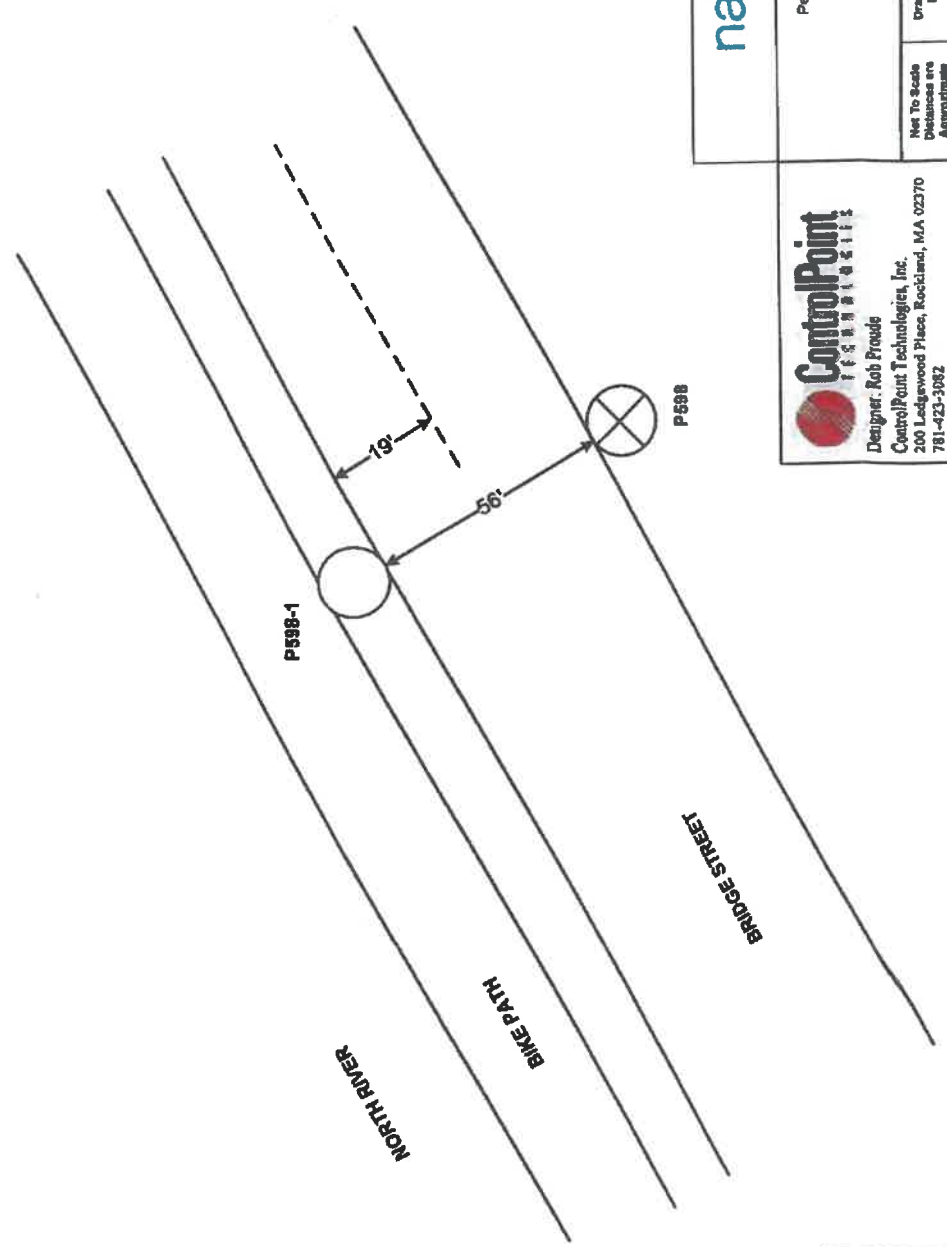

  
**ControlPoint**  
 PROFESSIONAL SURVEYING  
 Designer: Rob Probst  
 ControlPoint Technologies, Inc.  
 200 Ledgerwood Place, Rockland, MA 02370  
 781-423-3082

**nationalgrid**

Petition Sketch for Poles 598-1 Bridge St Sutton, MA WRR30646074		DRAWN BY: RMP	SKETCH # 308-46074	DATE 2/6/2023
Not To Scale Distances are Approximate		SHEET 1 OF 1		

The exact location of said  
 facilities to be established  
 by and upon the installation  
 and erection of the facilities  
 thereof.



**CITY OF SALEM, MASSACHUSETTS**

**Robert K. McCarthy**  
Mayor

March 9, 2023

Honorable Salem City Council  
Salem City Hall  
Salem, Massachusetts 01970

Ladies and Gentlemen of the City Council:

I appoint, subject to Council confirmation, Hannah Gathman to the Public Art Commission Board for one year term to expire March 9, 2024.

A resident of 6 Brown Street, Apt. 3, in Salem Ms. Gathman has a strong interest and involvement in the arts. She has a background in art history and museum studies, currently managing public arts projects and cultural planning. She has worked in large nonprofit settings at the Institute of Contemporary Art in Boston. She has been involved in a community arts council in Maine, and in the public sector as an Arts and Culture Planner at the Metropolitan Area Planning.

Ms. Gathman looks forward to working with the commission in future endeavors to benefit the City having a long history of community organizing and dedication to the arts and growing our cultural heritage.

Ms. Gathman fulfills the requirements of M.G.L. Chapter 138, section 4. I hope you will act quickly to approve Ms. Gathman appointment to the Salem Public Art Commission Board. Our city is fortunate indeed that he is willing to serve.

Very truly yours,

A handwritten signature in black ink, appearing to read "Robert K. McCarthy".

Robert K. McCarthy  
Acting Mayor



**CITY OF SALEM, MASSACHUSETTS**  
Kimberley Driscoll  
Mayor

**Application for Appointment to City Board or Commission**

For a complete list of City boards visit [www.salem.com/boards](http://www.salem.com/boards). Please send this form, along with a current resume, to [mayor@salem.com](mailto:mayor@salem.com) or mail to: Mayor's Office, City Hall, 93 Washington Street, Salem MA 01970.

**Name:** Hannah Gathman

**Address:** 8 Brown St, Apt 3, Salem, MA 01970

**Email:** hgathman@gmail.com

**Daytime Phone:** 573-574-4135

**Evening Phone:** 573-574-4135

**Current occupation:** Arts and Culture Planner

**Board or commission in which you are interested:** Public Art Commission

**Why are you interested in serving on this board or commission?**

My personal and professional life has always included a strong interest and involvement in the arts. I have a background in art history and museum studies, current professional experience managing public art projects and cultural planning, and a belief that the arts are an essential part of individual and community well-being! As a traditional folk musician involved in Salem's Irish music scene, I'm also interested in exploring ways that the City can support live music as a community benefit.

**In addition to the experience listed in your attached resume, what specific skills or expertise do you believe you can bring to this board or commission?**

My career so far has centered around increasing public engagement with the arts. I have worked in large nonprofit settings (the ICA in Boston), tiny nonprofit settings (running a community arts council in Maine), and in the public sector (my current role as an Arts and Culture Planner at the Metropolitan Area Planning Council).

I believe my background in arts management, art history, and municipal relations give me the tools to help advance the PAC's mission, and I bring a congenial attitude and strong attention to detail that I think could be useful assets for this board!

**If you are currently serving on any other City boards, please indicate which:**

**Signature:** 

**Date:** 1/31/2023

HANNAH C. H. GATHMAN

573.576.4135 • hgathman@gmail.com • she/her

OTHER PROFESSIONAL EXPERIENCE

DESERT OF MAINE CENTER FOR ARTS & ECOLOGY

2021

Interim Executive Director

- Led newly-formed nonprofit organization through its first year on site at an iconic tourist destination.
- Spearheaded all education, arts, and community programming initiatives, e.g. field trips, workshops, concerts.
- Prepared materials for municipal bodies, e.g. Town Council, Planning Board, and Project Review Board, and presented at relevant town meetings to advocate for relevant municipal policy.
- Organized and led board of directors meetings and all strategic conversations to guide the organization's future.
- Created and tracked annual operating budget; performed bookkeeping using Quickbooks Online.

ARTS & CULTURAL ALLIANCE OF FREEPORT

2018-2019

Interim Director

- Hired as the organization's first professional staff member; spearheaded all governance, programming, marketing, and budgeting for a young community arts council serving Freeport, Durham, and Pownal, Maine.
- Created programming and partnerships to foster regional collaboration and access to the arts, including *Arts & Culture Alive*, a professional development series, workshops for local youth, and the Freeport Folk Festival.
- Launched the comprehensive *Campaign for Meetinghouse Arts*; secured a \$130,000 TIF grant from the Town of Freeport and the organization's first grant from the Maine Arts Commission.
- Established community partnerships with the Freeport Community Library, Freeport Historical Society, RSU5 school district, Chamber of Commerce, and Economic Development Corporation to advocate for the community's creative economy.
- Drafted the annual operating budget for review by the Finance Committee and Board of Directors; tracked all organizational expenses and revenues.

BOSTON UNIVERSITY

Assistant Director, Programs and Events

2009-2012

Boston University Development and Alumni Relations

- Organized marquee alumni events and weekends, drawing 10,000+ attendees annually.
- Collaborated with Schools, Colleges, and initiatives across the University to create niche programming leveraging BU's academic, athletic, and cultural assets.
- Coordinated alumni volunteer committee meetings and initiatives.

*Promoted to Assistant Director from Programs and Events Coordinator in 2011.*

VOLUNTEER EXPERIENCE

MAINE NEEDS: Board of Directors, Development Chair

2021-2023

MAINE PUBLIC: Community Advisory Board

2019-2022

GREATER FREEPORT CHAMBER OF COMMERCE: Board of Directors

2018-2019

BIG SISTER ASSOCIATION OF GREATER BOSTON: Big Sister/Mentor

2009-2019

TECHNICAL SKILLS

- Salesforce, Blackbaud (Raiser's Edge, Luminare), Tessitura, and Microsoft Access CRM systems
- MailChimp and Constant Contact email marketing systems
- Website maintenance and design via SquareSpace, Wordpress, Wix, and Blogger platforms
- Publication and digital graphic design
- Facebook, Twitter, Instagram, TikTok, and Snapchat account management

HOBBIES

- Traditional Irish music, garment design and sewing, accepting invitations to join book clubs



## CITY OF SALEM, MASSACHUSETTS

Robert K. McCarthy  
Acting Mayor

March 9, 2023

Honorable Salem City Council  
Salem City Hall  
Salem, Massachusetts 01970

Ladies and Gentlemen of the City Council:

I am pleased to appoint Kristen Lindberg to the position of City Treasurer effective on March 13, 2023, to complete the remainder of an unexpired three-year term to conclude on January 31, 2025.

Ms. Lindberg comes to the City of Salem as an accomplished public finance leader with experience in municipal budgeting and municipal treasurer/collector operations. She has as served as the Assistant Chief Financial Officer for over 11 years, as well as Assistant Treasurer and Collector within the City of Gloucester, where she supervised a large staff and adhered to all departmental policies and procedures. Previously, she served as a Fiscal Analyst which focused her efforts for citywide budget presentation and analysis on key budget lines, which gives her nearly two decades of municipal financial experience. Additionally, in her most recent role, she served as the primary co-signer for approximately 35 civic bank accounts, maintained and reconciled \$60 million in cash book to bank statements within the General Ledger. With a careful expertise paid to monitoring accurate and timely tax collections and payment postings, we are thrilled to welcome Ms. Lindberg to the team as Treasurer.

I recommend confirmation of Ms. Lindberg's appointment and hope you will join me in welcoming her to her new role within the City of Salem.

Sincerely,

A handwritten signature in black ink, appearing to read "Robert K. McCarthy", is written over a horizontal line.

Robert K. McCarthy  
Acting Mayor

**Kristen Lindberg**  
7 Washington Square • Gloucester, MA  
617-538-9650 • klindberg1125@gmail.com

**Professional Experience:**

City of Gloucester

*Asst. CFO/Treasurer/Collector*

*July 2012-November 2022*

Managed daily operations of the Treasurer/Collector's Department including hiring, training, and continued supervision of staff while adhering to departmental policies and procedures. Enforced MGL and other statutory regulations and City Ordinances as necessary regarding treasurer and collector functions.

- Served as co-signer for approximately 35 bank accounts; maintained and reconciled \$60M cash book to bank statements and G/L.
- Received, recorded, and posted departmental turnovers, state aid, and federal and state grants; discussions with department heads relating thereto.
- Managed billing process and collections of approximately 150,000 municipal bills per year.
- Monitored accuracy of tax collections and payment posting; communicated with taxpayers, attorneys and others regarding complex issues with tax accounts and resolution thereof.
- Receivable reconciliation for DOR and financial statement reporting.
- Prepared Tax Title and followed through to redemption; Foreclosures.
- Issued Title V Loans, served as Parking Hearing Officer, oversaw Beach Sticker Sales Department, Betterment and Tax Deferrals, RFPs & Contracts for various departmental vendors, GIC bill, Notary Public.

City of Gloucester

*Fiscal Analyst*

*November 2008-November 2012*

Assisted with preparation of Citywide budget for presentation and approval of Mayor and Council.

- Performed analysis on the operating budget to assist in the development of monthly management reporting and annual budget documents.
- Calculated complex payroll projections for all City departments.
- Keyed departmental budgets to the system.
- Assisted in the preparation and financial monitoring of the Capital Improvement Budget.
- Assisted with cost calculations associated with collective bargaining and union contracts.
- Prepared debt payment spreadsheet to assist with reconciliation of debt invoices before payment issuance.
- Prepared budget transfers for the Treasurer's Department; reviewed and approved all other department's budget transfer requests.
- Assisted with reconciliation of HUD grants, Trust Funds and other reconciliations as requested by CFO.



**Self Employed**

*Bookkeeping/Tax Preparation*

*1995-2008*

Bookkeeping and tax preparation services for local businesses specializing in migration of manual bookkeeping to electronic records

- General ledger setup and maintenance, payroll processing and reporting, accounts payable and receivables, tax preparation

**Education**

Salem State College

*B.S. Business Administration/Accounting Concentration*

*1998-2002*

Mass Collector & Treasurer's Association

*Continuing Education*

*2012-2022*

- Collector - Courses completed, ready to test
- Treasurer - Courses ongoing

**Computer Skills**

Microsoft Office, Munis v11 & v2021, Google Suite, K2 Parking/Excise, Infinite Visions/BudgeSense, MS Govern/RevenueSense, Crystal Reports, Quickbase, Viewpoint/OpenGov Permitting, Quickbooks.



# CITY OF SALEM

In City Council,

March 23, 2023

Ordered:

That the sum of Seventy-Seven Thousand, Three Hundred Twenty-Nine Dollars and Nineteen Cents (\$77,329.19) be approved within the "Retirement Stabilization Fund-Vacation/Sick Leave Buyback" account (83113-5146) to be expended for the contractual buyback(s) listed below in accordance with the recommendation of His Honor the Mayor.

Name	Department	Amount
Jeanette Dubois	Salem School Department	\$18,209.76
Carlos Silva	Salem School Department	\$12,465.96
Marlene Lunt	Salem School Department	\$36,062.87
Laurie Panneton	Salem School Department	\$10,590.60
		<b>\$77,329.19</b>



**CITY OF SALEM, MASSACHUSETTS**

**Robert K. McCarthy**  
Mayor

March 23, 2023

To the City Council  
City Hall  
Salem, Massachusetts

Ladies and Gentlemen of the Council:

Enclosed herewith is a request for an appropriation of Seventy-Seven Thousand, Twenty-Nine Dollars and Nineteen Cents (\$77,329.19) appropriated in the "Retirement Stabilization Fund-Vacation/Sick Leave Buyback" account (83113-5146) to fund the retirement buyback costs to be expended for the employees listed below.

NAME	DEPARTMENT	AMOUNT
Jeanette Dubois	Salem School Dept	\$18,209.76
Carlos Silva	Salem School Dept	\$12,465.96
Marlene Lunt	Salem School Dept	\$36,062.87
Laurie Panneton	Salem School Dept	\$10,590.60
	Total:	<u>\$77,329.19</u>

I recommend passage of the accompanying Order.

Very truly yours,

  
Robert K. McCarthy  
Acting Mayor



ROBERT K. McCARTHY  
ACTING MAYOR

LISA B. CAMMARATA  
DIRECTOR OF HUMAN RESOURCES

CITY OF SALEM MASSACHUSETTS  
HUMAN RESOURCES  
98 WASHINGTON STREET, 3<sup>RD</sup> FLOOR  
SALEM, MASSACHUSETTS 01970  
TEL. 978-619-5630

MEMORANDUM

TO: Anna Freedman, Director of Finance  
DATE: March 3, 2023  
RE: Retirement Stabilization Fund

\*\*\*\*\*

Attached you will find a retirement buyback for a former employee of the Salem Public Schools.

This former employee is entitled to the following amount of sick leave and vacation buyback.

Jeanette Dubois

64.75 sick days @ \$205.76 per day	\$13,322.96
23.75 vacation days @ \$205.76 per day	\$ 4,886.80
<b>Total:</b>	<b>\$18,209.76</b>

In accordance with the July 2008 Policy, I am requesting you verify the availability of the funds from the Retirement Stabilization Fund, prepare the Council Order, and continue the process in order that my staff can input the information in MUNIS and issue payments to this former employee upon Council approval.

Thank you for your cooperation, and if you should have any questions, please do not hesitate to contact me.

**CITY OF SALEM**  
**APPROVAL-SICK DAYS/VACATION BUY-BACK**

From: Department School

Date 2/24/23

Authorized Signature: *Algebra Paul*  
Department Head/City or Business Manager/School

NAME: Jeannette Dubois

**CALCULATION**

VACATION DAYS # 23.75 @ \$ 205.76 = \$ 4,886.80

SICK DAYS # 64.75 @ \$ 205.76 = \$ ~~13,322.31~~ 13,322.96

PRO-RATED STIPENDS # \_\_\_\_\_ @ \$ \_\_\_\_\_ = \$ \_\_\_\_\_

OTHER # \_\_\_\_\_ @ \$ \_\_\_\_\_ = \$ \_\_\_\_\_

Total Amount Due: \$ ~~18,209.11~~ 18,209.76  
Please attach corresponding PAF or other backup to this sheet.

Reason: retirement

**For Human Resources' Use Only:**

- VACATION DAYS
- SICK DAYS
- PER ACCRUAL REPORT
- OTHER

Org and Object: 83113 - 5146

Recommendation: *[Signature]*  
 Approved  
HR Director/City or Superintendent/Schools



# Employee Accruals [CITY OF SALEM, MA - LIVE]

AB

Employee Master [CITY OF SALEM, MA - LIVE] > Employee Detail > Employee Accruals [CITY OF SALEM, MA - LIVE]

## Employee Identification

Employee \*  SSN  Last Name  First Name  MI  Suffix   
 Employee last name:

## Employee Accrual Information

Location	5100 - SCHOOL - SALEM HIGH SCHOOL	SOY Balance	80.0000
Group/BU	5001 - AFSCME SCHOOL LOCAL 294	Earned YTD	166.0000
Job Class *	5441 - COOK	Used YTD	56.0000
Type *	2 - VACATION	Available	190.0000
Table *	589 - CAFE 8 HRS PRIOR 7/1/08		

Send Accrual Threshold Alert  
 Active

Accr Date \*  Pending   
 Start Date \*  Liability   
 End Date \*  UOM  Review   
 Default Limit  Default Rate   
 Actual Limit  Actual Rate

October 26<sup>th</sup> 2022

To Whom it may concern I

Jeanette DeBois Give you my

Two week notice

Starting on Thursday Oct 27<sup>th</sup>  
My last day will be Thursday  
November 10<sup>th</sup>

Thank you

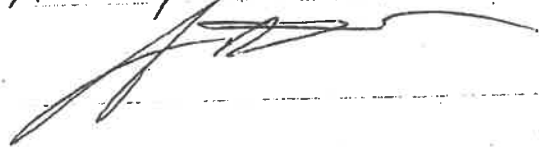
A handwritten signature in black ink, appearing to be 'Jeanette DeBois', written over a horizontal line.



## ARTICLE XI: MEAL PERIODS

All employees who work at least (6) hours per day shall be granted a meal period of thirty (30) minutes during each work shift. Whenever possible the meal period shall be scheduled at the middle of the shift.

## ARTICLE XII: SICK LEAVE

A. Sick leave shall be granted for personal sickness and for up to five days for sickness or injury in the immediate family. Immediate family is defined as set forth in Part One, Section A of Article XV11, entitled Funeral Leave. As such, Immediate family shall mean: Spouse, Mother, Father, Brother, Sister, Children, Grandparents, Grandchildren, Mother or Father-in-law, or any other dependent living in the household.

B. For absence due to illness in excess of (5) consecutive working days the Employer may require, for purposes of additional evidence, a certificate from a physician.

C. The parties recognize and agree to adhere to the Absence Control Policy as adopted by the City, excepting for the requirement of a certificate from a physician, which is governed by paragraph B above.

D. Employees absent because of an industrial accident may, if they so desire, draw from their sick leave credits, to make up the difference between the payment of compensation and their full week's pay.

E.1 On retirement or death of an employee who was employed on or before July 1, 2000 payment for accumulated unused sick leave will be made to the employee or his/her estate, up to a maximum of ninety (90) days.

E.2 On retirement or death of an employee who was employed on or after July 1, 2000 through June 30, 2002, payment for accumulated unused sick leave will be made to the employee or his/her estate, up to a maximum of forty-five (45) days.

E.3 Effective upon the execution of the 2011-2014 Agreement the District agrees to offer the following two options regarding Sick Leave Buyback to members on a voluntary basis.

**Option A – Members with a Service Date of 1/1/2003 or earlier.**

Upon written request by the member, the District agrees to provide the member with a one-time payment for fifty percent of the member's accrued sick leave, at the rate of one hundred twenty-five dollars (\$125.00) per day. The maximum number of days a member may receive payment for cannot exceed forty-five (45) days. Upon retirement from the District, any member who has received payment from the District in accordance with this Section will have his or her sick leave buyback in accordance with Section E. paragraphs 1 & 2 reduced by the number of days he or she has received hereunder. The member has the option to request the District deposit this one-time payment in the member's preferred deferred compensation plan.

#### **Option B – Members with a Service Date of 1/2/2003- 12/31/2012**

Upon written request by the member, the District agrees to provide the member with a one-time payment for fifty percent of the member's accrued sick leave, at the rate of fifty dollars (\$50.00) per day. The maximum number of days a member may receive payment for cannot exceed forty-five (45) days. Upon retirement from the District, any member who has received payment from the District in accordance with this provision will have his or her sick leave buyback in accordance with Section E. paragraphs 1 & 2 reduced by the number of days he or she received in accordance with this provision. The member has the option to request the District deposit this one-time payment in the member's preferred deferred compensation plan.

E. 4 Members hired on or after January 1, 2013 shall not be entitled to a buyback of sick days at retirement, but in the alternative, will be eligible to buy back, at the employee's daily rate, not to exceed two hundred fifty dollars (\$250.00) per day, up to two sick days per year. Payment shall be made in January following the end of the calendar year in which the employee had not used fifty percent (50%) of his or her sick leave accrual in the prior calendar year. The funds paid out shall be paid into a deferred compensation plan.

### **ARTICLE XIII: PERSONNEL POLICIES**

#### **A. Alcohol and Drug Policy**

The parties recognize and agree to adhere to the Alcohol and Drug Policy as adopted by the City of Salem. The parties recognize and agree to the Employee Assistance Program (EAP) Policy as adopted by the City of Salem.

#### **B. Inclement Weather**

1. When there is a two (2) hour delay for the opening of school for students:

## Alicia Brady

---

**From:** Paul Findlen <pfindlen@salemretirement.org>  
**Sent:** Friday, March 3, 2023 11:33 AM  
**To:** Brenna Gloudemans; Jamie Godjikian  
**Cc:** Alicia Brady; Lisa Cammarata  
**Subject:** RE: Buy Backs

**Caution:** This email originated from outside our system. Please do not click links or open attachments unless you recognize the sender and know the content is safe.

Hi Brenna,

Sure, no problem. Their retirement dates are as follows:

- Jeannette Dubois' retirement date is: 11/13/2022
- Carlos Silva's retirement date is: 12/16/2022

Please let me know if you need anything else.

Paul

Paul E. Findlen  
Executive Director  
Salem Contributory Retirement System  
20 Central Street, Suite 110  
Salem, MA 01970  
Office: (978) 745-8983  
Fax: (978) 745-4216  
[www.salemretirement.org](http://www.salemretirement.org)

**From:** Brenna Gloudemans <bgloudemans@salemk12.org>  
**Sent:** Friday, March 3, 2023 10:37 AM  
**To:** Paul Findlen <paul.findlen@salemret.com>; Paul Findlen <pfindlen@salemretirement.org>; Jamie Godjikian <jamie.godjikian@salemret.com>; Jamie Godjikian <jgodjikian@salemretirement.org>  
**Cc:** Alicia Brady <abrady@salem.com>; Lisa Cammarata <lcammarata@salem.com>  
**Subject:** Buy Backs

Good morning,

Can you please confirm the following former Salem district employees are now retired so city hall can process their buy backs? Thank you!

**Jeannette Dubois**  
**Carlos Silva**

Brenna Gloudemans | Payroll Coordinator

# Employee Master [CITY OF SALEM, MA - LIVE]

BG

Search Add Delete Print PDF Email Attach

## Employee Master [CITY OF SALEM, MA - LIVE]

### Employee Identification

Employee \*  SSN \*  Last Name \*  First Name \*  Middle Name   
 510190  DUBOIS  JEANNETTE

Preferred Name

Main Dates Demographics Address Payroll Mail Sort Last Change User Defined

### Dates

Inactive 11/10/2022 Code RES - RESIGNATION  
 Terminated Code

Birth \* 02/09/1958  
 Hired 10/03/1993  
 Service 10/03/1993  
 Permanent 10/03/1993

Orig Hire

Ret/Pension

Probation



ROBERT K. McCARTHY  
ACTING MAYOR

LISA B. CAMMARATA  
DIRECTOR OF HUMAN RESOURCES

CITY OF SALEM MASSACHUSETTS

HUMAN RESOURCES  
98 WASHINGTON STREET, 3<sup>RD</sup> FLOOR  
SALEM, MASSACHUSETTS 01970  
TEL. 978-619-5630

MEMORANDUM

TO: Anna Freedman, Director of Finance  
DATE: March 3, 2023  
RE: Retirement Stabilization Fund

\*\*\*\*\*

Attached you will find a retirement buyback for a former employee of the Salem Public Schools.

This former employee is entitled to the following amount of sick leave and vacation buyback.

Carlos Silva

45 sick days @ \$190.32 per day	\$8,564.40
20.50 vacation days @ \$190.32 per day	\$3,901.56
<b>Total:</b>	<b>\$12,465.96</b>

In accordance with the July 2008 Policy, I am requesting you verify the availability of the funds from the Retirement Stabilization Fund, prepare the Council Order, and continue the process in order that my staff can input the information in MUNIS and issue payments to this former employee upon Council approval.

Thank you for your cooperation, and if you should have any questions, please do not hesitate to contact me.

LHC

**CITY OF SALEM**  
**APPROVAL-SICK DAYS/VACATION BUY-BACK**

From: Department School

Date 2/24/23

Authorized Signature: Elegash Pawly  
Department Head/City or Business Manager/School

NAME: Carlos Silva

**CALCULATION**

VACATION DAYS # 20.50 @ \$ 190.32 = \$ 3,901.56 ✓

SICK DAYS # 45 @ \$ 190.32 = \$ 8,564.40 ✓

PRO-RATED STIPENDS # \_\_\_\_\_ @ \$ \_\_\_\_\_ = \$ \_\_\_\_\_

OTHER # \_\_\_\_\_ @ \$ \_\_\_\_\_ = \$ \_\_\_\_\_

**Total Amount Due:** \$ 12,465.96 ✓  
Please attach corresponding PAF or other backup to this sheet.

Reason: Retirement

**For Human Resources's Use Only:**

- VACATION DAYS
- SICK DAYS
- PER ACCRUAL REPORT
- OTHER

Org and Object: 83113 - 5146

Recommendation:  Approved  
[Signature]  
HR Director/City or Superintendent/Schools

# Employee Accruals [CITY OF SALEM, MA - LIVE]

BG

Close | 
 Accept | 
 Search | 
 Browse | 
 Add | 
 Update | 
 Delete | 
 Output | 
 Print | 
 Display | 
 PDF | 
 Save | 
 Excel | 
 Word | 
 Email | 
 Schedule

## Employee Accruals [CITY OF SALEM, MA - LIVE]

### Employee Identification

Employee \* 510262      SSN      Last Name SILVA      First Name CARLOS      MI A      Suffix A

### Employee Accrual Information

Location	5100 - SCHOOL - SALEM HIGH SCHOOL	SOY Balance	1820.5000
Group/BU	5001 - AFSCME SCHOOL LOCAL 294	Earned YTD	120.0000
Job Class *	5420 - BUILDING CUSTODIAN	Used YTD	9.5000
Type *	1 - SICK	Available	1931.0000
Table *	560 - CUSTODIAN SICK ACCRUAL		

Send Accrual Threshold Alert

Active

Pending .0000  
 Liability 45938.49

Accr Date \* 05/14/2016

Start Date \* 08/25/2014

Review

# Employee Accruals [CITY OF SALEM, MA - LIVE]

AB

Employee Master [CITY OF SALEM, MA - LIVE] > Employee Detail > Employee Accruals [CITY OF SALEM, MA - LIVE]

## Employee Identification

Employee \* 
 SSN 
 Last Name 
 First Name 
 MI 
 Suffix

## Employee Accrual Information

Location	5100 - SCHOOL - SALEM HIGH SCHOOL	SOY Balance	36.0000
Group/BU	5001 - AFSCME SCHOOL LOCAL 294	Earned YTD	200.0000
Job Class *	5420 - BUILDING CUSTODIAN	Used YTD	72.0000
Type *	2 - VACATION	Available	164.0000
Table *	560 - CUSTODIANS DOH AFTER 7/1/95		

Send Accrual Threshold Alert

Accr Date *	05/14/2001	Pending	.0000
Start Date *	08/25/2014	Liability	3901.56

Review

End Date *	12/31/9999	UOM	H
Default Limit	280.00	Default Rate	200.0000
Actual Limit	.00	Actual Rate	0.0000



## Alicia Brady

---

**From:** Paul Findlen <pfindlen@salemretirement.org>  
**Sent:** Friday, March 3, 2023 11:33 AM  
**To:** Brenna Gloudemans; Jamie Godjikian  
**Cc:** Alicia Brady; Lisa Cammarata  
**Subject:** RE: Buy Backs

**Caution:** This email originated from outside our system. Please do not click links or open attachments unless you recognize the sender and know the content is safe.

Hi Brenna,

Sure, no problem. Their retirement dates are as follows:

- Jeannette Dubois' retirement date is: 11/13/2022
- Carlos Silva's retirement date is: 12/16/2022

Please let me know if you need anything else.

Paul

Paul E. Findlen  
Executive Director  
Salem Contributory Retirement System  
20 Central Street, Suite 110  
Salem, MA 01970  
Office: (978) 745-8983  
Fax: (978) 745-4216  
[www.salemretirement.org](http://www.salemretirement.org)

**From:** Brenna Gloudemans <bgloudemans@salemk12.org>  
**Sent:** Friday, March 3, 2023 10:37 AM  
**To:** Paul Findlen <paul.findlen@salemret.com>; Paul Findlen <pfindlen@salemretirement.org>; Jamie Godjikian <jamie.godjikian@salemret.com>; Jamie Godjikian <jgodjikian@salemretirement.org>  
**Cc:** Alicia Brady <abrady@salem.com>; Lisa Cammarata <lcammarata@salem.com>  
**Subject:** Buy Backs

Good morning,

Can you please confirm the following former Salem district employees are now retired so city hall can process their buy backs? Thank you!

**Jeannette Dubois**  
**Carlos Silva**

Brenna Gloudemans | Payroll Coordinator

Carlos A. Silva  
27 Rockingham Street  
Lynn, MA 01902  
781 913-9398

RECEIVED

DEC 08 2022

S.P.S.  
Supt.'s Office

December 1, 2022

Dear Sirs,

Please accept this letter as my official notice of retirement from my position of High School Custodian with the City of Salem here at Salem High School.

It has been with great pleasure to alongside such great people here at Salem High and I will always appreciate the experience I gained during my time here.

Yours sincerely,

Carlos A. Silva



CC: Zissis Alepakis- Director of Building Services  
Superintendent of Schools- Dr. Stephen Zrike

## **ARTICLE XI: MEAL PERIODS**

All employees who work at least (6) hours per day shall be granted a meal period of thirty (30) minutes during each work shift. Whenever possible the meal period shall be scheduled at the middle of the shift.

## **ARTICLE XII: SICK LEAVE**

A. Sick leave shall be granted for personal sickness and for up to five days for sickness or injury in the immediate family. Immediate family is defined as set forth in Part One, Section A of Article XV11, entitled Funeral Leave. As such, Immediate family shall mean: Spouse, Mother, Father, Brother, Sister, Children, Grandparents, Grandchildren, Mother or Father-in-law, or any other dependent living in the household.

B. For absence due to illness in excess of (5) consecutive working days the Employer may require, for purposes of additional evidence, a certificate from a physician.

C. The parties recognize and agree to adhere to the Absence Control Policy as adopted by the City, excepting for the requirement of a certificate from a physician, which is governed by paragraph B above.

D. Employees absent because of an industrial accident may, if they so desire, draw from their sick leave credits, to make up the difference between the payment of compensation and their full week's pay.

E.1 On retirement or death of an employee who was employed on or before July 1, 2000 payment for accumulated unused sick leave will be made to the employee or his/her estate, up to a maximum of ninety (90) days.

E.2 On retirement or death of an employee who was employed on or after July 1, 2000 through June 30, 2002, payment for accumulated unused sick leave will be made to the employee or his/her estate, up to a maximum of forty-five (45) days.

E.3 Effective upon the execution of the 2011-2014 Agreement the District agrees to offer the following two options regarding Sick Leave Buyback to members on a voluntary basis.

**Option A – Members with a Service Date of 1/1/2003 or earlier.**

Upon written request by the member, the District agrees to provide the member with a one-time payment for fifty percent of the member's accrued sick leave, at the rate of one hundred twenty-five dollars (\$125.00) per day. The maximum number of days a member may receive payment for cannot exceed forty-five (45) days. Upon retirement from the District, any member who has received payment from the District in accordance with this Section will have his or her sick leave buyback in accordance with Section E. paragraphs 1 & 2 reduced by the number of days he or she has received hereunder. The member has the option to request the District deposit this one-time payment in the member's preferred deferred compensation plan.

**Option B – Members with a Service Date of 1/2/2003- 12/31/2012**

Upon written request by the member, the District agrees to provide the member with a one-time payment for fifty percent of the member's accrued sick leave, at the rate of fifty dollars (\$50.00) per day. The maximum number of days a member may receive payment for cannot exceed forty-five (45) days. Upon retirement from the District, any member who has received payment from the District in accordance with this provision will have his or her sick leave buyback in accordance with Section E. paragraphs 1 & 2 reduced by the number of days he or she received in accordance with this provision. The member has the option to request the District deposit this one-time payment in the member's preferred deferred compensation plan.

E. 4 Members hired on or after January 1, 2013 shall not be entitled to a buyback of sick days at retirement, but in the alternative, will be eligible to buy back, at the employee's daily rate, not to exceed two hundred fifty dollars (\$250.00) per day, up to two sick days per year. Payment shall be made in January following the end of the calendar year in which the employee had not used fifty percent (50%) of his or her sick leave accrual in the prior calendar year. The funds paid out shall be paid into a deferred compensation plan.

**ARTICLE XIII: PERSONNEL POLICIES**

**A. Alcohol and Drug Policy**

The parties recognize and agree to adhere to the Alcohol and Drug Policy as adopted by the City of Salem. The parties recognize and agree to the Employee Assistance Program (EAP) Policy as adopted by the City of Salem.

**B. Inclement Weather**

1. When there is a two (2) hour delay for the opening of school for students:

# Employee Master [CITY OF SALEM, MA - LIVE]

BG

Close | 
 Search | 
 Browse | 
 Add | 
 Update | 
 Delete | 
 Output | 
 Print | 
 Display | 
 PDF | 
 Save | 
 Email | 
 Schedule | 
 Attach | 
 D

## Employee Master [CITY OF SALEM, MA - LIVE]

### Employee Identification

Employee \* 510262 | SSN \* | Last Name \* SILVA | First Name \* CARLOS | Middle Name A

Preferred Name

Main | Dates | Demographics | Address | Payroll | Mail Sort | Last Change | User Defined

### Dates

Inactive 12/16/2022 | Code RET - RETIREMENT | Code

Birth \* 10/13/1950  
 Hired 05/14/2001  
 Service 05/14/2001  
 Permanent 05/14/2001  
 Orig Hire 05/14/2001

Ret/Pension  
 Probation tn



ROBERT K. McCARTHY  
ACTING MAYOR

LISA B. CAMMARATA  
DIRECTOR OF HUMAN RESOURCES

CITY OF SALEM MASSACHUSETTS

HUMAN RESOURCES  
98 WASHINGTON STREET, 3<sup>RD</sup> FLOOR  
SALEM, MASSACHUSETTS 01970  
TEL. 978-619-5630

MEMORANDUM

TO: Anna Freedman, Director of Finance  
DATE: March 3, 2023  
RE: Retirement Stabilization Fund

\*\*\*\*\*

Attached you will find a retirement buyback for a former employee of the Salem Public Schools.

This former employee is entitled to the following amount of sick leave buyback.

Marlene Lunt

76.50 sick days @ \$471.41 per day \$36,062.87

Total: \$36,062.87

In accordance with the July 2008 Policy, I am requesting you verify the availability of the funds from the Retirement Stabilization Fund, prepare the Council Order, and continue the process in order that my staff can input the information in MUNIS and issue payments to this former employee upon Council approval.

Thank you for your cooperation, and if you should have any questions, please do not hesitate to contact me.

**CITY OF SALEM**  
**APPROVAL-SICK DAYS/VACATION BUY-BACK**

From: Department School

Date 2/24/23

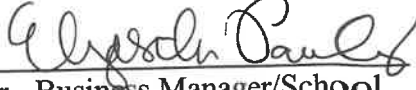
Authorized Signature:   
Department Head/City or Business Manager/School

NAME: Manene Hunt

**CALCULATION**

VACATION DAYS # \_\_\_\_\_ @ \$ \_\_\_\_\_ = \$ \_\_\_\_\_

SICK DAYS # 76.50 @ \$ 471.41 = \$ 36,062.87 ✓

PRO-RATED STIPENDS # \_\_\_\_\_ @ \$ \_\_\_\_\_ = \$ \_\_\_\_\_

OTHER # \_\_\_\_\_ @ \$ \_\_\_\_\_ = \$ \_\_\_\_\_

**Total Amount Due:** \$ 36,062.87  
Please attach corresponding PAF or other backup to this sheet.

**Reason:** retirement

**For Human Resources's Use Only:**

- VACATION DAYS
- SICK DAYS
- PER ACCRUAL REPORT
- OTHER

**Org and Object:** 83113 - 5146

**Recommendation:**   
 Approved

\_\_\_\_\_  
H R Director/City or Superintendent/Schools





# Employee Master [CITY OF SALEM, MA - LIVE]

BG

Close | 
 Search | 
 Add | 
 Update | 
 Delete | 
 Output | 
 Print | 
 Display | 
 PDF | 
 Save | 
 Email | 
 Schedule | 
 Attach | 
 Detail

## Employee Master [CITY OF SALEM, MA - LIVE]

### Employee Identification

Employee \* 500248      SSN \*      Last Name \* LUNT      First Name \* MARLENE      Middle Name  
 Preferred Name

**Main**      **Dates**      **Demographics**      **Address**      **Payroll**      **Mail Sort**      **Last Change**      **User Defined**

### Dates

Inactive 01/13/2023      Code RET - RETIREMENT  
 Terminated      Code

Birth \* 01/08/1956  
 Hired 11/21/1994  
 Service 01/01/1994  
 Permanent 11/21/1994  
 Orig Hire 01/01/1994

Ret/Pension  
 Probation

# Employee Accruals [CITY OF SALEM, MA - LIVE]

AB

Close |  Accept |  Search |  Browse |  Add |  Update |  Delete |  Output |  Print |  Display |  PDF |  Save |  Excel |  Word |  Email |  Sch

## Employee Accruals [CITY OF SALEM, MA - LIVE]

### Employee Identification

Employee \*  SSN  Last Name  First Name  MI  Suffix

### Employee Accrual Information

Location	5080 - SCHOOL - WITCHCRAFT SCHOOL	SOY Balance	70.5000
Group/BU	5002 - TEACHERS 1258	Earned YTD	7.5000
Job Class *	5198 - CITY CONNECT ADJ COUNSELOR	Used YTD	1.5000
Type *	1 - SICK	Available	76.5000
Table *	502 - TEACHERS SICK ACCRUAL		

Send Accrual Threshold Alert

Active

Accr Date *	<input type="text" value="01/01/2023"/>	Pending	<input type="text" value="0.0000"/>
Start Date *	<input type="text" value="06/30/2014"/>	Liability	<input type="text" value="36062.93"/>
End Date *	<input type="text" value="12/31/9999"/>	UOM	<input type="text" value="D"/>
Default Limit	<input type="text" value="0.00"/>	Default Rate	<input type="text" value="1.5000"/>
Actual Limit	<input type="text" value="0.00"/>	Actual Rate	<input type="text" value="0.0000"/>

The parties shall memorialize these leadership stipends annually for MTRS purposes.

- a. Head Teachers for Physical Education, Fine and Performing Arts, and World Languages, as well as the Music Coordinator, will be responsible for participating in the delivery of four (4) 2-hour PD sessions during release days for K-12 teachers. For this responsibility, their annual head teacher stipend will be increased to four thousand five hundred (\$4,500.00).
3. **Stipends for Bilingualism/Biliteracy:** Active employees and new employees who are certified or deemed to be bilingual/biliterate via employer approved certification process and/or test shall receive an annual stipend of one thousand dollar (\$1,000.00). The expectation is that employees that receive this stipend will support building-based and district wide multilingual communication needs.

#### **O. Methods of Salary Payment**

Salaries shall be paid in twenty-six equal installments beginning on the Friday nearest to September 15 and continuing on every other Friday thereafter. Personnel desiring a lump-sum payment of money at the end of June may receive all accumulated monies by notifying the Superintendent by May 1.

Members of the Bargaining Unit may choose to receive their salaries in twenty-one equal paychecks. Personnel selecting such option must do so by September 1 in any year. Said election shall remain in effect for the remainder of the year and from year to year thereafter unless notice is made as set forth above.

Yearlong stipends shall be paid in two (2) installments during the months of December and June, if possible in a separate check from the bi-weekly payroll check. Seasonal stipends shall be paid, during the month of December for fall activities and during the month of June for winter and spring activities, if possible in a separate check from the bi-weekly payroll check.

#### **P. Severance Pay/Sick Leave Buyback**

1. **Severance Pay:** On the retirement or death of a teacher who has been continuously employed prior to September 1, 2000, payment for accumulated sick leave will be made to the teacher or his/her estate up to a total of eighty (80) days. On the retirement or death of a teacher who has been employed on or after September 1, 2000, payment for accumulated sick leave will be made to the teacher or his/her estate up to a total of forty (40) days. Effective January 1, 2013, employees hired on or after this date shall not be eligible for any severance pay as described above.

To be eligible for this payment, retiring teachers must provide the Superintendent with sixty (60) days advance notice of said retirement, except in emergency situations. For the purpose of this section, the word "retirement" is defined as being an employee who is eligible for and receiving benefits in accordance with the rules and regulations of the



Nancy Weiss &lt;nweiss@salemk12.org&gt;

**Fwd: Marlene Lunt: Letter of Intent**

1 message

Mon, Oct 31, 2022 at 8:36 AM

**Brenna Gloudemans** <bgloudemans@salemk12.org>  
 To: Jill Conrad <jconrad@salemk12.org>, Nancy Weiss <nweiss@salemk12.org>

Brenna Gloudemans | Payroll Coordinator  
 She/Her/Hers

Salem Public Schools  
 Collins Middle School Business Office Room 133  
 29 Highland Avenue  
 Salem, MA 01970  
 978.740.1226 X60516 (O) 978.740.1152 (F)  
 bgloudemans@salemk12.org

----- Forwarded message -----

From: <tjam93@aol.com>  
 Date: Sun, Oct 30, 2022 at 9:32 PM  
 Subject: Marlene Lunt: Letter of Intent  
 To: szrike@salemk12.org <szrike@salemk12.org>  
 Cc: scarmona@salemk12.org <scarmona@salemk12.org>, mriccio@salemk12.org <mriccio@salemk12.org>, bgloudemans@salemk12.org <bgloudemans@salemk12.org>, kmarino@salemk12.org <kmarino@salemk12.org>, lrichard@salemk12.org <lrichard@salemk12.org>

October 26, 2022

Dear Superintendent Dr. Stephen Zrike,

It is with much sadness that I write this letter of my intent to retire early in January of 2023.

The past few years have been difficult for all of us, to say the least. I had hoped and planned to continue my work here for another school year or two, doing the work I so love, before I retired. But due to the unfortunate circumstances of my husband's health, I am needed at home. This has not been an easy decision.

I have had the great honor to work with some of the best educators here at Salem Public Schools. The connections I've made, the friends and colleagues I have learned from, will be an experience I will hold forever in my heart. I am grateful to be ending my career here in Salem. I will take with me some great memories and experiences.

I have enjoyed my many years work at Salem Public schools, I've put my two children through school here and my two grandchildren now attend Witchcraft Heights Elementary School. I've fought over the years to make Salem Schools a better place for our children, our community and our educators. And as I leave, I leave with pride and gratitude.

My intended date of retirement is January 27, 2023

10/31/22, 9:12 AM

Salem Public Schools Mail - Fwd: Marlene Lunt: Letter of Intent

I hope that my love for the children of Salem, the experiences I've had here, have made a difference in the lives of those in this community and I hope you will consider me in the future if there are any part-time opportunities that allow me to continue the hard work I love, on a smaller scale.

With Sincerity and Much Appreciation,

Marlene A. Lunt, LCSW, Ed.M.  
6 Greenway Road  
Salem, MA 01970  
978-618-5641 [tjam93@aol.com](mailto:tjam93@aol.com)

[tjam93@aol.com](mailto:tjam93@aol.com)



**ROBERT K. McCARTHY**  
ACTING MAYOR

LISA B. CAMMARATA  
DIRECTOR OF HUMAN RESOURCES

**CITY OF SALEM MASSACHUSETTS**  
HUMAN RESOURCES  
98 WASHINGTON STREET, 3<sup>RD</sup> FLOOR  
SALEM, MASSACHUSETTS 01970  
TEL. 978-619-5630

**MEMORANDUM**

**TO:** Anna Freedman, Director of Finance  
**DATE:** March 3, 2023  
**RE:** Retirement Stabilization Fund

\*\*\*\*\*

Attached you will find a retirement buyback for a former employee of the Salem Public Schools.

This former employee is entitled to the following amount of sick leave buyback.

**Lauri Panneton**

23.75 sick days @ \$445.92 per day	<b>\$10,590.60</b>
<b>Total:</b>	<b>\$10,590.60</b>

In accordance with the July 2008 Policy, I am requesting you verify the availability of the funds from the Retirement Stabilization Fund, prepare the Council Order, and continue the process in order that my staff can input the information in MUNIS and issue payments to this former employee upon Council approval.

Thank you for your cooperation, and if you should have any questions, please do not hesitate to contact me.

**CITY OF SALEM**  
**APPROVAL-SICK DAYS/VACATION BUY-BACK**

From: Department School

Date 2/24/23

Authorized Signature: [Signature]  
Department Head/City or Business Manager/School

NAME: Lauri Panneton

**CALCULATION**

VACATION DAYS # \_\_\_\_\_ @ \$ \_\_\_\_\_ = \$ \_\_\_\_\_

SICK DAYS # 23.75 @ \$ 445.92 = \$ 10,590.60 ✓

PRO-RATED STIPENDS # \_\_\_\_\_ @ \$ \_\_\_\_\_ = \$ \_\_\_\_\_

OTHER # \_\_\_\_\_ @ \$ \_\_\_\_\_ = \$ \_\_\_\_\_

**Total Amount Due:** \$ 10,590.60 ✓  
Please attach corresponding PAF or other backup to this sheet.

Reason: retirement

**For Human Resources's Use Only:**

- VACATION DAYS
- SICK DAYS
- PER ACCRUAL REPORT
- OTHER

Org and Object: 83/13 - 5/46

**Recommendation:**

Approved

[Signature]  
HR Director/City or Superintendent/Schools

# Employee Accruals [CITY OF SALEM, MA - LIVE]

AB

Employee Master [CITY OF SALEM, MA - LIVE] > Employee Detail > Employee Accruals [CITY OF SALEM, MA - LIVE]

## Employee Identification

Employee \* 
 SSN 
 Last Name 
 First Name 
 MI 
 Suffix

## Employee Accrual Information

Location	5080 - SCHOOL - WITCHCRAFT SCHOOL	SOY Balance	80.7500
Group/BU	5002 - TEACHERS 1258	Earned YTD	7.5000
Job Class *	5202 - GRADE 1 TEACHERS	Used YTD	64.5000
Type *	1 - SICK	Available	23.7500
Table *	502 - TEACHERS SICK ACCRUAL		

Send Accrual Threshold Alert

Active

Accr Date *	<input type="text" value="07/10/2023"/>	Pending	<input type="text" value=".0000"/>
Start Date *	<input type="text" value="06/30/2014"/>	Liability	<input type="text" value="10590.57"/>
End Date *	<input type="text" value="12/31/9999"/>	UOM	<input type="text" value="D"/>
Default Limit	<input type="text" value=".00"/>	Default Rate	<input type="text" value="1.5000"/>
Actual Limit	<input type="text" value=".00"/>	Actual Rate	<input type="text" value="0.0000"/>



# Employee Master [CITY OF SALEM, MA - LIVE]

BG

Close Search Browse Add Update Delete Output Print Display PDF Save Email Schedule Attach Detail

Employee Master [CITY OF SALEM, MA - LIVE]

## Employee Identification

Employee \*      SSN \*      Last Name \*      First Name \*      Middle Name

502083           PANNETON      LAURI

Preferred Name

Main      Dates      Demographics      Address      Payroll      Mail Sort      Last Change      User Defined

### Dates

Inactive	01/31/2023	Code	RET - RETIREMENT
Terminated		Code	

Birth *	11/12/1965
Hired	07/10/2003
Service	07/10/2003
Permanent	07/10/2003
Orig Hire	07/10/2003
Ret/Pension	
Probation	

The parties shall memorialize these leadership stipends annually for MTRS purposes.

- a. Head Teachers for Physical Education, Fine and Performing Arts, and World Languages, as well as the Music Coordinator, will be responsible for participating in the delivery of four (4) 2-hour PD sessions during release days for K-12 teachers. For this responsibility, their annual head teacher stipend will be increased to four thousand five hundred (\$4,500.00).
3. **Stipends for Bilingualism/Biliteracy:** Active employees and new employees who are certified or deemed to be bilingual/biliterate via employer approved certification process and/or test shall receive an annual stipend of one thousand dollar (\$1,000.00). The expectation is that employees that receive this stipend will support building-based and district wide multilingual communication needs.

#### **O. Methods of Salary Payment**

Salaries shall be paid in twenty-six equal installments beginning on the Friday nearest to September 15 and continuing on every other Friday thereafter. Personnel desiring a lump-sum payment of money at the end of June may receive all accumulated monies by notifying the Superintendent by May 1.

Members of the Bargaining Unit may choose to receive their salaries in twenty-one equal paychecks. Personnel selecting such option must do so by September 1 in any year. Said election shall remain in effect for the remainder of the year and from year to year thereafter unless notice is made as set forth above.

Yearlong stipends shall be paid in two (2) installments during the months of December and June, if possible in a separate check from the bi-weekly payroll check. Seasonal stipends shall be paid, during the month of December for fall activities and during the month of June for winter and spring activities, if possible in a separate check from the bi-weekly payroll check.

#### **P. Severance Pay/Sick Leave Buyback**

1. **Severance Pay:** On the retirement or death of a teacher who has been continuously employed prior to September 1, 2000, payment for accumulated sick leave will be made to the teacher or his/her estate up to a total of eighty (80) days. On the retirement or death of a teacher who has been employed on or after September 1, 2000, payment for accumulated sick leave will be made to the teacher or his/her estate up to a total of forty (40) days. Effective January 1, 2013, employees hired on or after this date shall not be eligible for any severance pay as described above.

To be eligible for this payment, retiring teachers must provide the Superintendent with sixty (60) days advance notice of said retirement, except in emergency situations.

For the purpose of this section, the word "retirement" is defined as being an employee who is eligible for and receiving benefits in accordance with the rules and regulations of the

**SALEM PUBLIC SCHOOLS: PAF (PERSONNEL ACTION FORM)**

Employee Name (Last, First) **Panneton, Lauri** Action **6. Termination**  
 Date **1/3/2023** (Payroll Assigns) Employee ID **502083**

**Section 1: New Hire**

**Completed By Hiring Manager**

Job Title (From Posting) **Grade 1 Teacher** School **Witchcraft Height** Posting #   
 Aspen Job Type **Teacher** FTE Status **Full-time** For Hourly Hires: Shift/Schedule   
 Replacement/New Role  Previous Employee or Funding Source  Funding Source   
 Munis Budget Code   
 Names of 3 References   
 (Following Section Only Completed For Staff Needing Professional Licensure)  
 Required certification  Waiver required   
 Beginning MA Educator (1st year working under this license in Mass.)  If yes: Name of Mentor   
 Safety Care Training Required  SEI Endorsement Needed  Is SEI Held?

**Completed By Human Resources**

Start Date  Compensation  Hours Per Day  Shift   
 Column  Step  Annual Salary  Hourly Wage   
 Bargaining Unit  Days Per Year  PTS Start Date  Seniority Date

**Section 2: Wage/Salary Adjustment (HR Only)**

Start Date  Compensation  Hours Per Day  Hourly Wage   
 Column  Step  Annual Salary

**Section 3: Transfer (Completed By Principal or Department Head)**

New Job Title  New Location  Posting #   
 New Job Type  New FTE Status  Schedule Hours   
 Replacement/New Role  Employee Previously In Role  New Budget Code   
 Previous Job Title  Location   
 Job Type  Previous FTE Status

**Section 4: Leave of Absence (HR Only)**

Type of Leave  Start Date  Return to Work

**Section 5: Address/Name Change (Completed by Principal or Department Head)**

New Address   
 New Phone Number   
 New Name

**Section 6: Termination (Completed by Principal or Department Head)**

Reason  Final Work Day  Final Paycheck

**Section 7: Other**

Notes: **Retirement effective 1/31/2023**

**Approvals**

Director or Principal		Date	
Human Resources	Jill Conrad	Date	1/3/2023
Sch. Bus. Administrator		Date	

1/11/23, 2:20 PM

Salem Public Schools Mail - MTRS Paperwork & Sick Leave Buy Back



Brenna Gloudemans <bgloudemans@salemk12.org>

---

## MTRS Paperwork & Sick Leave Buy Back

1 message

Wed, Jan 11, 2023 at 12:01 PM

Lauri Panneton <lpanneton@salemk12.org>  
To: Brenna Gloudemans <bgloudemans@salemk12.org>

Hi Brenna,

I'm checking in to see if my MTRS paperwork is ready for me to pick it up.

I would also like to buy back the remainder of my sick days and would appreciate your input on this process.

Thank you,

Lauri



# CITY OF SALEM

In City Council,

**Ordered:**

March 23, 2023

That the sum of Seventy-Three Thousand, One-Hundred Seventy-Five Dollars (\$73,175.00) is hereby appropriated in the "Retirement Stabilization Fund-Vacation/Sick Leave Buyback" account (83113-5146) to be expended for the sick leave buybacks to be paid out for active employees pursuant to collective bargaining agreements with various unions in accordance with the recommendation of His Honor the Mayor.



**CITY OF SALEM, MASSACHUSETTS**

**Robert K. McCarthy**  
Mayor

March 23, 2023

To the City Council  
City Hall  
Salem, Massachusetts

Ladies and Gentlemen of the Council:

Enclosed herewith is a request for an appropriation of Seventy-Three Thousand, One-Hundred Seventy-Five (\$73,175.00) from the "Retirement Stabilization Fund-Vacation/Sick Leave Buyback" account (83113-5146) to be expended for the sick leave buybacks to be paid out of active employees pursuant to collective bargaining agreements with various unions.

I recommend passage of the accompanying Order.

Very truly yours,

  
Robert K. McCarthy  
Acting Mayor



**ROBERT K. McCARTHY**  
**ACTING MAYOR**

**LISA B. CAMMARATA**  
**DIRECTOR OF HUMAN RESOURCES**

**CITY OF SALEM MASSACHUSETTS**  
**HUMAN RESOURCES**  
**98 WASHINGTON STREET, 3<sup>RD</sup> FLOOR.**  
**SALEM, MASSACHUSETTS 01970**  
**TEL. 978-619-5630**

March 8, 2023

Robert K. McCarthy, Acting Mayor  
City of Salem  
93 Washington Street  
Salem, Massachusetts 01970

**RE: Retirement Stabilization**

Dear Acting Mayor McCarthy:

I am respectfully requesting the amount of \$73,175.00 be appropriated in the Retirement Stabilization Fund for sick leave buybacks submitted in accordance with collective bargaining agreements with our various unions.

Sick leave buyback to be paid out under this appropriation request are for active employees, not retirees, who wish to take advantage of contractual language allowing members to buy back certain amounts of unused sick leave, on an annual basis. A lump sum request for this purpose will allow us to process those requests.

A breakdown by bargaining unit is as follows:

Patrolman's Union:	\$31,000.00
Superior Officer's Union:	\$ 3,500.00
Salem Teachers Union and Para Union:	\$31,175.00
Salem Firefighter's Union:	\$7,500.00

Thank you for your attention and cooperation with this request, and if you have any questions, please do not hesitate to contact me.

Very truly yours,

  
Lisa B. Cammarata



# CITY OF SALEM

In City Council,

**Ordered:**

March 23, 2023

To accept the donation of One Thousand Two Hundred Dollars (\$1,200.00) from Helen Abraham. The donation is to be deposited into the Parks and Recreation Donation Fund 2406 (24061-4830) for a standard cardinal bench in accordance with the recommendation of His Honor the Mayor.





## CITY OF SALEM, MASSACHUSETTS

Robert McCarthy  
Mayor

March 23, 2023

Honorable Salem City Council  
Salem City Hall  
Salem, Massachusetts 01970

Ladies and Gentlemen of the City Council:

Enclosed herewith is a request to accept a donation of One Thousand Two Hundred Dollars (\$1,200.00) from Helen Abraham to purchase a standard cardinal bench. These funds will be deposited into the Parks and Recreation Donation Fund 24061-4830.

In order to accept the donation, approval must be given by both the Mayor and City Council. I ask that the members of the City Council join with me in accepting these funds to be used to support the Parks and Recreation Donation Fund.

Very truly yours,

  
Robert K. McCarthy  
Acting Mayor



Robert McCarthy  
ACTING MAYOR

## CITY OF SALEM, MASSACHUSETTS

PARK, RECREATION & COMMUNITY SERVICES

401 Bridge Street, Salem MA 01970

Tel. (978) 744-0180/ (978) 744-0924

Fax (978) 744-7225

[PObrien@salem.com](mailto:PObrien@salem.com)

Trish O'Brien  
SUPERINTENDENT

March 8, 2023

Dear Acting Mayor McCarthy:

I am writing to request the acceptance of a \$1,200.00 donation written to the City of Salem for a Standard Cardinal Bench from Helen Abraham. To be deposited into Park & Recreation Donation account #24061-4830.

Sincerely,

A handwritten signature in black ink, appearing to read "Tricia O'Brien", written over a horizontal line.

Tricia O'Brien  
Superintendent, City of Salem  
Jean A. Levesque Community Life Center  
(Park, Recreation & Community Services)



# CITY OF SALEM

In City Council,

March 23, 2023

**Ordered:**

To accept the donation of One Thousand Two Hundred Dollars (\$1,200.00) from Marion Rudolph. The donation is to be deposited into the Parks and Recreation Donation Fund 2406 (24061-4830) for a standard cardinal bench in accordance with the recommendation of His Honor the Mayor



## **CITY OF SALEM, MASSACHUSETTS**

**Robert McCarthy  
Mayor**

March 23, 2023

Honorable Salem City Council  
Salem City Hall  
Salem, Massachusetts 01970

Ladies and Gentlemen of the City Council:

Enclosed herewith is a request to accept a donation of One Thousand Two Hundred Dollars (\$1,200.00) from Marion Rudolph to purchase a standard cardinal bench. These funds will be deposited into the Parks and Recreation Donation Fund 24061-4830.

In order to accept the donation, approval must be given by both the Mayor and City Council. I ask that the members of the City Council join with me in accepting these funds to be used to support the Parks and Recreation Donation Fund.

Very truly yours,

Sincerely,

A handwritten signature in cursive script, appearing to read "Robert K. McCarthy".

**Robert K. McCarthy  
Acting Mayor**



Robert McCarthy  
ACTING MAYOR

**CITY OF SALEM, MASSACHUSETTS**  
**PARK, RECREATION & COMMUNITY SERVICES**

401 Bridge Street, Salem MA 01970  
Tel. (978) 744-0180/ (978) 744-0924  
Fax (978) 744-7225  
[PObrien@salem.com](mailto:PObrien@salem.com)

Trish O'Brien  
SUPERINTENDENT

March 8, 2023

Dear Acting Mayor McCarthy:

I am writing to request the acceptance of a \$1,200.00 donation written to the City of Salem for a Standard Cardinal Bench from Marion Rudolph. To be deposited into Park & Recreation Donation account #24061-4830.

Sincerely,

A handwritten signature in black ink, appearing to read "Tricia O'Brien".

Tricia O'Brien  
Superintendent, City of Salem  
Jean A. Levesque Community Life Center  
(Park, Recreation & Community Services)



# CITY OF SALEM

In City Council,

March 23, 2023

**Ordered:**

To accept the donation of One Thousand Dollars (\$1,000.00) from Giovanni Alabiso. The donation is to be deposited into the Planning Donation Fund 2407 (24071-4830) to commission a bronze statue of Charlotte Forten to be installed at 289 Derby Street in accordance with the recommendation of His Honor the Mayor.



**CITY OF SALEM, MASSACHUSETTS**  
**Robert K. McCarthy**  
**Mayor**

March 23, 2023

Honorable Salem City Council  
Salem City Hall  
Salem, Massachusetts 01970

Ladies and Gentlemen of the City Council:

Enclosed herewith is a request to accept the donation of One Thousand Dollars (\$1,000.00) to be deposited into the Planning Donation Fund 2407 (24071-4830) to commission a bronze statue of Charlotte Forten to be installed at 289 Derby Street.

In order to accept the donations approval must be given by both the Mayor and City Council. I ask that the members of the City Council join with me in accepting this donation for the Planning Department Fund.

Very truly yours,

A handwritten signature in cursive script, appearing to read "Robert K. McCarthy".

Robert K. McCarthy  
Mayor



**CITY OF SALEM, MASSACHUSETTS**  
**DEPARTMENT OF PLANNING AND**  
**COMMUNITY DEVELOPMENT**

---

98 WASHINGTON STREET, 2<sup>ND</sup> FLOOR ♦ SALEM, MASSACHUSETTS 01970  
978-619-5685

March 16, 2023

Mayor Robert McCarthy  
Salem City Hall  
93 Washington Street  
Salem, MA 01970

RE: Acceptance of Donation for Charlotte Forten Memorial Project

Dear Mayor McCarthy:

This letter is to request acceptance of a one thousand dollar (\$1,000) donation from Salem Historical Tours' owner, Giovanni Alabiso.

This donation will support the City's Charlotte Forten Memorial Project, an on-going public art initiative to commission a bronze statue of Charlotte Forten to be installed at 289 Derby Street.

Please let me know if you have any questions.

Sincerely,

Tom Daniel, AICP  
Director  
Planning & Community Development





**CITY OF SALEM, MASSACHUSETTS**

Robert K. McCarthy

Mayor

**PROCLAMATION**  
**CITY OF SALEM - MAYORAL PROCLAMATION**

***2023 Motorcycle Safety Awareness Period***

- WHEREAS,** the motorcycle is a popular means of transportation for commuting, as well as for touring and recreation; and
- WHEREAS,** there is a growing need for cooperation among drivers of automobiles and trucks, motorcyclists, bicyclists, and pedestrians who use our streets and highways - *to reduce accidents, injuries, and fatalities;* and
- WHEREAS,** it is critical for all Massachusetts citizens to increase their knowledge of the rules of the road and the rights and responsibilities of all roadway users; and
- WHEREAS,** over 650\* motorcycles are owned and operated by our fellow citizen-bikers, homeowners and residents of **Salem** and the tens of thousands more visiting and touring our historic City from neighboring communities and the entire United States and from overseas, and
- WHEREAS,** numerous Departments and organizations are committed to making our streets and highways safe for all motor vehicle-related transportation, urging and reminding drivers to - "Check Twice - Save a Life, Motorcycles are Everywhere"- "Check Twice" when pulling out and backing out from parked positions; "Check Twice" when making left turns; "Check Twice" when changing traffic lanes; "Check Twice" for our fellow citizen-bikers of Amesbury and visitors to our City on motorcycles,

**NOW, THEREFORE, I, Robert K. McCarthy,** as Acting Mayor, City of Salem, Massachusetts, do hereby join with the Governor of the Commonwealth of Massachusetts, and all agencies and organizations, **do hereby**

**PROCLAIM March 25th to April 30, 2023, to be, our:**

***MOTORCYCLE SAFETY AWARENESS PERIOD*** here in our City of Salem  
**AND** wish all who ride, an enjoyable and safe riding season.

**WITNESS MY HAND AND THE OFFICIAL  
SEAL OF THE CITY OF SALEM  
THIS 21 DAY OF MARCH, 2022**

Robert K. McCarthy  
Acting Mayor



## **CITY OF SALEM, MASSACHUSETTS**

Robert K. McCarthy  
Acting Mayor

### **INFORMATION ONLY**

March 21, 2023

Honorable Salem City Council  
Salem City Hall  
Salem, Massachusetts 01970

Ladies and Gentlemen of the City Council:

Acting Mayor McCarthy is pleased to share that he has signed through signature a mayoral proclamation that March 25<sup>th</sup> to April 30, 2023 to be "Motorcycle Safety Awareness Period" here in our City of Salem. We wish all who ride and enjoyable and safe riding season, as we have over 650+ motorcycles in our city alone and motorcycle accidents continue rise.

We join the Governor of the Commonwealth in sharing this proclamation and invite you to draw any attention to this cause as you deem appropriate.

Sincerely,

A handwritten signature in black ink, appearing to read "Robert K. McCarthy", is written over a horizontal line.

Robert K. McCarthy,  
Acting Mayor

# The Commonwealth of Massachusetts



## A Proclamation

*Whereas, The motorcycle is a popular means of transportation for commuting, as well as for touring and recreation; and*

*Whereas, There is a growing need for cooperation among drivers of automobiles and trucks, motorcyclists, bicyclists and pedestrians who use our streets and highways to reduce injuries and fatalities; and*

*Whereas, It is critical for all Massachusetts citizens to increase their knowledge of the rules of the road and the rights and responsibilities of all roadway users; and*

*Whereas, Numerous organizations are committed to making our streets and highways safe for all motor vehicle-related transportation, including the Highway Safety Division, the Massachusetts Rider Education Program, the Registry of Motor Vehicles, the American Motorcyclists Association, the Motorcycle Safety Foundation, the Massachusetts Motorcycle Association, and many motorcycle businesses and clubs in the Commonwealth,*

*Now, Therefore, I, Maura T. Healey, Governor of the Commonwealth of Massachusetts, do hereby proclaim March 25<sup>th</sup> to April 30<sup>th</sup>, 2023 to be,*

## MOTORCYCLE SAFETY AWARENESS PERIOD

*And urge all the citizens of the Commonwealth to take cognizance of this event and participate fittingly in its observance.*

*Given at the Executive Chamber in Boston, this first day of March, in the year two thousand and twenty-three, and of the Independence of the United States of America, the two hundred and forty-sixth.*

BY HER EXCELLENCY

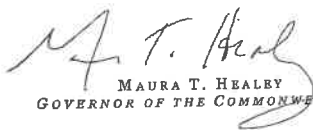
  
MAURA T. HEALEY  
GOVERNOR OF THE COMMONWEALTH

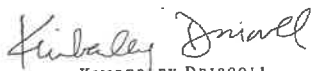
  
KIMBERLEY DRISCOLL  
LT. GOVERNOR OF THE COMMONWEALTH

  
WILLIAM FRANCIS GALVIN  
SECRETARY OF THE COMMONWEALTH

*God Save the Commonwealth of Massachusetts*



## **CITY OF SALEM, MASSACHUSETTS**

Robert K. McCarthy  
Acting Mayor

### **INFORMATION ONLY**

March 21, 2023

Honorable Salem City Council  
Salem City Hall  
Salem, Massachusetts 01970

Ladies and Gentlemen of the City Council:

Acting Mayor McCarthy is pleased to report through David Kucharsky, Director of Traffic and Parking, that the City of Salem has been awarded a set of combination radar feedback equipment and school zone speed limit sign assemblies. This MOA was signed on Tuesday, March 21, 2023 and will follow next steps with the legal department to ensure all matters are finalized appropriately.

The MassDOT indicates that the speed-calming assemblies are offered in response to an increase in speed-related traffic deaths and injuries in Massachusetts, as well as a recent revision to the Manual on Uniform Traffic Control Devices that now defines school zones to include grades 9 through 12. Up to 50 municipalities were chosen, including Salem, to receive two assemblies to support one school zone area, with awardees selected based on need, context, environment, risks and crash history.

For any other follow-up questions, please follow up with David Kucharsky, Director of Traffic and Parking.

Sincerely,

A handwritten signature in black ink, appearing to read "Robert K. McCarthy", written over a horizontal line.

Robert K. McCarthy  
Acting Mayor

## MEMORANDUM OF AGREEMENT

This Memorandum of Agreement (“MOA”) is made and entered into this \_\_\_\_ day of March, 2023 by and between the Massachusetts Department of Transportation, having offices at 10 Park Plaza, Boston, Massachusetts 02116 (“MassDOT”), and the City/Town of \_\_\_\_\_, a municipal corporation within the Commonwealth of Massachusetts, having offices at \_\_\_\_\_ (“Municipality”). MassDOT and the Municipality may hereafter be collectively referred to herein as the “Parties” and individually as the “Party.”

WHEREAS, MassDOT administers a Federal-Aid grant program that provides Combination Dynamic Speed Feedback and School Zone Speed Sign assemblies (“Speed Feedback Signs” or “Sign Assemblies”) to municipalities for installation in existing municipal school zones to enhance roadway user safety; and

WHEREAS, Municipality has proposed to install Speed Feedback Signs provided by MassDOT at the School(s) in the existing municipal school zone (s) described in Exhibit A, attached hereto, (the “Locations”) in its approved Combination Dynamic Speed Feedback and School Zone Speed Sign Assembly Grant Application; and

WHEREAS, the proposed Locations are within the public right of way in a municipal school zone that conforms with the requirements of Sections 7A.01 and 7A.05 of the 2022 *Massachusetts Amendments to the Manual on Uniform Traffic Control Devices*; and

WHEREAS, Municipality has agreed to install the proposed Speed Feedback Signs at the Locations in accordance with the terms provided herein (the “Project”); and

WHEREAS, MassDOT and Municipality seek to confirm their respective rights and obligations in connection with the Project as set forth in this MOA.

NOW, THEREFORE, in consideration of the obligations contained herein and other good and valuable consideration, the receipt of which is hereby acknowledged, MassDOT and the Municipality hereby agree, each with the other, as follows:

1. **Speed Feedback Signs.** MassDOT will provide Municipality with the Speed Feedback Signs described in Exhibit B, attached hereto. MassDOT will fund the entire cost of the Sign Assemblies, including the cost of delivery to Municipality. Title to the Signs will pass to Municipality upon delivery.

It is understood and agreed that MassDOT’s procurement of the Speed Feedback Signs is contingent upon availability and continued appropriation of federal funds, and if for any reason whatsoever, such funds are terminated or reduced or otherwise become unavailable, MassDOT may terminate this MOA in whole or in part immediately.

2. **Installation.** Municipality, at its sole expense, shall install the Speed Feedback Signs at the aforementioned Location(s). Aside from the Sign Assemblies provided by MassDOT, Municipality shall provide all necessary labor, materials, equipment, and other services necessary to install the Speed Feedback Signs in accordance with vendor specifications. Municipality shall comply with all federal, state, and local laws, ordinances, rules and regulations applicable to the installation of the Sign Assemblies.

Municipality shall install each Speed Feedback Sign in conformance with the requirements of Sections 7B.09 and 2A.19 of the 2009 *Manual of Uniform Traffic Control Devices (MUTCD)*. Prior to installation, Municipality personnel and/or contractors shall attend a training conducted by MassDOT and/or its vendor, free of charge, at a MassDOT District Office to be designated.

Municipality shall also obtain, at its sole cost and expense, any and all applicable permits, approvals, including local approvals, and/or clearances required by local and state agencies, commissions, or bodies necessary for the completion of the Project prior to installing the Speed Feedback Signs. This includes, but is not limited to, any applicable MassDOT Access Permits to enter upon the State Highway. **Nothing contained herein shall be deemed to as permission for Municipality and/or its contractors to enter upon the State Highway for the performance of any activities in connection with the Project, including but not limited to, Municipality's installation, maintenance, repair, and operation obligations as set forth herein, without first obtaining any and all applicable permits.**

Municipality shall install each Sign Assembly within ninety (90) days of its delivery to Municipality. If Municipality cannot complete the installation within the ninety-day period, it may request an extension. Any request for an extension must be made in writing to MassDOT soon as practicably possible, but not later than sixty (60) days after Municipality's receipt of the Sign Assemblies. Municipality's request shall include a justification for the requested extension, the anticipated installation date, and any other information deemed necessary by MassDOT. MassDOT, in its sole and exclusive discretion, may agree to grant said request for an extension of time if it finds that sufficient justification has been provided by the Municipality.

Within a week of installing each Sign Assembly, Municipality shall provide to MassDOT both the latitude and longitude (in decimal degrees (DD) format: e.g. 34.11914, -118.30036) of the installed assembly unit and the serial number or other unique identification number of the unit. This unit identification information must be included when delivering the collected data from each unit pursuant to Section 4 of this MOA.

Within six (6) months of the installation of the Speed Feedback Signs, Municipality shall

provide a brief written report to MassDOT describing Municipality's experiences [training, installation, data collection, associated costs (including without limitation time spent) and benefits and any unintended consequences both positive and negative]. This report is separate from the data reporting requirements in Section 4.

3. **Operation and Maintenance.** Municipality, at its sole cost, shall be solely responsible for the operation, maintenance, repair, and disposal at the end of service life, and other handling of the Speed Feedback Signs. The Speed Feedback Signs shall be designated, located, and operated in accordance with the Standards of MassDOT for such devices. The Police Department of Municipality shall be the enforcement agency for traffic regulations established in accordance with the with this MOA and the Speed Feedback Signs installed in connection therewith.

Municipality, in accordance with the provisions of Sections 109(d) and 116 of Title 23 USC, shall properly maintain the way and all Speed Feedback Signs and under the control of Municipality within the Project area. This obligation includes features of facilities and equipment that are required to be readily accessible to and usable by persons with disabilities. This requirement does not prohibit isolated or temporary interruptions in service or access due to maintenance or repairs. Municipality's obligations under this Section 3 shall survive the expiration of this MOA.

4. **Data.** Municipality shall electronically deliver to MassDOT all data gathered from the Signs (1) during the first thirty (30) day period immediately following the Signs' installation and (2) at any other such time as may be requested by MassDOT until January 1, 2026. Such data will be delivered to MassDOT in a form and manner acceptable to MassDOT (including without limitation in accordance with any information security protocols designated by MassDOT, if applicable). Municipality's obligations under this Section 4 shall survive the expiration of this MOA.
5. **Term.** This MOA shall be effective as of the date of full execution by Municipality and MassDOT and, unless terminated earlier as provided herein or otherwise agreed in writing by the Parties, shall remain in full force and effect for a period of two (2) years after Municipality's receipt of the Sign Assemblies. This MOA may be terminated by mutual agreement of the Parties, upon such terms and conditions as the Parties may mutually agree upon. Such termination shall be effective in accordance with a written agreement by the Parties.

In addition, MassDOT may, by written notice to Municipality, terminate this MOA in any one of the following circumstances:

- (a) The Municipality neglects or fails to comply with any provision of this MOA in

accordance with its terms or within the time specified for performance herein, and Municipality fails to cure any such failure within thirty (30) calendar days after receipt of notice specifying such failure. In the event this MOA is terminated pursuant to this provision, MassDOT shall not be liable to the Municipality for any costs incurred or burdens assumed upon or subsequent to, and associated with, such termination.

- (b) The applicable Federal funding source fails to appropriate or otherwise make available funds for the Signs. In the event this Agreement is terminated pursuant to this provision, MassDOT shall not be liable to Municipality for any costs.

In the event that MassDOT terminates this MOA subsequent to the delivery of the Sign Assembly to Municipality but prior to its installation, Municipality shall, at its expense, return the Sign Assembly to the applicable MassDOT District Office.

6. **Compliance with Laws.** Municipality, in meeting its obligations hereunder, shall comply with all applicable federal, state, county, municipal and other governmental statutes, laws, rules, orders, regulations and ordinances. Municipality's obligations under this Section 6 shall survive the expiration of this MOA.
7. **Indemnification.** To the extent permitted by the laws of the Commonwealth, Municipality shall indemnify, defend (at Municipality's sole expense and with counsel reasonably acceptable to MassDOT), and hold harmless MassDOT and all of MassDOT's officers, agents, and employees, from and against any and all suits, claims, proceedings, liabilities, losses damages, penalties, charges and expenses (including attorneys' fees and experts' fees) of every name and nature, based on or arising out of any actual or alleged loss or injury (including death) to persons or damage to real or tangible property that are caused or alleged to be caused, in whole or in part, by, or to arise out of the acts or omissions of, Municipality, or its employees, contractors, subcontractors, or agents, in its performance of the obligations set forth herein. Municipality's obligations under this Section 7 shall survive the expiration or earlier termination of this MOA.
8. **Notices:** Any notices required or permitted to be given hereunder shall be given in writing and shall be delivered (a) in person, (b) by certified or registered mail, postage prepaid, return receipt requested, or (c) by a commercial overnight courier that guarantees next day delivery and provides a receipt. Such notices shall be addressed as follows:

MASSDOT:

James V. Terlizzi, P.E.  
MassDOT Traffic & Safety  
10 Park Plaza, Room 7520  
Boston, MA 02116



The MUNICIPALITY:

---

---

---

---

or to such other address as either Party may from time to time specify in writing to the other Party. Any notice shall be effective only upon delivery.

9. **Authority.** The individuals executing this MOA represent that they are empowered and duly authorized to so execute this MOA on behalf of the Parties they represent.
10. **Miscellaneous.** This MOA represents the entire agreement between the Parties with respect to the subject matter hereof, superseding any prior oral or written agreements or understandings regarding the same, and any modification amendment or change to the terms and conditions hereof shall be binding only when expressed in writing and signed by both Parties hereto. This MOA may be signed in multiple counterparts each of which shall be deemed an original, but all of which when taken together shall constitute one and the same instrument. This MOA shall be governed by and interpreted in accordance with the laws of the Commonwealth of Massachusetts, without regard to its choice of law rules. If any provision or condition of this MOA shall be deemed invalid or unenforceable, the remaining provisions and conditions shall remain in full force and effect and shall be valid and enforceable to the fullest extent permitted by law.

[Remainder of page intentionally blank]

IN WITNESS WHEREOF, the Parties have executed this MOA as an instrument under seal as of the date last written below.

MASSACHUSETTS DEPARTMENT OF  
TRANSPORTATION

By: \_\_\_\_\_

Name:

Title:

MUNICIPALITY

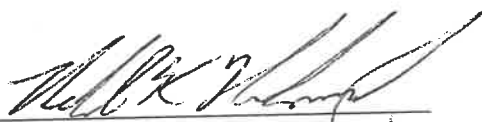
By:  \_\_\_\_\_

Name: Robert K. McCarty

Title: Acting Mayor

# EXHIBIT A

## COMBINATION DYNAMIC SPEED FEEDBACK SIGN AND SCHOOL ZONE LOCATIONS

1. \_\_\_\_\_ School in the existing municipal school zone at the following streets(s): \_\_\_\_\_

## **EXHIBIT B**

**COMBINATION DYNAMIC SPEED FEEDBACK AND SCHOOL ZONE SPEED LIMIT  
SIGN ASSEMBLY DESCRIPTION**

SOLAR PANEL ORIENTED FOR OPTIMAL SUNLIGHT CAPTURE

12" YELLOW BEACON W/ 5" BACKPLATE

7"

SCHOOL SPEED LIMIT 20 WHEN FLASHING

YOUR SPEED 20

TRAFFIC SIGNAL POST & PEDESTAL

7"(MIN)

SIDEWALK

TRAVEL WAY

CURB

CEMENT CONCRETE FOUNDATION

**NOTES:**

1. REFER TO THE SPECIAL PROVISIONS FOR SIGN DIMENSIONS. THE NEMA ENCLOSURE SHALL BE POLE-MOUNTED. THE ENCLOSURE SHALL BE PLACED IN A MANNER WHERE IT WOULD NOT CONSTITUTE A PROTRUDING OBJECT UNDER ADA/AAB REQUIREMENTS

**MAJOR ITEMS LIST**

- 1 CEMENT CONCRETE FOUNDATION PER 812.30.1
- 1 TRAFFIC SIGNAL POST AND PEDESTAL
- 1 CIRCULAR YELLOW BEACON
- 1 S5-1 SIGN
- 1 SPEED FEEDBACK CHANGEABLE MESSAGE SIGN
- 1 RADAR UNIT
- 1 SOLAR PANEL SYSTEM
- 1 NEMA ENCLOSURE FOR ALL COMPONENTS NEEDED TO MEET FUNCTIONAL REQUIREMENTS PER SPECIAL PROVISIONS

PLUS ALL MOUNTING AND SUPPORTING HARDWARE AND WIRING NECESSARY TO COMPLETE A WORKING SYSTEM.



## CITY OF SALEM, MASSACHUSETTS

Robert K. McCarthy  
Acting Mayor

### INFORMATION ONLY

March 20, 2023

Honorable Salem City Council  
Salem City Hall  
Salem, Massachusetts 01970

Ladies and Gentlemen of the City Council:

As tradition has dictated in previous years, we are sharing information relative to the Salem High School's Senior Program, with the 20<sup>th</sup> After Prom Party returning after a three-year disruption.

As shared by Principal Glenn Burns to the Mayor's Office, the Salem High School Post Prom Party is asking those who can contribute to please contact Donna Fritz, After Prom Committee Chair at 978-828-5673 or [donnafriz44@gmail.com](mailto:donnafriz44@gmail.com). Additionally, there is an official GoFundMe page which features the following language:

"For prom night, parents in our community are organizing an After Prom Party for Salem High School students and guests. The After Prom party will provide students with a chaperoned event that offers fun activities, great prizes, and entertainment in an environment free from drugs and alcohol. This post-prom party is organized by parents & guardians. To make this event possible, we are looking for your support!

By donating today you will help cover the cost of busing 250 students from the prom to the After Prom and back to the high school! Thank you in advance for your contribution. This will go a long way in making sure the Class of 2023 has A NIGHT TO REMEMBER on prom night."

The page can be viewed here: <https://www.gofundme.com/f/salem-high-school-after-prom-party>. This item is being shared to help promote awareness of the charitable request, but this is not an official appeal to the Council nor to the public. All the same, we hope you can draw some attention to this worthy endeavor.

Sincerely,

A handwritten signature in black ink, appearing to read "Robert K. McCarthy".

Robert K. McCarthy  
Acting Mayor



# SALEM HIGH SCHOOL

77 Willson Street • Salem, MA 01970 • 978-740-1123

**Glenn Burns**

*Principal*

gburns@salemk12.org

**Lynne Mullen**

*Assistant Principal, 12th grade*

lmullen@salemk12.org

**Andrew Bub**

*Assistant Principal 11th & 10th grade*

abub@salemk12.org

**Shamus Mruk**

*Assistant Principal 9th grade*

smruk@salemk12.org

February 14, 2023

After Prom Committee  
Salem High School  
77 Willson Street  
Salem, MA 01970

*Thank you for  
Supporting Salem  
High Seniors!  
Donna*

Dear Community Member,

Salem High School's Senior Prom is coming up this spring! In conjunction with the prom, parents in our community are organizing an After Prom Party for Salem High School students at In The Game. This will be Salem High's 20th After Prom Party and we are excited to bring this tradition back to SHS students after a three-year disruption. **To make this year's event possible, we are asking for your support with sponsorship.**

To reduce student risk on this memorable evening, the Salem High School Post Prom Party is intended to provide students with a chaperoned event that offers fun activities, great prizes, and entertainment in an environment free from drugs and alcohol.

This inclusive party is completely funded through donations from individuals, community organizations and businesses. Your monetary contribution will be used to cover event expenses for student prizes, food, beverages and renting In The Game for four hours overnight.

To thank you for your contribution, you or your company will be acknowledged in the school newsletter that goes home to all Salem High Families.

Checks can be made out to SHS After Prom and sent to Salem High School, Attn: After Prom Celebration 2023, 77 Willson Street, Salem MA 01970 or donate to Salem High School After Prom GoFundMe page: <https://www.gofundme.com/f/salem-high-school-after-prom-party>

If you need additional information, please contact Donna Fritz, After Prom Committee Chair at 978-828-5673 or [donnafriz44@gmail.com](mailto:donnafriz44@gmail.com)

Thank You for helping to make prom night SAFE and FUN!

Sincerely,

Glenn Burns and the After Prom Committee

EIN # 046001413



[spsalemhs.salemk12.org](http://spsalemhs.salemk12.org)



@\_SalemHigh\_



@SalemHighSchool.MA

City of Salem

**In the year two thousand and twenty-three**

**An Ordinance** to amend an Ordinance relative to Traffic

*Be it Ordained by the City Council of the City of Salem, as follows:*

**Section 1.** Chapter 42, Section 50B – “Handicap Zone Limited Time” is hereby amended by repealing the following:

Repeal – Summer Street – easterly side, beginning fifty-five (55) feet north of Endicott Street and running in a northerly direction for twenty (20) feet. “Handicap Parking, Limited Time, Tow Zone”

**Section 2.** This Ordinance shall take effect as provided by City Charter.





City of Salem, Massachusetts  
Office of the City Council  
City Hall



**REQUEST FOR TRAFFIC ORDINANCE RECOMMENDATION**

MEMO TO: Lt. David Tucker Police Traffic Division  
FROM: Councilor Watson-Felt DATE: March 20, 2023

In accordance with the Council Rule 32A, I hereby request your recommendation for the following Traffic Ordinance:

NAME OF STREET Summer Street

TYPE OF STREET CHANGE Handicapped Zones, Limited Time

DESCRIPTION OF AREA WHERE CHANGE IS REQUESTED In front of 71 Summer Street.

COUNCILLOR'S COMMENTS/EXPLANATION The disabled resident of 71 Summer Street has moved, and the HP space is no longer needed.

**POLICE TRAFFIC DIVISION RECOMMENDATION**

The Police Traffic Division hereby submits the following recommendation for the above request:

APPROVAL  
 DENIAL  
 TRIAL PERIOD

CHAPTER: 42 SECTION: 50B TITLE: Handicapped Zones, Limited Time

DESCRIPTION: Repeal: Summer Street – easterly side, beginning fifty-five (55) feet north of Endicott Street and running in a northerly direction for twenty (20) feet. (2/19/91)

COMMENTS (IF ANY): \_\_\_\_\_

Lt. David Tucker

POLICE TRAFFIC DIVISION

**RETURN THIS FORM TO THE CITY CLERK'S OFFICE**

City of Salem Clerk's Office, 93 Washington St, Salem Massachusetts 01970

(978) 745-9595 ext 41202 www.salem.com

City of Salem

**In the year two thousand and twenty-three**

**An Ordinance** to amend an Ordinance relative to Traffic

*Be it Ordained by the City Council of the City of Salem, as follows:*

**Section 1.** Chapter 42, Section 50B – “Handicap Zone Limited Time” is hereby amended by adding the following:

Summer Street - in front of #73, for a distance of twenty (20) feet,  
“Handicap Parking, Limited Time, Tow Zone”

**Section 2.** This Ordinance shall take effect as provided by City Charter.



# City of Salem

*In the year Two Thousand and Twenty-Three*

## **An Ordinance Relative to Traffic**

*Be it ordained by the City Council of the City of Salem, as follows:*

**Section 1.** Section 51 of Article V be amended by repealing the following:

Broad Street – Parking Prohibited on Certain Streets - northerly side, beginning at Pickering Street in an easterly direction for thirty (30) feet. (11/13/75 DPW 5-1114)

And inserting the following:

Broad Street – Parking Prohibited on Certain Streets - northerly side, beginning at Pickering Street in an easterly direction for one-hundred and two (102) feet.

**Section 2.** This ordinance shall take effect as provided by City Charter.



City of Salem, Massachusetts  
Office of the City Council  
City Hall



**REQUEST FOR TRAFFIC ORDINANCE RECOMMENDATION**

MEMO TO: Lt. David Tucker Police Traffic Division  
FROM: Councilor Watson-Felt DATE: March 20, 2023

In accordance with the Council Rule 32A, I hereby request your recommendation for the following Traffic Ordinance:

NAME OF STREET Broad Street

TYPE OF STREET CHANGE Parking Prohibited on Certain Streets

DESCRIPTION OF AREA WHERE CHANGE IS REQUESTED Broad Street near Pickering Street.

COUNCILLOR'S COMMENTS/EXPLANATION Change in the distance of the no parking zone, to enhance visibility for traffic and pedestrians, at the intersection of Broad Street and Pickering Street.

**POLICE TRAFFIC DIVISION RECOMMENDATION**

The Police Traffic Division hereby submits the following recommendation for the above request:

- APPROVAL
- DENIAL
- TRIAL PERIOD

CHAPTER: 42 SECTION: 51 TITLE: Parking Prohibited on Certain Streets

DESCRIPTION: **Repeal:** Broad Street – Parking Prohibited on Certain Streets - northerly side, beginning at Pickering Terrace in an easterly direction for thirty (30) feet. (11/13/75 DPW 5-1114) (11/12/15)

**Insert:** Broad Street – Parking Prohibited on Certain Streets - northerly side, beginning at Pickering Street in an easterly direction for one-hundred and two (102) feet.

COMMENTS (IF ANY): \_\_\_\_\_

*Lt. David Tucker*

**POLICE TRAFFIC DIVISION**

**RETURN THIS FORM TO THE CITY CLERK'S OFFICE**

*City of Salem Clerk's Office, 93 Washington St, Salem Massachusetts 01970*

*(978) 745-9595 ext 41202 www.salem.com*

## **Ilene Simons**

---

**From:** David Kucharsky  
**Sent:** Tuesday, March 14, 2023 10:51 AM  
**To:** Ilene Simons  
**Cc:** Patricia Morsillo; Caroline Watson-Felt; David M. Tucker; Chris Sicuranza; Maureen Fisher  
**Subject:** Broad Street Ordinance Amendment  
**Attachments:** Proposed Ordinance Changes - Broad Street.docx

Ilene,

Attached is an ordinance amendment which seeks to restrict parking along a stretch of Broad Street near the intersection with Pickering Street. The change is intended to improve visibility of pedestrians utilizing the crosswalk at this intersection.

David Kucharsky  
Director of Traffic & Parking  
98 Washington Street, 2<sup>nd</sup> Floor  
Salem, MA 01970  
978-619-5697

# City of Salem

---

*In the year Two Thousand and Twenty-Three*

## **An Ordinance Relative to Traffic**

*Be it ordained by the City Council of the City of Salem, as follows:*

**Section 1.** Section 51B of Article V be amended by repealing the following:

Essex Street – Parking Prohibited at Certain Times on Certain Streets - for a distance of one hundred thirty five feet (135) in a westerly direction beginning ninety-five feet (95) from Summer Street, southerly side. Thirty (30) minute parking, 8:00 A.M. to 6:00 P.M. (11/14/94)

Essex Street – Parking Prohibited at Certain Times on Certain Streets - for a distance of one hundred thirty-five (135) feet in a westerly direction beginning ninety-five (95) from Summer Street, southerly side. Thirty (30) minute parking, 8:00 A. M. to 6:00 P. M. (11/14/94)

**Section 2.** Section 56 of Article V be amended by repealing the following:

Essex Street – Parking Meter Zones Established - northerly side, from North Street in a westerly direction to a point opposite the easterly line of Cambridge Street. Four (4) hour parking. (7/20/87) (7/14/11)

**Section 3.** Section 75 of Article V-A be amended by inserting the following:

Essex Street – Parking Prohibitions Towing Zone (Resident Sticker) – Zone C – Color Green – both sides, beginning at Summer Street and continuing in a westerly direction to Cambridge Street. Two (2) hour nonresident parking allowed, Monday through Sunday, 8:00 A.M. to 6:00 P.M. No visitor passes shall be issued for qualifying addresses on this street.

**Section 4.** This ordinance shall take effect as provided by City Charter.

## **Ilene Simons**

---

**From:** David Kucharsky  
**Sent:** Tuesday, March 14, 2023 3:05 PM  
**To:** Ilene Simons  
**Cc:** Chris Sicuranza; David M. Tucker; Maureen Fisher; Caroline Watson-Felt; Christina Hodge  
**Subject:** Essex Street Ordinance Amendment  
**Attachments:** Proposed Ordinance Changes - Essex Street.docx

Ilene,

Attached please find an ordinance amendment which seeks to introduce resident parking on Essex Street from Cambridge St to North/Summer Streets. The amendment also includes 2Hr parking for non-residents Monday-Sunday from 8-6PM.

David Kucharsky  
Director of Traffic & Parking  
98 Washington Street, 2<sup>nd</sup> Floor  
Salem, MA 01970  
978-619-5697





**City of Salem, Massachusetts**  
Office of the City Council  
City Hall



**REQUEST FOR TRAFFIC ORDINANCE RECOMMENDATION**

MEMO TO: Lt. David Tucker Police Traffic Division  
FROM: Councilor Watson-Felt DATE: March 20, 2023

In accordance with the Council Rule 32A, I hereby request your recommendation for the following Traffic Ordinance:

NAME OF STREET Essex Street  
TYPE OF STREET CHANGE Parking Prohibited at Certain Times on Certain Streets  
DESCRIPTION OF AREA WHERE CHANGE IS REQUESTED Essex Street, near Summer Street.  
COUNCILLOR'S COMMENTS/EXPLANATION Repeal of older time limited parking zone language on Essex Street near Summer Street.

**POLICE TRAFFIC DIVISION RECOMMENDATION**

The Police Traffic Division hereby submits the following recommendation for the above request:

XX APPROVAL  
       DENIAL  
       TRIAL PERIOD

CHAPTER: 42 SECTION: 51B TITLE: Parking Prohibited at Certain Times on Certain Streets  
DESCRIPTION: Repeal: Essex Street – Parking Prohibited at Certain Times on Certain Streets - for a distance of one hundred thirty five feet (135) in a westerly direction beginning ninety-five feet (95) from Summer Street, southerly side. Thirty (30) minute parking, 8:00 A.M. to 6:00 P.M. (11/14/94)  
Repeal: Essex Street – Parking Prohibited at Certain Times on Certain Streets - for a distance of one hundred thirty-five (135) feet in a westerly direction beginning ninety-five (95) from Summer Street, southerly side. Thirty (30) minute parking, 8:00 A. M. to 6:00 P. M. (11/14/94)  
COMMENTS (IF ANY): \_\_\_\_\_

POLICE TRAFFIC DIVISION

**RETURN THIS FORM TO THE CITY CLERK'S OFFICE**



**City of Salem, Massachusetts**  
 Office of the City Council  
 City Hall



**REQUEST FOR TRAFFIC ORDINANCE RECOMMENDATION**

MEMO TO: Lt. David Tucker Police Traffic Division  
 FROM: Councilor Watson-Felt DATE: March 20, 2023

In accordance with the Council Rule 32A, I hereby request your recommendation for the following Traffic Ordinance:

NAME OF STREET Essex Street

TYPE OF STREET CHANGE Parking Meter Zones Established

DESCRIPTION OF AREA WHERE CHANGE IS REQUESTED Essex Street, near Summer Street.

COUNCILLOR'S COMMENTS/EXPLANATION Repeal of parking meter zone on Essex Street near Summer Street.

**POLICE TRAFFIC DIVISION RECOMMENDATION**

The Police Traffic Division hereby submits the following recommendation for the above request:

XX APPROVAL  
 \_\_\_\_\_ DENIAL  
 \_\_\_\_\_ TRIAL PERIOD

CHAPTER: 42 SECTION: 56 TITLE: Parking Meter Zones Established

DESCRIPTION: Repeal: Essex Street – Parking Meter Zones Established - northerly side, from North Street in a westerly direction to a point opposite the easterly line of Cambridge Street. Four (4) hour parking. (7/20/87) (7/14/11)

COMMENTS (IF ANY): \_\_\_\_\_

\_\_\_\_\_  
**POLICE TRAFFIC DIVISION**

**RETURN THIS FORM TO THE CITY CLERK'S OFFICE**

*City of Salem Clerk's Office, 93 Washington St, Salem, Massachusetts 01970*

*(978) 745-9595 ext 41202 www.salem.com*



City of Salem, Massachusetts  
Office of the City Council  
City Hall



**REQUEST FOR TRAFFIC ORDINANCE RECOMMENDATION**

MEMO TO: Lt. David Tucker Police Traffic Division  
FROM: Councilor Watson-Felt DATE: March 20, 2023

In accordance with the Council Rule 32A, I hereby request your recommendation for the following Traffic Ordinance:

NAME OF STREET Essex Street

TYPE OF STREET CHANGE Parking Prohibitions Towing Zone (Resident Sticker)

DESCRIPTION OF AREA WHERE CHANGE IS REQUESTED Essex Street, near Summer Street.

COUNCILLOR'S COMMENTS/EXPLANATION Establish a resident sticker and two hour non-resident parking zone. Included in the zone C, color green resident sticker zone.

**POLICE TRAFFIC DIVISION RECOMMENDATION**

The Police Traffic Division hereby submits the following recommendation for the above request:

XX APPROVAL  
       DENIAL  
       TRIAL PERIOD

CHAPTER: 42 SECTION: 75 TITLE: Parking Prohibitions Towing Zone (Resident Sticker)

DESCRIPTION: Essex Street – Parking Prohibitions Towing Zone (Resident Sticker) – Zone C – Color Green – both sides, beginning at Summer Street and continuing in a westerly direction to Cambridge Street. Two (2) hour nonresident parking allowed, Monday through Sunday, 8:00 A.M. to 6:00 P.M. No visitor passes shall be issued for qualifying addresses on this street.

COMMENTS (IF ANY):       

Lt. David Tucker  
POLICE TRAFFIC DIVISION

**RETURN THIS FORM TO THE CITY CLERK'S OFFICE**

City of Salem Clerk's Office, 93 Washington St, Salem Massachusetts 01970

(978) 745-9595 ext 41202 www.salem.com

# City of Salem

*In the year Two Thousand and Twenty-Three*

## **An Ordinance Relative to Traffic**

*Be it ordained by the City Council of the City of Salem, as follows:*

**Section 1.** Section 51 of Article V be amended by repealing the following:

Federal Street – Parking Prohibited on Certain Streets - from North Street to Boston Street, northerly side.

Federal Street – Parking Prohibited on Certain Streets - from North to Flint Street, southerly side. (6/1/53)

Federal Street – Parking Prohibited on Certain Streets - westerly on Federal Street, from Flint Street to No. 172, parking on left side only. (8/14/85 DPW E5-258-2584)

Federal Street – Parking Prohibited on Certain Streets - westerly on Federal Street, from Munroe Street to Flint Street, parking on right side only. (8/14/85 DPW E5-258-2584)

Federal Street – Parking Prohibited on Certain Streets - westerly on Federal Street, from No. 191 to Boston Street, parking on left side only. (10/15/96)

Federal Street – Parking Prohibited on Certain Streets - westerly on Federal Street, from No. 172 to #186 Federal Street, parking on right side only. (10/15/96)

Federal Street – Parking Prohibited on Certain Streets - westerly on Federal Street, from North Street to Beckford, parking on right side only. (8/14/85 DPW E5-258-2584)

Federal Street – Parking Prohibited on Certain Streets - westerly on Federal, from Beckford to Lynn Street, parking on left side only. (1/30/86 DPW E5-258-2655)

And inserting the following:

Federal Street – Parking Prohibited on Certain Streets – southerly side, from intersection with North Street to intersection with Flint Street.

Federal Street – Parking Prohibited on Certain Streets – northerly side, from intersection with Flint Street to western property line of 172 Federal Street.

Federal Street – Parking Prohibited on Certain Streets – southerly side, from eastern property line of 173 Federal Street to western property line of 187 Federal Street.

Federal Street – Parking Prohibited on Certain Streets – northerly side, from eastern property line of 186 Federal to intersection with Boston Street.

**Section 2** Section 51B of Article V be amended by repealing the following:

Federal Street – Parking Prohibited at Certain Times on Certain Streets - southerly side, between the westerly property line of No. 187 Federal Street and Boston Street. Two (2) hour parking 8:00 a. M. to 4:00 P. M. Monday through Friday. (6/6/61 DPW 10684)

**Section 3** Section 74 of Article V be amended by repealing the following:

Federal Street – General Prohibition Towing Zones - northerly side, starting at the intersection of Flint Street in an easterly direction for a distance of sixty feet. (6/23/80 DPW 5-1788)

Federal Street – No Parking, Tow Zone - westerly on Federal Street, from #191 to Boston Street, parking on left side only, right side tow zone. (2/10/11)

Federal Street – Tow Zone, Doctor's Office Only - in front of #76 as marked by signs, One Hour Parking, 9:00 AM to 5:00 PM, Monday through Friday. (9/22/11)

**Section 4.** Section 75 of Article V-A be amended by repealing the following:

Federal Street – Parking Prohibitions Towing Zone (Resident Sticker) – Zone C – Color Green - northerly side, beginning at the easterly side of number 82 federal street and continuing up to flint street (11/10/86)

Federal Street – Parking Prohibitions Towing Zone (Resident Sticker) – Zone C – Color Green - Federal Street from Flint Street to Boston Street, both sides, in a southerly direction, Resident Sticker Parking, Tow Zone (3/22/01)

And inserting the following:

Federal Street - Parking Prohibitions Towing Zone (Resident Sticker) – Zone C – Color Green – in a westerly direction, beginning at the intersection with North Street and continuing to the intersection with Boston Street.

ZONE C COLOR GREEN-#27 North Street to be included to obtain resident sticker parking permits. Only one permit to be issued per dwelling unit, as defined in Section 10 of the City's Zoning Ordinance and no visitor passes shall be issued.

**Section 5.** This ordinance shall take effect as provided by City Charter.

## Ilene Simons

---

**From:** David Kucharsky  
**Sent:** Wednesday, March 15, 2023 10:30 AM  
**To:** Ilene Simons  
**Cc:** Maureen Fisher; Chris Sicuranza; Caroline Watson-Felt; David M. Tucker; Christina Hodge; Brendan Linard  
**Subject:** Federal Street Ordinance Amendments  
**Attachments:** Proposed Ordinance Changes - Federal Between North and Washington.docx; Notice to Council - T&P Commission Action re Federal Wash-North.docx; Proposed Ordinance Changes - Federal Street.docx

Ilene,

Attached are ordinance amendments for the following sections of Federal Street:

- Federal Street Washington to North – In addition to cleaning up older ordinances that are no longer applicable, the amendments seek to convert four metered spaces, which provide overnight resident parking, to full time resident permit parking. These recommendations were presented to the Traffic and Parking Commission last March and were approved unanimously. Summary of the meeting is attached as well as a link to the meeting minutes is provided below.
- Federal Street North to Boston – Additional cleanup of past ordinances as well as extending resident permit parking from 82 Federal to North St. This amendment was discussed with the Ward Councilor and Lt. Tucker to account for the conversion of offices to residences along this stretch of Federal and allow some residents on North St to purchase permits .

[https://www.salemma.gov/sites/g/files/vyhlf7986/f/minutes/meeting\\_minutes\\_march\\_23\\_2022\\_final.pdf](https://www.salemma.gov/sites/g/files/vyhlf7986/f/minutes/meeting_minutes_march_23_2022_final.pdf)

David Kucharsky  
Director of Traffic & Parking  
98 Washington Street, 2<sup>nd</sup> Floor  
Salem, MA 01970  
978-619-5697



**City of Salem, Massachusetts**  
**Traffic and Parking Commission**  
 98 Washington Street, 2<sup>nd</sup> Floor  
 Salem, MA 01970  
[www.salem.com](http://www.salem.com)

Robert McCarthy, Acting Mayor

David Kucharsky, Traffic and Parking Director

**Notice to the City Council of Traffic and Parking Commission Action**

At a meeting of the Salem Traffic and Parking Commission held on March 23, 2022 and attended by:

- Tanya Shallop, Chair
- Eric Papetti, Vice Chair
- Jaime Garmendia
- Jeff Swartz
- Lt. David Tucker

The Commission took the following action:

- Advisory Recommendation
- Ordinance Change Recommendation
  - Handicap Parking
  - Resident Parking
  - Other Change

**Background and notes:** Early in 2022, City staff reviewed the parking conditions on Federal Street between Washington Street and North Street. City staff worked with a consultant to develop a striping plan with the goal of clarifying parking for metered spaces, resident parking and uses associated with adjacent court houses. As part of this effort, staff introduced several recommended ordinance changes to go along with the proposed striping layout. These changes were brought before the Traffic and Parking Commission at the March 23, 2022 meeting. At this meeting, the commissioners reviewed the proposed changes, which adds two additional parking spaces overall and converts some spaces that are currently residential at certain times and metered at other times to be full-time residential spaces. The Commission has recommended the changes be adopted by Council.

**Motion and Vote:** *On a motion duly made by Commissioner Swartz and seconded by Commissioner Tucker, the Traffic and Parking Commission voted to recommend the proposed changes to the traffic ordinance for Federal Street between Washington Street and North Street as proposed by City staff. **The vote is five (5) in favor, and none (0) opposed, the motion passes.***

Vote:

The motion was made by Commissioner Swartz and seconded by Commissioner Tucker.

In Favor:

- Tanya Stepasiuk, Chair
- Eric Papetti, Vice Chair
- Jaime Garmendia
- Jeff Swartz
- Lt. David Tucker

Opposed:

- Tanya Stepasiuk, Chair
- Eric Papetti, Vice Chair
- Jaime Garmendia
- Jeff Swartz
- Lt. David Tucker

Abstained:

- Tanya Stepasiuk, Chair
- Eric Papetti, Vice Chair
- Jaime Garmendia
- Jeff Swartz
- Lt. David Tucker



**City of Salem, Massachusetts**  
Office of the City Council  
City Hall



**REQUEST FOR TRAFFIC ORDINANCE RECOMMENDATION**

MEMO TO: Lt. David Tucker Police Traffic Division  
 FROM: Councilor Watson-Felt DATE: March 20, 2023

In accordance with the Council Rule 32A, I hereby request your recommendation for the following Traffic Ordinance:

NAME OF STREET Federal Street

TYPE OF STREET CHANGE Parking Prohibited on Certain Streets

DESCRIPTION OF AREA WHERE CHANGE IS REQUESTED Federal Street, between North Street and Boston Street.

COUNCILLOR'S COMMENTS/EXPLANATION Repeal of older no parking prohibition zones on Federal Street, replacing with ordinances that reflect what is now in place in that area.

**POLICE TRAFFIC DIVISION RECOMMENDATION**

The Police Traffic Division hereby submits the following recommendation for the above request:

XX APPROVAL

\_\_\_\_\_ DENIAL

\_\_\_\_\_ TRIAL PERIOD

CHAPTER: 42 SECTION: 51 TITLE: Parking Prohibited on Certain Streets

DESCRIPTION: **Repeal:**

Federal Street – Parking Prohibited on Certain Streets - from North Street to Boston Street, northerly side.

Federal Street – Parking Prohibited on Certain Streets - from North to Flint Street, southerly side. (6/1/53)

Federal Street – Parking Prohibited on Certain Streets - westerly on Federal Street, from Flint Street to

No. 172, parking on left side only. (8/14/85 DPW E5-258-2584)

Federal Street – Parking Prohibited on Certain Streets - westerly on Federal Street, from Munroe Street to

Flint Street, parking on right side only. (8/14/85 DPW E5-258-2584)

Federal Street – Parking Prohibited on Certain Streets - westerly on Federal Street, from No. 191 to Boston

Street, parking on left side only. (10/15/96)

Federal Street – Parking Prohibited on Certain Streets - westerly on Federal Street, from No. 172 to #186

Federal Street, parking on right side only. (10/15/96)



Federal Street – Parking Prohibited on Certain Streets - westerly on Federal Street, from North Street to Beckford, parking on right side only. (8/14/85 DPW E5-258-2584)

Federal Street – Parking Prohibited on Certain Streets - westerly on Federal, from Beckford to Lynn Street, parking on left side only. (1/30/86 DPW E5-258-2655)

**Replace with:**

Federal Street – Parking Prohibited on Certain Streets – southerly side, from intersection with North Street to intersection with Flint Street.

Federal Street – Parking Prohibited on Certain Streets – northerly side, from intersection with Flint Street to western property line of 172 Federal Street.

Federal Street – Parking Prohibited on Certain Streets – southerly side, from eastern property line of 173 Federal Street to western property line of 187 Federal Street.

Federal Street – Parking Prohibited on Certain Streets – northerly side, from eastern property line of 186 Federal to intersection with Boston Street.

COMMENTS (IF ANY): \_\_\_\_\_

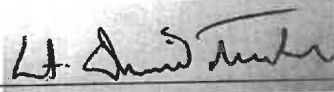

**POLICE TRAFFIC DIVISION**

**RETURN THIS FORM TO THE CITY CLERK'S OFFICE**

*City of Salem Clerk's Office, 93 Washington St, Salem Massachusetts 01970*

*(978) 745-9595 ext 41202 www.salem.com*



City of Salem, Massachusetts  
Office of the City Council  
City Hall



REQUEST FOR TRAFFIC ORDINANCE RECOMMENDATION

MEMO TO: Lt. David Tucker Police Traffic Division  
FROM: Councilor Watson-Felt DATE: March 20, 2023

In accordance with the Council Rule 32A, I hereby request your recommendation for the following Traffic Ordinance:

NAME OF STREET Federal Street

TYPE OF STREET CHANGE Parking Prohibited at Certain Times on Certain Streets

DESCRIPTION OF AREA WHERE CHANGE IS REQUESTED Federal Street, near Boston Street.

COUNCILLOR'S COMMENTS/EXPLANATION Repeal of older no parking prohibition zone on Federal Street, no longer in use.

POLICE TRAFFIC DIVISION RECOMMENDATION

The Police Traffic Division hereby submits the following recommendation for the above request:

APPROVAL

DENIAL

TRIAL PERIOD

CHAPTER: 42 SECTION: 51B TITLE: Parking Prohibited at Certain Times on Certain Streets

DESCRIPTION: **Repeal:** Federal Street – Parking Prohibited at Certain Times on Certain Streets – southerly side, between the westerly property line of No. 187 Federal Street and Boston Street. Two (2) hour parking 8:00 a. M. to 4:00 P. M. Monday through Friday. (6/6/61 DPW 10684)

COMMENTS (IF ANY): \_\_\_\_\_

Lt. David Tucker  
POLICE TRAFFIC DIVISION

RETURN THIS FORM TO THE CITY CLERK'S OFFICE

City of Salem Clerk's Office, 93 Washington St. Salem Massachusetts 01970

(978) 745-9595 ext 41202 www.salem.com



**City of Salem, Massachusetts**  
Office of the City Council  
City Hall



**REQUEST FOR TRAFFIC ORDINANCE RECOMMENDATION**

MEMO TO: Lt. David Tucker Police Traffic Division  
 FROM: Councilor Watson-Felt DATE: March 20, 2023

In accordance with the Council Rule 32A, I hereby request your recommendation for the following Traffic Ordinance:

NAME OF STREET Federal Street  
 TYPE OF STREET CHANGE General Prohibition Towing Zones  
 DESCRIPTION OF AREA WHERE CHANGE IS REQUESTED Federal Street, between North Street and Boston Street.  
 COUNCILLOR'S COMMENTS/EXPLANATION Repeal of older no parking zones on Federal Street that are no longer in use.

**POLICE TRAFFIC DIVISION RECOMMENDATION**

The Police Traffic Division hereby submits the following recommendation for the above request:

XX APPROVAL  
 \_\_\_\_\_ DENIAL  
 \_\_\_\_\_ TRIAL PERIOD

CHAPTER: 42 SECTION: 74 TITLE: General Prohibition Towing Zones  
 DESCRIPTION: Repeal: Federal Street – General Prohibition Towing Zones - northerly side, starting at the intersection of Flint Street in an easterly direction for a distance of sixty feet. (6/23/80 DPW 5-1788)  
Federal Street – No Parking, Tow Zone - westerly on Federal Street, from #191 to Boston Street, parking on left side only, right side tow zone. (2/10/11)  
Federal Street – Tow Zone, Doctor's Office Only - in front of #76 as marked by signs, One Hour Parking, 9:00 AM to 5:00 PM, Monday through Friday. (9/22/11)  
 COMMENTS (IF ANY): \_\_\_\_\_

\_\_\_\_\_

**POLICE TRAFFIC DIVISION**

**RETURN THIS FORM TO THE CITY CLERK'S OFFICE**



City of Salem, Massachusetts  
Office of the City Council  
City Hall



**REQUEST FOR TRAFFIC ORDINANCE RECOMMENDATION**

MEMO TO: Lt. David Tucker Police Traffic Division  
FROM: Councilor Watson-Felt DATE: March 20, 2023

In accordance with the Council Rule 32A, I hereby request your recommendation for the following Traffic Ordinance:

NAME OF STREET Federal Street  
TYPE OF STREET CHANGE Parking Prohibitions Towing Zones (Resident Sticker)  
DESCRIPTION OF AREA WHERE CHANGE IS REQUESTED Federal Street, between North Street and Boston Street.  
COUNCILLOR'S COMMENTS/EXPLANATION Repeal of a resident sticker zone on Federal Street. Part of a clean-up the ordinance language in this area.

**POLICE TRAFFIC DIVISION RECOMMENDATION**

The Police Traffic Division hereby submits the following recommendation for the above request:

APPROVAL  
 DENIAL  
 TRIAL PERIOD

CHAPTER: 42 SECTION: 75 TITLE: Parking Prohibitions Towing Zones (Resident Sticker)  
DESCRIPTION: Repeal: Federal Street – Parking Prohibitions Towing Zone (Resident Sticker) – Zone C – Color Green - northerly side, beginning at the easterly side of number 82 federal street and continuing up to flint street (11/10/86)  
Federal Street – Parking Prohibitions Towing Zone (Resident Sticker) – Zone C – Color Green – Federal Street from Flint Street to Boston Street, both sides, in a southerly direction, Resident Sticker Parking, Tow Zone (3/22/01)  
COMMENTS (IF ANY): \_\_\_\_\_

Lt. David Tucker

**POLICE TRAFFIC DIVISION**

**RETURN THIS FORM TO THE CITY CLERK'S OFFICE**



# City of Salem

*In the year Two Thousand and Twenty-Three*

## **An Ordinance Relative to Traffic**

*Be it ordained by the City Council of the City of Salem, as follows:*

**Section 1.** Section 50A of Article V be amended by inserting the following:

Federal Street – Handicapped Parking Zones – Northerly side, beginning at a point two hundred and thirty (230) feet east of North Street and running in an easterly direction for twenty (20) feet.

**Section 2.** Section 51 of Article V be amended by inserting the following:

Federal Street – Parking Prohibited on Certain Streets – Northerly side, beginning at a point fifty-five (55) feet east of North Street and running in a westerly direction to the intersection with North Street, “No Parking Here to Corner”

**Section 3.** Section 56 of Article V be amended by repealing the following:

Federal Street – Zones Established - southerly side, beginning one hundred and fifty (150) feet from the intersection of Washington Street and Federal Street in a westerly direction for a distance of two hundred and fifteen (215) feet. Four (4) hour parking. (5/5/94) (7/14/11)

Federal Street – Parking Meters Zones Established - northerly side, from the intersection of Washington Street, proceeding to two hundred seventeen (217) feet east of North Street. Four (4) hour parking. (7/20/87)

And inserting the following:

Federal Street – Zones Established – Northerly side, beginning at the intersection of Washington Street and proceeding in a westerly direction to a point two hundred and sixty-three (263) feet east of the intersection with North Street. Four (4) hour parking.

Federal Street – Zones Established – Southerly side, beginning at a point forty (40) feet west of the intersection with Washington Street and proceeding in a westerly direction for a distance of one hundred and fifty (150) feet. Four (4) hour parking.

**Section 4.** Section 74 of Article V-A be amended by repealing the following:

Federal Street – General Prohibition Towing Zones - northerly side, from the intersection of Federal and Washington Streets and proceeding eighty nine (89) feet in a westerly direction except marked emergency vehicles, Monday through Friday. (12/1/88)

Federal Street – General Prohibition Towing Zones - in an easterly direction, two hundred and seventeen (217) feet from North Street. (2/2/78 DPW 5-1375)

Federal Street – General Prohibition Towing Zones - in front of #56, as marked by signs for a distance of one hundred (100) feet, Marked Police Vehicle Parking only, Tow Zone, Monday to Friday, 7:00 AM to 5:00 PM. (1/26/12)

And inserting the following:

Federal Street – General Prohibition Towing Zones – Southerly side, beginning at the intersection of Federal and Washington Streets and proceeding in a westerly direction for a distance of forty (40) feet.

Federal Street - General Prohibition Towing Zones – Northerly side, beginning at a point two hundred and thirty (230) feet east of North Street and proceeding in a westerly direction for a distance of one hundred and seventy-five (175) feet. Marked Police Vehicle Parking Only, Tow Zone, Monday to Friday, 7:00 A.M. to 5:00 P.M.

**Section 5.** Section 75 of Article V-A be amended by repealing the following:

Federal Street – Parking Prohibitions Towing Zone (Resident Sticker) - ZONE C-COLOR GREEN-southerly side, beginning one hundred and fifty (150) feet from the intersection of Washington Street and Federal Street in a westerly direction for a distance of one hundred and fifty-five (155) feet. "Resident Parking Only 5:00 P.M. to 9:00 A.M. (5/5/94)

Federal Street – Parking Prohibitions Towing Zone (Resident Sticker) - ZONE C-COLOR GREEN-southerly side, beginning three hundred and five (305) feet from the intersection of Washington Street and Federal Street, in a Westerly direction to the intersection of North Street, Resident Sticker Parking Only, Tow Zone. ( 6/14/18 )

And inserting the following:

Federal Street – Parking Prohibitions Towing Zone (Resident Sticker) - Zone C – Color Green – Southerly side, beginning at a point two hundred and twenty-five (225) feet west of the intersection of Washington and Federal Streets, in a westerly direction to the intersection of North Street and Federal Street, Resident Sticker Parking Only, Tow Zone.

**Section 6.** This ordinance shall take effect as provided by City Charter.

## Ilene Simons

---

**From:** David Kucharsky  
**Sent:** Wednesday, March 15, 2023 10:30 AM  
**To:** Ilene Simons  
**Cc:** Maureen Fisher; Chris Sicuranza; Caroline Watson-Felt; David M. Tucker; Christina Hodge; Brendan Linard  
**Subject:** Federal Street Ordinance Amendments  
**Attachments:** Proposed Ordinance Changes - Federal Between North and Washington.docx; Notice to Council - T&P Commission Action re Federal Wash-North.docx; Proposed Ordinance Changes - Federal Street.docx

Ilene,

Attached are ordinance amendments for the following sections of Federal Street:

- Federal Street Washington to North – In addition to cleaning up older ordinances that are no longer applicable, the amendments seek to convert four metered spaces, which provide overnight resident parking, to full time resident permit parking. These recommendations were presented to the Traffic and Parking Commission last March and were approved unanimously. Summary of the meeting is attached as well as a link to the meeting minutes is provided below.
- Federal Street North to Boston – Additional cleanup of past ordinances as well as extending resident permit parking from 82 Federal to North St. This amendment was discussed with the Ward Councilor and Lt. Tucker to account for the conversion of offices to residences along this stretch of Federal and allow some residents on North St to purchase permits .

[https://www.salemma.gov/sites/g/files/vyhlf7986/f/minutes/meeting\\_minutes\\_march\\_23\\_2022\\_final.pdf](https://www.salemma.gov/sites/g/files/vyhlf7986/f/minutes/meeting_minutes_march_23_2022_final.pdf)

David Kucharsky  
Director of Traffic & Parking  
98 Washington Street, 2<sup>nd</sup> Floor  
Salem, MA 01970  
978-619-5697





**City of Salem, Massachusetts**  
**Traffic and Parking Commission**  
 98 Washington Street, 2<sup>nd</sup> Floor  
 Salem, MA 01970  
[www.salem.com](http://www.salem.com)

Robert McCarthy, Acting Mayor

David Kucharsky, Traffic and Parking Director

## Notice to the City Council of Traffic and Parking Commission Action

At a meeting of the Salem Traffic and Parking Commission held on March 23, 2022 and attended by:

- Tanya Shallop, Chair
- Eric Papetti, Vice Chair
- Jaime Garmendia
- Jeff Swartz
- Lt. David Tucker

The Commission took the following action:

- Advisory Recommendation
- Ordinance Change Recommendation
  - Handicap Parking
  - Resident Parking
  - Other Change

**Background and notes:** Early in 2022, City staff reviewed the parking conditions on Federal Street between Washington Street and North Street. City staff worked with a consultant to develop a striping plan with the goal of clarifying parking for metered spaces, resident parking and uses associated with adjacent court houses. As part of this effort, staff introduced several recommended ordinance changes to go along with the proposed striping layout. These changes were brought before the Traffic and Parking Commission at the March 23, 2022 meeting. At this meeting, the commissioners reviewed the proposed changes, which adds two additional parking spaces overall and converts some spaces that are currently residential at certain times and metered at other times to be full-time residential spaces. The Commission has recommended the changes be adopted by Council.

**Motion and Vote:** *On a motion duly made by Commissioner Swartz and seconded by Commissioner Tucker, the Traffic and Parking Commission voted to recommend the proposed changes to the traffic ordinance for Federal Street between Washington Street and North Street as proposed by City staff. **The vote is five (5) in favor, and none (0) opposed, the motion passes.***

Vote:

The motion was made by Commissioner Swartz and seconded by Commissioner Tucker.

In Favor:

- Tanya Stepasiuk, Chair
- Eric Papetti, Vice Chair
- Jaime Garmendia
- Jeff Swartz
- Lt. David Tucker

Opposed:

- Tanya Stepasiuk, Chair
- Eric Papetti, Vice Chair
- Jaime Garmendia
- Jeff Swartz
- Lt. David Tucker

Abstained:

- Tanya Stepasiuk, Chair
- Eric Papetti, Vice Chair
- Jaime Garmendia
- Jeff Swartz
- Lt. David Tucker



City of Salem, Massachusetts  
Office of the City Council  
City Hall



**REQUEST FOR TRAFFIC ORDINANCE RECOMMENDATION**

MEMO TO: Lt. David Tucker Police Traffic Division  
FROM: Councilor Watson-Felt DATE: March 20, 2023

In accordance with the Council Rule 32A, I hereby request your recommendation for the following Traffic Ordinance:

NAME OF STREET Federal Street

TYPE OF STREET CHANGE Handicapped Zones

DESCRIPTION OF AREA WHERE CHANGE IS REQUESTED In front of 56 Federal Street.

COUNCILLOR'S COMMENTS/EXPLANATION There has been an HP sign in front of 56 Federal Street for some time; this ordinance will make it official. The space is necessary to serve the court complex.

**POLICE TRAFFIC DIVISION RECOMMENDATION**

The Police Traffic Division hereby submits the following recommendation for the above request:

APPROVAL

DENIAL

TRIAL PERIOD

CHAPTER: 42 SECTION: 50A TITLE: Handicapped Zones

DESCRIPTION: Federal Street – Handicapped Zones – Northerly side, beginning at a point two hundred and thirty (230) feet east of North Street and running in an easterly direction for twenty (20) feet.

COMMENTS (IF ANY): \_\_\_\_\_

Lt. David Tucker  
POLICE TRAFFIC DIVISION

**RETURN THIS FORM TO THE CITY CLERK'S OFFICE**

City of Salem Clerk's Office, 93 Washington St, Salem Massachusetts 01970

(978) 745-9595 ext 41202 www.salem.com



**City of Salem, Massachusetts**  
 Office of the City Council  
 City Hall



**REQUEST FOR TRAFFIC ORDINANCE RECOMMENDATION**

MEMO TO: Lt. David Tucker Police Traffic Division  
 FROM: Councilor Watson-Felt DATE: March 20, 2023

In accordance with the Council Rule 32A, I hereby request your recommendation for the following Traffic Ordinance:

NAME OF STREET Federal Street  
 TYPE OF STREET CHANGE Parking Prohibited on Certain Streets  
 DESCRIPTION OF AREA WHERE CHANGE IS REQUESTED Federal Street near the intersection with North Street.  
 COUNCILLOR'S COMMENTS/EXPLANATION Federal Street narrows significantly as it approaches North Street, and parking is heavily used in this area. When cars park too close to North Street, traffic has a very difficult time passing.

**POLICE TRAFFIC DIVISION RECOMMENDATION**

The Police Traffic Division hereby submits the following recommendation for the above request:

APPROVAL  
 DENIAL  
 TRIAL PERIOD

CHAPTER: 42 SECTION: 51 TITLE: Parking Prohibited on Certain Streets  
 DESCRIPTION: Federal Street – Northerly side, beginning at a point fifty-five (55) feet east of North Street and running in a westerly direction to the intersection with North Street, "No Parking Here to Corner"  
 COMMENTS (IF ANY): \_\_\_\_\_

\_\_\_\_\_  
**POLICE TRAFFIC DIVISION**

**RETURN THIS FORM TO THE CITY CLERK'S OFFICE**



City of Salem, Massachusetts  
Office of the City Council  
City Hall



**REQUEST FOR TRAFFIC ORDINANCE RECOMMENDATION**

MEMO TO: Lt. David Tucker Police Traffic Division  
FROM: Councilor Watson-Felt DATE: March 20, 2023

In accordance with the Council Rule 32A, I hereby request your recommendation for the following Traffic Ordinance:

NAME OF STREET Federal Street

TYPE OF STREET CHANGE Zones Established

DESCRIPTION OF AREA WHERE CHANGE IS REQUESTED Federal Street, between Washington Street and North Street.

COUNCILLOR'S COMMENTS/EXPLANATION Repeal of older four hour parking zone language on the South side of Federal Street near Washington Street.

**POLICE TRAFFIC DIVISION RECOMMENDATION**

The Police Traffic Division hereby submits the following recommendation for the above request:

XX APPROVAL

       DENIAL

       TRIAL PERIOD

CHAPTER: 42 SECTION: 56 TITLE: Zones Established

DESCRIPTION: Repeal: Federal Street – southerly side, beginning one hundred and fifty (150) feet from the intersection of Washington Street and Federal Street in a westerly direction for a distance of two hundred and fifteen (215) feet. Four (4) hour parking. (5/5/94) (7/14/11)

COMMENTS (IF ANY):       

Lt. David Tucker

**POLICE TRAFFIC DIVISION**

**RETURN THIS FORM TO THE CITY CLERK'S OFFICE**

City of Salem Clerk's Office, 93 Washington St, Salem, Massachusetts 01970

(978) 745-9595 ext 41202 www.salem.com



City of Salem, Massachusetts  
Office of the City Council  
City Hall



**REQUEST FOR TRAFFIC ORDINANCE RECOMMENDATION**

MEMO TO: Lt. David Tucker Police Traffic Division  
FROM: Councilor Watson-Felt DATE: March 20, 2023

In accordance with the Council Rule 32A, I hereby request your recommendation for the following Traffic Ordinance:

NAME OF STREET Federal Street

TYPE OF STREET CHANGE Parking Meters Zones Established

DESCRIPTION OF AREA WHERE CHANGE IS REQUESTED Federal Street, between Washington Street and North Street.

COUNCILLOR'S COMMENTS/EXPLANATION Repeal of older meter parking zone language on the North side of Federal Street near Washington Street.

**POLICE TRAFFIC DIVISION RECOMMENDATION**

The Police Traffic Division hereby submits the following recommendation for the above request:

XX APPROVAL

         DENIAL

         TRIAL PERIOD

CHAPTER: 42 SECTION: 56 TITLE: Parking Meters Zones Established

DESCRIPTION: Repeal: Federal Street – Parking Meters Zones Established - northerly side, from the intersection of Washington Street, proceeding to two hundred seventeen (217) feet east of North Street.

Four (4) hour parking. (7/20/87)

COMMENTS (IF ANY):         

*Lt. David Tucker*

**POLICE TRAFFIC DIVISION**

**RETURN THIS FORM TO THE CITY CLERK'S OFFICE**

*City of Salem Clerk's Office, 93 Washington St, Salem Massachusetts 01970*

*(978) 745-9595 ext 41202 www.salem.com*







**City of Salem, Massachusetts**  
Office of the City Council  
City Hall



**REQUEST FOR TRAFFIC ORDINANCE RECOMMENDATION**

MEMO TO: Lt. David Tucker Police Traffic Division  
FROM: Councilor Watson-Felt DATE: March 20, 2023

In accordance with the Council Rule 32A, I hereby request your recommendation for the following Traffic Ordinance:

NAME OF STREET Federal Street

TYPE OF STREET CHANGE General Prohibition Towing Zones

DESCRIPTION OF AREA WHERE CHANGE IS REQUESTED Federal Street, between Washington Street and North Street.

COUNCILLOR'S COMMENTS/EXPLANATION Repeal of older no parking zone on Federal Street that has been superseded.

**POLICE TRAFFIC DIVISION RECOMMENDATION**

The Police Traffic Division hereby submits the following recommendation for the above request:

XX APPROVAL  
       DENIAL  
       TRIAL PERIOD

CHAPTER: 42 SECTION: 74 TITLE: General Prohibition Towing Zones

DESCRIPTION: Repeal: Federal Street – General Prohibition Towing Zones - northerly side, from the intersection of Federal and Washington Streets and proceeding eighty nine (89) feet in a westerly direction except marked emergency vehicles, Monday through Friday. (12/1/88)

COMMENTS (IF ANY): \_\_\_\_\_

\_\_\_\_\_

**POLICE TRAFFIC DIVISION**

**RETURN THIS FORM TO THE CITY CLERK'S OFFICE**

*City of Salem Clerk's Office, 93 Washington St. Salem Massachusetts 01970*

*(978) 745-9595 ext 41202 www.salem.com*



# City of Salem

*In the year Two Thousand and Twenty-Three*

## **An Ordinance Relative to Traffic**

*Be it ordained by the City Council of the City of Salem, as follows:*

**Section 1.** Section 50A of Article V be amended by inserting the following:

Federal Street – Handicapped Parking Zones – Northerly side, beginning at a point two hundred and thirty (230) feet east of North Street and running in an easterly direction for twenty (20) feet.

**Section 2.** Section 51 of Article V be amended by inserting the following:

Federal Street – Parking Prohibited on Certain Streets – Northerly side, beginning at a point fifty-five (55) feet east of North Street and running in a westerly direction to the intersection with North Street, “No Parking Here to Corner”

**Section 3.** Section 56 of Article V be amended by repealing the following:

Federal Street – Zones Established - southerly side, beginning one hundred and fifty (150) feet from the intersection of Washington Street and Federal Street in a westerly direction for a distance of two hundred and fifteen (215) feet. Four (4) hour parking. (5/5/94) (7/14/11)

Federal Street – Parking Meters Zones Established - northerly side, from the intersection of Washington Street, proceeding to two hundred seventeen (217) feet east of North Street. Four (4) hour parking. (7/20/87)

And inserting the following:

Federal Street – Zones Established – Northerly side, beginning at the intersection of Washington Street and proceeding in a westerly direction to a point two hundred and sixty-three (263) feet east of the intersection with North Street. Four (4) hour parking.

Federal Street – Zones Established – Southerly side, beginning at a point forty (40) feet west of the intersection with Washington Street and proceeding in a westerly direction for a distance of one hundred and fifty (150) feet. Four (4) hour parking.

**Section 4.** Section 74 of Article V-A be amended by repealing the following:

Federal Street – General Prohibition Towing Zones - northerly side, from the intersection of Federal and Washington Streets and proceeding eighty nine (89) feet in a westerly direction except marked emergency vehicles, Monday through Friday. (12/1/88)





City of Salem, Massachusetts  
Office of the City Council  
City Hall



**REQUEST FOR TRAFFIC ORDINANCE RECOMMENDATION**

MEMO TO: Lt. David Tucker Police Traffic Division  
FROM: Councilor Watson-Felt DATE: March 20, 2023

In accordance with the Council Rule 32A, I hereby request your recommendation for the following Traffic Ordinance:

NAME OF STREET Federal Street

TYPE OF STREET CHANGE General Prohibition Towing Zones

DESCRIPTION OF AREA WHERE CHANGE IS REQUESTED Federal Street, between Washington Street and North Street.

COUNCILLOR'S COMMENTS/EXPLANATION Repeal of older no parking zone on Federal Street that will be rewritten.

**POLICE TRAFFIC DIVISION RECOMMENDATION**

The Police Traffic Division hereby submits the following recommendation for the above request:

XX APPROVAL  
         DENIAL  
         TRIAL PERIOD

CHAPTER: 42 SECTION: 74 TITLE: General Prohibition Towing Zones

DESCRIPTION: Repeal: Federal Street – General Prohibition Towing Zones - in front of #56, as marked by signs for a distance of one hundred (100) feet, Marked Police Vehicle Parking only, Tow Zone, Monday to Friday, 7:00 AM to 5:00 PM. (1/26/12)

COMMENTS (IF ANY):         

Lt. David Tucker

**POLICE TRAFFIC DIVISION**

**RETURN THIS FORM TO THE CITY CLERK'S OFFICE**

*City of Salem Clerk's Office, 93 Washington St, Salem Massachusetts 01970*

*(978) 745-9595 ext 41202 www.salem.com*



**City of Salem, Massachusetts**  
Office of the City Council  
City Hall



**REQUEST FOR TRAFFIC ORDINANCE RECOMMENDATION**

MEMO TO: Lt. David Tucker Police Traffic Division  
FROM: Councilor Watson-Felt DATE: March 20, 2023

In accordance with the Council Rule 32A, I hereby request your recommendation for the following Traffic Ordinance:

**NAME OF STREET** Federal Street

**TYPE OF STREET CHANGE** General Prohibition Towing Zones

**DESCRIPTION OF AREA WHERE CHANGE IS REQUESTED** Federal Street, between Washington Street and North Street.

**COUNCILLOR'S COMMENTS/EXPLANATION** Rewrite of a no parking zone on Federal Street. No parking in the specified area, due to the narrow road width.

**POLICE TRAFFIC DIVISION RECOMMENDATION**

The Police Traffic Division hereby submits the following recommendation for the above request:

XX APPROVAL  
       DENIAL  
       TRIAL PERIOD

CHAPTER: 42 SECTION: 74 TITLE: General Prohibition Towing Zones

DESCRIPTION: Federal Street – General Prohibition Towing Zones - Southerly side, beginning at the intersection of Federal and Washington Streets and proceeding in a westerly direction for a distance of forty (40) feet.

COMMENTS (IF ANY): \_\_\_\_\_

\_\_\_\_\_

**POLICE TRAFFIC DIVISION**

**RETURN THIS FORM TO THE CITY CLERK'S OFFICE**

*City of Salem Clerk's Office, 93 Washington St, Salem, Massachusetts 01970*

*(978) 45-9595 ext 41202 www.salem.com*





**City of Salem, Massachusetts**  
Office of the City Council  
City Hall



**REQUEST FOR TRAFFIC ORDINANCE RECOMMENDATION**

MEMO TO: Lt. David Tucker Police Traffic Division  
FROM: Councilor Watson-Felt DATE: March 20, 2023

In accordance with the Council Rule 32A, I hereby request your recommendation for the following Traffic Ordinance:

NAME OF STREET Federal Street

TYPE OF STREET CHANGE Parking Prohibitions Towing Zones (Resident Sticker)

DESCRIPTION OF AREA WHERE CHANGE IS REQUESTED Federal Street, between Washington Street and North Street.

COUNCILLOR'S COMMENTS/EXPLANATION Repeal of a resident sticker zone on Federal Street. Part of a clean-up the ordinance language in this area.

**POLICE TRAFFIC DIVISION RECOMMENDATION**

The Police Traffic Division hereby submits the following recommendation for the above request:

XX APPROVAL

\_\_\_\_\_ DENIAL

\_\_\_\_\_ TRIAL PERIOD

CHAPTER: 42 SECTION: 75 TITLE: Parking Prohibitions Towing Zones (Resident Sticker)

DESCRIPTION: Repeal: Federal Street – Parking Prohibitions Towing Zones (Resident Sticker) – ZONE C-COLOR GREEN-southerly side, beginning one hundred and fifty (150) feet from the intersection of Washington Street and Federal Street in a westerly direction for a distance of one hundred and fifty-five (155) feet. "Resident Parking Only 5:00 P.M. to 9:00 A.M. (5/5/94)

COMMENTS (IF ANY): \_\_\_\_\_

**POLICE TRAFFIC DIVISION**

**RETURN THIS FORM TO THE CITY CLERK'S OFFICE**

*City of Salem Clerk's Office, 93 Washington St, Salem Massachusetts 01970*

*(978) 745-9595 ext 41202 www.salem.com*



**City of Salem, Massachusetts**  
Office of the City Council  
City Hall



**REQUEST FOR TRAFFIC ORDINANCE RECOMMENDATION**

MEMO TO: Lt. David Tucker Police Traffic Division  
FROM: Councilor Watson-Felt DATE: March 20, 2023

In accordance with the Council Rule 32A, I hereby request your recommendation for the following Traffic Ordinance:

NAME OF STREET Federal Street  
TYPE OF STREET CHANGE Parking Prohibitions Towing Zones (Resident Sticker)  
DESCRIPTION OF AREA WHERE CHANGE IS REQUESTED Federal Street, between Washington Street and North Street.  
COUNCILLOR'S COMMENTS/EXPLANATION Repeal of a resident sticker zone on Federal Street. Part of a clean-up the ordinance language in this area.

**POLICE TRAFFIC DIVISION RECOMMENDATION**

The Police Traffic Division hereby submits the following recommendation for the above request:

XX APPROVAL  
           DENIAL  
           TRIAL PERIOD

CHAPTER: 42 SECTION: 75 TITLE: Parking Prohibitions Towing Zones (Resident Sticker)  
DESCRIPTION: Repeal: Federal Street – Parking Prohibitions Towing Zones (Resident Sticker) – ZONE C-COLOR GREEN - southerly side, beginning three hundred and five (305) feet from the intersection of Washington Street and Federal Street, in a Westerly direction to the intersection of North Street, Resident Sticker Parking Only, Tow Zone. ( 6/14/18 )  
COMMENTS (IF ANY): \_\_\_\_\_

POLICE TRAFFIC DIVISION

**RETURN THIS FORM TO THE CITY CLERK'S OFFICE**

*City of Salem Clerk's Office, 93 Washington St, Salem Massachusetts 01970*

*(978) 745-9595 ext 41202 www.salem.com*



**City of Salem, Massachusetts**  
**Office of the City Council**  
**City Hall**



**REQUEST FOR TRAFFIC ORDINANCE RECOMMENDATION**

MEMO TO: Lt. David Tucker Police Traffic Division  
 FROM: Councilor Watson-Felt DATE: March 20, 2023

In accordance with the Council Rule 32A, I hereby request your recommendation for the following Traffic Ordinance:

NAME OF STREET Federal Street  
 TYPE OF STREET CHANGE Parking Prohibitions Towing Zones (Resident Sticker)  
 DESCRIPTION OF AREA WHERE CHANGE IS REQUESTED Federal Street, between Washington Street and North Street.  
 COUNCILLOR'S COMMENTS/EXPLANATION Re-establish a resident sticker zone on Federal Street. Part of a clean-up the ordinance language in this area.

**POLICE TRAFFIC DIVISION RECOMMENDATION**

The Police Traffic Division hereby submits the following recommendation for the above request:

XX APPROVAL  
 \_\_\_\_\_ DENIAL  
 \_\_\_\_\_ TRIAL PERIOD

CHAPTER: 42 SECTION: 75 TITLE: Parking Prohibitions Towing Zones (Resident Sticker)  
 DESCRIPTION: Federal Street – Parking Prohibitions Towing Zones (Resident Sticker) – Zone C – Color Green – Southerly side, beginning at a point two hundred and twenty-five (225) feet west of the intersection of Washington and Federal Streets, in a westerly direction to the intersection of North Street and Federal Street, Resident Sticker Parking Only, Tow Zone.  
 COMMENTS (IF ANY): \_\_\_\_\_

\_\_\_\_\_  
**POLICE TRAFFIC DIVISION**

**RETURN THIS FORM TO THE CITY CLERK'S OFFICE**



# City of Salem

*In the year Two Thousand and Twenty-Three*

## **An Ordinance Relative to Traffic**

*Be it ordained by the City Council of the City of Salem, as follows:*

**Section 1.** Section 51B of Article V be amended by repealing the following:

Lafayette Street – Parking Prohibited at Certain Times on Certain Streets - easterly side, beginning at the intersection of Ocean Avenue and running in a southerly direction for a distance of one hundred (100) feet. Two (2) hour parking. (11/18/76 DPW 5-1236)

Lafayette Street – Parking Prohibited at Certain Times on Certain Streets - easterly side, extending one hundred (100) feet from Ocean Avenue. Two (2) hour parking. (10/5/76 DPW 5-1210)

Ocean Avenue - Parking Prohibited at Certain Times on Certain Streets - southerly side, beginning at Lafayette Street and running in an easterly direction for one hundred fifty-eight (158) feet, two (2) hour parking. (11/12/15)

Ocean Avenue - Parking Prohibited at Certain Times on Certain Streets - from Lafayette Street to the westerly property line of #39 Ocean Avenue, total distance one hundred and fifty-eight (158) feet. (11/12/15)

**Section 2.** Section 57A of Article V be amended by repealing the following:

Ocean Avenue – Parking Time Limited: Unmetered Zones - northerly side, starting at Lafayette Street and running to the rear property line of 284 Lafayette Street. Two (2) hour parking, Monday through Friday 9:00 A.M. to 6:00 P.M. Resident parking also authorized. (10/13/16 )

And inserting the following:

Lafayette Street – Parking Time Limited: Unmetered Zones – easterly side, beginning at Ocean Avenue and running in a southerly direction for seventy-eight (78) feet, Two (2) hour parking, Monday through Friday, 8:00 A.M. to 6:00 P.M.

Ocean Avenue – Parking Time Limited: Unmetered Zones – northerly side, beginning at Lafayette Street and running in a westerly direction, ninety-two (92) feet, one (1) hour nonresident parking allowed, Monday through Friday, 9:00 A.M. to 6:00 P.M.

Ocean Avenue – Parking Time Limited: Unmetered Zones – southerly side, beginning at a point one hundred and three (103) feet west of Lafayette Street and running in an easterly direction to Lafayette Street, one (1) hour nonresident parking allowed, Monday through Friday, 9:00 A.M. to 6:00 P.M.

Ocean Avenue – Parking Time Limited: Unmetered Zones – southerly side, beginning at Lafayette Street and running in an easterly direction for one hundred fifty-five (155) feet, two (2) hour nonresident parking allowed, Monday through Friday, 8:00 A.M. to 6:00 P.M.

**Section 3.** Section 75 of Article V-A be amended by repealing the following:

Ocean Avenue – Parking Prohibitions Towing Zone (Resident Sticker) - Zone E Color Orange - starting from No. 50, both sides, running in a westerly direction to Canal Street.  
(10/2/90)

**Section 4.** This ordinance shall take effect as provided by City Charter.

Ocean at Lafayette Ordinance Changes – Proposed Condition

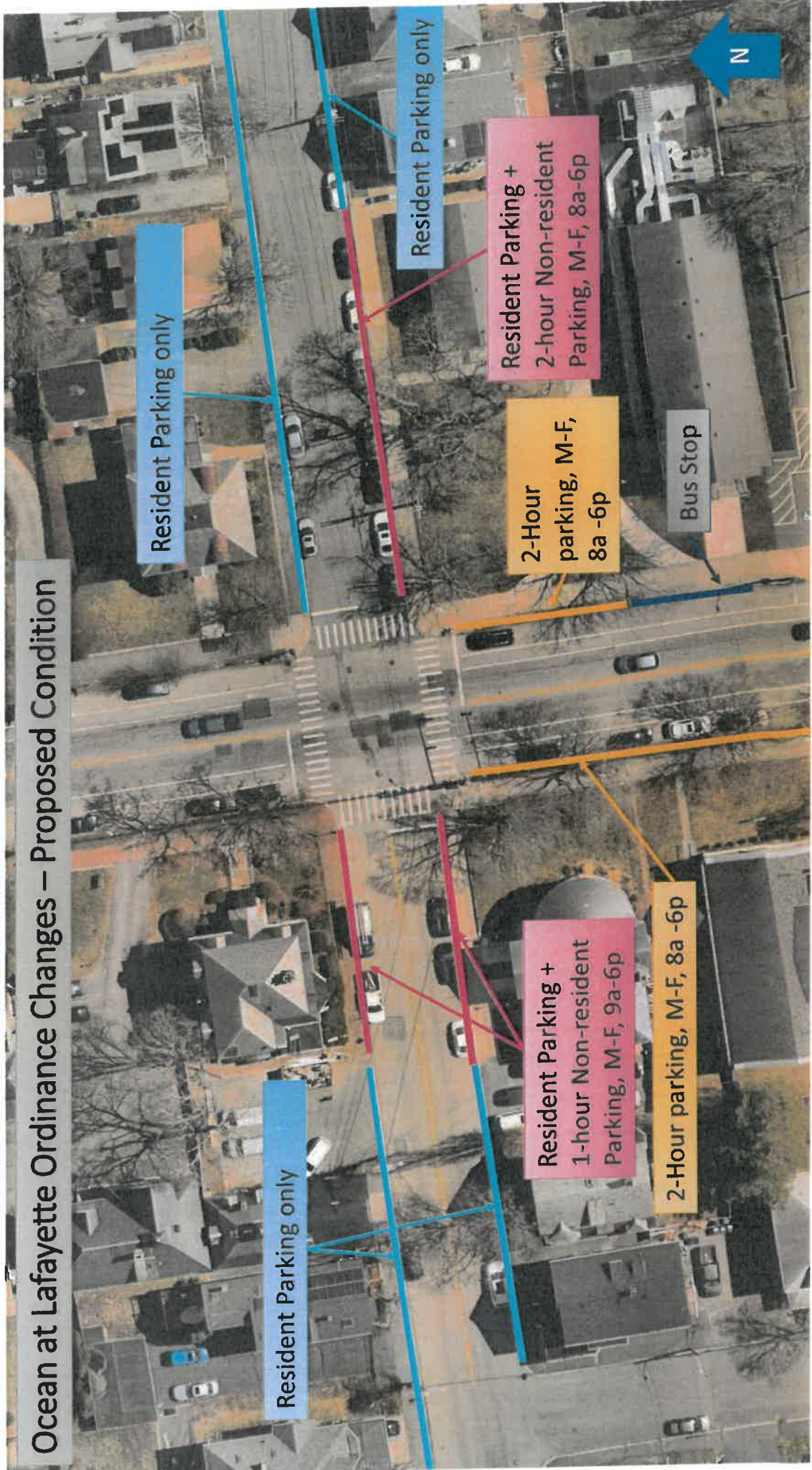

Resident Parking only

Resident Parking only

Resident Parking +  
2-hour Non-resident  
Parking, M-F, 8a-6p

2-Hour  
parking, M-F,  
8a -6p

Bus Stop

Resident Parking only

Resident Parking +  
1-hour Non-resident  
Parking, M-F, 9a-6p

2-Hour parking, M-F, 8a -6p

N



**City of Salem, Massachusetts**  
Office of the City Council  
City Hall



**REQUEST FOR TRAFFIC ORDINANCE RECOMMENDATION**

MEMO TO: Lt. David Tucker Police Traffic Division  
FROM: Councilor Cohen DATE: March 20, 2023

In accordance with the Council Rule 32A, I hereby request your recommendation for the following Traffic Ordinance:

NAME OF STREET Lafayette Street, Ocean Avenue

TYPE OF STREET CHANGE Parking Prohibited at Certain Times on Certain Streets

DESCRIPTION OF AREA WHERE CHANGE IS REQUESTED Lafayette Street and Ocean Avenue

COUNCILLOR'S COMMENTS/EXPLANATION Repeal of older time limited parking zone language on Lafayette Street and Ocean Avenue.

**POLICE TRAFFIC DIVISION RECOMMENDATION**

The Police Traffic Division hereby submits the following recommendation for the above request:

- APPROVAL
- DENIAL
- TRIAL PERIOD

CHAPTER: 42 SECTION: 51B TITLE: Parking Prohibited at Certain Times on Certain Streets

DESCRIPTION: **Repeal:** Lafayette Street – Parking Prohibited at Certain Times on Certain Streets – easterly side, beginning at the intersection of Ocean Avenue and running in a southerly direction for a distance of one hundred (100) feet. Two (2) hour parking. (11/18/76 DPW 5-1236)

**Repeal:** Lafayette Street – Parking Prohibited at Certain Times on Certain Streets - easterly side, extending one hundred (100) feet from Ocean Avenue. Two (2) hour parking. (10/5/76 DPW 5-1210)

**Repeal:** Ocean Avenue - Parking Prohibited at Certain Times on Certain Streets - southerly side, beginning at Lafayette Street and running in an easterly direction for one hundred fifty-eight (158) feet, two (2) hour parking. (11/12/15)

**Repeal:** Ocean Avenue - Parking Prohibited at Certain Times on Certain Streets - from Lafayette Street to the westerly property line of #39 Ocean Avenue, total distance one hundred and fifty-eight (158) feet.



(11/12/15)

COMMENTS (IF ANY):



**POLICE TRAFFIC DIVISION**

**RETURN THIS FORM TO THE CITY CLERK'S OFFICE**

*City of Salem Clerk's Office, 93 Washington St, Salem Massachusetts 01970*

*(978) 745-9595 ext 41202 [www.salem.com](http://www.salem.com)*



**City of Salem, Massachusetts**  
Office of the City Council  
City Hall



**REQUEST FOR TRAFFIC ORDINANCE RECOMMENDATION**

MEMO TO: Lt. David Tucker Police Traffic Division  
FROM: Councilor Cohen DATE: March 20, 2023

In accordance with the Council Rule 32A, I hereby request your recommendation for the following Traffic Ordinance:

NAME OF STREET Lafayette Street, Ocean Avenue

TYPE OF STREET CHANGE Parking Time Limited: Unmetered Zones

DESCRIPTION OF AREA WHERE CHANGE IS REQUESTED Lafayette Street and Ocean Avenue

COUNCILLOR'S COMMENTS/EXPLANATION Repeal and rewrite of time limited parking zone language on Lafayette Street and Ocean Avenue.

**POLICE TRAFFIC DIVISION RECOMMENDATION**

The Police Traffic Division hereby submits the following recommendation for the above request:

- XX APPROVAL
- \_\_\_\_\_ DENIAL
- \_\_\_\_\_ TRIAL PERIOD

CHAPTER: 42 SECTION: 57A TITLE: Parking Time Limited: Unmetered Zones

DESCRIPTION: **Repeal:** Ocean Avenue – Parking Time Limited: Unmetered Zones - northerly side, starting at Lafayette Street and running to the rear property line of 284 Lafayette Street. Two (2) hour parking, Monday through Friday 9:00 A.M. to 6:00 P.M. Resident parking also authorized. (10/13/16)

**Insert:** Lafayette Street – Parking Time Limited: Unmetered Zones – easterly side, beginning at Ocean Avenue and running in a southerly direction for seventy-eight (78) feet. Two (2) hour parking, Monday through Friday, 8:00 A.M. to 6:00 P.M.

**Insert:** Ocean Avenue – Parking Time Limited: Unmetered Zones – northerly side, beginning at Lafayette Street and running in a westerly direction, ninety-two (92) feet, one (1) hour nonresident parking allowed, Monday through Friday, 9:00 A.M. to 6:00 P.M.

**Insert:** Ocean Avenue – Parking Time Limited: Unmetered Zones – southerly side, beginning at a point

one hundred and three (103) feet west of Lafayette Street and running in an easterly direction to Lafayette Street, one (1) hour nonresident parking allowed, Monday through Friday, 9:00 A.M. to 6:00 P.M.

**Insert: Ocean Avenue – Parking Time Limited: Unmetered Zones – southerly side, beginning at Lafayette Street and running in an easterly direction for one hundred fifty-five (155) feet, two (2) hour nonresident parking allowed, Monday through Friday, 8:00 A.M. to 6:00 P.M.**

COMMENTS (IF ANY): \_\_\_\_\_

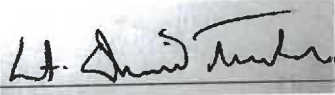
  
\_\_\_\_\_

**POLICE TRAFFIC DIVISION**

**RETURN THIS FORM TO THE CITY CLERK'S OFFICE**

*City of Salem Clerk's Office, 93 Washington St, Salem Massachusetts 01970*

*(978) 745-9595 ext 41202 www.salem.com*



**City of Salem, Massachusetts**  
Office of the City Council  
City Hall



**REQUEST FOR TRAFFIC ORDINANCE RECOMMENDATION**

MEMO TO: Lt. David Tucker Police Traffic Division  
FROM: Councilor Cohen DATE: March 20, 2023

In accordance with the Council Rule 32A, I hereby request your recommendation for the following Traffic Ordinance:

NAME OF STREET Ocean Avenue

TYPE OF STREET CHANGE Parking Prohibitions Towing Zone (Resident Sticker)

DESCRIPTION OF AREA WHERE CHANGE IS REQUESTED Ocean Avenue

COUNCILLOR'S COMMENTS/EXPLANATION Repeal resident sticker parking zone, part of a clean up of parking restriction language on Ocean Avenue.

**POLICE TRAFFIC DIVISION RECOMMENDATION**

The Police Traffic Division hereby submits the following recommendation for the above request:

XX APPROVAL  
       DENIAL  
       TRIAL PERIOD

CHAPTER: 42 SECTION: 75 TITLE: Parking Prohibitions Towing Zone (Resident Sticker)

DESCRIPTION: Repeal: Ocean Avenue - Parking Prohibitions Towing Zone (Resident Sticker) - Zone E Color Orange - starting from No. 50, both sides, running in a westerly direction to Canal Street. (10/2/90)

COMMENTS (IF ANY): \_\_\_\_\_

\_\_\_\_\_

**POLICE TRAFFIC DIVISION**

**RETURN THIS FORM TO THE CITY CLERK'S OFFICE**

*City of Salem Clerk's Office, 93 Washington St, Salem Massachusetts 01970*

*(978) 745-9595 ext 41202 www.salem.com*



## **Ilene Simons**

---

**From:** David Kucharsky  
**Sent:** Tuesday, March 14, 2023 12:16 PM  
**To:** Ilene Simons  
**Cc:** David M. Tucker; Maureen Fisher; Chris Sicuranza; Jeff Cohen  
**Subject:** Ocean Ave @ Lafayette St - Ordinance Amendments  
**Attachments:** Proposed Ordinance Changes - Ocean at Lafayette.docx; Ocean at Lafayette Proposed Changes.pdf

Ilene,

Attached please find an ordinance amendment which seeks to clarify resident parking and time limited parking at the intersection of Ocean and Lafayette. Also attached is a map which identifies what the regulations would be if City Council approves. If approved, we would work with DPS to have any signage updated in this area.

David Kucharsky  
Director of Traffic & Parking  
98 Washington Street, 2<sup>nd</sup> Floor  
Salem, MA 01970  
978-619-5697

City of Salem

**In the year two thousand and twenty-three**

**An Ordinance** to amend an Ordinance relative to Traffic

*Be it Ordained by the City Council of the City of Salem, as follows:*

**Section 1.** Chapter 42, Section 50B – “Handicap Zone Limited Time” is hereby amended by adding the following:

Albion Street - in Front of #33 for a distance of twenty (20) feet,  
“Handicap Parking, Limited Time, Tow Zone”

**Section 2.** This Ordinance shall take effect as provided by City Charter.



**City of Salem, Massachusetts**  
Office of the City Council  
City Hall



**REQUEST FOR TRAFFIC ORDINANCE RECOMMENDATION**

MEMO TO: Lt. David Tucker Police Traffic Division  
FROM: Councilor McClain DATE: March 20, 2023

In accordance with the Council Rule 32A, I hereby request your recommendation for the following Traffic Ordinance:

NAME OF STREET Albion Street

TYPE OF STREET CHANGE Handicapped Zones, Limited Time

DESCRIPTION OF AREA WHERE CHANGE IS REQUESTED In front of 33 Albion Street.

COUNCILLOR'S COMMENTS/EXPLANATION The resident of 33 Albion Street is disabled and uses an HP placard with their vehicle. Their off-street parking is difficult to use, and the on-street parking is heavily used. The resident has requested an HP space in front of their home to make access easier.

**POLICE TRAFFIC DIVISION RECOMMENDATION**

The Police Traffic Division hereby submits the following recommendation for the above request:

APPROVAL

DENIAL

TRIAL PERIOD

CHAPTER: 42 SECTION: 50B TITLE: Handicapped Zones, Limited Time

DESCRIPTION: Albion Street – Handicapped Zones; Limited Time – in front of #33, for a distance of twenty (20) feet.

COMMENTS (IF ANY): \_\_\_\_\_

**POLICE TRAFFIC DIVISION**

**RETURN THIS FORM TO THE CITY CLERK'S OFFICE**

*City of Salem Clerk's Office, 93 Washington St. Salem Massachusetts 01970*

*(978) 745-9595 ext 41202 www.salem.com*



David R. Flewelling  
Specialist 2 Construction  
Comcast Cable Communications  
9 Forbes Road, Suite 9B  
Woburn, MA 01801  
Cell – 617-279-7864  
[dave\\_flewelling@comcast.com](mailto:dave_flewelling@comcast.com)

March 14, 2023

Ms. Maureen Fisher  
Salem Assistant City Clerk  
City Hall  
93 Washington Street  
Salem, MA 01970

RE: Norman Street Salem  
Grant of Location-Petition

Dear Ms. Fisher:

Enclosed please find materials supporting Comcast request for a grant of location from the Salem City Council. The work associated with the attached petition is for the purpose of installing a new conduit to provide the Comcast Service to number 2 Margin Street. Please note that the work is located on Norman Street. For a more detailed description of the work please refer to the attached construction plans.

I look forward to the opportunity to address this matter in further detail at the next Salem City Council Meeting. Should you have any questions or concerns, please feel free to contact me at (617) 279-7864.

Sincerely,

A handwritten signature in black ink, appearing to read "David R. Flewelling", is written over the typed name and title.

David R. Flewelling  
Comcast  
Specialist 2, Construction

Enclosure (3)

PETITION OF COMCAST FOR LOCACTION FOR CONDUITS, MANHOLES AND  
POLES

To the City Council for the City of Salem, Massachusetts:

Respectfully represents Comcast Cable Communications Management LLC., a company incorporated for the distribution of broadband services, that it desires to construct a line for such broadband under the public way or ways hereinafter specified.

Norman Street: Locating the existing Comcast Conduit on Norman Street and placing a proposed 3'x3'manhole. Continuing from the newly placed manhole excavating in a southerly direction to place (1) 3" PVC Conduit 48'+/- to a proposed 17"x 30" vault located in the sidewalk to provide the Comcast Service to number 2 Margin Street.

Wherefore, your petition prays that, after due notice and hearing as provided by law, the City Council may by Order grant your petitioner permission to construct, and a location for, such a line of conduits, manholes and poles with the necessary wires and cables therein, said conduits manholes and poles to be located, substantially as shown on the plan made by Dewsnap Engineering Associates dated March 14,2023 and filed here with, under the following public way or ways of said City of Salem.

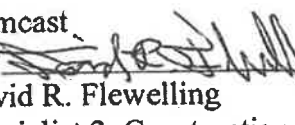
Comcast  
By:   
David R. Flewelling  
Specialist 2, Construction

Dated this March 14,2023

City of Salem, Massachusetts

Received and filed \_\_\_\_\_, 2023

\_\_\_\_\_

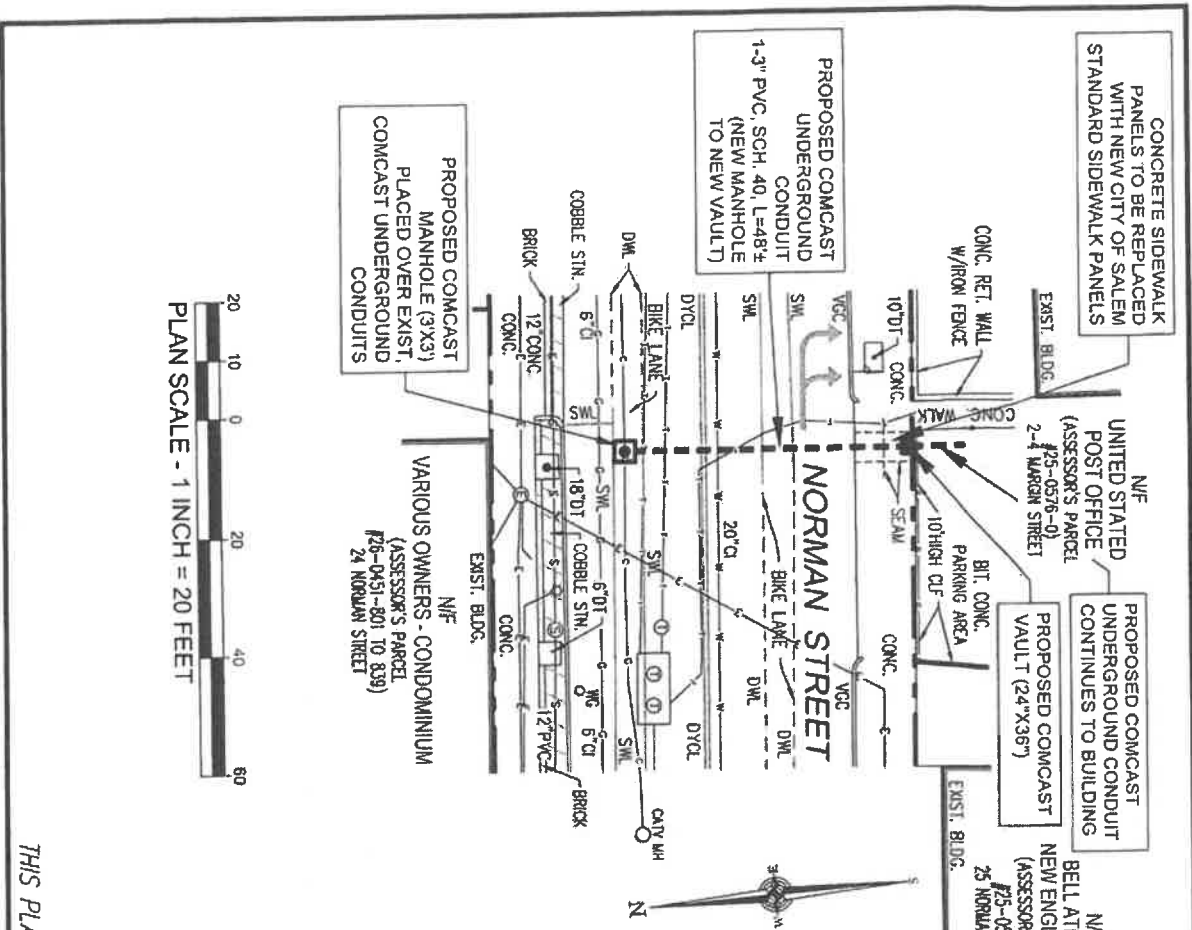

- NOTES:**
1. For notes see sheets 2 & 3.
  2. For construction details see sheets 2, 3 & 4.

THIS PLAN IS DRAWN ON 11" X 17" PAPER.



**LEGEND**

□ CB	CATCH BASIN	---	GAS LINE
⊗ LP	LIGHT POLE	---	WATER LINE
⊗ WC	WATER GATE	---	TELEPHONE LINE
△	FIRE HYDRANT	---	ELECTRIC CONDUIT
⊕	MANHOLE	---	SEWER LINE
⊖	TELEPHONE MANHOLE	---	DRAIN LINE
⊙	ELECTRIC MANHOLE	---	CATV LINE
□ EHH	ELECTRIC HAND HOLE	---	APPROX. P.L.
⊙	SEWER MANHOLE	---	PROPOSED COMCAST UNDERGROUND CONDUIT
⊖	DRAIN MANHOLE	---	DBL. YELLOW CENTER LINE
⊖	VERTICAL GRANITE CURB	---	SINGLE YELLOW EDGE LINE
SGC	SLOPED GRANITE CURB	---	SINGLE WHITE EDGE LINE
PCC	PRECAST CONCRETE CURB	---	SINGLE WHITE LANE LINE
⊖	UTILITY POLE	---	SINGLE WHITE LINE
⊖	SIGN	---	DASHED WHITE LINE
⊖	SIGN	---	STEEL POLLARD
⊖	DECIDUOUS TREE	---	EDGE OF PAVEMENT
		---	EOP
		---	GRS
		---	GALVANIZED RIGID STEEL

**WARD 2, PRECINCT 2**  
**PROPOSED COMCAST UNDERGROUND**  
**ESSEX COUNTY**  
**PLAN OF LAND**  
**IN**  
**SALEM, MA**

Prepared for:	COMCAST 9 FROEGE ROAD, SUITE 500 WOBURN, MA 01801	Prepared by:	DEWSNAP ENGINEERING ASSOC. LLP 172 Lincoln Avenue - Salem, MA 01906 Tel # (781) 230-0595
Date:	March 14, 2023	Scale:	As Shown
Checked by:	P.A.D. & R.G.C.	PROJECT LOCATION:	2 MARGIN STREET SALEM, MA
Drawn by:	W.A.L.		
Field By:	P.A.D. & R.G.C.		
	Sheet No. 1 of 4		

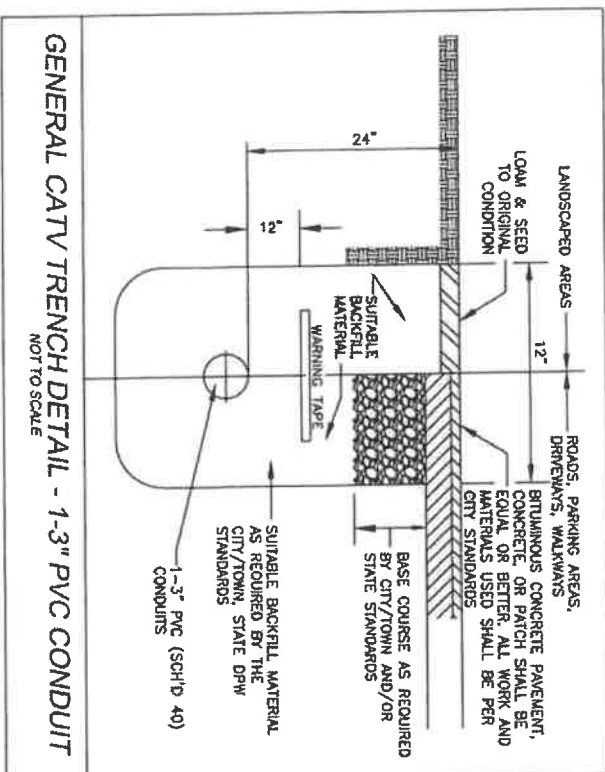
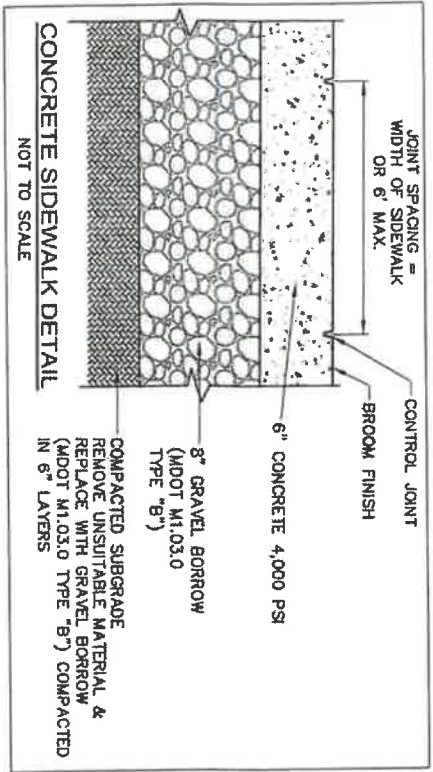

**NOTES:**

1. These plans were prepared from record data on file at the City of Salem Engineering Department and various utility companies. Locations of underground utilities/structures may vary from location hereon and are not warranted to be accurate and/or correct. Additional buried utilities/structures may be encountered. No excavations were performed during the progress of this survey to locate buried utilities/structures.
2. Prior to any construction the Contractor shall notify Dig-SAFE of least 72 hours in advance at 811 (National Call Number) for verification of utilities and for field locations.
3. It is the responsibility of the utility contractor installing the Comcast underground conduit and structures to notify those utility companies not associated with the Dig-SAFE system to verify the locations of their respective utilities. Also, the installing contractor shall be responsible for repairing or replacing any traffic signal loops damaged during the installation of the new Comcast underground conduits and structures.
4. Prior to the start of construction, the Utility Contractor shall confirm the number of conduits and size of the conduits for this project with the Comcast Project Coordinator.
5. These plans were prepared for permitting purposes with the City of Salem, MA. After all utility lines have been marked out in the field the locations of the Proposed Comcast Underground Conduit and Structures may be adjusted to fit with the existing utilities in the field.
6. All work to be performed is for the installation of the New Comcast underground conduit and associated structures.
7. All work shall conform to the approved out-of-hours Engineering and DPW Standards.
8. Upon completion of the trench work for the day, the contractor shall backfill, compact and pave the trench in all roadway and sidewalk areas and the work area shall be broom swept clean. In grassed areas the trench shall be loamed, seeded and hay mulch spread to keep the area stabilized until the grass has taken hold.
9. All concrete sidewalks disturbed or damaged by the placement of the Comcast Underground Conduit shall be repaired/replaced in kind in accordance with the City of Salem Standards and requirements. All Curbing, Signage, Road and Parking striping and traffic signal conduits, wiring or detection loops disturbed during the placement of the Comcast Underground Conduit shall be restored/replaced to their original condition by the Utility Contractor. All property and street line bounds and markers expected to be damaged or disturbed by the placement of the Comcast Underground Conduit shall be located and tied in by a Massachusetts Registered Professional Land Surveyor prior to the work and shall be replaced by the Land Surveyor as part of the project.
10. Street/Property lines are not the result of a boundary survey and are considered to be approximate.

**CONSTRUCTION NOTES:**

1. Following the Dig-Safe "mark out" and field verification of the existing underground utilities, the Proposed 4" PVC, Schedule 40 Comcast Conduit shall be adjusted in the field by the utility contractor to avoid being located over any existing utilities.

**DETAIL NOTES:**

1. The details depicted are for general reference only. The final product used shall be the responsibility of the general contractor and shall be of equal or greater material than that depicted and shall conform to the Engineering/DPW Standards for the City/Town and/or State where the project is located.

THIS PLAN IS DRAWN ON 11" X 17" PAPER.



<b>WARD 2, PRECINCT 2</b>	
<b>PROPOSED COMCAST UNDERGROUND</b>	
<b>ESSEX COUNTY</b>	
<b>PLAN OF LAND</b>	
<b>IN</b>	
<b>SALEM, MA</b>	
Prepared for <b>COMCAST</b> 97 ROGERS ROAD, SUITE 99 WOBURN, MA 01890	Prepared By <b>DEWSNAP ENGINEERING ASSOC. LLP</b> 1751 Lincoln Avenue - Salem, MA 01965 Tel # (781) 233-0585
Date: March 14, 2003	Scale: As Shown
Checked By: P.A.D. & R.G.C.	PROJECT LOCATION: <b>2 MARGIN STREET</b> <b>SALEM, MA</b>
Drawn By: W.A.L.	
Field By: P.A.D. & R.H.	
Sheet No. 2 of 4	





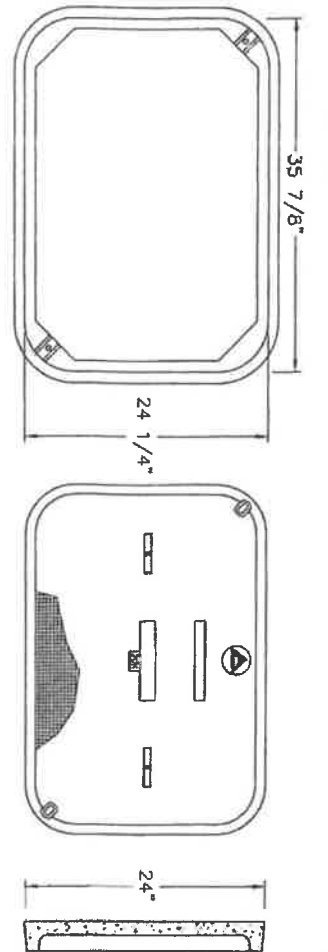

PLAN VIEW

APPROX. WT. = 304 LBS.

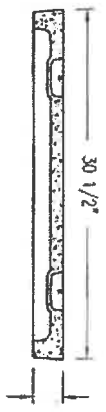

POLYMER CONCRETE COVER

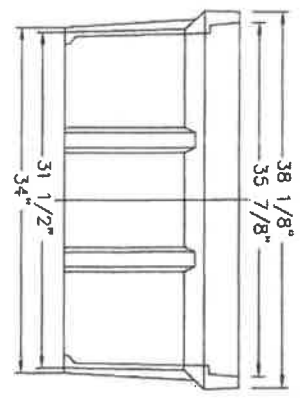

SIDE VIEW

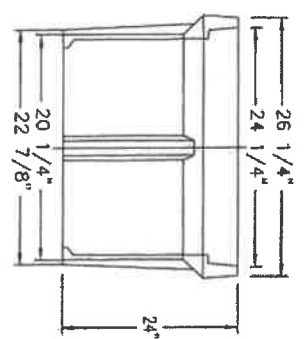

END VIEW

**ARMORCAST 24" X 36" VAULT DETAIL**

NOT TO SCALE

**VAULT NOTES:**

VAULTS SHALL BE AS MANUFACTURED BY ARMORCAST PRODUCTS COMPANY, CHASTWORTH, CA, 24" X 36" X 24" DEEP, TIER 22, 20K LOAD RATED, MODEL #A6001974HDAPCX24.

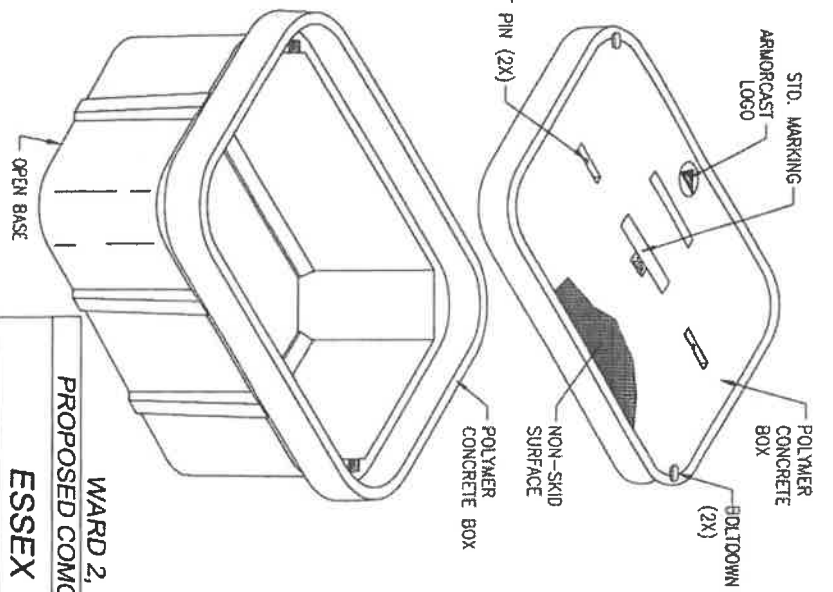

THIS PLAN IS DRAWN ON 11" X 17" PAPER.



<p><b>WARD 2, PRECINCT 2</b>  <b>PROPOSED COMCAST UNDERGROUND</b></p>	
<p><b>ESSEX COUNTY</b></p>	
<p><b>PLAN OF LAND</b>  <b>IN</b>  <b>SALEM, MA</b></p>	
Prepared for:	COMCAST 8 FOSBERG ROAD, SUITE #6 WOBURN, MA 01891
Prepared by:	DEWISNAP ENGINEERING ASSOC. LLP 171 Lincoln Avenue - Salem, MA 01996 Tel # (781) 233-0985
Date:	March 14, 2023
Checked by:	P. A. D. & R. G. C.
Drawn by:	W. A. J.
Field By:	P. A. D. & R. H.
Scale:	As Shown
PROJECT LOCATION:	2 MARGIN STREET SALEM, MA
Sheet No. 4 of 4	

Questions contact – Sibhita Mahabier 781-258-9169

**PETITION FOR JOINT OR IDENTICAL POLE LOCATIONS**

North Andover, Massachusetts

To the City Council  
Of Salem, Massachusetts

Massachusetts Electric Company d/b/a National Grid and Verizon New England, Inc requests permission to locate poles, wires, and fixtures, including the necessary sustaining and protecting fixtures, along and across the following public way:

Grove St - National Grid to Relocate 1 JO Pole on Grove St beginning at a point approximately 130 feet northwest of the centerline of the intersection of Goodhue St and continuing approximately 10' +/- feet in a southeast direction. Relocation of P#556 and all appurtenances 10' +/- southeast of existing location.

Location approximately as shown on plan attached

Wherefore it prays that after due notice and hearing as provided by law, it be granted a location for and permission to erect and maintain poles and wires, together with such sustaining and protecting fixtures as it may find necessary, said poles to be erected substantially in accordance with the plan filed herewith marked – Grove St - Salem – Massachusetts.

No.# 30644184 February 15, 2023

Also for permission to lay and maintain underground laterals, cables, and wires in the above or intersecting public ways for the purpose of making connections with such poles and buildings as each of said petitioners may desire for distributing purposes.

Your petitioner agrees to reserve space for one cross-arm at a suitable point on each of said poles for the fire, police, telephone, and telegraph signal wires belonging to the municipality and used by it exclusively for municipal purposes.

Massachusetts Electric Company d/b/a  
NATIONAL GRID *Bob Coulter*

BY \_\_\_\_\_  
Engineering Department

VERIZON NEW ENGLAND, INC.  
BY \_\_\_\_\_  
Manager / Right of Way

**ORDER FOR JOINT OR IDENTICAL POLE LOCATIONS**

To the City Council - Salem, Massachusetts

Notice having been given and public hearing held, as provided by law,

**IT IS HEREBY ORDERED:**

that Massachusetts Electric Company d/b/a National Grid and VERIZON NEW ENGLAND INC. (formerly known as NEW ENGLAND TELEPHONE AND TELEGRAPH COMPANY) be and they are hereby granted joint or identical locations for and permission to erect and maintain poles and wires to be placed thereon, together with such sustaining and protecting fixtures as said Companies may deem necessary, in the public way or ways hereinafter referred to, as requested in petition of said Companies dated the 15<sup>th</sup> day of February, 2023.

All construction under this order shall be in accordance with the following conditions:

Poles shall be of sound timber, and reasonable straight, and shall be set substantially at the points indicated upon the plan marked – Grove St - Salem – Massachusetts.

February 15, 2023. Filed with this order

There may be attached to said poles by Massachusetts Electric Company d/b/a National Grid and Verizon New England Inc. such wires, cables, and fixtures as needed in their business and all of said wires and cables shall be placed at a height of not less than twenty (20) feet from the ground.

The following are the public ways or part of ways along which the poles above referred to may be erected, and the number of poles which may be erected thereon under this order:

Grove St - National Grid to Relocate 1 JO Pole on Grove St beginning at a point approximately 130 feet northwest of the centerline of the intersection of Goodhue St and continuing approximately 10' +/- feet in a southeast direction. Relocation of P#556 and all appurtenances 10' +/- southeast of existing location.

Also for permission to lay and maintain underground laterals, cables, and wires in the above or intersecting public ways for the purpose of making connections with such poles and buildings as each of said petitioners may desire for distributing purposes.

I hereby certify that the foregoing order was adopted at a meeting of the of the City/Town of \_\_\_\_\_, Massachusetts held on the \_\_\_\_\_ day of \_\_\_\_\_ 20\_\_ .

\_\_\_\_\_  
Massachusetts City/Town Clerk. 20\_\_ .

Received and entered in the records of location orders of the City/Town of  
Book \_\_\_\_\_ Page \_\_\_\_\_

**ORDER FOR JOINT OR IDENTICAL POLE LOCATIONS**

To the City Council - Salem, Massachusetts

Notice having been given and public hearing held, as provided by law,

**IT IS HEREBY ORDERED:**

that Massachusetts Electric Company d/b/a National Grid and VERIZON NEW ENGLAND INC. (formerly known as NEW ENGLAND TELEPHONE AND TELEGRAPH COMPANY) be and they are hereby granted joint or identical locations for and permission to erect and maintain poles and wires to be placed thereon, together with such sustaining and protecting fixtures as said Companies may deem necessary, in the public way or ways hereinafter referred to, as requested in petition of said Companies dated the 15<sup>th</sup> day of February, 2023.

All construction under this order shall be in accordance with the following conditions:

Poles shall be of sound timber, and reasonable straight, and shall be set substantially at the points indicated upon the plan marked - Grove St - Salem - Massachusetts.

February 15, 2023. Filed with this order

There may be attached to said poles by Massachusetts Electric Company d/b/a National Grid and Verizon New England Inc. such wires, cables, and fixtures as needed in their business and all of said wires and cables shall be placed at a height of not less than twenty (20) feet from the ground.

The following are the public ways or part of ways along which the poles above referred to may be erected, and the number of poles which may be erected thereon under this order:

Grove St - National Grid to Relocate 1 JO Pole on Grove St beginning at a point approximately 130 feet northwest of the centerline of the intersection of Goodhue St and continuing approximately 10' +/- feet in a southeast direction. Relocation of P#556 and all appurtenances 10' +/- southeast of existing location.

Also for permission to lay and maintain underground laterals, cables, and wires in the above or intersecting public ways for the purpose of making connections with such poles and buildings as each of said petitioners may desire for distributing purposes.

I hereby certify that the foregoing order was adopted at a meeting of the  
of the City/Town of \_\_\_\_\_, Massachusetts held on the \_\_\_\_\_ day of \_\_\_\_\_ 20 .

\_\_\_\_\_  
Massachusetts City/Town Clerk. 20 .

Received and entered in the records of location orders of the City/Town of  
Book \_\_\_\_\_ Page \_\_\_\_\_

Attest:  
City/Town Clerk

I hereby certify that on \_\_\_\_\_, 20\_\_\_\_, at \_\_\_\_\_ o'clock, M  
at \_\_\_\_\_ a public hearing was held on the petition of  
Massachusetts Electric Company d/b/a National Grid and VERIZON NEW ENGLAND, INC.

for permission to erect the poles, wires, and fixtures described in the order herewith recorded, and that we mailed at least seven days before said hearing a written notice of the time and place of said hearing to each of the owners of real estate (as determined by the last preceding assessment for taxation) along the ways or parts of ways upon which the Company is permitted to erect poles, wires, and fixtures under said order. And that thereupon said order was duly adopted.

City/Town Clerk.

.....  
.....  
.....  
.....

Board or Council of Town or City, Massachusetts

**CERTIFICATE**

I hereby certify that the foregoing is a true copy of the location order and certificate of hearing with notice adopted by the \_\_\_\_\_ of the City of Massachusetts, on the \_\_\_\_\_ day of \_\_\_\_\_, 20\_\_\_\_, and recorded with the records of location orders of the said City, Book \_\_\_\_\_, Page \_\_\_\_\_. This certified copy is made under the provisions of Chapter 166 of General Laws and any additions thereto or amendments thereof.

Attest:  
City/Town Clerk

North

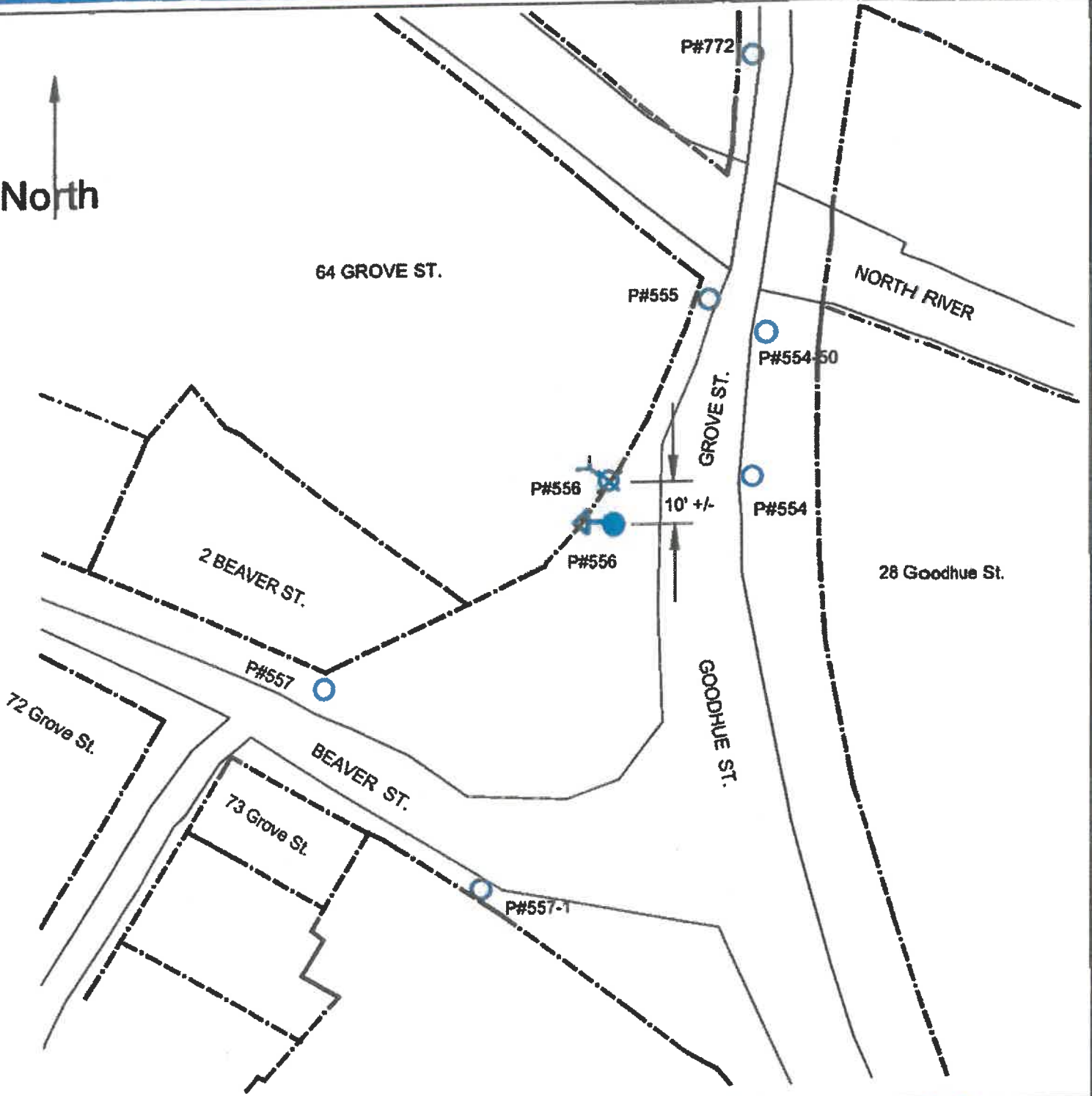

**JOINT OWNED POLE PETITION**

- Proposed JO Pole Locations
- Existing JO Pole Locations
- Proposed NGRID Pole Locations
- Existing J.O. Pole Locations to be Abandoned
- ⚓ Existing Anchor and Guy to be Removed
- ⚓ Proposed Anchor and Guy Location
- Existing Pole Locations To Be Removed

DISTANCES ARE APPROXIMATE

**nationalgrid**  
And  
Verizon New England, Inc.

Date: 02-14-2023

Work Request Number: 12-23-30644184

To Accompany Petition Dated: 02-14-2023

To The: City Of Salem

For Proposed:Relocating Pole:#556 Location: Grove St



Questions contact – Sibhita Mahabier 781-258-9169

Petition of the Massachusetts Electric Company d/b/a National Grid  
Of NORTH ANDOVER, MASSACHUSETTS  
For Electric conduit Location:

To City Council of Salem, Massachusetts

Respectfully represents the Massachusetts Electric Company d/b/a National Grid of North Andover, Massachusetts, that it desires to construct a line of underground electric conduits, including the necessary sustaining and protecting fixtures, under and across the public way or ways hereinafter named.

Wherefore it prays that after due notice and hearing as provided by law, it be granted permission to excavate the public highways and to run and maintain underground electric conduits, together with such sustaining and protecting fixtures as it may find necessary for the transmission of electricity, said underground conduits to be located substantially in accordance with the plan filed herewith marked: Grove St - Salem - Massachusetts.

The following are the streets and highways referred to:

Plan # 30644184 Grove St - National Grid to install beginning at a point approximately 130 feet northwest of the centerline of the intersection of Goodhue St and continuing approximately 10' +/- feet in a southeast direction. Install 10' +/- of 2-5" PVC conduits encased in concrete from P#556 to the property of 64 Grove St.

Location approximately as shown on plan attached

Massachusetts Electric Company d/b/a National Grid  
BY *Bob Coulter*  
Engineering Department

Dated: February 15, 2023

ORDERED:

Notice having been given and public hearing held, as provided by law, that the Massachusetts Electric Company d/b/a National Grid be and it is hereby granted permission to excavate the public highways and to run and maintain underground electric conduits, together with such sustaining and protecting fixtures as said company may deem necessary, in the public way or ways hereinafter referred to, and to make the necessary house connections along said extensions, as requested in petition with said company dated the 15<sup>th</sup> day of February, 2023.

Said underground electric conduits shall be located substantially in accordance with the plan filed herewith marked – Grove St - Salem - Massachusetts. Plan # 30644184.

The following are the public ways or part of ways along which the underground electric conduits above referred to may be laid:

Grove St - National Grid to install beginning at a point approximately 130 feet northwest of the centerline of the intersection of Goodhue St and continuing approximately 10' +/- feet in a southeast direction. Install 10' +/- of 2-5" PVC conduits encased in concrete from P#556 to the property of 64 Grove St.

I hereby certify that the foregoing order was adopted at a meeting of the .....  
.....  
....., held on the ..... day of ....., 20 .....  
....., 20 .....

Received and entered in the records of location orders of the City/Town of  
Book ..... Page .....

Attest:  
.....

..... hereby certify that on .....20....., at ..... o'clock, ....M  
at ....., a public hearing was held on the petition of  
Massachusetts Electric Company d/b/a National Grid for permission to construct the underground  
electric conduits described in the order herewith recorded, and that I mailed at least seven days  
before said hearing a written notice of the time and place of said hearing to each of the owners of  
real estate (as determined by the last preceding assessment for taxation) along the ways or parts of  
ways upon which the Company is permitted to construct the underground electric conduits under  
said order. And that thereupon said order was duly adopted.

.....  
.....  
.....



ORDERED:

Notice having been given and public hearing held, as provided by law, that the Massachusetts Electric Company d/b/a National Grid be and it is hereby granted permission to excavate the public highways and to run and maintain underground electric conduits, together with such sustaining and protecting fixtures as said company may deem necessary, in the public way or ways hereinafter referred to, and to make the necessary house connections along said extensions, as requested in petition with said company dated the 15<sup>th</sup> day of February, 2023.

Said underground electric conduits shall be located substantially in accordance with the plan filed herewith marked – Grove St - Salem - Massachusetts. Plan # 30644184.

The following are the public ways or part of ways along which the underground electric conduits above referred to may be laid:

Grove St - National Grid to install beginning at a point approximately 130 feet northwest of the centerline of the intersection of Goodhue St and continuing approximately 10' +/- feet in a southeast direction. Install 10' +/- of 2-5" PVC conduits encased in concrete from P#556 to the property of 64 Grove St.

I hereby certify that the foregoing order was adopted at a meeting of the .....  
....., held on the ..... day of ....., 20 .....  
....., ....., 20 .....

Received and entered in the records of location orders of the City/Town of  
Book ..... Page .....

Attest:  
.....

..... hereby certify that on .....20....., at ..... o'clock, ....M  
at ....., a public hearing was held on the petition of  
Massachusetts Electric Company d/b/a National Grid for permission to construct the underground  
electric conduits described in the order herewith recorded, and that I mailed at least seven days  
before said hearing a written notice of the time and place of said hearing to each of the owners of  
real estate (as determined by the last preceding assessment for taxation) along the ways or parts of  
ways upon which the Company is permitted to construct the underground electric conduits under  
said order. And that thereupon said order was duly adopted.

.....  
.....  
.....

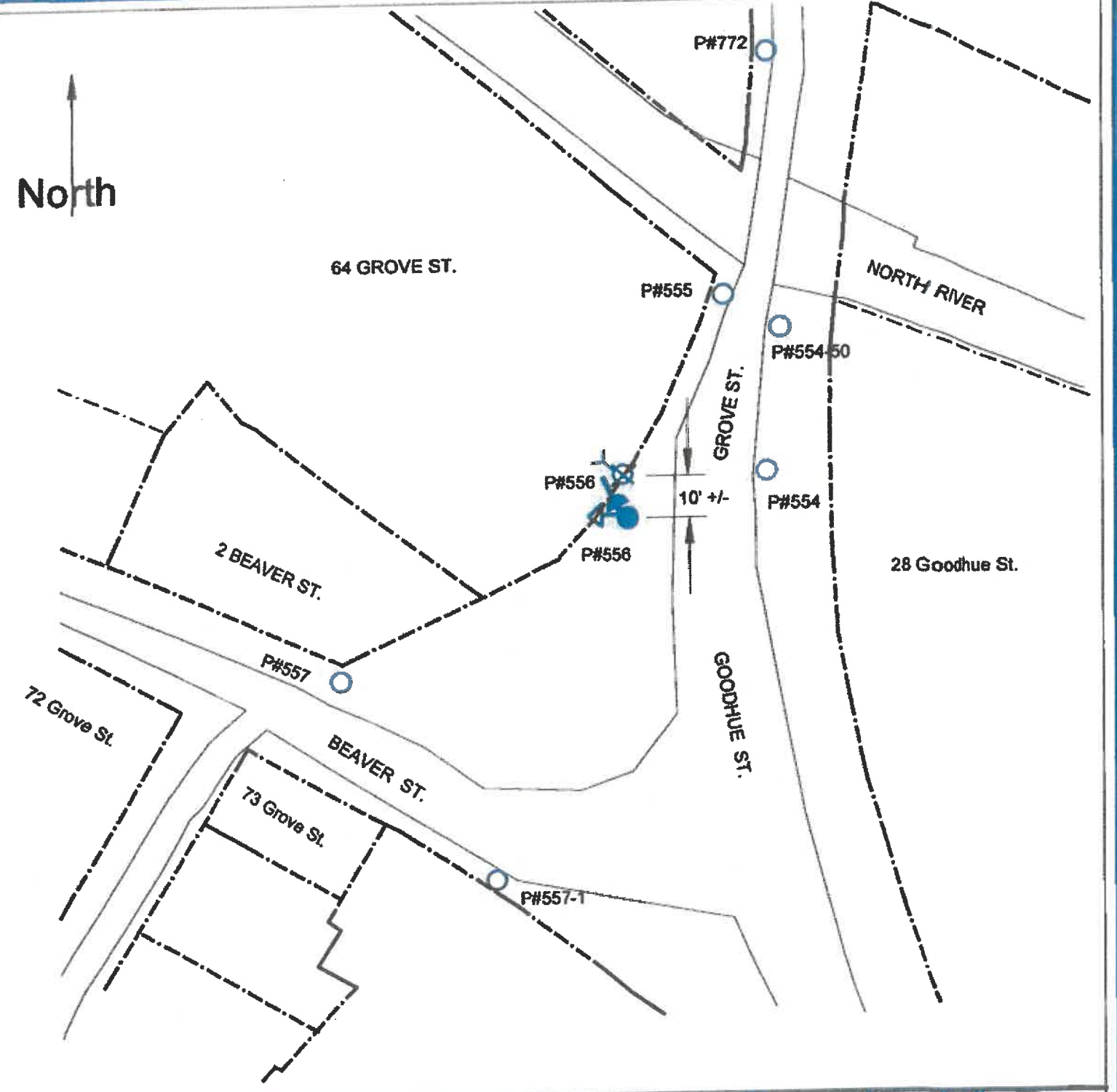

**UNDERGROUND PETITION SKETCH**



- Proposed JO Pole Locations
- Existing JO Pole Locations
- ➔ Proposed Primary Riser
- Proposed 2-5" PVC Conduits Encased in Concrete
- ✂ Existing Anchor and Guy to be Removed
- ⚡ Proposed Anchor and Guy Location
- ☒ Existing Pole Locations To Be Removed

Date: 02-14-2023

Work Request Number: 12-23-30644184

To Accompany Petition Dated: 02-14-2023

To The: City \_\_\_\_\_ Of Salem

For Proposed:

Sketch to accompany petition to install 10' +/- of 2-5" PVC conduits encased in concrete from P# 556 to the Property of 64 Grove St., Salem, MA 01970

DISTANCES ARE APPROXIMATE

Drawn By: Sibhita Mahabier-Sheehy

Questions contact – Sibhita Mahabier 781-258-9169

Petition of the Massachusetts Electric Company d/b/a National Grid  
OF NORTH ANDOVER, MASSACHUSETTS  
For Electric conduit Location:

To City Council of Salem, Massachusetts

Respectfully represents the Massachusetts Electric Company d/b/a National Grid of North Andover, Massachusetts, that it desires to construct a line of underground electric conduits, including the necessary sustaining and protecting fixtures, under and across the public way or ways hereinafter named.

Wherefore it prays that after due notice and hearing as provided by law, it be granted permission to excavate the public highways and to run and maintain underground electric conduits, together with such sustaining and protecting fixtures as it may find necessary for the transmission of electricity, said underground conduits to be located substantially in accordance with the plan filed here with marked: Osborne Hill Dr - Salem - Massachusetts.

The following are the streets and highways referred to:

Plan # 30545052 Osborne Hill Dr - National Grid to install beginning at a point approximately 20 feet northwest of the centerline of the intersection of Amanda Way and continuing approximately 1070 feet in a south/southwestern direction. Installation of 1070' +/- of 2-3" PVC Conduits encased in concrete and all appurtenances in Osborne Hill Dr from Amanda Way to Chanelle Circle.

Location approximately as shown on plan attached

Massachusetts Electric Company d/b/a

NATIONAL GRID *Bob Coulter*

BY \_\_\_\_\_

Engineering Department

Dated: March 9, 2023

ORDERED:

Notice having been given and public hearing held, as provided by law, that the Massachusetts Electric Company d/b/a National Grid be and it is hereby granted permission to excavate the public highways and to run and maintain underground electric conduits, together with such sustaining and protecting fixtures as said company may deem necessary, in the public way or ways hereinafter referred to, and to make the necessary house connections along said extensions, as requested in petition with said company dated the 9th day of March, 2023.

Said underground electric conduits shall be located substantially in accordance with the plan filed herewith marked – Osborne Hill Dr - Salem - Massachusetts. Plan # 30545052.

The following are the public ways or part of ways along which the underground electric conduits above referred to may be laid:

Osborne Hill Dr - National Grid to install beginning at a point approximately 20 feet northwest of the centerline of the intersection of Amanda Way and continuing approximately 1070 feet in a south/southwestern direction. Installation of 1070' +/- of 2-3" PVC Conduits encased in concrete and all appurtenances in Osborne Hill Dr from Amanda Way to Chanelle Circle.

I hereby certify that the foregoing order was adopted at a meeting of the .....  
.....  
....., held on the ..... day of ....., 20 .....  
....., 20 .....

Received and entered in the records of location orders of the City/Town of  
Book ..... Page .....

Attest:  
.....

..... hereby certify that on .....20....., at ..... o'clock, ....M  
at ....., a public hearing was held on the petition of  
Massachusetts Electric Company d/b/a National Grid for permission to construct the underground  
electric conduits described in the order herewith recorded, and that I mailed at least seven days  
before said hearing a written notice of the time and place of said hearing to each of the owners of  
real estate (as determined by the last preceding assessment for taxation) along the ways or parts of  
ways upon which the Company is permitted to construct the underground electric conduits under  
said order. And that thereupon said order was duly adopted.

.....  
.....  
.....

ORDERED:

Notice having been given and public hearing held, as provided by law, that the Massachusetts Electric Company d/b/a National Grid be and it is hereby granted permission to excavate the public highways and to run and maintain underground electric conduits, together with such sustaining and protecting fixtures as said company may deem necessary, in the public way or ways hereinafter referred to, and to make the necessary house connections along said extensions, as requested in petition with said company dated the 9th day of March, 2023.

Said underground electric conduits shall be located substantially in accordance with the plan filed herewith marked – Osborne Hill Dr - Salem - Massachusetts. Plan # 30545052.

The following are the public ways or part of ways along which the underground electric conduits above referred to may be laid:

Osborne Hill Dr - National Grid to install beginning at a point approximately 20 feet northwest of the centerline of the intersection of Amanda Way and continuing approximately 1070 feet in a south/southwestern direction. Installation of 1070' +/- of 2-3" PVC Conduits encased in concrete and all appurtenances in Osborne Hill Dr from Amanda Way to Chanelle Circle.

I hereby certify that the foregoing order was adopted at a meeting of the .....  
.....  
....., held on the ..... day of ....., 20 .....  
....., ..... 20 .....

Received and entered in the records of location orders of the City/Town of  
Book ..... Page .....

Attest:  
.....

..... hereby certify that on .....20....., at ..... o'clock, ....M  
at ....., a public hearing was held on the petition of  
Massachusetts Electric Company d/b/a National Grid for permission to construct the underground  
electric conduits described in the order herewith recorded, and that I mailed at least seven days  
before said hearing a written notice of the time and place of said hearing to each of the owners of  
real estate (as determined by the last preceding assessment for taxation) along the ways or parts of  
ways upon which the Company is permitted to construct the underground electric conduits under  
said order. And that thereupon said order was duly adopted.

.....  
.....  
.....

AMAMNDA WAY







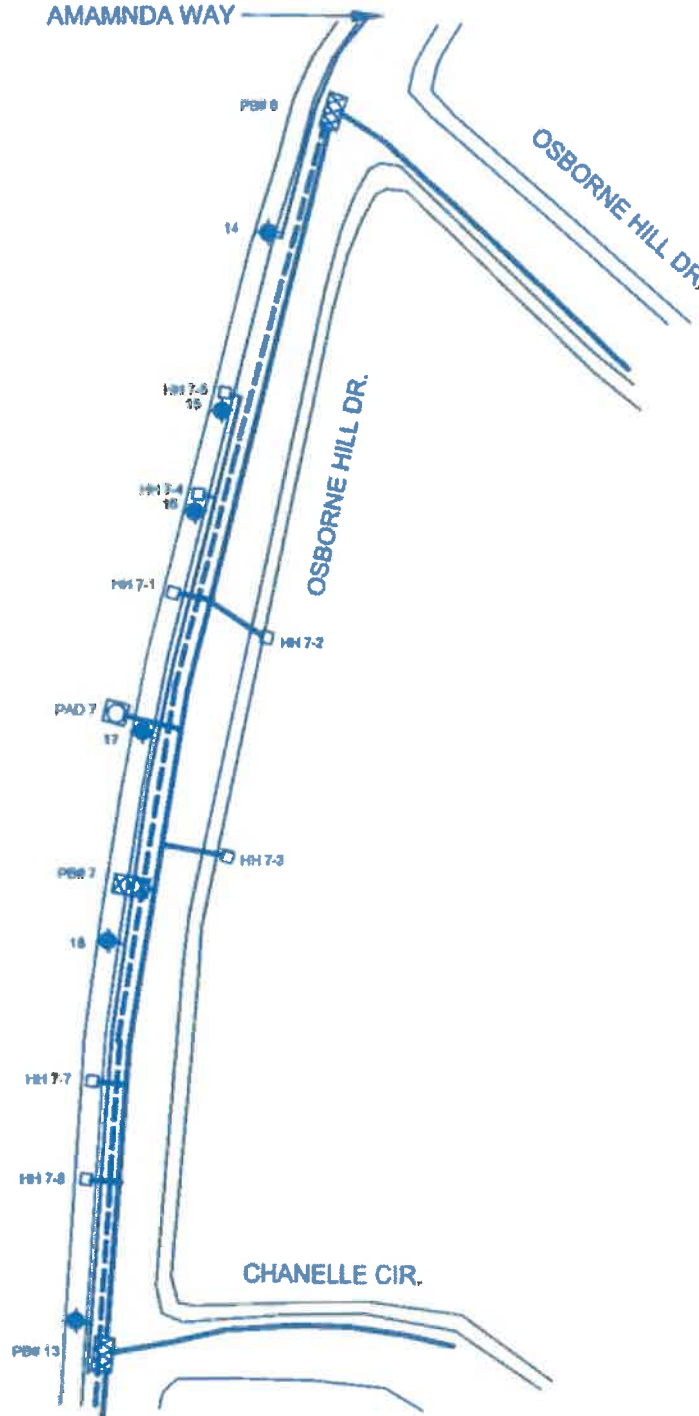

OSBORNE HILL DR.

OSBORNE HILL DR.

CHANELLE CIR.



### UNDERGROUND PETITION

-  STREET LIGHTS (EXISTING)
-  PAD TRANSFORMER (EXISTING)
-  HANDHOLE (EXISTING)
-  EDGE OF STREET
-  PROPOSED CONDUIT 2-3"
-  STREET LIGHT CONDUITS & WIRE (EXISTING)
-  PRIMARY PULL BOX (EXISTING)

# nationalgrid

Sketch to Accompany Petition for the installation of 1070' +/- of 2-3" PVC Conduits from PB# 6 to PB# 13 in Osborne Hill Dr., Salem, MA 01970.

Date: 03-07-2023

WORK REQUEST: 12-22-30545052

To The: City Of Salem

For Proposed: 2-3" Conduit Encased in Concrete Location: Osborne Hill Dr.

DISTANCES ARE APPROXIMATE

Drawn By: Sibhita Mahabier-Sheehy

To: Salem City Council  
Fr: David Potter (owner of On The Grind Café, LLC)  
Re: On The Grind Café opening hours  
Date: 3/16/2030

Dear Council, please allow public hearings to be held to entertain my request to allow On The Grind Café, a coffee shop located at 36 Jefferson Ave, Salem, Ma. to open at 5:00 AM Monday through Sunday.

The current hours (under request at the Salem Licensing Office) are 6:00 AM to 7:00 PM.  
The company that owns the coffee shop is On The Grind Café, LLC, with a Salem address of 36 Jefferson Ave, Salem, Ma. and a legal office at 11 Linden Ave, Swampscott, Ma. 01907.  
I am the owner, David Potter, living at 11 Linden Ave, Swampscott, Ma 01907.  
I can be reached at 781-389-8641 and my e-mail is [dave@davepotter.com](mailto:dave@davepotter.com)

Thank you,



Dave Potter

PAID  
3/21/23  
upl





City Clerk's Office  
Attn: Council President Megan Stott  
Salem City Hall  
93 Washington Street  
Salem, MA 01970

Cc: Ward 2 Councillor, Caroline Watson-Felt

March 15, 2023

Dear Councillor Stott,

**Executive Director**

Kylie Sullivan

**Steering Committee**

**John Andrews**  
Creative Collective  
**Beth Debski**  
Salem Partnership  
**Gina Flynn**  
Eastern Bank  
**Kate Fox**  
Destination Salem  
**Carol McLaughlin**  
Design Committee Chair  
**Linda Mullen**  
Grace & Diggs  
**Rinus Oosthoek**  
Salem Chamber of Commerce  
**Mira Riggin**  
LEAP for Education  
**Jill Thompson Beach**

Salem Main Streets respectfully requests permission to close Front Street as well as Essex Street from New Liberty Street to Hawthorne Boulevard to vehicular traffic during the Salem Arts Festival on Saturday, June 3 and Sunday, June 4 from 8:00 a.m. to 7:00 p.m. We also ask to close the Front Street parking lot and Houdini Way between Front Street and the Klop Alley parking lot for safety and programming purposes. The Salem Arts Festival, a Salem Main Streets project in partnership with the Creative Collective, is a free, family-friendly festival celebrating the arts and includes an art show in Old Town Hall, a street fair, live performances, and collaborative art-making activities.

The majority of our activities will take place in Derby Square, Front Street, and Artists' Row, with a new acoustic stage at Armory Park (with permission from the Peabody Essex Museum) and additional artisan vendors on Essex Street. Closing the streets allows us to increase performance activity and street fair vendors without worrying about crowds crossing the street safely (with good weather, we can see 8,000+ visitors over the course of the weekend). It also typically increases foot traffic to the storefronts along the road closures.

We will be reaching out to Front Street businesses in April to discuss ways to ensure that the increased foot traffic from the festival continues benefitting them as intended, as well as communication to impacted residents. As this is the first year we have considered closing this stretch of Essex Street, we plan to be in contact with all abutters in advance of the council meeting on March 23.

If our proposal is approved, we will again work with the Police and Fire departments to implement any security measures that they recommend. We will be sure to secure the appropriate approvals from Licensing for the festival weekend.

Thank you for your consideration of this request. If you have any questions or concerns, please contact me at (978)744-0004 x115 or via email at [kylie@salemmainstreets.org](mailto:kylie@salemmainstreets.org).

Sincerely,

Kylie Sullivan  
Executive Director, Salem Main Streets



Monday, March 13, 2013

Our city needs to be more cost efficient and friendly to its downtown residents

This ticket could be easily prevented by placing residents who are mandated to have a yearly resident sticker be placed on an e-mail list by month of sticker expiration & be reminded by email at the beginning of the month prior.

Save the cost of paying a meter (maid) person \$25 an hour to walk all the way down Federal St

Save a hearing officer time

Be more resident friendly and cost effective efficient.

Thank You

Lucy Sprague

lucysprague47@yahoo.com

# City of Salem

## Parking Receipt

DATE 3/13/13

RECEIVED RTN

TOTAL \$5.00

CASH  CHECK

Res. Sticker Expires 3/31/2014

# PARKING VIOLATION

**CITY OF SALEM**  
 OFFICE OF THE PARKING CLERK  
 P.O. BOX 27  
 HOPEDALE, MA 01747

TICKET NUMBER	370114580	ISSUE DATE / TIME	03/10/23 12:10
STATE	MA	REGISTRATION	694ZB8
REG. TYPE	PAN	PLATE COLOR	R
VEHICLE MAKE	TOYT	VEHICLE COLOR	SILVE
METER NUMBER		LOCATION	MONROE ST
VIOLATION	18	VIOLATION DESCRIPTION	RESIDENT PERMIT AREA TOW ZONE
NOTES OR COMMENTS			

PERMIT EXPIRED PERMIT PARKING ONLY

AMOUNT DUE	\$15.00
------------	---------

SEE REVERSE SIDE FOR PAYMENT AND / OR APPEAL INSTRUCTIONS.

**FAILURE TO OBEY THIS NOTICE WITHIN 21 DAYS WILL RESULT IN ADDITIONAL FEES AND CAN RESULT IN NON-RENEWAL OF LICENSE AND REGISTRATION.**  
 (MGL CH 90 SEC. 20 A1/2).

BADGE #	505	OFFICER	M.C.
---------	-----	---------	------

# PARKING VIOLATION

CITY CLERK, SALEM MASS.  
 2023 MAR 13 AM 9:43

# City of Salem

---

*In the year Two Thousand and Twenty-three*

**An Ordinance** amending an ordinance relative to sustainable food containers and packaging

*Be it ordained by the City Council of the City of Salem, as follows:*

**SECTION 1.** Chapter 14, Article VIII. – Sustainable Food Containers and Packaging is hereby amended by deleting Sec. 14-515. - Effective date in its entirety and replacing it with the following;

“Sec. 14-515. - Effective date.

This article shall take effect on September 4, 2023.”

**SECTION 2.** This ordinance shall take effect as provided by City Charter.

In City Council March 9, 2023  
Adopted for first passage

ATTEST:

ILENE SIMONS  
CITY CLERK