

To: Salem City Council  
Fr: David Potter (owner of On The Grind Café, LLC)  
Re: On The Grind Café opening hours  
Date: 3/16/2030

Dear Council, please allow public hearings to be held to entertain my request to allow On The Grind Café, a coffee shop located at 36 Jefferson Ave, Salem, Ma. to open at 5:00 AM Monday through Sunday.

The current hours (under request at the Salem Licensing Office) are 6:00 AM to 7:00 PM.  
The company that owns the coffee shop is On The Grind Café, LLC, with a Salem address of 36 Jefferson Ave, Salem, Ma. and a legal office at 11 Linden Ave, Swampscott, Ma. 01907.  
I am the owner, David Potter, living at 11 Linden Ave, Swampscott, Ma 01907.  
I can be reached at 781-389-8641 and my e-mail is [dave@davepotter.com](mailto:dave@davepotter.com)

Thank you,



Dave Potter

PAID  
3/21/23  
upl

**CITY OF SALEM  
CITY COUNCIL  
PUBLIC HEARING**

**THURSDAY, APRIL 13, 2023**

The Salem City Council will conduct a Public Hearing on Thursday April 13, 2023, at 7:00 P.M. in the City Council Chambers, 2<sup>nd</sup> Floor City Hall 93 Washington Street, Salem MA, or Remotely via Zoom (see agenda for Zoom Link) on the request for extended hours of operation for On the Grind Café 36 Jefferson Ave., Salem. The requested extended hours are to be from 5:00 A.M. to 7:00 P.M. to replace the hours of 6:00 A.M. to 7:00 P.M.

**ALL RESIDENTS INVITED**

**ATTEST:**

**ILENE SIMONS  
CITY CLERK**

**Adv: 3/29/23**

**ORDERED:**

Notice having been given and public hearing held, as provided by law, that the Massachusetts Electric Company d/b/a National Grid be and it is hereby granted permission to excavate the public highways and to run and maintain underground electric conduits, together with such sustaining and protecting fixtures as said company may deem necessary, in the public way or ways hereinafter referred to, and to make the necessary house connections along said extensions, as requested in petition with said company dated the 9th day of March, 2023.

Said underground electric conduits shall be located substantially in accordance with the plan filed herewith marked – Osborne Hill Dr - Salem - Massachusetts. Plan # 30545052.

The following are the public ways or part of ways along which the underground electric conduits above referred to may be laid:

Osborne Hill Dr - National Grid to install beginning at a point approximately 20 feet northwest of the centerline of the intersection of Amanda Way and continuing approximately 1070 feet in a south/southwestern direction. Installation of 1070' +/- of 2-3" PVC Conduits encased in concrete and all appurtenances in Osborne Hill Dr from Amanda Way to Chanelle Circle.

I hereby certify that the foregoing order was adopted at a meeting of the .....  
.....  
....., held on the ..... day of ....., 20 .....  
....., 20 .....

Received and entered in the records of location orders of the City/Town of  
Book ..... Page .....

Attest:  
.....

..... hereby certify that on .....20....., at ..... o'clock, ....M  
at ....., a public hearing was held on the petition of  
Massachusetts Electric Company d/b/a National Grid for permission to construct the underground  
electric conduits described in the order herewith recorded, and that I mailed at least seven days  
before said hearing a written notice of the time and place of said hearing to each of the owners of  
real estate (as determined by the last preceding assessment for taxation) along the ways or parts of  
ways upon which the Company is permitted to construct the underground electric conduits under  
said order. And that thereupon said order was duly adopted.

.....  
.....  
.....

**ORDERED:**

Notice having been given and public hearing held, as provided by law, that the Massachusetts Electric Company d/b/a National Grid be and it is hereby granted permission to excavate the public highways and to run and maintain underground electric conduits, together with such sustaining and protecting fixtures as said company may deem necessary, in the public way or ways hereinafter referred to, and to make the necessary house connections along said extensions, as requested in petition with said company dated the 9th day of March, 2023.

Said underground electric conduits shall be located substantially in accordance with the plan filed herewith marked – Osborne Hill Dr - Salem - Massachusetts. Plan # 30545052.

The following are the public ways or part of ways along which the underground electric conduits above referred to may be laid:

Osborne Hill Dr - National Grid to install beginning at a point approximately 20 feet northwest of the centerline of the intersection of Amanda Way and continuing approximately 1070 feet in a south/southwestern direction. Installation of 1070' +/- of 2-3" PVC Conduits encased in concrete and all appurtenances in Osborne Hill Dr from Amanda Way to Chanelle Circle.

I hereby certify that the foregoing order was adopted at a meeting of the .....  
.....  
....., held on the ..... day of ....., 20 .....  
....., 20 .....

Received and entered in the records of location orders of the City/Town of  
Book ..... Page .....

Attest:  
.....

..... hereby certify that on .....20....., at ..... o'clock, ....M  
at ....., a public hearing was held on the petition of  
Massachusetts Electric Company d/b/a National Grid for permission to construct the underground  
electric conduits described in the order herewith recorded, and that I mailed at least seven days  
before said hearing a written notice of the time and place of said hearing to each of the owners of  
real estate (as determined by the last preceding assessment for taxation) along the ways or parts of  
ways upon which the Company is permitted to construct the underground electric conduits under  
said order. And that thereupon said order was duly adopted.

.....  
.....  
.....

AMAMNDA WAY

OSBORNE HILL DR.

OSBORNE HILL DR.

CHANELLE CIR.

NORTH

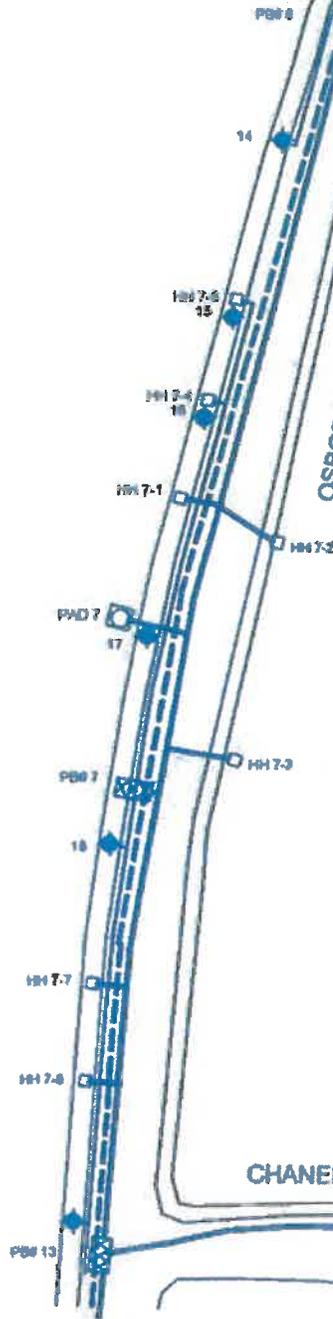

### UNDERGROUND PETITION

- STREET LIGHTS (EXISTING)
- PAD TRANSFORMER (EXISTING)
- HANDHOLE (EXISTING)
- EDGE OF STREET
- PROPOSED CONDUIT 2-3"
- STREET LIGHT CONDUITS & WIRE (EXISTING)
- PRIMARY PULL BOX (EXISTING)

# nationalgrid

Sketch to Accompany Petition for the installation of 1070' +/- of 2-3" PVC Conduits from PB# 6 to PB# 13 in Osborne Hill Dr., Salem, MA 01970.

Date: 03-07-2023

WORK REQUEST: 12-22-30545052

To The: City Of Salem

For Proposed: 2-3" Conduit Encased in Concrete Location: Osborne Hill Dr.

DISTANCES ARE APPROXIMATE

Drawn By: Sibhita Mahabier-Sheehy

ORDERED:

Notice having been given and public hearing held, as provided by law, that the Massachusetts Electric Company d/b/a National Grid be and it is hereby granted permission to excavate the public highways and to run and maintain underground electric conduits, together with such sustaining and protecting fixtures as said company may deem necessary, in the public way or ways hereinafter referred to, and to make the necessary house connections along said extensions, as requested in petition with said company dated the 15<sup>th</sup> day of February, 2023.

Said underground electric conduits shall be located substantially in accordance with the plan filed herewith marked – Grove St - Salem - Massachusetts. Plan # 30644184.

The following are the public ways or part of ways along which the underground electric conduits above referred to may be laid:

Grove St - National Grid to install beginning at a point approximately 130 feet northwest of the centerline of the intersection of Goodhue St and continuing approximately 10' +/- feet in a southeast direction. Install 10' +/- of 2-5" PVC conduits encased in concrete from P#556 to the property of 64 Grove St.

I hereby certify that the foregoing order was adopted at a meeting of the .....  
....., held on the ..... day of ....., 20 .....  
....., 20 .....

Received and entered in the records of location orders of the City/Town of  
Book ..... Page .....

Attest:  
.....

..... hereby certify that on .....20....., at ..... o'clock, ....M  
at ....., a public hearing was held on the petition of  
Massachusetts Electric Company d/b/a National Grid for permission to construct the underground  
electric conduits described in the order herewith recorded, and that I mailed at least seven days  
before said hearing a written notice of the time and place of said hearing to each of the owners of  
real estate (as determined by the last preceding assessment for taxation) along the ways or parts of  
ways upon which the Company is permitted to construct the underground electric conduits under  
said order. And that thereupon said order was duly adopted.

.....  
.....  
.....

ORDERED:

Notice having been given and public hearing held, as provided by law, that the Massachusetts Electric Company d/b/a National Grid be and it is hereby granted permission to excavate the public highways and to run and maintain underground electric conduits, together with such sustaining and protecting fixtures as said company may deem necessary, in the public way or ways hereinafter referred to, and to make the necessary house connections along said extensions, as requested in petition with said company dated the 15<sup>th</sup> day of February, 2023.

Said underground electric conduits shall be located substantially in accordance with the plan filed herewith marked – Grove St - Salem - Massachusetts. Plan # 30644184.

The following are the public ways or part of ways along which the underground electric conduits above referred to may be laid:

Grove St - National Grid to install beginning at a point approximately 130 feet northwest of the centerline of the intersection of Goodhue St and continuing approximately 10' +/- feet in a southeast direction. Install 10' +/- of 2-5" PVC conduits encased in concrete from P#556 to the property of 64 Grove St.

I hereby certify that the foregoing order was adopted at a meeting of the .....  
....., held on the ..... day of ....., 20 .....  
....., 20 .....

Received and entered in the records of location orders of the City/Town of  
Book ..... Page .....

Attest:  
.....

..... hereby certify that on .....20....., at ..... o'clock, ....M  
at ....., a public hearing was held on the petition of  
Massachusetts Electric Company d/b/a National Grid for permission to construct the underground  
electric conduits described in the order herewith recorded, and that I mailed at least seven days  
before said hearing a written notice of the time and place of said hearing to each of the owners of  
real estate (as determined by the last preceding assessment for taxation) along the ways or parts of  
ways upon which the Company is permitted to construct the underground electric conduits under  
said order. And that thereupon said order was duly adopted.

.....  
.....  
.....

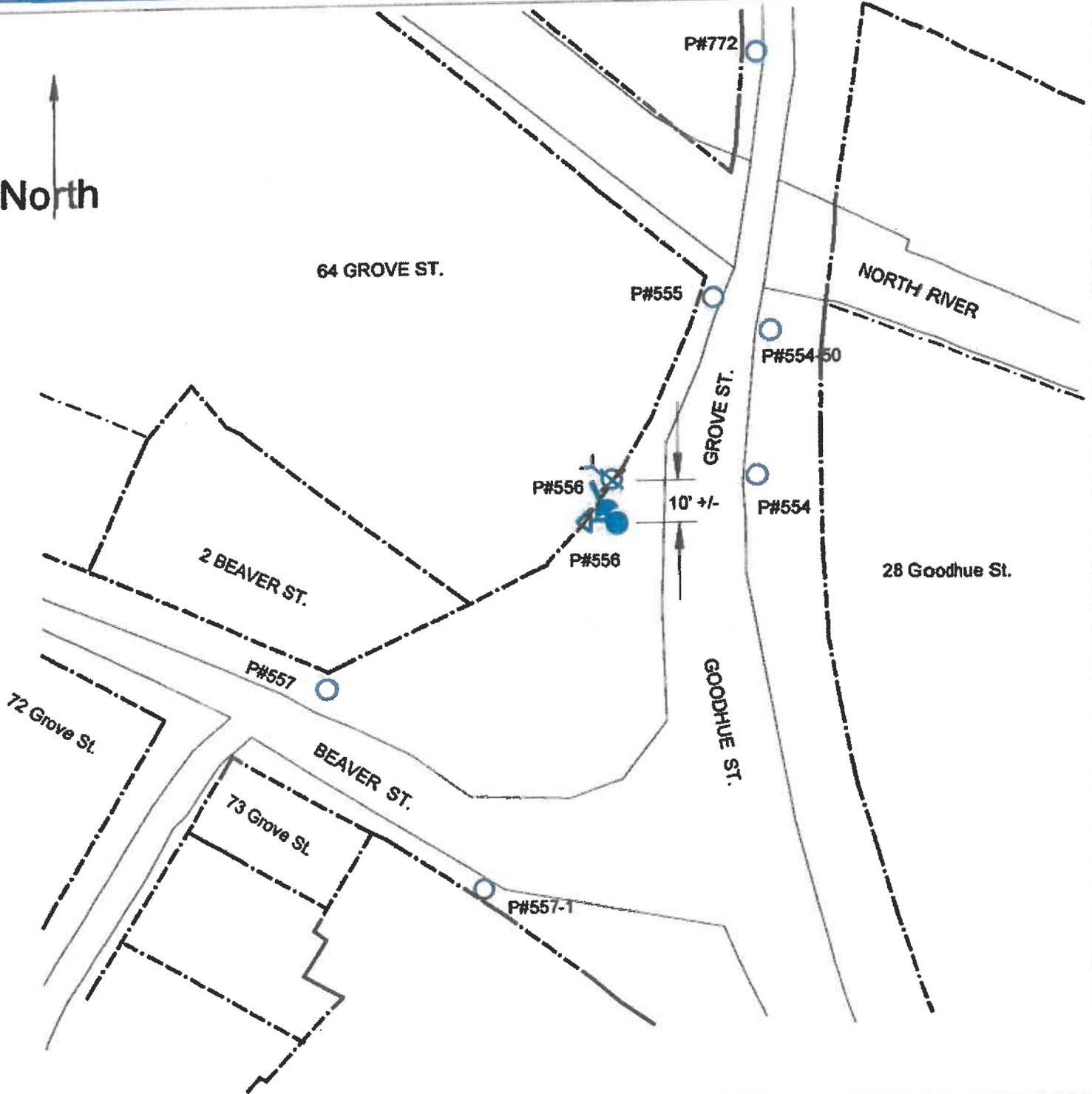

**UNDERGROUND PETITION SKETCH**



- Proposed JO Pole Locations
- Existing JO Pole Locations
- ➔ Proposed Primary Riser
- Proposed 2-5" PVC Conduits Encased in Concrete
- ✂ Existing Anchor and Guy to be Removed
- ⚡ Proposed Anchor and Guy Location
- ⊗ Existing Pole Locations To Be Removed

Date: 02-14-2023

Work Request Number: 12-23-30644184

To Accompany Petition Dated: 02-14-2023

To The: City \_\_\_\_\_ Of Salem

For Proposed:  
 Sketch to accompany petition to install 10' +/- of 2-5" PVC conduits encased in concrete from P# 556 to the Property of 64 Grove St., Salem, MA 01970

Drawn By: Sibhita Mahabier-Sheehy

DISTANCES ARE APPROXIMATE



**ORDER FOR JOINT OR IDENTICAL POLE LOCATIONS**

To the City Council - Salem, Massachusetts

Notice having been given and public hearing held, as provided by law,

**IT IS HEREBY ORDERED:**

that Massachusetts Electric Company d/b/a National Grid and VERIZON NEW ENGLAND INC. (formerly known as NEW ENGLAND TELEPHONE AND TELEGRAPH COMPANY) be and they are hereby granted joint or identical locations for and permission to erect and maintain poles and wires to be placed thereon, together with such sustaining and protecting fixtures as said Companies may deem necessary, in the public way or ways hereinafter referred to, as requested in petition of said Companies dated the 15<sup>th</sup> day of February, 2023.

All construction under this order shall be in accordance with the following conditions:

Poles shall be of sound timber, and reasonable straight, and shall be set substantially at the points indicated upon the plan marked – Grove St - Salem – Massachusetts.

February 15, 2023. Filed with this order

There may be attached to said poles by Massachusetts Electric Company d/b/a National Grid and Verizon New England Inc. such wires, cables, and fixtures as needed in their business and all of said wires and cables shall be placed at a height of not less than twenty (20) feet from the ground.

The following are the public ways or part of ways along which the poles above referred to may be erected, and the number of poles which may be erected thereon under this order:

Grove St - National Grid to Relocate 1 JO Pole on Grove St beginning at a point approximately 130 feet northwest of the centerline of the intersection of Goodhue St and continuing approximately 10' +/- feet in a southeast direction. Relocation of P#556 and all appurtenances 10' +/- southeast of existing location.

Also for permission to lay and maintain underground laterals, cables, and wires in the above or intersecting public ways for the purpose of making connections with such poles and buildings as each of said petitioners may desire for distributing purposes.

I hereby certify that the foregoing order was adopted at a meeting of the  
of the City/Town of \_\_\_\_\_, Massachusetts held on the \_\_\_\_\_ day of \_\_\_\_\_ 20 .

\_\_\_\_\_  
Massachusetts City/Town Clerk. 20 .

Received and entered in the records of location orders of the City/Town of  
Book \_\_\_\_\_ Page \_\_\_\_\_

Attest:  
City/Town Clerk

I hereby certify that on \_\_\_\_\_ 20\_\_\_\_, at \_\_\_\_\_ o'clock, M  
at \_\_\_\_\_ a public hearing was held on the petition of  
Massachusetts Electric Company d/b/a National Grid and VERIZON NEW ENGLAND, INC.

for permission to erect the poles, wires, and fixtures described in the order herewith recorded, and that we mailed at least seven days before said hearing a written notice of the time and place of said hearing to each of the owners of real estate (as determined by the last preceding assessment for taxation) along the ways or parts of ways upon which the Company is permitted to erect poles, wires, and fixtures under said order. And that thereupon said order was duly adopted.

City/Town Clerk.

.....  
.....  
.....  
.....

Board or Council of Town or City, Massachusetts

**CERTIFICATE**

I hereby certify that the foregoing is a true copy of the location order and certificate of hearing with notice adopted by the \_\_\_\_\_ of the City of Massachusetts, on the \_\_\_\_\_ day of \_\_\_\_\_ 20\_\_\_\_, and recorded with the records of location orders of the said City, Book \_\_\_\_\_, Page \_\_\_\_\_. This certified copy is made under the provisions of Chapter 166 of General Laws and any additions thereto or amendments thereof.

Attest:  
City/Town Clerk

**ORDER FOR JOINT OR IDENTICAL POLE LOCATIONS**

To the City Council - Salem, Massachusetts

Notice having been given and public hearing held, as provided by law,  
IT IS HEREBY ORDERED:

that Massachusetts Electric Company d/b/a National Grid and VERIZON NEW ENGLAND INC. (formerly known as NEW ENGLAND TELEPHONE AND TELEGRAPH COMPANY) be and they are hereby granted joint or identical locations for and permission to erect and maintain poles and wires to be placed thereon, together with such sustaining and protecting fixtures as said Companies may deem necessary, in the public way or ways hereinafter referred to, as requested in petition of said Companies dated the 15<sup>th</sup> day of February, 2023.

All construction under this order shall be in accordance with the following conditions:

Poles shall be of sound timber, and reasonable straight, and shall be set substantially at the points indicated upon the plan marked – Grove St - Salem – Massachusetts.

February 15, 2023. Filed with this order

There may be attached to said poles by Massachusetts Electric Company d/b/a National Grid and Verizon New England Inc. such wires, cables, and fixtures as needed in their business and all of said wires and cables shall be placed at a height of not less than twenty (20) feet from the ground.

The following are the public ways or part of ways along which the poles above referred to may be erected, and the number of poles which may be erected thereon under this order:

Grove St - National Grid to Relocate 1 JO Pole on Grove St beginning at a point approximately 130 feet northwest of the centerline of the intersection of Goodhue St and continuing approximately 10' +/- feet in a southeast direction. Relocation of P#556 and all appurtenances 10' +/- southeast of existing location.

Also for permission to lay and maintain underground laterals, cables, and wires in the above or intersecting public ways for the purpose of making connections with such poles and buildings as each of said petitioners may desire for distributing purposes.

I hereby certify that the foregoing order was adopted at a meeting of the  
of the City/Town of \_\_\_\_\_, Massachusetts held on the \_\_\_\_\_ day of \_\_\_\_\_ 20\_\_ .

\_\_\_\_\_  
Massachusetts City/Town Clerk.  
20\_\_ .

Received and entered in the records of location orders of the City/Town of  
Book \_\_\_\_\_ Page \_\_\_\_\_

Attest:  
City/Town Clerk

I hereby certify that on \_\_\_\_\_ 20\_\_\_\_, at \_\_\_\_\_ o'clock, M  
at \_\_\_\_\_ a public hearing was held on the petition of  
Massachusetts Electric Company d/b/a National Grid and VERIZON NEW ENGLAND, INC.

for permission to erect the poles, wires, and fixtures described in the order herewith recorded, and that we mailed at least seven days before said hearing a written notice of the time and place of said hearing to each of the owners of real estate (as determined by the last preceding assessment for taxation) along the ways or parts of ways upon which the Company is permitted to erect poles, wires, and fixtures under said order. And that thereupon said order was duly adopted.

City/Town Clerk.

.....  
.....  
.....  
.....

Board or Council of Town or City, Massachusetts

**CERTIFICATE**

I hereby certify that the foregoing is a true copy of the location order and certificate of hearing with notice adopted by the \_\_\_\_\_ of the City of Massachusetts, on the \_\_\_\_\_ day of \_\_\_\_\_ 20\_\_\_\_, and recorded with the records of location orders of the said City, Book \_\_\_\_\_, Page \_\_\_\_\_. This certified copy is made under the provisions of Chapter 166 of General Laws and any additions thereto or amendments thereof.

Attest:  
City/Town Clerk



64 GROVE ST.

P#772

P#555

NORTH RIVER

P#554-50

P#556

P#556

P#554

28 Goodhue St.

2 BEAVER ST.

10' +/-

GROVE ST.  
GODDUE ST.

P#557

72 Grove St.

BEAVER ST.

73 Grove St.

P#557-1

**JOINT OWNED POLE PETITION**

- Proposed JO Pole Locations
- Existing JO Pole Locations
- Proposed NGRID Pole Locations
- Existing J.O. Pole Locations to be Abandoned
- ⋈ Existing Anchor and Guy to be Removed
- ⋈ Proposed Anchor and Guy Location
- ⊗ Existing Pole Locations To Be Removed

DISTANCES ARE APPROXIMATE

**nationalgrid**

And  
**Verizon New England, Inc.**

Date: 02-14-2023

Work Request Number: 12-23-30644184

To Accompany Petition Dated: 02-14-2023

To The: City Of Salem

For Proposed:Relocating Pole:#556 Location: Grove St

ORDER FOR CONDUIT & POLE LOCATION

In the City Council for the City of Salem, Massachusetts.

ORDERED:

That permission be and hereby is granted to Comcast Cable Communications Management LCC., to lay and maintain underground conduits, manholes and poles, with the wires and cables to be placed therein, under and above the surface of the following public way or ways as requested in petition of said Company dated March 14,2023

Norman Street: Locating the existing Comcast Conduit on Norman Street and placing a proposed 3'x3' manhole. Continuing from the newly placed manhole excavating in a southerly direction to place (1) 3" PVC Conduit 48'+/- to a proposed 17"x 30" vault located in the sidewalk to provide the Comcast Service to number 2 Margin Street.

Substantially as shown on plan, filed with said petition.

Also that permission be and hereby is granted said Comcast to lay and maintain underground conduits, manholes, cables and wires in the above or intersecting public ways for the purpose of making connections with such poles and buildings as it may desire for distributing purposes.

The foregoing permission is subject to the following conditions:

1. The conduits and manholes shall be of such materials and construction and all work done in such manner as to be satisfactory to the City Council or to such officers as it may appoint to the supervision of the work.
2. Said Company shall indemnify and save the City harmless against all damages, costs and expense whatsoever to which the City may be subjected in consequence of the acts or neglect of said Company, its agents or servants, or in any manner arising from the rights and privileges granted it by the City.
3. In addition said Company shall, before a public way is disturbed for the laying of its wire or conduits, execute its bond in a penal sum of Fifty Thousand Dollars (\$50,000) (reference being had to the bond already on file with said City) conditioned for the faithful performance of its duties under this permit.
4. Said Company shall comply with the requirements of existing by-laws and such as may hereafter be adopted governing the construction and maintenance of conduits and wires, so far as the same are not inconsistent with the laws of the Commonwealth.

I hereby certify that the foregoing order was adopted at a meeting of the City Council for the City of Salem, Massachusetts, held on the \_\_\_\_\_ day of \_\_\_\_\_ 2023.

(over)

\_\_\_\_\_  
City Clerk

We hereby certify that on \_\_\_\_\_, 2023, at \_\_\_\_\_ o'clock M., at Salem, Massachusetts a public hearing was held on the petition of the Comcast for permission to lay and maintain underground conduits, manholes and connections, with the wires and cables to be placed therein, described in the order herewith recorded, that we mailed at least seven days before said hearing a written notice the time and place of said hearing to each of the owners of real estate determined by the last preceding assessment for taxation along the ways parts of ways upon which the Company is permitted to construct the lines said Company under said order. And that thereupon said order was duly adopted.

\_\_\_\_\_  
\_\_\_\_\_  
\_\_\_\_\_  
\_\_\_\_\_  
\_\_\_\_\_

Salem City Council; Salem, Massachusetts

CERTIFICATE

I hereby certify that the foregoing is a true copy of a location order, and certificate of hearing with the notice adopted by the City Council for the City of Salem, Massachusetts, on the \_\_\_\_\_ day of \_\_\_\_\_ 2023, recorded with the records of location orders of said City, Book \_\_\_\_\_, Page \_\_\_\_\_. This certified copy is made under the provision of Chapter 166 of General Laws and any additions thereto or amendments thereof.

Attest:

\_\_\_\_\_  
City Clerk





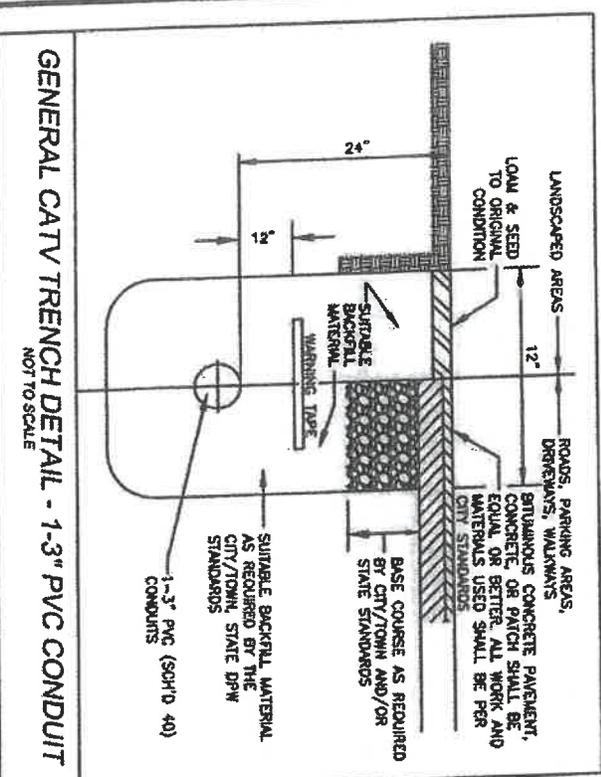
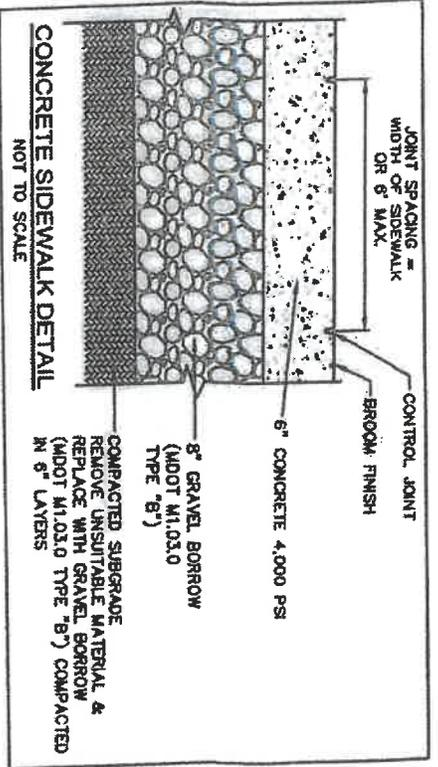

GENERAL CATV TRENCH DETAIL - 1-3" PVC CONDUIT  
NOT TO SCALE

**NOTES:**

1. These plans were prepared from record data on file at the City of Salem Engineering Department and various utility companies. The locations of underground utilities shown are based on the above referenced data. Locations of underground utilities/structures may vary from location hereon and are not warranted to be accurate and/or correct. Additional buried utilities/structures may be encountered. No excavations were performed during the progress of this survey to locate buried utilities/structures.
2. Prior to any construction the Contractor shall notify Dig-SAFE at least 72 hours in advance at 811 (National Call Number) for verification of utilities and for field locations.
3. It is the responsibility of the utility contractor installing the Comcast underground conduit and structures to notify those utility companies not associated with the Dig-SAFE system to verify the locations of their respective utilities. Also, the installing contractor shall be responsible for reporting or notifying any traffic signal loops damaged during the installation of the new Comcast underground conduits and structures.
4. Prior to the start of construction, the Utility Contractor shall confirm the number of conduits and size of the conduits for this project with the Comcast Project Coordinator.
5. These plans were prepared for permitting purposes with the City of Salem, MA. After all utility lines have been marked out in the field the locations of the Proposed Comcast Underground Conduit and Structures may be adjusted to fit with the existing structures in the field.
6. All work to be performed is for the installation of the New Comcast underground conduit and associated structures.
7. All work shall conform to the applicable authorities Engineering and DPW Standards.
8. Upon completion of the trench work for the day, the contractor shall backfill, compact and pave the trench in all roadway and sidewalk areas and the work area shall be broom swept clean. In grassed areas the trench shall be loamed, seeded and hay mulch spread to keep the area stabilized until the grass has taken hold.
9. All concrete sidewalks disturbed or damaged by the placement of the Comcast Underground Conduit shall be repaired/replaced in kind in accordance with the City of Salem Standards and requirements. All Curbing, Signage, Road and Parking striping and traffic signal conduits, wiring or detection loops disturbed during the placement of the Comcast Underground Conduit shall be restored/replaced to their original condition by the Utility Contractor. All property and street line bounds and markers expected to be damaged or disturbed by the placement of the Comcast Underground Conduit shall be located and laid in by a Massachusetts Registered Professional Land Surveyor prior to the work and shall be replaced by the Land Surveyor as part of the project.
10. Street/Property lines are not the result of a boundary survey and are considered to be approximate.

**CONSTRUCTION NOTES:**

1. Following the Dig-Safe "mark out" and field verification of the existing underground utilities, the Proposed 4" PVC, Schedule 40 Comcast Conduit shall be adjusted in the field by the utility contractor to avoid being located over any existing utilities.

**DETAIL NOTES:**

1. The details depicted are for general reference only. The final product used shall be the responsibility of the general contractor and shall be of equal or greater material than that depicted and shall conform to the Engineering/DPW Standards for the City/Town and/or State where the project is located.

THIS PLAN IS DRAWN ON 11" X 17" PAPER.



<b>WARD 2, PRECINCT 2</b>	
<b>PROPOSED COMCAST UNDERGROUND</b>	
<b>ESSEX COUNTY</b>	
<b>PLAN OF LAND</b>	
<b>SALEM, MA</b>	
Prepared for	COMCAST 37 ROGERS ROAD, SUITE 88 WOBURN, MA 01891
Prepared By	DEMSNAP ENGINEERING ASSOC. LLP 170 Linden Avenue - Salem, MA 01970 Tel # (781) 233-0555
Date:	March 14, 2023
Checked By:	P.A.D. & R.G.C.
Drawn By:	W.A.L.
Field By:	P.A.D. & R.H.
Scale:	As Shown
PROJECT LOCATION:	2 MARGIN STREET SALEM, MA
Sheet No. 2 of 4	

- NOTES:**
1. CONCRETE: 5,000 PSI MINIMUM AFTER 28 DAYS.
  2. DESIGN LOADING: AASHTO HS20-44, 0 TO 5 FEET COVER.
  3. STEEL REINFORCEMENT CONFORMS TO ASTM A615, GRADE 60.
  4. MINIMUM STEEL COVER 1".
  5. OPTIONAL OPENINGS AVAILABLE BY SPECIAL ORDER.
- SHEA CONCRETE 3 FOOT X 3 FOOT MANHOLE**  
NOT TO SCALE

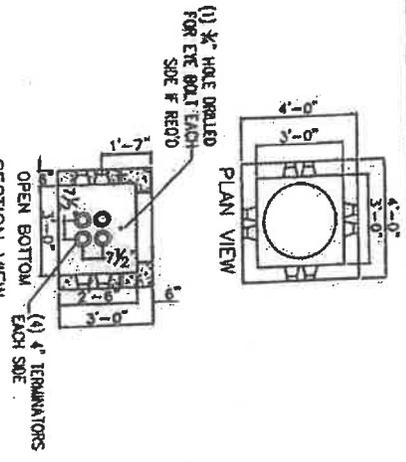

**DETAIL NOTES:**

1. The details depicted are for general reference only. The final product used shall be the responsibility of the general contractor and shall be of equal or greater material than that depicted and shall conform to the Engineering/DPW Standards for the City/Town and/or State where the project is located.

THIS PLAN IS DRAWN ON 11" X 17" PAPER.

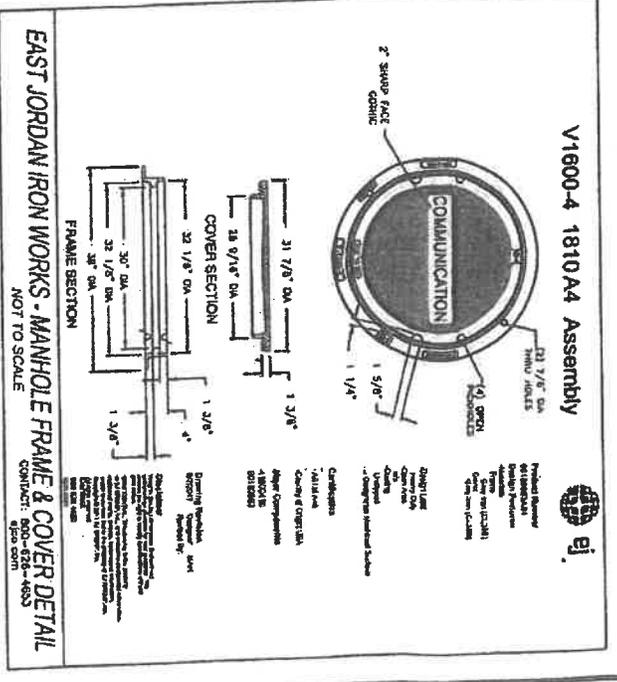

**EAST JORDAN IRON WORKS - MANHOLE FRAME & COVER DETAIL**  
NOT TO SCALE

V1600-4 1810 A4 Assembly



Product Engineer  
East Jordan Iron Works  
178 E. Main Street  
East Jordan, MI 49728  
Tel: (517) 233-4552  
Fax: (517) 233-4553

Drawn By: W.A.J.  
Checked By: P.A.D. & R.G.C.  
Date: March 14, 2023

**WARD 2, PRECINCT 2**  
**PROPOSED COMCAST UNDERGROUND**  
**ESSEX COUNTY**  
**PLAN OF LAND**  
**IN**  
**SALEM, MA**

Prepared for:	COMCAST 9 FOREST ROAD, SUITE 300 WOBURN, MA 01891	Prepared by:	DEWSMAP ENGINEERING ASSOC. LLP 178 E. Main Avenue - Salem, MA 01962 Tel: (781) 733-0392
Drawn By:	W.A.J.	Scale:	As Shown
Checked By:	P.A.D. & R.G.C.	PROJECT LOCATION:	2 MARGIN STREET SALEM, MA
Found By:	P.A.D. & R.H.		
	Sheet No. 3 of 4		

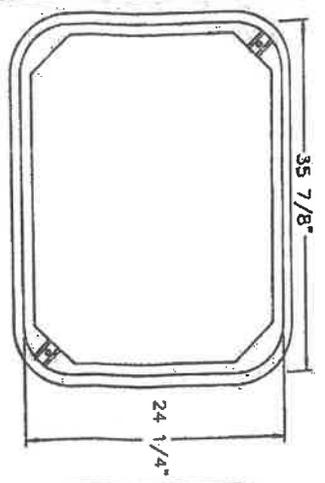

PLAN VIEW

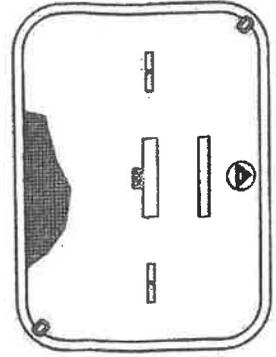

POLYMER CONCRETE COVER

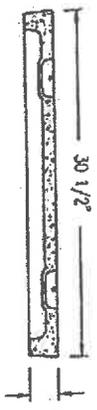

APPROX. WT. = 304 LBS.

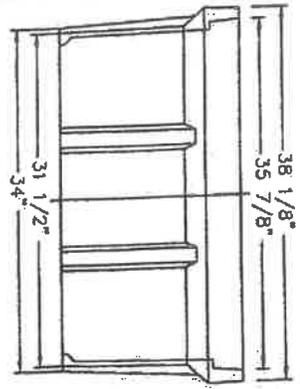

SIDE VIEW

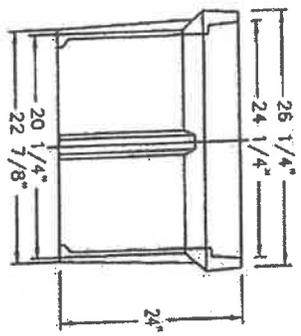

END VIEW

ARMORCAST 24" X 36" VAULT DETAIL

NOT TO SCALE

VAULT NOTES:

VAULTS SHALL BE AS MANUFACTURED BY ARMORCAST PRODUCTS COMPANY, CHASTWORTH, CA, 24" X 36" X 24" DEEP, TIER 22, 20K LOAD RATED, MODEL #A6001974HDAPCX24.

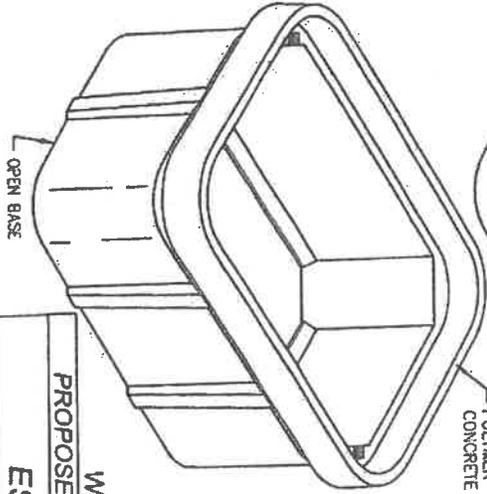
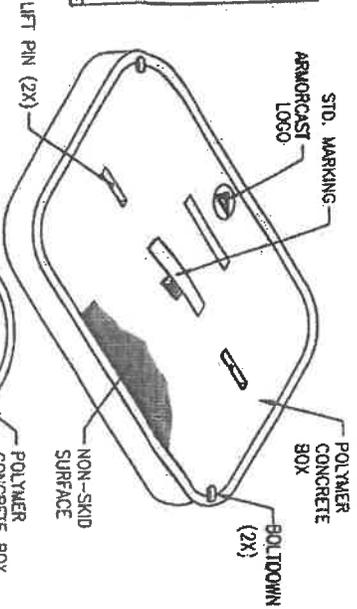

THIS PLAN IS DRAWN ON 11" X 17" PAPER.



<p>WARD 2, PRECINCT 2 PROPOSED COMCAST UNDERGROUND</p>	
<p>ESSEX COUNTY PLAN OF LAND IN SALEM, MA</p>	
<p>Prepared for: COMCAST 9 FOGGESS ROAD, SUITE 99 WOBURN, MA 01897</p>	<p>Prepared by: DEWSNAP ENGINEERING ASSOC. LLP 110 Lowell Avenue, Salem, MA 01970 Tel # (781) 233-0585</p>
<p>Date: March 14, 2023</p>	<p>Scale: As Shown</p>
<p>Checked by: P.A.D. &amp; R.G.C.</p>	<p>PROJECT LOCATION 2 MARGIN STREET SALEM, MA</p>
<p>Drawn by: W.A.J.</p>	
<p>Field by: P.A.D. &amp; R.H.</p>	
<p>Sheet No. 4 of 4</p>	



## **CITY OF SALEM, MASSACHUSETTS**

Robert K. McCarthy

Office of the Mayor

April 13, 2023

Honorable Salem City Council  
Salem City Hall  
Salem, Massachusetts 01970

Ladies and Gentlemen of the City Council:

I am pleased to appoint Phillip Johns of 6 Southwick Street Salem, MA to the Cemetery Commission with a term to expire April 13, 2026.

Mr. Johns is currently a Senior Project Manager for Anser Advisory Company in Boston where he has been involved with architects, contractors, and landscape architects collaborating on design issues and implementation. A 1985 graduate from University of Oklahoma, he possesses a Bachelor of Architecture.

I recommend confirmation of Mr. Johns appointment to the Cemetery Commission. We are fortunate that he is willing to serve our community in this important role and lend his insights and expertise to the Commission and its work.

Very truly yours,

A handwritten signature in blue ink, appearing to read "Robert K. McCarthy", is written over a faint, larger version of the same signature.

Robert K. McCarthy  
Mayor  
City of Salem





**CITY OF SALEM, MASSACHUSETTS**  
Kimberley Driscoll  
Mayor

**Application for Appointment to City Board or Commission**

For a complete list of City boards visit [www.salem.com/boards](http://www.salem.com/boards). Please send this form, along with a current resume, to [mayor@salem.com](mailto:mayor@salem.com) or mail to: Mayor's Office, City Hall, 93 Washington Street, Salem MA 01970.

**Name:** Phillip Johns

**Address:** 6 Southwick St., Salem MA.

**Email:** jamespjohs01@gmail.com

**Daytime Phone:** 617-697-5641

**Evening Phone:** 617-697-5641

**Current occupation:** Project Manager

**Board or commission in which you are interested:** Cemetery Commission

**Why are you interested in serving on this board or commission?**

I have been a resident of Salem for over 8 years and have recently become interested investing some time to the City. I believe that my experience in architecture, design and landscape architecture could be useful to the City of Salem. I have recently been attending more City meetings via Zoom and believe that my experience would be beneficial for some of the various committees.

**In addition to the experience listed in your attached resume, what specific skills or expertise do you believe you can bring to this board or commission?**

As part of my profession I work with architects, contractors and landscape architects on everything from contracts to design issues and implementation. These skills are complimented by my skill in collaborating with the various parties to work through the various challenges encountered during the various stages of project development. This skill at building teams and having them work together towards a common goal is what I would like to be doing for the City of Salem.

**If you are currently serving on any other City boards, please indicate which:**

**Signature:**

*Phillip Johns*

**Date:** 02/22/2023



# Phillip Johns

6 Southwick St.  
Salem, MA. 01970

p. 617-697-5641  
email:jamespjohms01@gmail.com

## Experience

**2018 – Present Ascent/Anser Advisory**  
Senior Project Manager – Owner's Representative

**Boston, MA**

### **Conservation Center – Museum of Fine Arts Boston**

Ascent provided design oversight through project closeout, owner's project management services a new state-of-the-art Conservation Center. The project was comprised of 22,000 square feet of space and six laboratories, the Center featured advanced technology, enhanced opportunities for interdisciplinary collaboration and training, and will establish a Conservation Learning Center. The new Conservation Center consists of laboratories for paintings, objects, frame, and furniture conservation, as well as mount making, exhibition preparation and scientific research.

Responsibilities commenced with the completion of design and extended through construction and project closeout. The project was suspended during the COVID pandemic and was closed out in 2021.

Architect: Sam Anderson Assoc. NYC  
Project Cost: \$29,000,000

### **Alamo Museum and Visitor Center – San Antonio, TX**

As part of the Project Management Team, Ascent together with Broaddus Associates were selected as Program Manager for the Alamo masterplan implementation team. Ascent supported the team in the pricing the conceptual masterplan developed by Machado Silvetti architects and Reed Hilderbrand landscape architects. The Museum/Visitor Center component is currently under reconsideration due to changes in the Masterplan.

### **Polar Park – Worcester, MA.**

Providing owner's representative services for Polar Park the Worcester Sox new baseball facility. Working directly with the team representatives on change management issues.

**2013 – 2018 Peabody Essex Museum (PEM)**  
Senior Project Manager Capital Projects – Owner's Representative

**Salem, MA**

Senior Project Manager for Capital Projects, working closely with the CEO and members of the Executive Leadership Team to develop and implement over \$115M in capital building projects related to the expansion of existing facilities, acquisition of off campus buildings and renovations of existing buildings including historic structures. The core element of the program is the museum expansion project, a 44,000 SF building containing permanent galleries constructed adjacent to the existing museum building complex. Additional off campus program needs were identified for storage of museum collections. The museum Collections Center, a 120,000 SF building, was purchased and renovated for the storage of museum and library collections as well as for associated programmatic needs such as conservation, photography and support areas for staff and public. The Collections Center also includes a public access research room for library collections, which are part of the museum collections. Renovation projects identified with the program also include work to the historic structure, the Phillip's Library. The renovations to the Phillip's Library include new life safety systems, mechanical upgrades, handicapped accessibility, and interior finish improvements. Other campus program elements include the renovations to historic house properties, existing staff offices and retail buildings owned and managed by the museum.

The responsibilities of the Capital Projects Manager include: budget and program development, architect and design team selection and contracting, oversight of the development of design documentation, contractor selection and contracting strategies. All projects are monitored through the completion of construction phase. Feasibility studies and associated budgets were developed for the all the different program elements and evaluated against the overall program budget. Site selection and existing building evaluations were conducted to determine the appropriate implementation strategies for the Collections Center.

Museum Expansion  
Design Architect: Ennead Architects, NYC  
Project Cost: \$72,000,000  
New Construction Area: 44,000 Sq. Ft.

Museum Renovations  
Architect: designLAB, Boston, MA  
Project Cost: \$3,200,000  
Renovations Area: 13,000 Sq. Ft.



Collections Center  
Design Architect: SchwartzSilver Architects, Boston  
Project Cost: \$16,000,000  
Renovations Area: 120,000 Sq. Ft.

Phillips Library  
Architect: SchwartzSilver Architects, Boston  
Project Cost: \$9,000,000  
Renovations Area: 70,000 Sq. Ft.

**2010 – 2013 The Sterling and Francine Clark Art Institute**  
Owner's Representative - Project Manager

**Williamstown, MA**

Project Manager reporting to the Director's Office for the Campus Expansion Project. Primarily responsible for the coordination and communication between project architects, construction managers and the internal museum departments. The Visitor Exhibition & Conference Center (VECC) project included the construction of a new physical plant, special exhibition galleries and visitor amenities (café, retail) and extensive site work to reorient the entry and circulation for the campus. Worked with the Owner's Representative consultants (RISE/Zubatkin) on design and construction issues related to the construction of the VECC and finalization of program, scope and selection of Construction Manager for renovation of the 1955 Museum building and Manton Research Center. Renovation work in the 1955 Museum building included gallery renovations related to the permanent collections and creation of new permanent galleries connecting to the VECC. The renovation of the Manton Research Center provided a new print study room and galleries related the Manton print and works on paper collection.

Design Architect: Visitor Exhibition and Conference Center (VECC): Tadao Ando, Japan  
Project Cost: \$80,000,000  
New Construction Area: 65,000 Sq. Ft.

Design Architect: Museum Building and Manton Research Center: Annabelle Selldorf, New York City, NY  
Project Cost: \$20,000,000  
Renovation Area: 27,000 Sq. Ft.

**2004 – 2010 Museum of Fine Arts (MFA)**  
Owner's Representative - Project Manager

**Boston, MA**

Project Manager reporting to the Project Director of the Project Management Team. Primarily responsible for the coordination and management of project design and construction activities related to gallery re-installation and related fit-out including nine architectural Period Rooms. Working directly with the Art of the Americas curatorial division, Collections Care, Conservation and Exhibitions and Design Departments to develop the programmatic requirements related to the gallery design for 40 permanent galleries, 4 rotating galleries, 4 educational galleries and one Special Exhibition gallery. Permanent galleries in the new American Art Wing contain paintings, sculpture and decorative arts from the Pre Columbian to post World War II period.

- Developed and implemented program approach related to "Visitor Experience" including signage and way finding, ticketing, Special Exhibitions retail shop, coat check, public lobby capacity, flow and accessibility issues.
- Directed and coordinated gallery design process with internal museum departments and Foster + Partners.
- Provided gallery design interface between Foster + Partners, Architect of Record and base building contractor.
- Developed and managed contracting strategy for selection of museum case manufacturer.
- Managed project approvals and permitting processes with the City of Boston and Commonwealth of Massachusetts.
- Facilitated the design implementation and securing of approvals for perimeter site improvements associated with Federal Funding project earmarks.
- Managed the on-site coordination, schedule and budget for Owner's re-installation contractors (Case Manufacturer and Period Rooms).

Design Architect: Foster + Partners, London England  
Project Cost: \$335,000,000  
Base Building Core & Shell Cost: \$210,000,000  
New Construction Area: 213,000 Sq. Ft.  
New Gallery Area: 55,000 Sq. Ft.

**2001 – 2004 Amaze Design, Inc.**  
Senior Project Manager

**Boston, MA**

Responsible for office operations including analysis of project staffing requirements, project budgeting and forecasting. Project management responsibilities included development of consultant contracts with Scope of Work, project schedules and budgeting of project construction costs. Managed client contacts and communication with respect to project budgets and schedule during construction and exhibit installation.

- **Qatar Science Center**  
Doha, Qatar
- **National Children's Museum**  
Washington, D.C.
- **Nantucket Historical Association**  
Nantucket, Massachusetts

**1996 – 2001 Anway & Company Inc.**  
Owner's Representative - Project Manager

**Boston, MA**

- **National Museum of Australia**  
Canberra, Australia  
Exhibition Design Manager responsible for implementation of all exhibit components including; exhibition fabrication, graphic development and multimedia hardware and software. Managed schedule and cost related to exhibition design and construction between base building core and shell and exhibition design. Permanent gallery design (through Design Development) was created in Australia, completed through Construction Documents in the United States and implemented in Australia.

Design Architect: Ashton Raggatt McDougal, Melbourne Australia  
Base Building Core & Shell Cost: \$155,000,000 (AUD)  
New Construction Area: 120,000 Sq. Ft.  
New Gallery Area: 50,000 Sq. Ft.

- **PETROSAINS – Science & Technology Museum**  
PETRONAS Twin Towers Kuala Lumpur, Malaysia  
Assistant Project Manager supporting the Executive Project Manager for the PETROSAINS project. Primary liaison with the owner, providing general oversight of Anway & Company's Kuala Lumpur office. Managed the development and integration of the exhibition design with the base building core and shell architecture including coordination of the building services consultants. Coordinated production and installation of exhibits with fabricators and building contractors.

Total Project Cost: \$70,000,000  
New Construction Area: 100,000 Sq. Ft.  
New Gallery Area: 50,000 Sq. Ft.

## **Education**

**1979–1985 University of Oklahoma**  
Bachelor of Architecture

**Norman, OK**

## **Professional Affiliations**

- Registered Architect  
Commonwealth of Massachusetts
- National Council of Architectural Registration Board (NCARB)  
Board Certified
- Member CMAA  
In process of CCM Certification



## CITY OF SALEM, MASSACHUSETTS

Robert McCarthy

Office of the Mayor

April 13, 2023

Honorable Salem City Council  
Salem City Hall  
Salem, Massachusetts 01970

Ladies and Gentlemen of the City Council:

I am pleased to appoint Charlene Bailey of 7 Pershing Road, Salem, MA to the Beautification Committee for a three-year term to expire April 13, 2026.

Ms. Bailey is retired from the Salem Public Schools as a Business Education Teacher. A 1971 graduate from Boston University, she possesses a master's in education in Administrative/Adult Education and 1966 graduate from Salem State College, she possesses a B.S. in Business Education.

She is currently a member of the Salem Beautification and Traffic Island Team, where she volunteers with gardening, cleaning up and caring for many traffic islands throughout Salem.

I strongly recommend confirmation of Ms. Bailey's appointment to the Beautification Committee. We are fortunate that she is willing to serve our community in this role and lend her expertise, passion, and perspective to the Committee and its work.

Sincerely,

Robert K. McCarthy  
Mayor  
City of Salem



**CHARLENE M. BAILEY**  
7 Pershing Road  
Salem, Massachusetts 01970  
978-430-8798 (cell)

**Overview of Professional Life of My Teaching Career, 1968 - 2001:**

**Massachusetts Certifications:** Business Education K-12  
Instructional Technology Specialist (all levels)  
Principal/Assistant Principal (7-12)  
Supervisor/Director

**Education:** 39 Graduate credits beyond Masters Degree, 1980-1998  
Boston University, 1971, M.Ed in Administration/Adult Education  
Salem State College, Class of 1966, B.S. in Business Education  
Online Courses 2002-03: Creating Web Pages  
Introduction to Windows XP  
Intermediate Microsoft Word  
Microsoft Office Specialist Certification 2004: Word 2000-Core

**Work Experience:** 2001: Retired from Salem Public Schools, Salem, MA  
1966 to 2001: Business Education Teacher, Salem High School; Chandler School  
for Women; Holliston High School.  
1990 – 2001: Head Teacher, Business Education Department, SHS.  
1990 to 2001; Team Member of School-to-Career Initiatives: Tech Prep, High  
Schools That Work, School-to-Work.  
High Schools That Work Coordinator for three years at SHS.  
1986 to 2001: Computer Instructor SHS, taught several 4-12 hour In-service  
computer workshops to staff.  
1985 – 1986: Adjunct Instructor, Fisher Junior College Extension,  
Word Processing I & II courses.  
1985 Spring & Fall 1985: Word Processing Consultant, SHS.  
Developed a curriculum for Word Processing course – taught two Word  
Processing 24-hour courses to Business Education teachers and Salem  
Public School secretaries.

**Activities after Retirement in 2001:**

**2008 to Present:** Volunteer at NEAS (Northeast Animal Shelter) Highland Avenue, Salem, MA  
Volunteer working with dogs: 1-day a week, 4 hours

**2009 to Present:** Salem Beautification Traffic Island Team, gardening, cleaning up and caring for  
many traffic islands throughout Salem. Team is headed by Sandi Power.

Member of SSNA (South Salem Neighborhood Association)

**References:** Available upon request.



**CITY OF SALEM, MASSACHUSETTS**  
Kimberley Driscoll  
Mayor

**Application for Appointment to City Board or Commission**

For a complete list of City boards visit [www.salem.com/boards](http://www.salem.com/boards). Please send this form, along with a current resume, to [mayor@salem.com](mailto:mayor@salem.com) or mail to: Mayor's Office, City Hall, 93 Washington Street, Salem MA 01970.

**Name:** Charlene Bailey

**Address:** 7 Pershing Road, Salem, MA 01970

**Email:** baileyc@comcast.net

**Daytime Phone:** 978-430-8798

**Evening Phone:** 978-430-8798

**Current occupation:** Retired

**Board or commission in which you are interested:** Beautification Committee

**Why are you interested in serving on this board or commission?**

After my retirement, I wanted to spend some of my 'free' time in areas of personal interest while volunteering in areas that would help animals and people. Therefore, I became a volunteer at NEAS (Northeast Animal Shelter) . . . then one morning when I was out walking, I met Sandi Power working at one of the traffic islands; and she explained that she had a team of volunteers who worked on the traffic islands. I decided to join those volunteers, and I have worked as a Traffic Island Volunteer for the past 13 years. I believe that cleanliness in our city, creating gardens through our traffic lanes and maintaining those gardens is very important to our taxpayers, visitors and motorists passing through Salem . . . and the Beautification Committee tackles these issues and many more.

**In addition to the experience listed in your attached resume, what specific skills or expertise do you believe you can bring to this board or commission?**

\* I bring the experience of working on the Traffic Islands for 13 years, working with a team of dedicated volunteers, and we worked with Sandi Power. Currently, there are many member changes on the Beautification Committee and also with the Traffic Island Volunteer Team. I would hope that I could help with these transitions so that we can work together to build the Traffic Island Team in number of volunteers, have a plan for the future so that there is a plan in place that the gardens will be maintained well past the next few years, and work with the city to improve resources to all the gardens.

\* Strong communication skills.

\* Ability to work with a team and individually.

**If you are currently serving on any other City boards, please indicate which:**

No, I am not on a City Board.

(I am a member of the SSNA--South Salem Neighborhood Association.)

**Signature:** *Charlene Bailey*

**Date:** February 6, 2023



**CITY OF SALEM, MASSACHUSETTS**

Robert K. McCarthy

Office of the Mayor

April 13, 2023

Honorable Salem City Council  
Salem City Hall  
Salem, Massachusetts 01970

Ladies and Gentlemen of the City Council:

I am pleased to appoint John (Jack) Butterworth of 14-B Holly Street, Salem, MA to the Affordable Housing Trust Fund Board with a term to expire one year from date of appointment.

Mr. Butterworth is a veteran and a retired newspaper reporter who has served on numerous committees. He is a graduate of Colgate University and possesses a Bachelor of Arts.

I recommend confirmation of Mr. Butterworth appointment to the Affordable Housing Trust Fund Board. We are fortunate that he is willing to serve our community in this important role and lend his insights and expertise to the Affordable Housing Trust Fund Board and its work.

Very truly yours,

Robert K. McCarthy  
Mayor  
City of Salem



**CITY OF SALEM, MASSACHUSETTS**

Kimberley Driscoll

Mayor

**Application for Appointment to City Board or Commission**

For a complete list of City boards visit [www.salem.com/boards](http://www.salem.com/boards). Please send this form, along with a current resume, to [mayor@salem.com](mailto:mayor@salem.com) or mail to: Mayor's Office, City Hall, 93 Washington Street, Salem MA 01970.

Name: John (Jack) Butterworth

Address: 14-B Holly St. Salem MA

Email: jackbutterworth@yahoo.com

Daytime Phone: 978-741-3747

Evening Phone: 978-210-3961  
(preferred)

Current occupation: retired

Board or commission in which you are interested:

Affordable Housing Trust Fund Board

Why are you interested in serving on this board or commission?

I am concerned about the availability of affordable housing in Salem, as a parent and grandparent. I also want to represent ECCO (Essex County Community Organization) on this board.

In addition to the experience listed in your attached resume, what specific skills or expertise do you believe you can bring to this board or commission?

As a former board chairman, I looked for common ground when people disagreed -  
As a former newspaper reporter I learned to read carefully and ask questions about what was and wasn't said.

If you are currently serving on any other City boards, please indicate which:

None

Signature:

John Butterworth

Date: Feb 22,  
2023



## Resume

John (Jack) Butterworth, 14-B Holly Street, Salem MA

Graduated: Belmont High School, Belmont MA 1959  
Colgate University, 1964 (B.A. English)

1964-1967 US Marine Corps Reserve, active duty  
(Studied Russian, Vietnamese)

1967-1968 Transitron, Wakefield MA, wrote instructions for the preparation of  
semi-conductors

1968-1969 Addison-Wesley Publishers, Reading MA edited textbooks, mostly math

1969-1970 CEIR (A division of Control Data) technical writing, instructions for the use  
of computer programs

1970-2012 Lynn Item newspaper reporter

2012-present, retired

## Other experience

1975-1985 President, Friends of the Swampscott Public Library, Elected Town Meeting  
member and Library Trustee, Swampscott MA

1970-present Various years, elected member of the Board of Trustees, also President,  
Vice President and Past President, Unitarian Universalist Church of Greater Lynn,  
Swampscott MA, a church with a \$20 million endowment

2014-Present ECCO volunteer, advocated for use of federal funds for affordable housing



## CITY OF SALEM, MASSACHUSETTS

Robert K. McCarthy  
Acting Mayor

April 13, 2023

Honorable Salem City Council  
Salem City Hall  
Salem, Massachusetts 01970

Ladies and Gentlemen of the City Council:

I am pleased to appoint Hannah Osthoff of 15 Roslyn Street Salem, MA to serve as an alternate on the Zoning Board of Appeals. Ms. Osthoff will complete the remainder of an unexpired three-year term to conclude September 15, 2024. The seat had previously been filled by Nina Vyedin who has been promoted to a member of the Zoning Board of Appeals.

Hannah is a versatile designer who has gained a broad range of experience during her 9+ years in the architecture field. She is passionate about bringing beautiful designs to as many people as possible, which has led her to focus primarily on institutional & commercial projects. During her time at Roger Williams University, Hannah completed a thesis focused on different methods of adaptive reuse and received the AIA Henry Adams Medal.

I strongly recommend confirmation of Ms. Osthoff to the Planning Board. We are fortunate that she is willing to serve our community in this important role and lend her perspective and time to the Board and its work.

Sincerely,

Robert K. McCarthy  
Mayor  
City of Salem



**CITY OF SALEM, MASSACHUSETTS**  
Kimberley Driscoll  
Mayor

**Application for Appointment to City Board or Commission**

For a complete list of City boards visit [www.salem.com/boards](http://www.salem.com/boards). Please send this form, along with a current resume, to [mayor@salem.com](mailto:mayor@salem.com) or mail to: Mayor's Office, City Hall, 93 Washington Street, Salem MA 01970.

**Name:** Hannah Osthoff

**Address:** 15 Roslyn Street, Salem MA, 01970

**Email:** [hosthoff@brunercott.com](mailto:hosthoff@brunercott.com)

**Daytime Phone:** 413-464-1919

**Evening Phone:** 413-464-1919

**Current occupation:** Architect

**Board or commission in which you are interested:** Zoning Board of Appeals

**Why are you interested in serving on this board or commission?**

I have been living in Salem for almost 2 years now, and it is the most exciting, lively and welcoming place I have ever called home. As an architect, I feel that my knowledge and skill set could be of value as a member of the ZBA, which would be a perfect opportunity to better serve my community that I love so much. I also believe this position would help me to become a better, more well-rounded architect.

**In addition to the experience listed in your attached resume, what specific skills or expertise do you believe you can bring to this board or commission?**

My ability to read architectural & construction drawings, past experience with submitting materials for ZBA review, and my understanding of architectural terminology would allow me to adapt quickly to the role, and easily visualize the petitions for review. I have also had a lot of experience with using Zoom, and have participated in similar city review meetings in the past.

**If you are currently serving on any other City boards, please indicate which:**

N/A

**Signature:**

**Date:** 12/5/2022

# HANNAH OSTHOFF, AIA

Registered Architect

- 413.464.1919
- hosthoff855@gmail.com
- 15 Roslyn Street, Salem, MA 01970

Hannah is a versatile designer who has gained a broad range of experience during her 9+ years in the architecture field. She is passionate about bringing beautiful designs to as many people as possible, which has led her to focus primarily on institutional & commercial projects. During her time at Roger Williams University, Hannah completed a thesis focused on different methods of adaptive reuse and received the AIA Henry Adams Medal.

## EDUCATION

### Master of Architecture

Roger Williams University |  
School of Art, Architecture & Historic  
Preservation | 2012

### Bachelor of Science

Roger Williams University |  
SAAHP | 2012

### Study Abroad

Palazzo Rucellai |  
Florence, Italy | 2010

## ACHIEVEMENTS & AWARDS

### Registered Architect

2020 | MA Registration #: 952903

AIA Henry Adams Medal  
Richard Pelletier Memorial Award  
Alpha Chi Honor Society  
Tau Sigma Delta Honor Society  
Second Year Studio Design Award  
Graduated Magna Cum Laude

## HOBBIES & INTERESTS

### Amateur Boxer

Haymakers for Hope Charity Boxing  
Event | 2016, 2017

### Fiber & Paper

Nail & string imagery, macrame,  
weaving, yarn creations, crepe  
paper flower wedding bouquets,  
centerpieces, gift boxes, placecards.

## WORK EXPERIENCE

### Architect | April 2022 - Present

Bruner/Cott Architects | Boston, MA

- Assisting and/or managing project teams through all phases of design, particularly construction administration, with a focus on institutional, academic & commercial projects.
- Coordination with clients, contractors, & consultants.
- Design research, including code review, accessibility audits, and specification information.
- Project design & documentation.

### Architect | April 2015 - April 2022

LDa Architecture & Interiors | Cambridge, MA

- Assisting and/or managing project teams through all phases of design.
- Coordination with clients, contractors, & consultants.
- Assembling & presenting client presentations.
- Design research, including code review, accessibility audits, and specification information.
- Project design & documentation, presentation drawings & renderings.
- Founder/Co-President of the Equitable Practice Committee, Revit Committee coordinator, Lunch & Learn coordinator.

### Architectural Designer | September 2013 - April 2015

Wolf Architects | Boston, MA

- Project management & construction administration
- Client meetings & consultant coordination
- Construction documentation
- Marketing, assembling design award proposals, website design.
- Product research & specifications

## SKILLS

- Revit | 7 Years Professional Experience
- Bluebeam | 7 Years Professional Experience
- Microsoft Suite | 8+ Years Professional Experience
- Photoshop | 8+ Years Professional Experience
- InDesign | 6 Years Professional Experience
- AutoCAD | 2 Years Professional Experience



**CITY OF SALEM, MASSACHUSETTS**

Robert K. McCarthy  
Mayor

April 13, 2023

Honorable Salem City Council  
Salem City Hall  
Salem, Massachusetts 01970

Ladies and Gentlemen of the City Council:

I reappoint, subject to City Council confirmation, the following member of the Board of Registrars of Voters.

First Name	Last Name	Address	Term	Term Expiration
Charles	Barton	26 Marlborough Road	3 years	3/1/2026

I enthusiastically recommend confirmation of his reappointment to Registrars of Voters board and ask that you join me in thanking him for his continued dedicated service and commitment to our community.

Very truly yours,

A handwritten signature in blue ink, appearing to read "Robert K. McCarthy".

Robert K. McCarthy  
Mayor

*City of Salem, Massachusetts*  
*Office of the City Clerk*

*Ilene Simons*  
*City Clerk*



*Room 1*  
*City Hall*

April 5, 2023

Dear Mayor McCarthy:

I respectfully request that my Board of Registrar of Voters member Charles (Chuck) Barton be reappointed for his full term to expire on March 1, 2026. His current term was from February 27, 2020 to March 1, 2023. However, his name was on the Order submitted by Mayor Driscoll during the December 8, 2022 Council Meeting; when she re-appointed board and commission members that were about to expire in the beginning of 2023 with an expiration date of December 31, 2023. (See CO#681 attached)

I spoke to Chuck the night of the election and he wants to be re-appointed for his full three-year term. I support his reappointment for the full 3 years. I will be going into a very busy 2024 election season with both State and Federal Elections. There will be a total of 3 elections with the first one being held in March 5, 2024. I need my complete board to certify nomination papers, petitions and applications. I wish not to face a lapse of time between December 31<sup>st</sup> and the new year.

Thank you for your consideration.

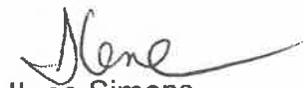
  
Ilene Simons  
City Clerk



## CITY OF SALEM, MASSACHUSETTS

Robert K. McCarthy  
Acting Mayor

April 13, 2023

Honorable Salem City Council  
Salem City Hall  
Salem, Massachusetts 01970

Ladies and Gentlemen of the City Council:

I am pleased to re-appoint Josh Turiel of 238 Lafayette Street to the Salem Planning Board to complete a five-year term to expire on May 24, 2028.

Mr. Turiel served as the Ward 5 City Councillor from 2012 to 2021, including a term as Council President in 2016, a year as Chair of the Community and Economic Development Committee, and five years as Chair of the Administration and Finance Committee. A small business owner, Mr. Turiel has spent the last nearly two decades running his own technology consulting firm supporting small and medium businesses and residential clients, primarily in the Boston and North Shore areas. Prior to that he was the Network Services Manager for Holyoke Mutual Insurance of Salem. Mr. Turiel is a member of the Institute of Electrical and Electronics Engineers and former president of the Greater Boston Network Users Group.

I strongly recommend confirmation of Mr. Turiel to the Planning Board. We are fortunate that he is willing to serve our community in this important role and lend his perspective and time to the Board and its work.

Sincerely,

Robert K. McCarthy  
Mayor  
City of Salem



## **CITY OF SALEM, MASSACHUSETTS**

Robert McCarthy  
Office of the Mayor

April 13, 2023

Honorable Salem City Council  
Salem City Hall  
Salem, Massachusetts 01970

Ladies and Gentlemen of the City Council:

I am pleased to appoint Lucie Juneau Patrowicz of 104 Bay View Avenue Salem, MA to the Recycling Committee. This letter is being provided to you for information purposes only, as City Council confirmation is not required for this committee.

Lucie is a retired copywriter/editor who has previously served on the Recycling committee. A Graduate of Boston University, Boston College, and Drury University.

Please join me in welcoming Lucie to the Recycle Committee. We are fortunate that Lucie is willing to serve the community in this important role and lend expertise and insights to the group and its work.

Sincerely,

Robert K. McCarthy  
Mayor  
City of Salem

CC: Janelle Rolke, City of Salem Waste Reduction Coordinator



## Application for Appointment to City Board or Commission

**Name:** Lucie Juneau Patrowicz

**Address:** 104 Bay View Ave., Salem, MA 01970

**Email:** patrowiczlucie@gmail.com

**Daytime Phone:** 978-836-6401

**Evening Phone:** 978-836-6401

**Current occupation:** Retired copywriter/editor

**Board or commission in which you are interested:** Salem Recycling Committee

### **Why are you interested in serving on this board or commission?**

I have a strong interest in protecting our environment and local ecosystems, including the marine life in Salem Sound. I'd like to support the Committee's work to encourage Salem residents to recycle and to work with the Committee's members to implement and publicize initiatives that will help minimize the negative impacts of waste materials on life in our coastal community.

### **In addition to the experience listed in your attached resume, what specific skills or expertise do you believe you can bring to this board or commission?**

I believe I can apply my significant marketing, writing, and editing experience to help the Committee spread the word about Salem's recycling program and how residents can do their part to pursue greener practices – working to ensure Salem remains a livable, sustainable community for future generations. I've helped create and launch marketing campaigns; developed web site and newsletter content; and written ad and email copy appealing to a wide variety of audiences.

### **If you are currently serving on any other City boards, please indicate which:**

I am not currently serving on any other boards, but I served on the Recycling Committee in the 90s under the direction of Julie Shaw Lutts.

Lucie Juneau Patrowicz  
104 Bay View Ave.  
Salem, MA 01970

**Date:** April 2, 2023

## Lucie Juneau Patrowicz

104 Bay View Ave., Salem, MA 01970  
patrowiczlucie@gmail.com | 978.836.6401

### Objective

To apply my extensive content creation, branding, and editorial skills to benefit an organization with a worthy mission and a collaborative, knowledgeable, and fun-loving team of marketing professionals.

### Experience

**Mintz, Levin, Cohn, Ferris, Glovsky and Popeo, P.C.** July 2010 – June 2022  
Senior Writer

Created engaging website, advertising, and collateral copy for one of Boston's largest law firms. Responsibilities included writing for a wide range of print and electronic formats, reviewing copy written by the firm's attorneys and other writers, writing for and posting to social media, and establishing a consistent editorial style. Served as project manager and primary writer for several of the firm's annual pro bono journals, two of which won first place in the annual report category of LMA New England's Your Honor Awards.

**ResCare, Inc.** 2006 – 2009  
Senior Copywriter

Worked with the vice president of marketing and the creative director to market home care services, programs for individuals with disabilities, and job training programs. Developed website content; created ad campaigns; wrote brochures, press releases, and articles; developed presentations; reviewed the work of junior writers; and coordinated printing services.

**Polese Clancy** 2000 – 2006  
Senior Copywriter

Developed marketing content for this Boston ad agency's clients. Notable projects included creating a 50-page website for MIT's Industrial Liaison Program; writing ads, web copy, collateral, annual reports, and more for Aspen Technology, Inc., a Massachusetts-based software provider; and developing a tagline, ads, and brochure copy that helped Gemini Genomics tell its story and achieve a merger with Sequenom, Inc.

**Freelance Writer and Editor** 1990 – present

Published articles in *Computerworld*, *CIO*, and other journals and magazines. Edited *Patricia: The Pleasure of Her Company*, a book created for the Kennedy family in memory of Patricia Kennedy Lawford. Wrote the marketing content for the 2009 through 2013 Boston Water and Sewer Commission annual reports. Wrote reviews for Larry Stark's *Theater Mirror*. Edited two books on education and wrote a chapter for a high school language arts textbook.

### Other Related Experience

**Endicott College** 1997 – 2000  
Adjunct Professor of English

**Ziff-Davis Publishing Co.** 1987 – 1990  
Staff Editor, *Digital Review*

**Massachusetts Institute of Technology** 1980 – 1987  
Assistant Editor, *MIT Report*  
Editor, *Directory of Current Research*

## **Education**

**Boston University**  
Public Communications Institute

**Boston College**  
M.A. in English

**Drury University**  
B.A. in English and Philosophy, summa cum laude



**CITY OF SALEM, MASSACHUSETTS**

Robert K. McCarthy

Office of the Mayor

April 13, 2023

Honorable Salem City Council  
Salem City Hall  
Salem, Massachusetts 01970

Ladies and Gentlemen of the City Council:

I am pleased to appoint Mari Alix of 16 Thorndike Street, Salem, MA to the Recycling Committee. This letter is being provided to you for informational purposes only, as City Council confirmation is not required for this committee.

Mari has a strong background in analytical thinking and tremendous organizational skills which would be an asset to the Committee. Mari's interest and broad reach in the community will be an asset in combatting climate change by informing residents of the importance of recycling. Mari is a graduate of Salem State University with a master's degree in science and a Boston University graduate with a BA degree.

I recommend confirmation of Mari's appointment to the Recycling Committee. We are fortunate that Mari is willing to serve our community in this important role and lend insights and expertise to the Committee and its work.

Very truly yours,

Robert K. McCarthy  
Mayor  
City of Salem

Cc: Janelle Rolke, City of Salem Waste Reduction Coordinator.



**CITY OF SALEM, MASSACHUSETTS**  
Kimberley Driscoll  
Mayor

**Application for Appointment to City Board or Commission**

For a complete list of City boards visit [www.salem.com/boards](http://www.salem.com/boards). Please send this form, along with a current resume, to [mayor@salem.com](mailto:mayor@salem.com) or mail to: Mayor's Office, City Hall, 93 Washington Street, Salem MA 01970.

Name: Mari Alix

Address: 16 Thoendike St Salem MA 01970

Email: negrita2013@yahoo.com

Daytime Phone: 508-317-0820 Evening Phone: 508-317-0820

Current occupation: Network Security / Real Estate agent

Board or commission in which you are interested: Recycling Committee

Why are you interested in serving on this board or commission?

I would like to help increase awareness in the community as well as help with Spanish translations.

In addition to the experience listed in your attached resume, what specific skills or expertise do you believe you can bring to this board or commission?

I'm bilingual (Spanish/English).

If you are currently serving on any other City boards, please indicate which:

N/A

Signature:

Date: 12/31/22

**MARI ALIX**  
[Negrita2013@yahoo.com](mailto:Negrita2013@yahoo.com)  
508-317-0820

**EDUCATION:**

Salem State University, Salem, MA  
Master of Science  
Criminal Justice Administration and Criminology

Boston University, Boston, MA  
Bachelor of Arts  
Computer Science and Business Administration

**EXPERIENCE:**  
6/18 to present

EOTSS, Chelsea, MA

Network Security Operations

Support all the Commonwealth secretariats and the agencies under them using Checkpoint and Palo Alto security appliances. Establish and maintain access permissions to the different resources in the state network for internal users, outside vendors as well as for all state agencies. Review new security requests for implementation approval or denial. Implement security policies and procedures as specified. Troubleshoot network access issues. Provide technical support for projects. Configure, maintain and manage the secretariat's internet security software, Zscaler. Implement DNS additions and changes. Configure and maintain the state's VPN appliances policies and procedures.

5/01 to 6/18

EOLWD, Boston, MA

Network Security Administrator

Manage the ASA security appliances that support the five agencies under the secretariat. Responsible for establishing and maintaining access permissions to the different resources in the secretariat's network for internal users, outside vendors as well as for other state agencies and career centers. Provide technical support for LAN projects. Act as security liaison with the State Information Technology Department. Implement security policies and procedures as specified. Provide support and firewall data for security investigations. Alert management of possible security breaches. Make configuration changes to the routers and switches to support firewall changes. Serve as network engineer backup by adding, deleting and modifying the configuration of Cisco routers, switches, Nexus or Ace as needed. Configure and maintain the Cisco Firepower Security Appliance to detect intrusion. Configure, maintain and manage the agency's internet security software, Websense. Provide monitoring of user activities that violate usage policies. Create internet usage reports and assist with the analysis of the data during internal policy breach investigations as requested. Served as backup to the Web Administrator, publishing and granting permissions to our production Intranet and Internet servers. Served as backup for Microsoft Exchange.

7/04 to present

Tache Real Estate, Salem, MA

Real Estate Sales Associate

Assist clients with renting, buying, or selling property. Perform market analysis for property listings, interview prospective clients, accompany clients to property site, discuss conditions of sale, and draw up real estate contracts.



**CITY OF SALEM, MASSACHUSETTS**

Robert K. McCarthy

Office of the Mayor

April 13, 2023

Honorable Salem City Council  
Salem City Hall  
Salem, Massachusetts 01970

Ladies and Gentlemen of the City Council:

I am pleased to appoint Catherine Deyo of 18 Turner Street, Salem, MA to the Recycling Committee.

This letter is being provided to you for informational purposes only as City Council confirmation is not required for this committee.

Ms. Deyo has a strong background in critical and logistical thinking and tremendous organizational skills which will be an asset to the Committee. Catherine's observations and ideas on preserving green space and informing residents of the importance of recycling, particularly plastics, is beneficial to the committee. Ms. Deyo is a graduate of Wellesley College with a bachelor's degree in the Arts.

We are fortunate that Ms. Deyo is willing to serve our community in this important role and lend insights and expertise to the Committee and its work.

Very truly yours,

Robert K. McCarthy  
Mayor  
City of Salem



**CITY OF SALEM, MASSACHUSETTS**

Kimberley Driscoll

Mayor

**Application for Appointment to City Board or Commission**

For a complete list of City boards visit [www.salem.com/boards](http://www.salem.com/boards). Please send this form, **along with a current resume**, to [mayor@salem.com](mailto:mayor@salem.com) or mail to: Mayor's Office, City Hall, 93 Washington Street, Salem MA 01970.

Name: Catherine Deyo

Address: 18 Turner St. #2 Salem, MA 01970

Email: cadeyo2608@gmail.com.

Daytime Phone: 978-979-9918

Evening Phone:

Current occupation: retired

Board or commission in which you are interested: Recycling Committee

**Why are you interested in serving on this board or commission?**

I believe that climate change is a reality and that we are at a critical point. I believe that we must be more aggressive and creative with respect to recycling, especially with respect to plastic which is crippling our oceans, and of our garbage, which is overwhelming our lands. I have recycled my entire life - (I collected newspapers and other paper waste from my school in high school). I would like to help.

**In addition to the experience listed in your attached resume, what specific skills or expertise do you believe you can bring to this board or commission?**

I believe that my resume documents my skills and expertise. I am a loyal employee, attentive to detail, an experienced researcher, and an assertive team player.

I am a long term resident and plan to remain in Salem. I am retired and have the time and energy to give back to my community. I have volunteered at Lifebridge for 14 years and at PetSmart (PALS) for 14 years.

If you are currently serving on any other City boards, please indicate which: None

Signature: Catherine D. Deyo

Date: 3/28/23



## CATHERINE A. DEYO

18 Turner St. #2 Salem, MA 01970 978-979-9918 [cadeyo2608@gmail.com](mailto:cadeyo2608@gmail.com)

### GENERAL PARALEGAL QUALIFICATIONS

- Mastery of factual, procedural, technological and practical aspects of supporting attorneys in trial, mediation and arbitration settings in multiple areas of law in state and federal jurisdictions, the American Arbitration Association and the New York Stock Exchange;
- Strong factual research and business writing skills including substantial experience locating, organizing, analyzing and presenting information and data;
- Exceptional organizational, analytical and problem solving skills, ability to prioritize multiple assignments, use judgment to accomplish results, work independently within tight time frames, and produce extremely accurate and detailed work;
- Excellent communication interpersonal, teamwork skills, ability to interact efficiently and effectively with attorneys, management and staff as well as clients, opposing and co-counsels, court personnel, and third party vendors; and
- Demonstrated ability to train and guide, and to plan, delegate, and coordinate responsibilities.

### COMPUTER SKILLS

Microsoft Office; FileSite; Concordance; HighQ; Relativity; LiveNote; ClientCentral and shared drives; Serengeti; varied client databases; Kronos; DTI; ECF, TrialWorks; Chartswap.

### EXPERIENCE and HIGHLIGHTS -all full-time positions

**Paralegal, Mazow | McCullough PC, Salem, MA**

09.2020- 12.2020

Personal Injury Paralegal: independently administered 28 cases; conducted intake and opened new matters; proposed additions to the intake process; communicated on a daily basis with clients, insurance adjusters, state officials and medical providers; created reference documents for medical and insurance contacts and protocols; identified and requested medical and billing records; created medical records indexes; prepared a demand; coordinated the addition of a search function to the master database software.

**Paralegal, Litigation Department: McDermott Will & Emery, LLP, Boston, MA**

10.2016 - 04.2020

- General Litigation Paralegal: assisted with a major breach of contract matter, including more than 15 document productions.
- National Counsel Paralegal: administered and supported in excess of 1500 product liability cases in multiple jurisdictions, including direct client and local counsel contact; prepared quarterly and annual statistical reports; managed multiple document productions; managed relocation and organization of 550 boxes of client documents; selected, recreated and began to populate a client and litigation electronic document repository.
- Pro Bono Experience: assisted with a 7 week federal criminal trial; introduced and coordinated a pro bono opportunity to the office.

**Paralegal Specialist, Litigation Department, Morgan Lewis & Bockius LLP, Boston, MA** 11.2014 – 07.2016

- Products Liability Paralegal: Mastered several versions of a proprietary database; analyzed new matters and continually updated database; performed numerous time-sensitive projects to support national team.
- Temporary Client Secondment: selected to relocate and act as an in-house paralegal, ultimately managing 28 varied cases. Presented selected matters to the Regional Director of Litigation at quarterly meeting.

**Paralegal Specialist**, Litigation Department, Bingham McCutchen LLP, Boston, MA to 11.2014

- Breach of Contract Experience: as a client-approved paralegal, supported numerous matters for major client, including managing all discovery; researching participants; performing general research; fact cite checking pleadings and suggesting edits to client authored submissions; communicating with the client and accessing proprietary and confidential client databases; coordinating with witnesses and experts; maintaining electronic master case files and calendars; assembling and maintaining compilations of law, key documents, pleadings, transcripts and exhibits, as well as background documentation.
- Ponzi Scheme Experience: administered the firm's largest and longest operating ClientSite; provided general support to more than 50 litigations in numerous jurisdictions; assisted with trial preparation.
- Professional Liability Insurance Experience: entrusted to handle multiple, sensitive firm matters.
- Arbitration Experience: responsible for all aspects of the longest running arbitration in the history of the NYSE involving a succession of more than 20 in-house attorneys and innumerable temporary staff, 4 jurisdictions - including the Supreme Court, 42 claimants, more than 59 witnesses and over 4000 exhibits.
- Securities Experience: managed all aspects of numerous matters for varied financial services clients.
- Pro Bono Experience: supported several matters; participated in firm sponsored events; conducted several surveys of all pro bono matters in several offices to determine status, staffing, budgeting and closure statistics.
- Products Liability Experience: supported numerous cases, including a trial; reported directly to the client on a monthly basis; located, requested and tracked medical records and created chronologies; maintained medical reference and pleadings libraries.
- Antitrust and Lemon Law Experience: administered multiple matters and provided general support to the team.
- Litigation Paralegal Coordinator: participated in the hire and review of all full-time paralegals and supervised same; hired and supervised department interns; gave presentation to the Litigation Department on the role and abilities of paralegals; authored two articles for MCLE and presented at MCLE seminars.
- Litigation Department Assistant: coordinated the workflow to associates and the associate review process; maintained the department calendar.
- Campaign Coordinator: Assisted in a campaign for the ABA presidency, including researching ABA members and planning social events.

## **EDUCATION**

B.A. English, Wellesley College

Teaching Certificate Secondary School English

## **AWARDS**

Morgan Lewis & Bockius LLP Excellence in Pro Bono Service Award 2016  
Bank of America, N.A. Litigation Roundtable Summit Recognition 2012



## CITY OF SALEM, MASSACHUSETTS

Robert McCarthy  
Office of the Mayor

April 13, 2023

Honorable Salem City Council  
Salem City Hall  
Salem, Massachusetts 01970

Ladies and Gentlemen of the City Council:

I am pleased to appoint Daniell Hepting of 12 Lemon Street, Salem, MA to the Recycling Committee. This letter is being provided to you for informational purposes only, as City Council confirmation is not required for this committee.

Ms. Hepting is currently a Project manager at 3 Digital QC. A Graduate of Boston University and Simmons College. She has a passion for environmentalism.

Please join me in welcoming Daniell to the Recycle Committee. We are fortunate that she is willing to serve the community in this important role and lend expertise and insights to the group and its work.

Sincerely,

Robert K. McCarthy  
Mayor  
City of Salem

CC: Janelle Rolke, City of Salem Waste Reduction Coordinator



**CITY OF SALEM, MASSACHUSETTS**  
Kimberley Driscoll Mayor

**Application for Appointment to City Board or Commission**

For a complete list of City boards visit [www.salem.com/boards](http://www.salem.com/boards). Please send this form, **along with a current resume**, to [mayor@salem.com](mailto:mayor@salem.com) or mail to: Mayor's Office, City Hall, 93 Washington Street, Salem MA 01970.

**Name:** Daniell Hepting

**Address:** 12 Lemon St., Salem, MA 01970

**Email:** [daniell.hepting@gmail.com](mailto:daniell.hepting@gmail.com)

**Daytime Phone:** 617-913-1546

**Evening Phone:** Same as daytime phone

**Current occupation:** Project Coordinator

**Board or commission in which you are interested:** Recycling Committee

**Why are you interested in serving on this board or commission?**

While working as a marine mammal trainer in San Diego Bay, I saw firsthand the harm that trash (especially plastic trash) caused to the local marine life. I saw numerous sea lions tangled in fishing line, pulled plastic bags out of the mouths of dolphins, and disentangled sea birds from balloons and other plastic items. Since then, I've been working hard to reduce trash in my life and ensure that of the trash I produce, the smallest amount possible winds up in a landfill. Being a part of this committee would allow me to expand those efforts beyond my own home and help our community reduce their landfill bound trash as well.

**In addition to the experience listed in your attached resume, what specific skills or expertise do you believe you can bring to this board or commission?**

I am highly organized, I work well with cross functional teams, I have experience with public speaking, and a passion for environmentalism. I am always seeking to learn more about how to reduce my environmental impact.

**If you are currently serving on any other City boards, please indicate which:** None

**Signature:** Daniell Hepting

**Date:** 29Mar23

**Daniell Hepting**  
12 Lemon St.  
Salem, MA 01970  
617-913-1546  
[daniell.hepting@gmail.com](mailto:daniell.hepting@gmail.com)

### **Interests**

Conservation; Nonprofit Organizations; Environmentalism; Conservation Education; Animal Behavior and Training, Social Media, Communications, Grant Writing; Sustainability

### **Education**

2015 Certificate, Professional Fundraising, Boston University Metropolitan College, Boston, MA

2001 Masters Degree, Social Work, Simmons College School of Social Work, Boston, MA

1998 BA, Psychology, Boston University, Boston, MA

### **Experience**

Jan 2022-Present **Resilience**

#### **Remote**

#### **Project Coordinator – Digital Biomanufacturing Applications**

Project Management of 3 Digital QC Applications Portfolio projects that include a generally available launch and multiple site deployments per project. The projects include Empower for Chromatography Data Systems, Novatek Environmental Monitoring, and LabVantage Laboratory Information Management System (LIMS).

March 2021-Jan 2022 **Resilience**

#### **Allston, MA**

#### **Manufacturing Specialist II**

Project Management, cross functional teamwork, organize and facilitate Events and CAPA meetings, revise SOP documents, assign and manage document periodic reviews, assist in driving CCR works, facilitate new hire orientation, Earth Day event planning, Sustainability Subject Matter Expert for our site



**CITY OF SALEM, MASSACHUSETTS**

Robert K. McCarthy

Mayor

Office of the Mayor

April 13, 2023

Honorable Salem City Council  
Salem City Hall  
Salem, Massachusetts 01970

Ladies and Gentlemen of the City Council:

I am pleased to appoint Sandra O'Donnell of 25 Woodside Street to the Salem Recycling Committee. This letter is being provided to you for informational purposes only, as City Council confirmation is not required for this committee.

Ms. O'Donnell is a retired educator, as a former teacher she is skilled at planning, organizing, and assessing events. A 1978 graduate from Northeastern University, she possesses a BS in Education and in 2003 a Masters in Middle School Education from Salem State University. She has also volunteered with Salem Sound Coastwatch and The American Red Cross.

Please join me in welcoming Ms. O'Donnell to SalemRecycles. We are fortunate that she is willing to serve our community in this important role and lend her expertise and insights to the group and its work.

Sincerely,

Robert K. McCarthy  
Mayor  
City of Salem

CC: Janelle Rolke, City of Salem Waste Reduction Coordinator

April 4, 2023

Dear Mayor McCarthy,

Please consider my application for a seat on the recycling committee. I am eager to support Salem's initiatives in any way I can. Thanks!

Sincerely,  
Sandy O'Donnell  
sodonn722@gmail.com



**CITY OF SALEM, MASSACHUSETTS**

Kimberley Driscoll  
Mayor

**Application for Appointment to City Board or Commission**

For a complete list of City boards visit [www.salem.com/boards](http://www.salem.com/boards). Please send this form, along with a current resume, to [mayor@salem.com](mailto:mayor@salem.com) or mail to: Mayor's Office, City Hall, 93 Washington Street, Salem MA 01970.

Name: Sandra O'Donnell  
Address: 25 Woodside St Salem MA  
Email: sodonn722@gmail.com  
Daytime Phone: 978 979 6794 Evening Phone: Same

Current occupation: Retired educator

Board or commission in which you are interested: Recycling

Why are you interested in serving on this board or commission?

I am interested in supporting Salem's recycling initiatives because it's a crucial way to reduce and prevent pollution as well as slowing the filling up of landfills. Recycling can reduce our demand on natural resources.

In addition to the experience listed in your attached resume, what specific skills or expertise do you believe you can bring to this board or commission?

I am organized and reliable + passionate about recycling. As a former teacher, I am skilled at planning, organizing and assessing events. I can evaluate and summarize data collected to determine the effectiveness of our efforts.

If you are currently serving on any other City boards, please indicate which:  $\emptyset$

Signature:

Sandra O'Donnell

Date:

4/4/23



# **Sandra Pinkus O'Donnell**

25 Woodside Street

Salem MA 01970

[sodonn722@gmail.com](mailto:sodonn722@gmail.com)

978-979-6794

## **Experience**

April 2021 - June 2021

**BILH vaccination clinic**, Beverly, MA

- Administrative assistant: intake and check out of vaccination patients (part time)

September 2004- November 2020

**Holten Richmond Middle School, Danvers, MA** -*Science teacher*

- 8th grade classroom science teacher
- Interdisciplinary team leader 2009-2016
- Science department teacher leader 2016-2020
- Retired: November 2020

September 2001-June 2004

**Garfield Middle School, Revere, MA** - *Science teacher*

- 8th grade classroom science teacher

August 1990-January 2001

**Mariner Health Care, Boston, MA** - *Director of Case Management*

- Managed admission decisions for rehabilitation facility
- Monitored and managed patient care plans during patient stay
- Facilitated discharge plans for patients

## **Volunteer Work**

- **Salem Sound Coastwatch** 2021
- **Red Cross**, donor ambassador 2022/23

## **Education**

2003 **Salem State University** -*M. Ed-Middle School Education*

1978 **Northeastern University**-*BS- Education*



**CITY OF SALEM, MASSACHUSETTS**

**Robert K. McCarthy**  
Mayor

April 13, 2023

Honorable Salem City Council  
Salem City Hall  
Salem, Massachusetts 01970

Ladies and Gentlemen of the City Council:

I appoint, subject to Council confirmation, Lisa Gray Duffy of 112 Columbus Avenue Salem, MA to the Salem Cultural Council for three-year term to expire on April 13, 2026.

Ms. Duffy is a retired School nurse from the Saltonstall School in Salem. Ms. Duffy is a 1990 Graduate of Salem State University, she possesses a BS in Nursing.

She possesses a strong interest in and involvement in the arts. She brings a familiarity with music, painting, and a collaborative work ethic. Ms. Duffy sings with The Salem State Community Chorus and the Grace Episcopal choir. She is an amateur painter and brings a passion for building the community exposure to and participation in the arts.

Ms. Duffy looks forward to working with the commission in future endeavors to benefit the City having a long history of community organizing and dedication to the arts and growing our cultural heritage.

I hope you will act quickly to approve Ms. Duffy's appointment to the Salem Cultural Council. Our city is fortunate indeed that she is willing to serve.

Very truly yours,

A handwritten signature in blue ink, appearing to read "Robert K. McCarthy".

Robert K. McCarthy  
Mayor



**CITY OF SALEM, MASSACHUSETTS**

Kimberley Driscoll

Mayor

**Application for Appointment to City Board or Commission**

For a complete list of City boards visit [www.salem.com/boards](http://www.salem.com/boards). Please send this form, **along with a current resume**, to [mayor@salem.com](mailto:mayor@salem.com) or mail to: Mayor's Office, City Hall, 93 Washington Street, Salem MA 01970.

Name: *Linn Gray Duffy*

Address: *112 Columbus Ave Salem*

Email: *lbgduffy55@gmail.com*

Daytime Phone: *978-766-2259* Evening Phone: *None*

Current occupation: *Retired*

Board or commission in which you are interested: *Salem Cultural Council*

Why are you interested in serving on this board or commission?

*I am a fervent supporter of the arts, especially the arts as a reflection of and change agent of a community. I, now, in my retirement have time to actively participate in bringing arts + culture to this city that I love.*

In addition to the experience listed in your attached resume, what specific skills or expertise do you believe you can bring to this board or commission?

*I bring a love and familiarity of music, painting and a collaborative work ethic. I sing with the Salem State Community Chorus and the Grace Episcopal Choir. I am an amateur painter and bring a passion for building the community exposure and participation.*

If you are currently serving on any other City boards, please indicate which:

*n/a*

Signature:

*L. Duffy*

Date: *3.16.23*

# Lisa Gray Duffy

112 Columbus Ave  
Salem MA 01970  
978-766-2259  
lbgduffy55@gmail.com

## EXPERIENCE

### **Adecco, Salem Public Schools — COVID tester**

September 2021-June 2022

Performed nasal swabbing covid test for elementary school students

### **Salem Public Schools, Saltonstall School — School nurse**

AY 2005/2006 to June 2021

Providing first aid, medical assessment, medication administration, for 350-400 students in a K-8th grade school setting. Provided education around hygiene, nutrition, safety and puberty. Co-wrote the Puberty Health curriculum that is currently in use, making it more inclusive and relevant to all students. Wrote health and wellness newsletter for the school community. Advised the GSA.

## EDUCATION

### **Salem State College (now University), Salem MA — BS Nursing**

Graduated 1990

Passed Board of Registration Nursing exams June 1990

### **Kenyon College, Gambier OH — BA Psychology**

Graduated May 1977

## SKILLS

Medical knowledge especially pertaining to the school pages child

Caring, compassion, patience, very strong interpersonal skills

Strong organization skills

Solid computer skills.

Board Certified School Nurse

Amateur painter in acrylics and watercolor

## AWARDS

Recognized for supporting all students, especially those in the LBGTQ+ community

## LANGUAGES

English



## CITY OF SALEM, MASSACHUSETTS

Robert K. McCarthy  
Acting Mayor

April 13, 2023

To the City Council  
City Hall  
Salem, Massachusetts

Ladies and Gentlemen of the Council:

I re-appoint Dominic Panico of 10 Buffum Street Apt 3. Salem, MA to serve as a Constable in the City of Salem. Mr. Panico has a three-year bond to expire April 13, 2026.

Very truly yours,

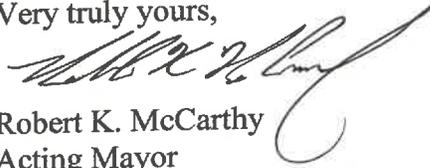
  
Robert K. McCarthy  
Acting Mayor

**UTICA MUTUAL INSURANCE COMPANY**  
**NEW HARTFORD, NEW YORK**

**PUBLIC OFFICIAL BOND**

Bond No. SU5184537

KNOW ALL MEN BY THESE PRESENTS, That I, Dominic Panico  
of 10 Buffum St Apt 3, Salem, MA 01970-2383 as principal and THE UTICA MUTUAL  
INSURANCE COMPANY, NEW HARTFORD, NEW YORK, a corporation formed and existing under the  
laws of New York, with its Home Office located at 180 Genesee Street, New Hartford, New York, and  
authorized to do business in the State of MA, as Surety, are held and firmly bound unto  
City of Salem in the penalty of  
Five Thousand Dollars and Zero Cents Dollars (\$ 5,000), to the payment whereof, well and  
truly to be made and done, the said Principal binds himself, his heirs, executors and administrators, and the said  
Surety binds itself, its successors and assigns, jointly and severally, firmly by these presents.

WHEREAS, the said Principal was duly elected or appointed to the office or position of  
**Constable**

for the term beginning 9/12/2019 12:00:00 AM, and is continuous until cancelled.

NOW, THEREFORE, The Condition of The Foregoing Obligation is Such, that if said Principal shall  
well and truly perform all the duties of his said office or position, and account for all funds coming into his  
hands by virtue of his aid office or position as required by law, then this obligation shall be null and void,  
otherwise to be and remain in full force and virtue.

THIS BOND, is executed and delivered to be effective only upon the following express conditions,  
which shall be conditions precedent to the right of recovery hereunder: **AGENT COPY**

If the Surety shall so elect this Bond shall be cancelled by giving Thirty (30) Days notice in writing to  
the City of Salem and this Bond shall be deemed canceled at the expiration  
of said Thirty (30) Days, the Surety remaining liable for all or any act or acts covered by this Bond, which may  
have been committed by the Principal up to the effective date of such cancellation, subject to the term,  
conditions and provisions of this Bond.

The liability under this Bond shall commence from September 12, 2019, and the Surety hereunder shall in  
no event be held liable in respect to any act or acts of the said Principal committed prior to the said date or for  
any shortage existing prior to the said date, or for funds or property used or applied towards such shortage.

\_\_\_\_\_  
Dominic Panico Principal (L.S.)

UTICA MUTUAL INSURANCE COMPANY

BY: \_\_\_\_\_  
Noreen Dandurant ,Attorney-in-Fact



# CITY OF SALEM

In City Council,

**Ordered:**

April 13, 2023

That the sum of Four Thousand Hundred Dollars (\$4,000) is hereby appropriated in the "Retirement Stabilization Fund-Vacation/Sick Leave Buyback" account (83113-5146) to be expended for the sick leave buybacks to be paid out for active employees pursuant to collective bargaining agreements with various unions in accordance with the recommendation of His Honor the Mayor.



**CITY OF SALEM, MASSACHUSETTS**

**Robert K. McCarthy**  
Mayor

April 13, 2023

To the City Council  
City Hall  
Salem, Massachusetts

Ladies and Gentlemen of the Council:

Enclosed herewith is a request for an appropriation of Four Thousand dollars (\$4,000.00) from the "Retirement Stabilization Fund-Vacation/Sick Leave Buyback" account (83 113-5146) to be expended for the sick leave buybacks to be paid out of active employees pursuant to collective bargaining agreements with various unions.

I recommend passage of the accompanying Order.

Very truly yours,

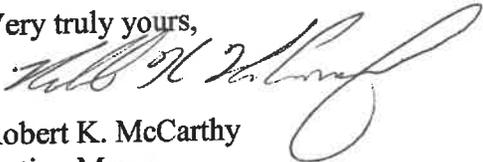
  
Robert K. McCarthy  
Acting Mayor





**ROBERT K. McCARTHY**  
**ACTING MAYOR**

**LISA B. CAMMARATA**  
**DIRECTOR OF HUMAN RESOURCES**

**CITY OF SALEM MASSACHUSETTS**  
**HUMAN RESOURCES**  
**98 WASHINGTON STREET, 3<sup>RD</sup> FLOOR**  
**SALEM, MASSACHUSETTS 01970**  
**TEL. 978-619-5630**

April 11, 2023

Robert K. McCarthy, Acting Mayor  
City of Salem  
93 Washington Street  
Salem, Massachusetts 01970

**RE: Retirement Stabilization**

Dear Acting Mayor:

I am respectfully requesting the amount of \$4,000.00 be appropriated in the Retirement Stabilization Fund for sick leave buybacks submitted in accordance with collective bargaining agreements with our various unions.

Sick leave buy-back to be paid out under this appropriation request are for active employees, not retirees, who wish to take advantage of contractual language allowing members to buyback certain amounts of unused sick leave, on an annual basis. A lump sum request for this purpose will allow us to process those requests.

A breakdown by bargaining unit is as follows:

Salem Firefighter's Union:	\$3,000.00
Patrolman's Union:	\$1,000.00

Thank you for your attention and cooperation with this request, and if you have any questions, please do not hesitate to contact me.

Very truly yours,

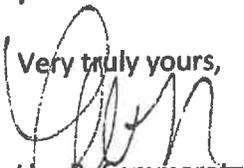
  
Lisa B. Cammarata

cc: File



# CITY OF SALEM

In City Council,

Ordered:

April 13, 2023

Per MGL Chapter 44 Section 64 which allows for a municipality to pay for prior fiscal year invoices using current fiscal year appropriations by two-thirds vote of the City Council we request the sum of Five Hundred Sixty-One Dollars and Sixty Cents (\$561.60) of outstanding Fiscal Year 2020 invoices is hereby allowed to be paid from the Fiscal Year 2023 Police Department budget as listed below in accordance with the recommendation of His Honor the Mayor.

Department	Vendor	Amount
Police Department (12102-5384 Animal Care)	Bulger Veterinary Hospital	\$ 561.60
<b>Total</b>		<b>\$ 561.60</b>



**CITY OF SALEM, MASSACHUSETTS**

Robert K. McCarthy  
Mayor

April 13, 2023

To the City Council  
City Hall  
Salem, Massachusetts

Ladies and Gentlemen of the Council:

Enclosed herewith is a request to approve the payment of Five Hundred and Sixty-One Dollars and Sixty cents (\$561.60) from the Police Department (12102-5384) Animal Care to Bulger Veterinary Hospital, for services for an outstanding Fiscal Year 2020 invoice to be paid from Fiscal Year 2023 budget.

This order is necessary to cover the cost for an invoice for an FY 2020 payment for Bulger Veterinary Hospital per MGL Chapter 44 Section 64, which allows for a municipality to pay for prior fiscal year invoices using current fiscal year appropriation by two-thirds vote of the City Council.

I recommend passage of the accompanying Order.

Very truly yours,

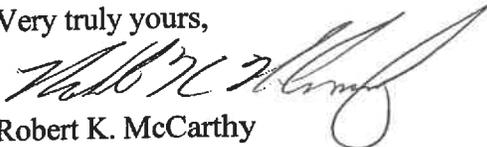
  
Robert K. McCarthy  
Mayor



CHIEF OF POLICE  
LUCAS J. MILLER

**City of Salem, Massachusetts**  
**Police Department Headquarters**  
95 Margin Street  
Salem, Massachusetts 01970  
(978) 744-2204

March 20, 2023

Acting Mayor Robert McCarthy  
Salem City Hall  
93 Washington Street  
Salem, MA 01970

Re: Bulger Veterinary Hospital Invoice #1836692 (Fiscal Year 2020)

Dear Acting Mayor McCarthy -

I would like to request the attached invoice in the amount of \$561.60 dated December 22, 2019 be paid out our Fiscal Year 2023 Animal Care Budget Line (12102-5384).

We have confirmed with ACO Donald Famico that we are responsible for payment on the attached Invoice. A Purchase Order was never issued and we never received the invoice until March 2023. Our office has spoken with Bulger Veterinary Hospital directly to confirm the invoice is accurate and outstanding.

Due to the fact that this expense occurred from Fiscal Year 2020, we are requesting the amount be paid from our FY2023 Animal Care Budget Line.

Sincerely,

A handwritten signature in black ink, appearing to read "Robert D. Mulligan".

Robert D. Mulligan for  
Chief of Police, Lucas J. Miller

RMD: jc  
Enclosure



141 Winthrop Ave  
Lawrence, MA, 01843  
Ph: 978-682-9905  
Fax: 978-975-0133  
Email: bvhclientcare@ethosvet.com

**Customer Name:**  
Salem Ma Police Department

**Patient Name:**  
Big Boi

**Patient Number:**  
455432

**Customer Address:**  
95 Margin St.  
Salem, MA, 01970

**Invoice Date:**  
12-22-2019

**Invoice Number:**  
1836692

Description	Price	Quantity	Total
Nursing Care - Medical Boarding (Per Shift)	\$62.40	1	\$62.40
Hospitalization (Per Shift)	\$31.20	1	\$31.20
Charges Verified	\$0.00	1	\$0.00
Hospitalization (Per Shift)	\$31.20	1	\$31.20
Nursing Care - Medical Boarding (Per Shift)	\$62.40	1	\$62.40
Charges Verified	\$0.00	1	\$0.00
Nursing Care - Medical Boarding (Per Shift)	\$62.40	1	\$62.40
Hospitalization (Per Shift)	\$31.20	1	\$31.20
Hospitalization (Per Shift)	\$31.20	1	\$31.20
Nursing Care - Medical Boarding (Per Shift)	\$62.40	1	\$62.40
Hospitalization (Per Shift)	\$31.20	1	\$31.20
Nursing Care - Medical Boarding (Per Shift)	\$62.40	1	\$62.40
Nursing Care - Medical Boarding (Per Shift)	\$62.40	1	\$62.40
Hospitalization (Per Shift)	\$31.20	1	\$31.20
<b>Subtotal:</b>			<b>\$561.60</b>



**Bulger Veterinary Hospital**  
141 Winthrop Ave  
Lawrence, MA, 01843  
Ph: 978-682-9905  
Fax: 978-975-0133

Including tax: **\$561.60**

Total: **\$561.60**

Payment method:	Amount paid:	Balance:
<b>Invoice 2466826 :</b>	<b>\$211.60</b>	<b>350.00</b>
<b>-211.60</b>		

**PAYMENT TERMS: COD**

Payment in full is expected upon completion of treatment.

Administration fees and collection fees will be applied to overdue accounts.

Bulger Veterinary Hospital cannot accept any medications for return once they have been taken from the hospital.

**NEXT APPOINTMENT:**

Review your pet's medical records and process online payments on Bulger Veterinary Hospital's website. Click the link and login to access the client portal.

[https://ethosma.usel.ezyvet.com/external/portal#googtrans\(en](https://ethosma.usel.ezyvet.com/external/portal#googtrans(en)



# CITY OF SALEM

In City Council,

**Ordered:**

April 13, 2023

That the City Council hereby approves the submittal of the City of Salem's Application for Federal Assistance to the United States Department of Housing and Urban Development (HUD) for Community Development Block Grant (CDBG) funds for the period of July 1, 2023 through June 30, 2024 in the amount determined by HUD's formula entitlement allocation (\$1,059,113.00).

---



**CITY OF SALEM, MASSACHUSETTS**

Robert K. McCarthy  
Mayor

March 31, 2023

Salem City Council  
City of Salem  
93 Washington Street  
Salem, MA 01970

Ladies and Gentlemen of the Council:

Enclosed is an Order authorizing submission of the City's *Application for Federal Assistance* to the U. S. Department of Housing & Urban Development (HUD) for Community Development Block Grant (CDBG) funds for the period of July 1, 2023 through June 30, 2024. For HUD program year 2023 (Fiscal Year 2024), Salem's estimated CDBG entitlement is \$1,059,113.00. In 2020, the City completed its 5-Year Consolidated Plan, outlining Salem's housing, economic and community development needs and funding priorities. In order to receive Federal funds, the City is required to develop Annual Action Plans which put into action the goals and strategies established in the Consolidated Plan.

For the FY24 Action Plan, the process began with a virtual public hearing which held on January 19, 2023, along with the issuance of a request for funding proposals from agencies to provide housing, economic development and public service programs, and from municipal departments for infrastructure and public facilities improvements. The Draft FY24 Action Plan describes the proposed activities to be undertaken during the upcoming fiscal year. A link to the plan was emailed to you on March 27, 2023. As part of the formal public review process, a 30-day public comment period commenced on March 30th and a remote public hearing is scheduled for April 20<sup>th</sup>.

I recommend approval of the application so that it can be transmitted to HUD in a timely manner. Tom Daniel and Amanda Chiancola are available to answer any questions you may have.

Very truly yours,

A handwritten signature in black ink, appearing to read "Robert K. McCarthy".

Robert K. McCarthy  
Acting Mayor  
City of Salem





# CITY OF SALEM

In City Council, April 13, 2023

**ORDERED:** That the City Council and School Committee accept nominations for the vacancy of a School Committee Member due to the resignation of James Fleming as of April 7, 2023. Those interested in being nominated must be a Registered Voter in Salem and send a letter of interest or resume which must be filed in the City Clerk's Office by **Monday, May 1, 2023, by 12:00 P.M.**

And that a Joint Convention of the City Council and School Committee be held in the City Council Chambers in-person on **Thursday, May 4, 2023, at 6:00 P.M.** for the purpose of electing a School Committee member to fill the vacancy.



## CITY OF SALEM

In City Council, April 13, 2023

**ORDERED:** That the Traffic and Parking Department provide to the City Council a list of all traffic lights in Salem, under the jurisdiction of the City of Salem, that do not currently prohibit "Right on Red". Additionally, that the Traffic and Parking Department provide the cost the creation of appropriate signage to prohibit "Right on Red". These items are requested by the May 25 meeting.



# CITY OF SALEM

In City Council April 13, 2023

ORDERED: That the monthly financial reports dated December 2022, January 2023, and February 2023 be received and filed



## CITY OF SALEM

In City Council, April 13, 2023

**ORDERED:** that the Committee on Ordinances Licenses and Legal Affairs co posted with the Committee of the Whole meet to review the City of Salem Code of Ordinances Chapter 2, Article 4, Division 14 (The Affordable Housing Trust Fund Board of Trustees), Sec 2-1001 (Composition) and Sec 2-1002 (Appointments of trustees; term; vacancies) to discuss the composition and number of trustees appointed to determine if this configuration allows the Affordable Housing Trust Fund Board to achieve its goals and purposes.

PART III - CODE OF ORDINANCES  
Chapter 2 - ADMINISTRATION  
ARTICLE IV. - BOARDS, COMMISSIONS, COMMITTEES AND AUTHORITIES  
DIVISION 14. AFFORDABLE HOUSING TRUST FUND BOARD OF TRUSTEES

---

***DIVISION 14. AFFORDABLE HOUSING TRUST FUND BOARD OF TRUSTEES<sup>1</sup>***

**Sec. 2-1000. Established.**

The affordable housing trust fund board of trustees is established.

(Ord. of 10-26-2006, § 1)

**Sec. 2-1001. Composition.**

The affordable housing trust fund board of trustees shall be composed of ~~12~~ 8 trustees, including the mayor ~~and two members of the city council.~~

(Ord. of 10-26-2006, § 1)

**Sec. 2-1002. Appointment of trustees; term; vacancies.**

The mayor shall serve as a trustee and appoint annually in January, subject to confirmation by the city council, ~~four~~ three trustees who shall serve for a term of one year and appoint biennially, subject to confirmation by the city council, four trustees who shall serve for a term of two years. ~~The city council shall annually elect two members of the city council to serve for a term of one year. The city council president or the city council president's designee shall serve for a term of one year.~~ No trustee, excluding the mayor, shall serve for a term exceeding two years. If a vacancy shall occur among the trustees, it shall be filled in the same manner as the original appointment for the unexpired term.

(Ord. of 10-26-2006, § 1; Ord. of 5-13-2021, § I)

**Sec. 2-1003. Compensation.**

The trustees shall serve without compensation.

(Ord. of 10-26-2006, § 1)

**Sec. 2-1004. Removal.**

Trustees may be removed by a majority vote of the city council, subject to approval of the mayor.

(Ord. of 10-26-2006, § 1)

---

<sup>1</sup>State law reference(s)—M.G.L.A. c. 44, § 55C.

---

## **Sec. 2-1005. Powers and duties.**

The trustees shall administer an affordable housing trust fund to provide for the creation and preservation of affordable housing within the City of Salem for the benefit of low to moderate income households.

The specific powers and duties of the trustees, all of which shall be carried on in furtherance of the purposes set forth in this division, are as follows:

- (1) To accept and receive property, whether real or personal, by gift, grant, devise, or transfer from any person, firm, corporation or other public or private entity, including without limitation grants of funds or other property tendered to the trust in connection with provisions of any zoning ordinance or by-law or any other ordinance or by-law;
- (2) To purchase and retain real or personal property, including without restriction investments that yield a high rate of income or no income;
- (3) To sell, lease, exchange, transfer or convey any personal, mixed, or real property at public auction or by private contract for such consideration and on such terms as to credit or otherwise, and to make such contracts and enter into such undertaking relative to trust property as the board deems advisable notwithstanding the length of any such lease or contract;
- (4) To execute, acknowledge and deliver deeds, assignments, transfers, pledges, leases, covenants, contracts, promissory notes, releases and other instruments sealed or unsealed, necessary, proper or incident to any transaction in which the board engages for the accomplishment of the purposes of the trust;
- (5) To employ advisors and agents, such as accountants, appraisers and lawyers as the board deems necessary;
- (6) To pay reasonable compensation and expenses to all advisors and agents and to apportion such compensation between income and principal as the board deems advisable;
- (7) To apportion receipts and charges between incomes and principal as the board deems advisable, to amortize premiums and establish sinking funds for such purpose, and to create reserves for depreciation depletion or otherwise;
- (8) To participate in any reorganization, recapitalization, merger or similar transactions; and to give proxies or powers of attorney with or without power of substitution to vote any securities or certificates of interest; and to consent to any contract, lease, mortgage, purchase or sale of property, by or between any corporation and any other corporation or person;
- (9) To deposit any security with any protective reorganization committee, and to delegate to such committee such powers and authority with relation thereto as the board may deem proper and to pay, out of trust property, such portion of expenses and compensation of such committee as the board may deem necessary and appropriate;
- (10) To carry property for accounting purposes other than acquisition date values;
- (11) To borrow money on such terms and conditions and from such sources as the board deems advisable, to mortgage and pledge trust assets as collateral;
- (12) To make distributions or divisions of principal in kind;
- (13) To comprise, attribute, defend, enforce, release, settle or otherwise adjust claims in favor or against the trust, including claims for taxes, and to accept any property, either in total or partial satisfaction of any indebtedness or other obligation, and subject to the provisions of this act, to continue to hold the same for such period of time as the board may deem appropriate;

- 
- (14) To manage or improve real property; and to abandon any property which the board determined not to be worth retaining;
  - (15) To hold all or part of the trust property uninvested for such purposes and for such time as the board may deem appropriate; and
  - (16) To extend the time for payment of any obligation to the trust.
  - (17) To study, evaluate, and recommend policies, programs, practices, ordinances, and similar measures to increase and maintain the availability of affordable and workforce housing in the City of Salem.

The powers and duties enumerated above are intended to encompass all powers and duties of the trustees. Any action, power or duty not enumerated above shall require prior approval of the city council.

(Ord. of 10-26-2006, § 1; Ord. of 12-6-2018(3) , § 1)

### **Sec. 2-1006. Records; annual report.**

The trustees shall keep a record of its doings and at the close of every fiscal year make a report thereof to the city council. The report shall include a description and source of funds received and expended and the type of affordable housing programs or properties assisted with the funding. The trustees shall also provide the city council with a copy of the trust's annual audit.

(Ord. of 10-26-2006, § 1)

### **Secs. 2-1007—2-1009. Reserved.**



# CITY OF SALEM

In City Council, April 13, 2023

**ORDERED:** That the corner of Cabot and Gardner Streets be named Pelletier Square after US Army Private Rene "Pete" Pelletier and who was killed in action on May 5, 1945



American Veterans Post 53

American Legion Post 23

Polish Legion of American  
Veterans Post 55

Second Corps of Cadets



Military Order of the Purple Heart

Disabled American Veterans  
Chapter 84

Veterans of Foreign Wars  
Post 1524

Marine Corps League  
Essex County Detachment 127

## *Salem Veterans Council*

Joseph Cole, Commander

30 March 2023

FROM: SALEM VETERANS COUNCIL  
TO: SALEM CITY COUNCIL

SUBJ: ENDORSEMENT FOR VETERAN SQUARE NAMING

1. On behalf of the family, the Salem Veterans Council and the Director of Veteran Services, Kim F. Emerling, fully endorse the naming of the below city square in honor of a Salem veteran who lost his life in the service of his country during WWII.

**Pelletier Square:** to be located at the corner of Cabot and Gardner Streets in Ward 5. US Army Private Rene "Pete" Pelletier resided at 22 Cabot Street prior to his enlistment. After induction on 21 September 1942, Pelletier trained as an Infantryman before attending the United States Parachute School at Ft. Benning, GA. He went on to be assigned to the relatively new 504<sup>th</sup> Parachute Regiment that was later attached to the 82<sup>nd</sup> Airborne Division. On 3 February 1945, during the Battle of the Bulge around the town of Bastogne, Private Pelletier was killed in action, two months before Victory in Europe (VE) Day on 5 May 1945. Private Pelletier is interred at Henri-Chapelle American Cemetery in Hombourg, Belgium.

2. This veteran meets the eligibility criteria of having been a resident of the City of Salem upon entry into the Armed Forces and having made the ultimate sacrifice in defense of our freedoms and our American way of life. It is requested that this endorsement be given favorable consideration by the City Council.

3. We expect to dedicate this square on Memorial Day 2023 with his many family members, fellow veterans, and the Salem community.

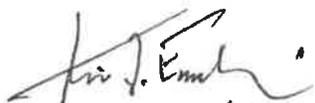
  
Director of Veteran Services  
City of Salem

  
J. M. Cole  
Commander  
Salem Veterans Council

# City of Salem

---

*In the year Two Thousand and Twenty-Three*

## **An Ordinance Relative to Traffic**

*Be it ordained by the City Council of the City of Salem, as follows:*

**Section 1.** Section 50A of Article V be amended by repealing the following:

Hazel Street – Handicap Parking Zones – in front of #30, for a distance off twenty (20) feet, Handicap Parking, Tow Zone.

**Section 2.** Section 50B of Article V be amended by repealing the following:

Hazel Street – Handicap Zones, Limited Time – in front of #20A, Handicapped Parking, Tow Zone (12/9/96)

Hazel Street – Handicap Zones, Limited Time – in front of #38, for a distance of twenty (20) feet. (4/11/02)

**Section 3.** Section 75 of Article V-A be amended by repealing the following:

Hazel Street – Parking Prohibitions Towing Zone (Resident Sticker) – Zone E – Color Orange – even side between Laurel Street and Holly Street.

And inserting the following:

Hazel Street - Parking Prohibitions Towing Zone (Resident Sticker) – Zone E – Color Orange – westerly side, beginning at the intersection with Ocean Avenue and continuing to the intersection with Holly Street.

**Section 4.** This ordinance shall take effect as provided by City Charter.

## **Ilene Simons**

---

**From:** David Kucharsky  
**Sent:** Wednesday, April 5, 2023 11:47 AM  
**To:** Ilene Simons  
**Cc:** Jeff Cohen; David M. Tucker; Maureen Fisher; Chris Sicuranza  
**Subject:** Hazel Street - Ordinance Amendments  
**Attachments:** Proposed Ordinance Changes - Hazel Street.docx

Ilene,

Attached please find an ordinance amendment which seeks to introduce resident parking on Hazel Street from Ocean Avenue to Holly Street. Resident parking currently exists on Hazel from Laurel to Holly. This seeks to extend it from Ocean to Holly. The amendment also includes a cleanup of the ordinance which removes some accessible parking spaces which are no longer designated on the street. I worked with Councilor Cohen and Lt. Tucker to develop these recommendations which included sending out a notice to the direct abutters asking for their feedback on the introduction of resident parking. All of the residents who responded were in favor of the change.

David Kucharsky  
Director of Traffic & Parking  
98 Washington Street, 2<sup>nd</sup> Floor  
Salem, MA 01970  
978-619-5697







**City of Salem, Massachusetts**  
**Office of the City Council**  
**City Hall**



**REQUEST FOR TRAFFIC ORDINANCE RECOMMENDATION**

MEMO TO: Lt. David Tucker Police Traffic Division  
 FROM: Councilor Cohen DATE: April 11, 2023

In accordance with the Council Rule 32A, I hereby request your recommendation for the following Traffic Ordinance:

**NAME OF STREET** Hazel Street

**TYPE OF STREET CHANGE** Handicapped Zones, Limited Time

**DESCRIPTION OF AREA WHERE CHANGE IS REQUESTED** In front of 38 Hazel Street.

**COUNCILLOR'S COMMENTS/EXPLANATION** There are two ordinances for the same accessible space in front of 38 Hazel Street. This recommendation would delete the older language.

**POLICE TRAFFIC DIVISION RECOMMENDATION**

The Police Traffic Division hereby submits the following recommendation for the above request:

XX APPROVAL  
 \_\_\_\_\_ DENIAL  
 \_\_\_\_\_ TRIAL PERIOD

CHAPTER: 42 SECTION: 50B TITLE: Handicapped Zones, Limited Time

DESCRIPTION: Repeal: Hazel Street – in front of #38, for a distance of twenty (20) feet. (4/11/02)

COMMENTS (IF ANY): \_\_\_\_\_

\_\_\_\_\_

**POLICE TRAFFIC DIVISION**

**RETURN THIS FORM TO THE CITY CLERK'S OFFICE**

*City of Salem Clerk's Office, 93 Washington St. Salem, Massachusetts 01970*

*(978) 745-9595 ext 41202 www.salem.com*



**City of Salem, Massachusetts**  
Office of the City Council  
City Hall



**REQUEST FOR TRAFFIC ORDINANCE RECOMMENDATION**

MEMO TO: Lt. David Tucker Police Traffic Division  
FROM: Councilor Cohen DATE: April 11, 2023

In accordance with the Council Rule 32A, I hereby request your recommendation for the following Traffic Ordinance:

NAME OF STREET Hazel Street

TYPE OF STREET CHANGE Parking Prohibitions Towing Zone (Resident Sticker)

DESCRIPTION OF AREA WHERE CHANGE IS REQUESTED Hazel Street, between Ocean Avenue and Holly Street.

COUNCILLOR'S COMMENTS/EXPLANATION Residents of Hazel Street have requested an extension of the resident sticker zone to deal with increased pressure from non-residents parking.

**POLICE TRAFFIC DIVISION RECOMMENDATION**

The Police Traffic Division hereby submits the following recommendation for the above request:

APPROVAL  
 DENIAL  
 TRIAL PERIOD

CHAPTER: 42 SECTION: 75 TITLE: Parking Prohibitions Towing Zone (Resident Sticker)

DESCRIPTION: Repeal: ZONE E COLOR ORANGE, even side between Laurel Street and Holly Street. (11/17/11)

Replace with: Hazel Street - Parking Prohibitions Towing Zone (Resident Sticker) – Zone E – Color Orange – westerly side, beginning at the intersection with Ocean Avenue and continuing to the intersection with Holly Street.

COMMENTS (IF ANY): .

\_\_\_\_\_

**POLICE TRAFFIC DIVISION**

**RETURN THIS FORM TO THE CITY CLERK'S OFFICE**

City of Salem

**In the year two thousand and twenty-three**

**An Ordinance** to amend an Ordinance relative to Traffic

*Be it Ordained by the City Council of the City of Salem, as follows:*

**Section 1.** Chapter 42, Section 50B – “Handicap Zone Limited Time” is hereby amended by adding the following:

Washington Square East – in front of #70 Washington Square East, running in a southerly direction for twenty (20) feet. “Handicap Parking, Limited Time, Tow Zone”

**Section 2.** This Ordinance shall take effect as provided by City Charter.





City of Salem, Massachusetts  
Office of the City Council  
City Hall



**REQUEST FOR TRAFFIC ORDINANCE RECOMMENDATION**

MEMO TO: Lt. David Tucker Police Traffic Division  
FROM: Councilor Watson-Felt DATE: April 11, 2023

In accordance with the Council Rule 32A, I hereby request your recommendation for the following Traffic Ordinance:

NAME OF STREET Washington Square East

TYPE OF STREET CHANGE Handicapped Zones, Limited Time

DESCRIPTION OF AREA WHERE CHANGE IS REQUESTED In front of 70 Washington Square East.

COUNCILLOR'S COMMENTS/EXPLANATION A resident of 70 Washington Square East, who has a disability, has requested an accessible parking space. The space would improve their access to their home.

**POLICE TRAFFIC DIVISION RECOMMENDATION**

The Police Traffic Division hereby submits the following recommendation for the above request:

APPROVAL  
 DENIAL  
 TRIAL PERIOD

CHAPTER: 42 SECTION: 50B TITLE: Handicapped Zones, Limited Time

DESCRIPTION: Washington Square East – in front of #70 Washington Square East, running in a southerly direction for twenty (20) feet.

COMMENTS (IF ANY): \_\_\_\_\_

Lt. David Tucker  
POLICE TRAFFIC DIVISION

**RETURN THIS FORM TO THE CITY CLERK'S OFFICE**

City of Salem Clerk's Office, 93 Washington St. Salem Massachusetts 01970

(978) 745-9595 ext 41202 www.salem.com

**CITY OF SALEM  
CIUDAD DE SALEM**



In City Council, April 13, 2023  
En Consejo, 13 de abril de 2023

**ORDERED:** That the meetings of the qualified voters of the City of Salem be held in the several voting precincts in the City at the polling places designated hereinafter on **Tuesday, May 16, 2023**, for the purpose of casting votes in the City's Special Final Election for the election of candidates for the following office:

**ORDENADO:** Que las reuniones de los votantes calificados de la Ciudad de Salem se lleven a cabo en los diversos recintos electorales de la Ciudad en los lugares de votación designados a continuación el **martes 16 de mayo de 2023**, con el propósito de emitir votos en la Elección Final Especial de la Ciudad para la elección de candidatos para el siguiente cargo:

**Mayor: to fill vacancy due to the resignation of Kimberley Driscoll**  
**Alcalde: para llenar la vacante debido a la renuncia de Kimberley Driscoll**

**AND BE IT FURTHER ORDERED:** That the following places be and hereby are designated as polling places for said meetings:

**Y SE ORDENE ADEMÁS:** Que los siguientes lugares sean y por la presente sean designados como lugares de votación para dichas reuniones:

**WARD ONE / DISTRITO UNO**

Precinct 1	Bentley Academy Gymnasium, 25 Memorial Drive
Recinto 1	Gimnasio, Escuela Bentley Academy, 25 Memorial Drive
Precinct 2	Community Room, 135 Lafayette Street
Recinto 2	Sala Comunitaria, 135 Lafayette Street

**WARD TWO / DISTRITO DOS**

Precinct 1 & 2	Community Life Center, 401 Bridge Street
Recinto 1 & 2	Centro De Vida Comunitaria, 401 Bridge Street

**WARD THREE / DISTRITO TRES**

Precinct 1 & 2	Salem High School Auditorium, 77 Willson Street
Recinto 1 & 2	Auditorio, Salem High School, 77 Willson Street

**WARD FOUR / DISTRITO CUATRO**

Precinct 1 & 2	Witchcraft Heights School Gymnasium, 1 Frederick Street
Recinto 1 & 2	Gimnasio, Escuela Witchcraft Heights, 1 Frederick Street

**WARD FIVE / DISTRITO CINCO**

Precinct 1 & 2	Saltonstall School Auditorium, 211 Lafayette Street
Recinto 1 & 2	Auditorio, Escuela Saltonstall, 211 Lafayette Street

**WARD SIX / DISTRITO SEIS**

Precinct 1 & 2	Bates School Gymnasium, 53 Liberty Hill Avenue
Recinto 1 & 2	Gimnasio, Escuela Bates School, 53 Liberty Hill Avenue

**WARD SEVEN / DISTRITO SIETE**

Precinct 1 & 2  
Recinto 1 & 2

Salem State Enterprise Center, 121 Loring Avenue  
Salem State Enterprise Center, 121 Loring Avenue

AND BE IT FURTHER ORDERED: That the polls at said meetings be opened at 7:00 a.m. and closed at 8:00 p.m. and that the City Clerk be instructed to post this notice as required by law.

Y SE ORDENE ADEMÁS: Que las urnas en dichas reuniones se abran a las 7:00 a.m. y se cierren a las 8:00 p.m. y que se instruya al Secretaria de la Ciudad que publique este aviso como lo exige la ley.

Given under our hands this 27th day of April 2023.  
Dado bajo nuestras manos este 27 de abril de 2023.

---

---

---

---

---

---

---

---

---

---

City Council, City of Salem  
Ayuntamiento, Ciudad de Salem



# CITY OF SALEM

In City Council, April 13, 2023

Ordered:

Notwithstanding Chapter 2 of the Massachusetts Acts of 2023 allowing public bodies to continue holding public meetings remotely until March 31, 2025, the City Council and its Standing Committees shall meet in person. In person shall be the primary method of public access to such meetings. A secondary method of public access may be provided, if technologically feasible, though Salem Access Television and/or remotely through technological means such as Zoom.

A quorum of members must be present in person unless a meeting is posted noting that the meeting will be held as a hybrid meeting, meaning both in person and remotely and enabling a quorum to include members present in Council Chambers and remotely. A hybrid meeting may only be held if members of the public can observe and listen to the meeting, or if it is a public hearing, they are able to provide public comment remotely.

All meeting notices shall indicate clearly whether or not the primary method of public access is in person, in person with a secondary public access via remote participation, or hybrid where the in-person and remote access must both be available. If applicable, the meeting notice shall indicate how members of the public may access the meeting remotely including the relevant links, URLs, access codes, PINs, meeting ID numbers, or telephone numbers.

This Order supersedes the Remote Participation Policy adopted by the City Council on March 24, 2022.

**ELIZABETH M. RENNARD**  
CITY SOLICITOR  
TEL: 978.619.5633  
[BRENNARD@SALEM.COM](mailto:BRENNARD@SALEM.COM)



**CITY OF SALEM**

ROBERT MCCARTHY, ACTING MAYOR

LEGAL DEPARTMENT  
93 WASHINGTON STREET  
SALEM, MASSACHUSETTS 01970  
FAX: 978.744.1279

April 13, 2023

Salem City Council  
City Hall  
Salem, MA 01970

Ladies and Gentlemen of the Council:

At a recent meeting of the City Council's Committee on Public Health, Safety and the Environment (PHSE), co-posted with the Committee of the Whole, I was asked to prepare an Order relative to establishing in-person meetings as the primary method of public access to City Council and Committee meetings. Enclosed herewith is a proposed Order.

I have based the proposed Order on the current practice of holding Council meetings in person and recent communications with the Attorney General's Division of Open Government following technical difficulties with a zoom link at a PHSE meeting.

If you have any questions relative to the proposed Order, please contact me at your earliest convenience. Thank you.

Sincerely,

Elizabeth Rennard

Enclosure

## Ilene Simons

---

**From:** Beth Rennard  
**Sent:** Tuesday, April 11, 2023 9:29 AM  
**To:** Megan Stott; Patricia Morsillo; Ilene Simons  
**Subject:** meetings  
**Attachments:** order - council meetings in person.docx

After speaking with Ilene, I revised the second paragraph by deleting the phrase "within 48 hours" because she would be able to revise an agenda posted as in person with remote as a secondary/convenience and make it a true hybrid meeting even if it is less than 48 hrs. This would be in the event a quorum is unable to appear in person.

Elizabeth Rennard  
City Solicitor  
City of Salem Legal Department  
93 Washington Street  
Salem, MA 01970  
978-619-5633  
978-744-1279 (fax)  
[brennard@salem.com](mailto:brennard@salem.com)



# CITY OF SALEM

In City Council, **April 13, 2023**

Ordered:

In accordance with Massachusetts General Law, Chapter 268A, Section 20(b) the City Council hereby declares that James Rogers has met the requirements for exemption as set forth in this Section and may be retained as an art and science instructor by the Park, Recreation and Community Services Department, not to exceed 500 hours in this calendar year.

**ELIZABETH M. RENNARD**  
CITY SOLICITOR  
TEL: 978.619.5633  
[BRENNARD@SALEM.COM](mailto:BRENNARD@SALEM.COM)



**CITY OF SALEM**

ROBERT MCCARTHY, ACTING MAYOR

LEGAL DEPARTMENT  
93 WASHINGTON STREET  
SALEM, MASSACHUSETTS 01970  
FAX: 978.744.1279

April 13, 2023

Salem City Council  
City Hall  
Salem, MA 01970

Ladies and Gentlemen of the Council:

Enclosed herewith is a proposed Order approving a Massachusetts Conflict of Interest Law exemption for James Rogers, as provided in General Law c. 268A, § 20(b), to work as an art and science instructor for the Park, Recreation and Community Services Department.

The Conflict of Interest Law, specifically General Law c. 268A, § 20(b), requires that because James Rogers will provide personal services to the Park, Recreation and Community Services Department, he must receive City Council approval of a § 20(b) exemption. A copy of the required disclosure form and instructions are attached for your review.

If you have any questions relative to the proposed Order, please contact me at your earliest convenience. Thank you.

Sincerely,

Elizabeth Rennard

Enclosure



## CHAPTER 268A. CONDUCT OF PUBLIC OFFICIALS AND EMPLOYEES

### Chapter 268A: Section 20. Municipal employees; financial interest in contracts; holding one or more elected positions

Section 20. (a) A municipal employee who has a financial interest, directly or indirectly, in a contract made by a municipal agency of the same city or town, in which the city or town is an interested party of which financial interest he has knowledge or has reason to know, shall be punished by a fine of not more than three thousand dollars or by imprisonment for not more than two years, or both.

This section shall not apply if such financial interest consists of the ownership of less than one per cent of the stock of a corporation.

This section shall not apply (a) to a municipal employee who in good faith and within thirty days after he learns of an actual or prospective violation of this section makes full disclosure of his financial interest to the contracting agency and terminates or disposes of the interest, or (b) to a municipal employee who is not employed by the contracting agency or an agency which regulates the activities of the contracting agency and who does not participate in or have official responsibility for any of the activities of the contracting agency, if the contract is made after public notice or where applicable, through competitive bidding, and if the municipal employee files with the clerk of the city or town a statement making full disclosure of his interest and the interest of his immediate family, and if in the case of a contract for personal services (1) the services will be provided outside the normal working hours of the municipal employee, (2) the services are not required as part of the municipal employee's regular duties, the employee is compensated for not more than five hundred hours during a calendar year, (3) the head of the contracting agency makes and files with the clerk of the city or town a written certification that no employee of that agency is available to perform those services as part of their regular duties, and (4) the city council, board of selectmen or board of aldermen approve the exemption of his interest from this section.

**DISCLOSURE BY MUNICIPAL EMPLOYEE  
OF FINANCIAL INTEREST IN A MUNICIPAL CONTRACT  
AS REQUIRED BY G. L. c. 268A, § 20(b)**

MUNICIPAL EMPLOYEE INFORMATION	
Name of municipal employee:	James Rogers
Title/ Position	Teacher Bentley School
Fill in this box if it applies to you.	If you are a municipal employee because a municipal agency has contracted with your company or organization, please provide the name and address of the company or organization.
Agency/ Department	Salem School Dept.
Agency Address	25 Memorial Drive, Salem 01970
Office phone:	<del>978</del> 978-740-1260
Office e-mail:	jrogers@salemk12.org
	Check one: <input type="checkbox"/> Elected    or <input checked="" type="checkbox"/> Non-elected
Starting date as a municipal employee.	2022
<b>BOX # 1</b>  Select either STATEMENT #1 or STATEMENT #2.  Write an X beside your financial interest.	<p><b>ELECTED MUNICIPAL EMPLOYEE</b></p> <p>I am an elected municipal employee.</p> <p><input type="checkbox"/> <b>STATEMENT #1:</b> I had one of the following financial interests in a contract made by a municipal agency before I was elected to my municipal employee position. I will continue to have this financial interest in a municipal contract. <b>OR</b></p> <p><input type="checkbox"/> <b>STATEMENT #2:</b> I will have a new financial interest in a contract made by a municipal agency.</p> <p><b>My financial interest in a municipal contract is:</b></p> <p><input type="checkbox"/> I have a non-elected, compensated municipal employee position.</p> <p><input type="checkbox"/> A municipal agency has a contract with me.</p> <p><input type="checkbox"/> I have a financial benefit or obligation because of a contract that a municipal agency has with another person or an entity, such as a company or organization.</p> <p><input type="checkbox"/> I work for a company or organization that has a contract with a municipal agency, and I am a "key employee" because the contract identifies me by name or it is otherwise clear that the city or town has contracted for my services in particular.</p>
<b>BOX # 2</b>  Select either STATEMENT #1 or STATEMENT #2.	<p><b>NON-ELECTED, COMPENSATED MUNICIPAL EMPLOYEE</b></p> <p>I am a non-elected municipal employee.</p> <p><input type="checkbox"/> <b>STATEMENT # 1:</b> I had one of the following financial interests in a contract made by a municipal agency before I took a position as a non-elected municipal employee. I will continue to have this financial interest in a municipal contract.</p>

<p><b>Write an X beside your financial interest.</b></p>	<p><b>My financial interest in a municipal contract is:</b></p> <p><input type="checkbox"/> A municipal agency has a contract with me, but not an employment contract.</p> <p><input type="checkbox"/> I have a financial benefit or obligation because of a contract that a municipal agency has with another person or an entity, such as a company or organization.</p> <p><b>-- OR --</b></p> <p><input type="checkbox"/> <b>STATEMENT # 2:</b> I will have a <b>new</b> financial interest in a contract made by a <b>municipal</b> agency.</p> <p><b>My financial interest in a municipal contract is:</b></p> <p><input checked="" type="checkbox"/> I have a non-elected, compensated municipal employee position.</p> <p><input type="checkbox"/> A municipal agency has a contract with me.</p> <p><input type="checkbox"/> I have a financial benefit or obligation because of a contract that a municipal agency has with another person or an entity, such as a company or organization.</p> <p><input type="checkbox"/> I work for a company or organization that has a contract with a municipal agency, and I am a "key employee" because the contract identifies me by name or it is otherwise clear that the city or town has contracted for my services in particular.</p>
<p><b>FINANCIAL INTEREST IN A MUNICIPAL CONTRACT</b></p>	
<p>Name and address of municipal agency that made the contract</p>	<p>City of Salem Park, Recreation and Community Services 401 Bridge St. Salem, MA 01970</p>
<p><b>Please put in an X to confirm these facts.</b></p>	<p><b>"My Municipal Agency"</b> is the municipal agency that I serve as a <b>municipal employee</b>.</p> <p>The <b>"contracting agency"</b> is the <b>municipal agency that made the contract</b>.</p> <p><input checked="" type="checkbox"/> My Municipal Agency is not the contracting agency.</p> <p><input checked="" type="checkbox"/> My Municipal Agency does not regulate the activities of the contracting agency.</p> <p><input checked="" type="checkbox"/> In my work for my Municipal Agency, I do not participate in or have official responsibility for any of the activities of the contracting agency.</p> <p><input checked="" type="checkbox"/> The contract was made after public notice or through competitive bidding.</p>
<p><b>FILL IN THIS BOX OR THE BOX BELOW</b></p>	<p><b>ANSWER THE QUESTION IN THIS BOX IF THE CONTRACT IS BETWEEN THE CITY OR TOWN AND YOU.</b></p> <p>- Please explain what the contract is for.</p> <p>To teach art and science classes to youth through Salem Park and Recreation during school vacations and one week during the summer.</p>
<p><b>FILL IN THIS BOX OR THE BOX ABOVE</b></p>	<p><b>ANSWER THE QUESTIONS IN THIS BOX IF THE CONTRACT IS BETWEEN THE CITY OR TOWN AND ANOTHER PERSON OR ENTITY.</b></p> <p>- Please identify the person or entity that has the contract with the municipal agency.</p> <p>- What is your relationship to the person or entity?</p> <p>- What is the contract for?</p>

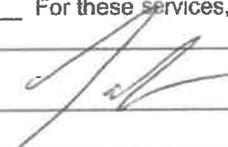
What is your financial interest in the municipal contract?	- Please explain the financial interest and include the dollar amount if you know it.
Date when you acquired a financial interest	
What is the financial interest of your immediate family?	- Please explain the financial interest and include the dollar amount if you know it.
Date when your immediate family acquired a financial interest	
Write an X to confirm each statement.	<p><b>FOR A CONTRACT FOR PERSONAL SERVICES –</b></p> <p>Answer the questions in this box ONLY if you will have a contract for personal services with a municipal agency (i.e., you will do work directly for the contracting agency).</p> <p>I will have a contract with a municipal agency to provide personal services.</p> <p><input checked="" type="checkbox"/> The services will be provided outside my normal working hours as a municipal employee.</p> <p><input checked="" type="checkbox"/> The services are not required as part of my regular duties as a municipal employee.</p> <p><input checked="" type="checkbox"/> For these services, I will be compensated for not more than 500 hours during a calendar year.</p>
Employee signature:	
Date:	4/7/2023

Attach additional pages if necessary.

NOT A PERSONAL SERVICES CONTRACT -- File disclosure with the city or town clerk.

SEE CERTIFICATION AND APPROVAL REQUIRED FOR PERSONAL SERVICES CONTRACTS, BELOW.

**FOR CONTRACTS FOR PERSONAL SERVICES ONLY:**

If you are disclosing a financial interest in a contract for personal services with a municipal agency, you must file the Certification below signed by the head of the contracting agency, and you must get approval of the exemption from the city council, board of aldermen, board of selectmen or town council.

**CERTIFICATION BY HEAD OF CONTRACTING AGENCY**

<b>INFORMATION ABOUT HEAD OF CONTRACTING AGENCY</b>	
Name:	Patricia O'Brien
Title/ Position	Superintendent – Salem Park, Recreation and Community Services
Municipal Agency:	City of Salem
Agency Address:	401 Bridge St. Salem, MA 01970
Office Phone:	978-744-0924
<b>CERTIFICATION</b>	
	I have received a disclosure under G.L. c. 268A, § 20(b) from a municipal employee who seeks to provide personal services to my municipal agency, identified above. I certify that no employee of my agency is available to perform the services described above as part of his or her regular duties.
Signature:	
Date:	April 7, 2023

**APPROVAL BY CITY COUNCIL, BOARD OF ALDERMEN,  
BOARD OF SELECTMEN OR TOWN COUNCIL**

<b>INFORMATION ABOUT APPROVING BODY</b>	
Name:	
Title/ Position	
Agency Address:	
Office Phone:	
<b>APPROVAL</b>	
	I have received a disclosure under G.L. c. 268A, § 20(b) from a municipal employee who seeks to provide personal services to a municipal agency, identified above. The exemption under § 20(b) is approved.
Signature:	On behalf of the Council or Board, I sign this approval.
Date:	

Attach additional pages if necessary.  
File disclosure, Certification and Approval with the city or town clerk.



# CITY OF SALEM

In City Council, April 13, 2023

## Ordered:

That the City Solicitor work with the Health Agent, Building Commissioner and Executive Director of the Salem Redevelopment Authority, or their designees, and the City Clerk to draft an amendment to the City Ordinance relative to outdoor dining (café permits) to allow for and regulate the use of public ways (sidewalks and parking spaces) for restaurants to build outdoor dining areas and to establish limitations and procedures for such use commencing in 2024. The Solicitor shall submit a draft to the City Council no later than May 8, 2023.

Questions contact – Sibhita Mahabier 781-258-9169

Petition of the Massachusetts Electric Company d/b/a National Grid  
Of NORTH ANDOVER, MASSACHUSETTS  
For Electric conduit Location:

To City Council of Salem, Massachusetts

Respectfully represents the Massachusetts Electric Company d/b/a National Grid of North Andover, Massachusetts, that it desires to construct a line of underground electric conduits, including the necessary sustaining and protecting fixtures, under and across the public way or ways hereinafter named.

Wherefore it prays that after due notice and hearing as provided by law, it be granted permission to excavate the public highways and to run and maintain underground electric conduits, together with such sustaining and protecting fixtures as it may find necessary for the transmission of electricity, said underground conduits to be located substantially in accordance with the plan filed here with marked: Highland Ave - Salem - Massachusetts.

The following are the streets and highways referred to:  
Plan # 30549376 Highland Ave - National Grid to install beginning at a point approximately 585' +/- feet northeast of the centerline of the intersection of Barnes Rd and continuing approximately 5' +/- feet in a southeasterly direction. Installation of 5 ft +/- of 2-5" PVC conduits encased in concrete from Pole # 1569 to the property of 373 Highland Ave.

Location approximately as shown on plan attached

Massachusetts Electric Company d/b/a  
NATIONAL GRID *Bob Coulter*  
BY \_\_\_\_\_  
Engineering Department

Dated: April 4, 2023

**ORDERED:**

Notice having been given and public hearing held, as provided by law, that the Massachusetts Electric Company d/b/a National Grid be and it is hereby granted permission to excavate the public highways and to run and maintain underground electric conduits, together with such sustaining and protecting fixtures as said company may deem necessary, in the public way or ways hereinafter referred to, and to make the necessary house connections along said extensions, as requested in petition with said company dated the 4th day of April, 2023.

Said underground electric conduits shall be located substantially in accordance with the plan filed herewith marked – Highland Ave - Salem - Massachusetts. Plan # 30549376.

The following are the public ways or part of ways along which the underground electric conduits above referred to may be laid:

Highland Ave - National Grid to install beginning at a point approximately 585' +/- feet northeast of the centerline of the intersection of Barnes Rd and continuing approximately 5' +/- feet in a southeasterly direction. Installation of 5 ft +/- of 2-5" PVC conduits encased in concrete from Pole # 1569 to the property of 373 Highland Ave.

I hereby certify that the foregoing order was adopted at a meeting of the .....  
.....  
....., held on the ..... day of ....., 20 .....  
....., 20 .....

Received and entered in the records of location orders of the City/Town of  
Book ..... Page .....

Attest:  
.....

..... hereby certify that on .....20....., at ..... o'clock, ...M  
at ....., a public hearing was held on the petition of  
Massachusetts Electric Company d/b/a National Grid for permission to construct the underground  
electric conduits described in the order herewith recorded, and that I mailed at least seven days  
before said hearing a written notice of the time and place of said hearing to each of the owners of  
real estate (as determined by the last preceding assessment for taxation) along the ways or parts of  
ways upon which the Company is permitted to construct the underground electric conduits under  
said order. And that thereupon said order was duly adopted.

.....  
.....  
.....



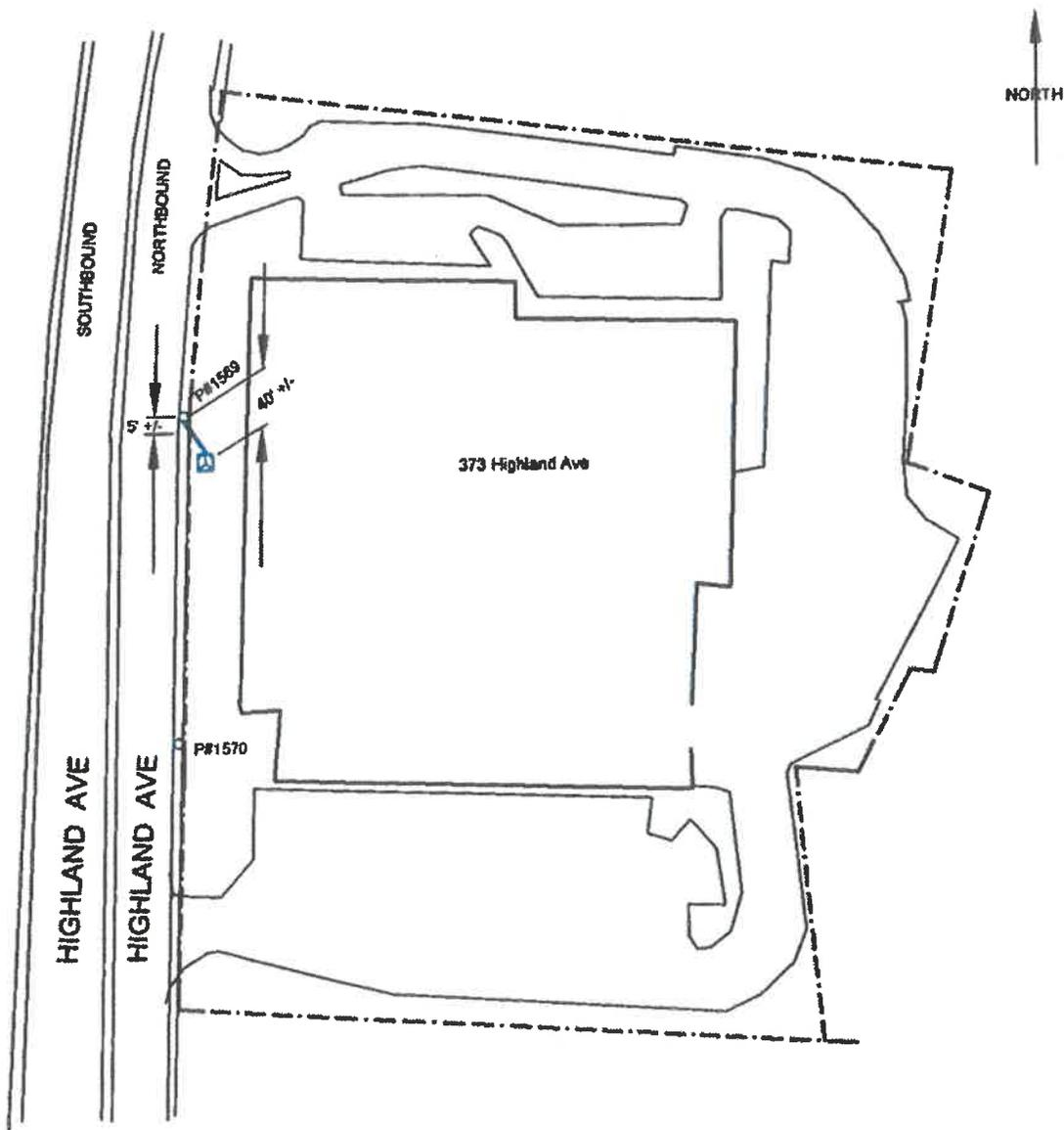

**UNDERGROUND PETITION**

-  JO POLE (EXISTING)
-  PROPOSED PAD TRANSFORMER
-  PROPOSED HANHOLE
-  EDGE OF STREET
-  PROPOSED CONDUIT 2-5"
-  Property Line

**nationalgrid**

Sketch to Accompany Petition for the installation of 5ft +/- of 2-5" PVC conduits encased in concrete from P# 1569 to the property of 373 Highland Ave., Salem, MA 01970

Date: 09-22-2022

WORK REQUEST: 12-22-30549376

To The: City Of Salem

For Proposed: 2-5" Conduit Encased in Concrete Location: Highland Ave.

DISTANCES ARE APPROXIMATE

Drawn By: Sibhita Mahabier-Sheehy

INC/feh



CITY OF SALEM, MASSACHUSETTS  
PARK, RECREATION & COMMUNITY SERVICE  
401 Bridge Street, Salem MA 01970  
Tel. (978) 744-0180/(978) 744-0924  
pobrien@salem.com

Kimberley Driscoll  
MAYOR

Trish O'Brien  
Superintendent

**Road Bike/Race/Walk/Parade Application**

PLEASE SUBMIT PAYMENT OF \$200 WITH THIS PERMIT APPLICATION TO THE CITY OF SALEM  
PARK, RECREATION AND COMMUNITY SERVICES DEPARTMENT NO LATER THAN 45 DAYS  
PRIOR TO THE EVENT.  
Registered Non-Profit Fee \$150  
ANY FOR PROFIT EVENTS WILL REQUIRE AN ADDITIONAL 5% FROM THE  
REGISTRATION FEES POST EVENT.

We, the undersigned, respectfully apply for permission to host a road race/walk in the City of Salem as follows:

Applicant's Name: Doug Bollen  
Organization Name: Boys + Girls Club of Greater Salem  
Name of Race/Walk/Parade: Wild Turkey 5 Mile Run  
Contact #: 978-744-0915 E-Mail Address: dbollen@bgcgs.org  
Address: 29 Highland Ave PO. Box 34  
City/State/Zip: Salem MA 01970  
Organization Tax Status (please include Tax ID Number): 042 104 912

What Charities Will This Race/Walk Be Benefiting? Boys + Girls Club of Greater Salem

Approximately How Much of the Race/Walk/Parade Proceeds Will Be Donated to Each Charity(s) 100% to Boys + Girls Club

**Day of Race/Walk Contact Information:**

Name: Doug Bollen Contact #: 978 710 8866  
Date of Event: 11/23/03 Estimated Number of Participants: 1600  
Time of Event: 8:00 AM Estimated Finish Time of Event: 10:00 AM  
Start Location: Washington St West Finish Location: Essex St - Area Visitor Center  
Distance of Event: 5 miles  
Has This Event Been Held Before?  Yes  No

com v P.D. v CC

3/6/23

**All Races/Walks/Parades Are Required to Recycle and Remove Trash.**

Please Explain Your Plan (Will You Bring to North Shore Recycled Fiber on 53 Jefferson Ave, Open M-F; Bring to Your Home Curbside, or Other?), If You Have Questions about Recycling, Please Contact Julie Rose for More Information 978-619-5679

*Will bring to N.S. Recycled Fiber*

Onsite EMT/Ambulance Service (Required): JB initial

Please Attach a Map of Route With the Following Items:

1. Race/Walk Course
2. Direction of Runners Through the Race/Walk course
3. Starting and Finishing Points
4. Meeting Points For Racers Before and After the Race/Walk
5. Last year's race financials

Certificate of Insurance Attached?  Yes  No

A certificate of insurance for general liability naming the City of Salem as primary additional insured for amount not less than \$1,000,000 combined single limit for injury or death or property damages (including loss of use) in any one occurrence, and \$1,000,000 general aggregate coverage. (The City of Salem reserves the right to increase coverage minimum if event presents extraordinary risk).

**RELEASE & INDEMNITY AGREEMENT APPLICANT'S SIGNATURE** The undersigned Sponsor, by signature below, shall defend, indemnify, and hold the City of Salem, its officers, agents and employees, harmless against all liability, loss, or expenses, including attorney's fees, and against all claims, actions or judgments based upon or arising out of damage or injury (including death) to persons or property caused by any act or omission of an act sustained in any way in connections with the performance of this event or by conditions created thereby, or based upon violation of any statute, ordinance or regulation. This contractual indemnity provision does not abrogate common law or statutory liability and indemnification to the City of Salem, but is in addition to such common law or statutory provisions.

Applicant's signature

*Doug Dellen*  
Name of applicant

Date: *3/6/2023*

*Boys + Girls Club*

A copy of this permit will be sent to the applicant upon approval. Please call Park, Recreation & Community Services if you have any questions. 978-744-0924

*#12081*  
CITY USE ONLY

Payment Received: *\$150.00* Date Permit Issued: \_\_\_\_\_ Date Permit Mailed to Applicant: \_\_\_\_\_

Approved By:

Director (Or Designee) of Salem Park, Recreation & Community Services

*3-23-23*  
Salem Police Department

Effective date of form: 2/8/12

Revised date of form: 1/1/18

*3/6/23*

## **20th Annual Wild Turkey 5 Mile Run** course details - street listings

It starts at Washington Square West at the Roger Conant statue and heads on Hawthorne Blvd takes left on Derby st at the Congress-Derby lights. runs all the way down Fort ave to Winter Island Road to Winter Island, runs around the inside of Winter Island and out and takes right on Columbus Square, takes right on to Columbus ave, then takes right to Bay View ave goes around Juniper point and takes right on Beach ave then a left on Columbus ave and then right on Beach toward Willows, takes right at Arcade and runs thru gate at Hobbs popcorn and runs along water inside park and come out near the Clam Shack onto Restaurant Row to Memorial drive, goes all the way to Essex Street across lights at Washington St-Hawthorne Blvd and finishes in front of Visitor's Center on Essex Street.

### **Meeting Point**

The race starts at the Roger Conant Statue on Washington Square West. The home base is the Peabody Essex Museum on the Essex Street Mall. Runners will pick up their race numbers morning of the race and head over to the starting line on Washington Square West. Many runners will have picked up their race numbers the previous day at New England Running Company in Beverly and will show up at starting line of race. Awards will be given out at the Peabody Essex Museum after the race.



2023

**City of Salem**  
**Wild Turkey 5 Mile Run**



1 inch equals 300 feet





MC/ps



# CITY OF SALEM, MASSACHUSETTS

PARK, RECREATION & COMMUNITY SERVICE

401 Bridge Street, Salem MA 01970

Tel. (978) 744-0180/(978) 744-0924

pobrien@salem.com

Kimberley Driscoll  
MAYOR

Trish O'Brien  
Superintendent

## Road Bike/Race/Walk/Parade Application

PLEASE SUBMIT PAYMENT OF \$200 WITH THIS PERMIT APPLICATION TO THE CITY OF SALEM  
PARK, RECREATION AND COMMUNITY SERVICES DEPARTMENT NO LATER THAN 45 DAYS

PRIOR TO THE EVENT.

Registered Non-Profit Fee \$150

ANY FOR PROFIT EVENTS WILL REQUIRE AN ADDITIONAL 5% FROM THE  
REGISTRATION FEES POST EVENT.

We, the undersigned, respectfully apply for permission to host a road race/walk in the City of Salem as follows:

Applicant's Name: Tom Mistretta

Organization Name: Wicked Running Club

Name of Race/Walk/Parade: Miles Over the Moon

Contact #: 978-239-402 E-Mail Address: thomas.mistretta@gmail.com

Address: PO Box 601

City/State/Zip: Salem MA 01970

Organization Tax Status (please include Tax ID Number): 27-1340155

What Charities Will This Race/Walk Be Benefiting?  
Wicked Running Club and its support of College Scholarships and High School Athletics

Approximately How Much of the Race/Walk/Parade Proceeds Will Be Donated to Each Charity(s)  
50% Scholarships, 25% Salem HS <sup>partial</sup> 25% other public HS

### Day of Race/Walk Contact Information:

Name: Tom Mistretta Contact #: 978-239-402

Date of Event: 7/21/2023 <sup>FRIDAY</sup> Estimated Number of Participants: 400

Time of Event: 8 PM Estimated Finish Time of Event: 9:15 PM

Start Location: Bentley School Finish Location: Bentley School

Distance of Event: 4 miles

Has This Event Been Held Before?  Yes  No

Can. v P.A. v C.C.

2/12/22

**All Races/Walks/Parades Are Required to Recycle and Remove Trash.**

Please Explain Your Plan (Will You Bring to North Shore Recycled Fiber on 53 Jefferson Ave, Open M-F; Bring to Your Home Curbside, or Other?) If You Have Questions about Recycling, Please Contact Julie Rose for More Information 978-619-5679

Home / Curbside

Onsite EMT/Ambulance Service (Required): tm initial

Please Attach a Map of Route With the Following Items:

1. Race/Walk Course
2. Direction of Runners Through the Race/Walk course
3. Starting and Finishing Points
4. Meeting Points For Racers Before and After the Race/Walk
5. Last year's race financials

Certificate of Insurance Attached?  Yes  No

A certificate of insurance for general liability naming the City of Salem as primary additional insured for amount not less than \$1,000,000 combined single limit for injury or death or property damages (including loss of use) in any one occurrence, and \$1,000,000 general aggregate coverage. (The City of Salem reserves the right to increase coverage minimum if event presents extraordinary risk).

**RELEASE & INDEMNITY AGREEMENT APPLICANT'S SIGNATURE** The undersigned Sponsor, by signature below, shall defend, indemnify, and hold the City of Salem, its officers, agents and employees, harmless against all liability, loss, or expenses, including attorney's fees, and against all claims, actions or judgments based upon or arising out of damage or injury (including death) to persons or property caused by any act or omission of an act sustained in any way in connections with the performance of this event or by conditions created thereby, or based upon violation of any statute, ordinance or regulation. This contractual indemnity provision does not abrogate common law or statutory liability and indemnification to the City of Salem, but is in addition to such common law or statutory provisions.

Applicant's signature

Thomas M. Mistretta

Date: 3-12-2023

Name of applicant

A copy of this permit will be sent to the applicant upon approval. Please call Park, Recreation & Community Services if you have any questions. 978-744-0924

CITY USE ONLY

Payment Received: #2227 \$150.00 Date Permit Issued: \_\_\_\_\_ Date Permit Mailed to Applicant: \_\_\_\_\_

Approved By:

Director (Or Designee) of Salem Park, Recreation & Community Services

Capt. Mark Brown 3-23-22  
Salem Police Department

Effective date of form: 2/8/12

Revised date of form: 1/1/18



# Create a New Route

Instructions Select location:  Massachusetts or

**Toolbar**

- Draw map
- Add water
- Undo
- To start
- Out & back
- Clear all

**Distance:**

4.03 miles  
6.49 km

**Actions**

- Save
- Print

Map data ©2018 Google Terms of Use Report a map error

## Markers:

Miles

## Route Information

Start at Bentley School at Szetela, running East  
Szetela to Memorial

Memorial to Restaurant Row at Dead Horse Beach

Restaurant Row, take Right onto Fort Ave

Fort Ave to Right on Memorial Drive

Memorial Drive to Left on Larkin, Left on Szetela

Szetela West to Essex

Essex Right to Washington Square East

Washington Square East to Left into Salem Common

Salem Common clockwise loop to Left on Pleasant

Pleasant to Right on Bridge

Bridge to Right on Osgood

Osgood to Right on East Collins St.

East Collins Street to *left* on Bike Path

Bike Path to Left on Szetela running East

Finish at Bentley School

The data shown on this map are intended for informational purposes only. The user should not rely on the data for any legal or other purposes. The user should consult the appropriate authorities for the most current information on the data.

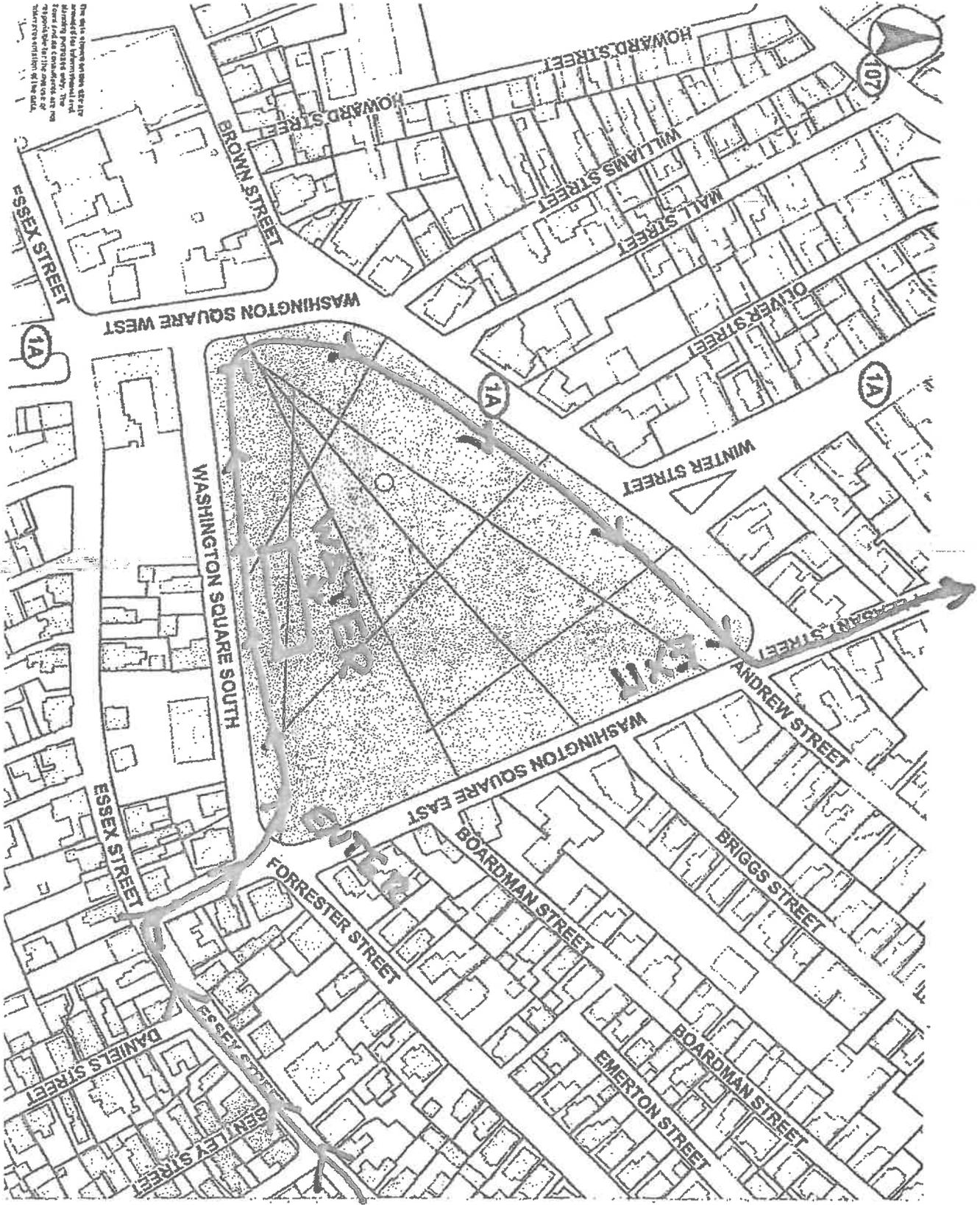

USA Topo

Miles over Moon

START/END @ Bentley School



Salem Willows Park

Freedom At The Willows

Oak Tree 1 Fort Lee

Salem Neck

Fort Lee Revolution Bike Track

Winter Island

Winter Island Waikiki Beach

Winter Island Park

Salem Harbor Master

Halfide Rock

South Essex Sewerage District

Bentley Academy Innovation School

Herb Mackey's Metal Sculpture Yard

The Satanic Temple

Collins Cove Park

Salem Common

Essex Museum Center

Seabody Essex Museum



# CERTIFICATE OF LIABILITY INSURANCE

DATE (MM/DD/YYYY)  
03/13/2023

THIS CERTIFICATE IS ISSUED AS A MATTER OF INFORMATION ONLY AND CONFERS NO RIGHTS UPON THE CERTIFICATE HOLDER. THIS CERTIFICATE DOES NOT AFFIRMATIVELY OR NEGATIVELY AMEND, EXTEND OR ALTER THE COVERAGE AFFORDED BY THE POLICIES BELOW. THIS CERTIFICATE OF INSURANCE DOES NOT CONSTITUTE A CONTRACT BETWEEN THE ISSUING INSURER(S), AUTHORIZED REPRESENTATIVE OR PRODUCER, AND THE CERTIFICATE HOLDER.

**IMPORTANT:** If the certificate holder is an ADDITIONAL INSURED, the policy(ies) must have ADDITIONAL INSURED provisions or be endorsed. If SUBROGATION IS WAIVED, subject to the terms and conditions of the policy, certain policies may require an endorsement. A statement on this certificate does not confer rights to the certificate holder in lieu of such endorsement(s).

<b>PRODUCER</b> Insurance Management Group 12730 Coldwater Rd Ste 103  Fort Wayne IN 46845	<b>CONTACT NAME:</b> Margaret Mayers <b>PHONE (A/C No, Ext):</b> (260) 338-2434 <b>E-MAIL ADDRESS:</b> mmayers@insmgt.com	<b>FAX (A/C No):</b> (765) 664-0761
	<b>INSURER(S) AFFORDING COVERAGE</b>	
<b>INSURED</b>  Road Runners Club of America/2023 and Its Member Clubs  1501 Langston Boulevard, Suite 103 Arlington 22209	<b>INSURER A:</b> National Casualty Company	<b>NAIC #</b> 11991
	<b>INSURER B:</b> Nationwide Life Insurance Company	66869
	<b>INSURER C:</b>	
	<b>INSURER D:</b>	
	<b>INSURER E:</b>	

**COVERAGES**      **CERTIFICATE NUMBER:** 2023 \$1M A.I.      **REVISION NUMBER:**

THIS IS TO CERTIFY THAT THE POLICIES OF INSURANCE LISTED BELOW HAVE BEEN ISSUED TO THE INSURED NAMED ABOVE FOR THE POLICY PERIOD INDICATED. NOTWITHSTANDING ANY REQUIREMENT, TERM OR CONDITION OF ANY CONTRACT OR OTHER DOCUMENT WITH RESPECT TO WHICH THIS CERTIFICATE MAY BE ISSUED OR MAY PERTAIN, THE INSURANCE AFFORDED BY THE POLICIES DESCRIBED HEREIN IS SUBJECT TO ALL THE TERMS, EXCLUSIONS AND CONDITIONS OF SUCH POLICIES. LIMITS SHOWN MAY HAVE BEEN REDUCED BY PAID CLAIMS.

INSR LTR	TYPE OF INSURANCE	ADDL INSD	SUBR WVD	POLICY NUMBER	POLICY EFF (MM/DD/YYYY)	POLICY EXP (MM/DD/YYYY)	LIMITS
A	<input checked="" type="checkbox"/> <b>COMMERCIAL GENERAL LIABILITY</b> <input type="checkbox"/> CLAIMS-MADE <input checked="" type="checkbox"/> OCCUR <input checked="" type="checkbox"/> Legal Liability to <input type="checkbox"/> Participant \$1,000,000  GENL AGGREGATE LIMIT APPLIES PER POLICY <input type="checkbox"/> POLICY <input type="checkbox"/> PROJECT <input type="checkbox"/> LOC <input checked="" type="checkbox"/> OTHER: For Event Basis			KRO000009332900	12/31/2022	12/31/2023	EACH OCCURRENCE \$ 1,000,000 DAMAGE TO RENTED PREMISES (Ea occurrence) \$ 500,000 MED EXP (Any one person) \$ 5,000 PERSONAL & ADV INJURY \$ 1,000,000 GENERAL AGGREGATE \$ 5,000,000 PRODUCTS - COMP/OP AGG \$ 1,000,000 Abuse and Molestation \$ 500,000 COMBINED SINGLE LIMIT (Ea accident) \$ 1,000,000 BODILY INJURY (Per person) \$ BODILY INJURY (Per accident) \$ PROPERTY DAMAGE (Per accident) \$
A	<b>AUTOMOBILE LIABILITY</b> <input type="checkbox"/> ANY AUTO OWNED AUTOS ONLY <input checked="" type="checkbox"/> HIRED AUTOS ONLY <input type="checkbox"/> SCHEDULED AUTOS NON-OWNED AUTOS ONLY			KRO000009332900	12/31/2022	12/31/2023	EACH OCCURRENCE \$ AGGREGATE \$ PER STATUTE    OTH-ER E.L. EACH ACCIDENT \$ E.L. DISEASE - EA EMPLOYEE \$ E.L. DISEASE - POLICY LIMIT \$
	<b>UMBRELLA LIAB</b> <input type="checkbox"/> OCCUR <b>EXCESS LIAB</b> <input type="checkbox"/> CLAIMS-MADE DED    RETENTION \$						EACH OCCURRENCE \$ AGGREGATE \$ PER STATUTE    OTH-ER
	<b>WORKERS COMPENSATION AND EMPLOYERS' LIABILITY</b> ANY PROPRIETOR/PARTNER/EXECUTIVE OFFICER/MEMBER EXCLUDED? (Mandatory in NH) If yes, describe under DESCRIPTION OF OPERATIONS below						E.L. DISEASE - POLICY LIMIT \$ Excess Medical \$10,000 AD & Specific Loss \$2,500
B	Excess Medical & Accident (\$250 Deductible/Claim)			BAX0000031991400	12/31/2022	12/31/2023	

DESCRIPTION OF OPERATIONS / LOCATIONS / VEHICLES (ACORD 101, Additional Remarks Schedule, may be attached if more space is required)  
CERTIFICATE HOLDER IS NAMED AS AN ADDITIONAL INSURED AS RESPECTS TO THEIR INTEREST IN THE OPERATIONS OF THE NAMED INSURED. DATE OF EVENT(S): 07/21/23 Miles Over The Moon - 4 Mile Road Race    INSURED RRCA CLUB/EVENT MEMBER: Wicked Running Club    ATTN: Tom Mistretta, PO Box 601, Salem MA 01970  
Processed by RMV

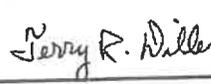
<b>CERTIFICATE HOLDER</b>  07/21/23 City of Salem 93 Washington Street  Salem MA 01970	<b>CANCELLATION</b>  SHOULD ANY OF THE ABOVE DESCRIBED POLICIES BE CANCELLED BEFORE THE EXPIRATION DATE THEREOF, NOTICE WILL BE DELIVERED IN ACCORDANCE WITH THE POLICY PROVISIONS.  AUTHORIZED REPRESENTATIVE 
---	---

City of Salem

**In the year two thousand and twenty-three**

**An Ordinance** to amend an Ordinance relative to Traffic

*Be it Ordained by the City Council of the City of Salem, as follows:*

**Section 1.** Chapter 42, Section 50B – “Handicap Zone Limited Time” is hereby amended by repealing the following:

Repeal – Summer Street – easterly side, beginning fifty-five (55) feet north of Endicott Street and running in a northerly direction for twenty (20) feet. “Handicap Parking, Limited Time, Tow Zone”

**Section 2.** This Ordinance shall take effect as provided by City Charter.

In City Council March 23, 2023  
Adopted for first passage

ATTEST:

ILENE SIMONS  
CITY CLERK

City of Salem

**In the year two thousand and twenty-three**

**An Ordinance** to amend an Ordinance relative to Traffic

*Be it Ordained by the City Council of the City of Salem, as follows:*

**Section 1.** Chapter 42, Section 50B – “Handicap Zone Limited Time” is hereby amended by adding the following:

Summer Street - in front of #73, for a distance of twenty (20) feet,  
“Handicap Parking, Limited Time, Tow Zone”

**Section 2.** This Ordinance shall take effect as provided by City Charter.

In City Council March 23, 2023  
Adopted for first passage.

ATTEST:

ILENE SIMONS  
CITY CLERK

# City of Salem

*In the year Two Thousand and Twenty-Three*

## **An Ordinance Relative to Traffic**

*Be it ordained by the City Council of the City of Salem, as follows:*

**Section 1.** Section 51 of Article V be amended by repealing the following:

Broad Street – Parking Prohibited on Certain Streets - northerly side, beginning at Pickering Street in an easterly direction for thirty (30) feet. (11/13/75 DPW 5-1114)

And inserting the following:

Broad Street – Parking Prohibited on Certain Streets - northerly side, beginning at Pickering Street in an easterly direction for one-hundred and two (102) feet.

**Section 2.** This ordinance shall take effect as provided by City Charter.

In City Council March 23, 2023  
Adopted for first passage

ATTEST:

ILENE SIMONS  
CITY CLERK



# City of Salem

---

*In the year Two Thousand and Twenty-Three*

## **An Ordinance Relative to Traffic**

*Be it ordained by the City Council of the City of Salem, as follows:*

**Section 1.** Section 51B of Article V be amended by repealing the following:

Essex Street – Parking Prohibited at Certain Times on Certain Streets - for a distance of one hundred thirty five feet (135) in a westerly direction beginning ninety-five feet (95) from Summer Street, southerly side. Thirty (30) minute parking, 8:00 A.M. to 6:00 P.M. (11/14/94)

Essex Street – Parking Prohibited at Certain Times on Certain Streets - for a distance of one hundred thirty-five (135) feet in a westerly direction beginning ninety-five (95) from Summer Street, southerly side. Thirty (30) minute parking, 8:00 A. M. to 6:00 P. M. (11/14/94)

**Section 2.** Section 56 of Article V be amended by repealing the following:

Essex Street – Parking Meter Zones Established - northerly side, from North Street in a westerly direction to a point opposite the easterly line of Cambridge Street. Four (4) hour parking. (7/20/87) (7/14/11)

**Section 3.** Section 75 of Article V-A be amended by inserting the following:

Essex Street – Parking Prohibitions Towing Zone (Resident Sticker) – Zone C – Color Green – both sides, beginning at Summer Street and continuing in a westerly direction to Cambridge Street. Two (2) hour nonresident parking allowed, Monday through Sunday, 8:00 A.M. to 6:00 P.M. No visitor passes shall be issued for qualifying addresses on this street.

**Section 4.** This ordinance shall take effect as provided by City Charter.

In City Council March 23, 2023

Adopted for first passage

ATTEST:

ILENE SIMONS  
CITY CLERK

# City of Salem

*In the year Two Thousand and Twenty-Three*

## **An Ordinance Relative to Traffic**

*Be it ordained by the City Council of the City of Salem, as follows:*

**Section 1.** Section 51B of Article V be amended by repealing the following:

Lafayette Street – Parking Prohibited at Certain Times on Certain Streets - easterly side, beginning at the intersection of Ocean Avenue and running in a southerly direction for a distance of one hundred (100) feet. Two (2) hour parking. (11/18/76 DPW 5-1236)

Lafayette Street – Parking Prohibited at Certain Times on Certain Streets - easterly side, extending one hundred (100) feet from Ocean Avenue. Two (2) hour parking. (10/5/76 DPW 5-1210)

Ocean Avenue - Parking Prohibited at Certain Times on Certain Streets - southerly side, beginning at Lafayette Street and running in an easterly direction for one hundred fifty-eight (158) feet, two (2) hour parking. (11/12/15)

Ocean Avenue - Parking Prohibited at Certain Times on Certain Streets - from Lafayette Street to the westerly property line of #39 Ocean Avenue, total distance one hundred and fifty-eight (158) feet. (11/12/15)

**Section 2.** Section 57A of Article V be amended by repealing the following:

Ocean Avenue – Parking Time Limited: Unmetered Zones - northerly side, starting at Lafayette Street and running to the rear property line of 284 Lafayette Street. Two (2) hour parking, Monday through Friday 9:00 A.M. to 6:00 P.M. Resident parking also authorized. (10/13/16)

And inserting the following:

Lafayette Street – Parking Time Limited: Unmetered Zones – easterly side, beginning at Ocean Avenue and running in a southerly direction for seventy-eight (78) feet, Two (2) hour parking, Monday through Friday, 8:00 A.M. to 6:00 P.M.

Ocean Avenue – Parking Time Limited: Unmetered Zones – northerly side, beginning at Lafayette Street and running in a westerly direction, ninety-two (92) feet, one (1) hour nonresident parking allowed, Monday through Friday, 9:00 A.M. to 6:00 P.M.

Ocean Avenue – Parking Time Limited: Unmetered Zones – southerly side, beginning at a point one hundred and three (103) feet west of Lafayette Street and running in an easterly direction to Lafayette Street, one (1) hour nonresident parking allowed, Monday through Friday, 9:00 A.M. to 6:00 P.M.

Ocean Avenue – Parking Time Limited: Unmetered Zones – southerly side, beginning at Lafayette Street and running in an easterly direction for one hundred fifty-five (155) feet, two (2) hour nonresident parking allowed, Monday through Friday, 8:00 A.M. to 6:00 P.M.

**Section 3.** Section 75 of Article V-A be amended by repealing the following:

Ocean Avenue – Parking Prohibitions Towing Zone (Resident Sticker) - Zone E Color Orange - starting from No. 50, both sides, running in a westerly direction to Canal Street. (10/2/90)

**Section 4.** This ordinance shall take effect as provided by City Charter.

In City Council March 23, 2023  
Adopted for first passage

ATTEST:

ILENE SIMONS  
CITY CLERK

City of Salem

**In the year two thousand and twenty-three**

**An Ordinance** to amend an Ordinance relative to Traffic

*Be it Ordained by the City Council of the City of Salem, as follows:*

**Section 1.** Chapter 42, Section 50B – “Handicap Zone Limited Time” is hereby amended by adding the following:

Albion Street - in Front of #33 for a distance of twenty (20) feet,  
“Handicap Parking, Limited Time, Tow Zone”

**Section 2.** This Ordinance shall take effect as provided by City Charter.

In City Council March 23, 2023  
Adopted for first passage

ATTEST:

ILENE SIMONS  
CITY CLERK



# CITY OF SALEM

In City Council, March 23, 2023

Ordered:

Appendix A - Rules and Orders of the City Council, Sec. 26C. Rules for Testimony During "Public Testimony" portion of Regular Meetings is hereby amended by deleting this section in its entirety and replacing it with the following:

**"Sec. 26C. Rules for Testimony During "Public Testimony" portion of Regular Meetings**

**The following rules shall be observed during the "Public Testimony" portion of Regular Meetings of the City Council:**

- 1.. In order to manage Public Testimony in a reasonable amount of time, before opening the Public Testimony portion of the meeting, the President shall, depending on the number of speakers, set a time limit, not to exceed three minutes, which each individual presenting testimony must abide. The Public Testimony portion of the meeting shall not exceed fifteen (15) minutes, extended at the discretion of the President or to a time definite by majority vote of the Council.**
- 2. Anyone wishing to present testimony at a City Council meeting must sign-up online or sign a roster in the Clerk's office up to 30 minutes prior to the start of the meeting. The roster (s) shall be presented to the President of the City Council at the start of the Regular Meeting. Only those individuals whose names appear on the roster may present testimony at the meeting in question.**
- 3. Public testimony shall be conducted in an orderly and peaceable manner. Failure to do so may result in the President terminating the speaker's comment period.**
- 4. The Public Comment period is not a public hearing or a question and answer period."**

In City Council March 23, 2023  
Adopted and remain in committee of the whole

ATTEST:

ILENE SIMONS  
CITY CLERK