

ORDER FOR CONDUIT LOCATION

In the City Council for the City of Salem, Massachusetts.

ORDERED:

That permission be and hereby is granted to Comcast Cable Communications Management LCC., to lay and maintain underground conduits and manholes, with the wires and cables to be placed therein, under the surface of the following public way or ways as requested in petition of said Company dated June 11, 2018

Bridge Street: Proposing to place a 17" x 30" vault and excavate and place (1) 3" PVC conduit 7'± in the sidewalk to service number 160 Bridge Street. As shown on the attached construction plans.

Substantially as shown on plan, filed with said petition.

Also that permission be and hereby is granted said Comcast to lay and maintain underground conduits, manholes, cables and wires in the above or intersecting public ways for the purpose of making connections with such poles and buildings as it may desire for distributing purposes.

The foregoing permission is subject to the following conditions:

1. The conduits and manholes shall be of such materials and construction and all work done in such manner as to be satisfactory to the City Council or to such officers as it may appoint to the supervision of the work.
2. Said Company shall indemnify and save the City harmless against all damages, costs and expense whatsoever to which the City may be subjected in consequence of the acts or neglect of said Company, its agents or servants, or in any manner arising from the rights and privileges granted it by the City.
3. In addition said Company shall, before a public way is disturbed for the laying of its wire or conduits, execute its bond in a penal sum of One Hundred Thousand Dollars (\$100,000) (reference being had to the bond already on file with said City) conditioned for the faithful performance of its duties under this permit.
4. Said Company shall comply with the requirements of existing by-laws and such as may hereafter be adopted governing the construction and maintenance of conduits and wires, so far as the same are not inconsistent with the laws of the Commonwealth.

I hereby certify that the foregoing order was adopted at a meeting of the City Council for the City of Salem, Massachusetts, held on the _____ day of _____ 2018.

(over)

City Clerk

We hereby certify that on _____, 2018, at _____ o'clock _____ M., at Salem, Massachusetts a public hearing was held on the petition of the Comcast for permission to lay and maintain underground conduits, manholes and connections, with the wires and cables to be placed therein, described in the order herewith recorded, that we mailed at least seven days before said hearing a written notice the time and place of said hearing to each of the owners of real estate determined by the last preceding assessment for taxation along the ways parts of ways upon which the Company is permitted to construct the lines said Company under said order. And that thereupon said order was duly adopted.

Salem City Council; Salem, Massachusetts

CERTIFICATE

I hereby certify that the foregoing is a true copy of a location order, and certificate of hearing with the notice adopted by the City Council for the City of Salem, Massachusetts, on the _____ day of _____ 2018, recorded with the records of location orders of said City, Book _____, Page _____. This certified copy is made under the provision of Chapter 166 of General Laws and any additions thereto or amendments thereof.

Attest:

City Clerk



PLAN 454/PLAN 30

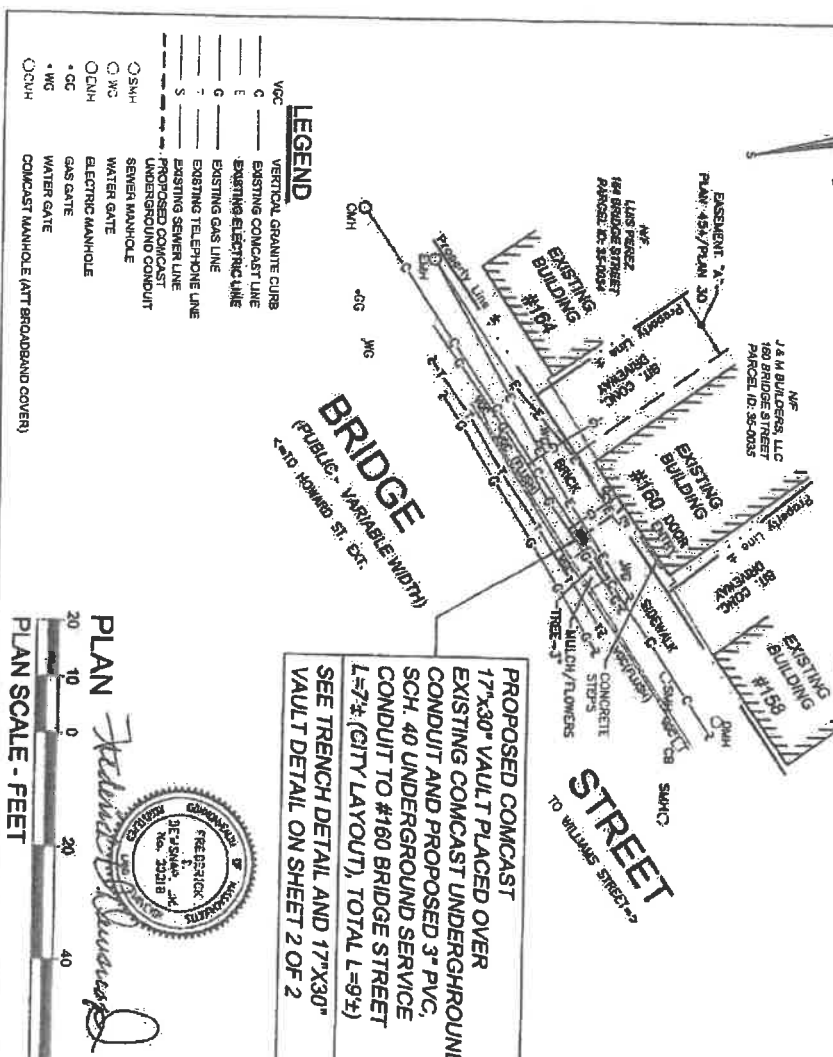

BRIDGE
(PUBLIC - VARIABLE WIDTH)
210' TO HONOLD ST. EXT.

PROPOSED COMCAST
17"x30" VAULT PLACED OVER
EXISTING COMCAST UNDERGROUND
CONDUIT AND PROPOSED 3" PVC,
SCH. 40 UNDERGROUND SERVICE
CONDUIT TO #160 BRIDGE STREET
L=7'± (CITY LAYOUT), TOTAL L=9'±)
SEE TRENCH DETAIL AND 17"x30"
VAULT DETAIL ON SHEET 2 OF 2

- LEGEND**
- VCC VERTICAL GRANITE CURB
 - C EXISTING COMCAST LINE
 - E EXISTING ELECTRIC LINE
 - G EXISTING GAS LINE
 - S EXISTING TELEPHONE LINE
 - PROPOSED COMCAST UNDERGROUND CONDUIT
 - SEWER MANHOLE
 - SNH WATER GATE
 - WC ELECTRIC MANHOLE
 - DUH GAS GATE
 - WC WATER GATE
 - WC COMCAST MANHOLE (ATT BROADBAND COVER)



Dennis W. Pappas

- NOTES:**
1. This plan was prepared from record data on file at the City of Salem, the Essex South Registry of Deeds, and a field location survey performed by the office.
 2. The locations of underground utilities are shown and based on above ground structures and record drawings provided to the Surveyor. Locations of underground utilities structures may vary from locations shown and are not warranted to be accurate and/or correct. Additional buried utilities/structures may be encountered. No excavations were performed during the progress of this survey to locate buried utilities/structures.
 3. Prior to any construction, the Contractor shall notify DIG-SAFE at least 72 hours in advance at 811 (National Call Number) for verification of utilities and for field location.
 4. It is the responsibility of the utility contractor installing the Comcast underground conduit to notify those utility companies not associated with the DIG-SAFE system to verify the locations of their respective utilities.
 5. All work to be performed in the installation of a Comcast 17"x30" vault over the existing Comcast conduit within the sidewalk area and install a 3" PVC Sch. 40 conduit to service #160 Bridge Street.
 6. All work shall conform to the City of Salem Engineering and PUV Standards.
 7. The proposed Comcast conduit and structures shall be adjacent to the Dig-Safe marks.
 8. Upon completion of the trench work for the pipe, the contractor shall backfill, compact the soil and replace all bricks removed using the same pattern. Any other to be done shall comply with the applicable codes.
 9. Street/property lines are not the result of a boundary survey and are considered to be approximate.

CONSTRUCTION NOTES:

1. Following the Dig-Safe "mark out" and field verification of the existing underground utilities, the Proposed 3" PVC Comcast service conduit and the associated 17"x30" Vault shall be adjusted in the field by the utility contractor to avoid being located over any existing utilities.

PROPOSED COMCAST UNDERGROUND	
ESSEX COUNTY	
160 BRIDGE STREET	
SALEM, MA	
Prepared for:	COMCAST 9 Rogers Road, Suite 88 Woburn, MA 01891
Prepared By:	DENISWAP ENGINEERING ASSOC. LLP 778 Union Avenue - Salem, MA 01960 Tel: (781) 253-0255
Date:	JUNE 8, 2018
Checked By:	F.D.D. & P.A.D.
Drawn By:	P.A.D.
Field By:	P.A.D., A.C.D. & A.P.D.
Scale:	1"=20'
Revisions:	
Sheet No. 1 of 2	FILE No.:

QUAZITE SERVICE BOX
 SPECIFICATIONS/DATA
 1. USE STEEL COVER

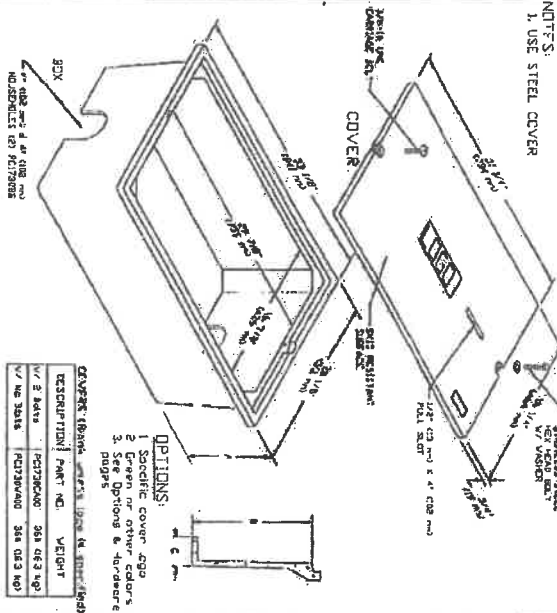

DESCRIPTION	PART NO.	WEIGHT	FINISH
COVER	400 020 2 1/2	12 1/2\"/>	

STRONGWELL
 2001 Pleasant Hill Drive
 Lenoir City, TN 37771
 615/341-2046 • 800/961-9114 • Fax 423/981-2000

HANDHOLE DETAIL

GENERAL CATV TRENCH DETAIL FOR 3" PVC SCH. 40 CONDUIT

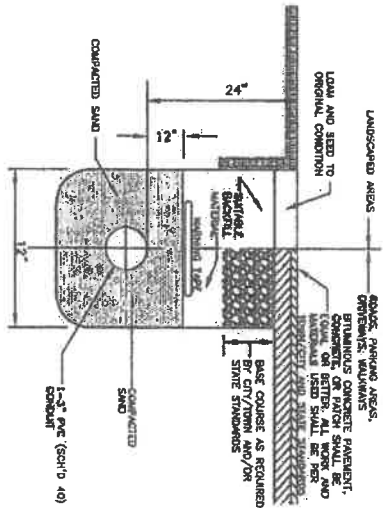

NOTES:

1. The details depicted are for general reference only. The final product used shall be the responsibility of the general contractor and shall be of equal or greater material than that depicted and shall conform to the Engineering DPW Standards for the state, city/town where the project is located.

"DETAILS"

**PROPOSED COMCAST UNDERGROUND
 ESSEX COUNTY
 160 BRIDGE STREET
 SALEM, MA**

Prepared for: COMCAST 9 FORDS ROAD SUITE#B HESBURN, MA 01801	Prepared By: DEWSNAP ENGINEERING ASSOC. LLP 178 Lincoln Avenue - Salem, MA 01956 Tel: 978/781-2330-0585
Date: JUNE 8, 2018	Scale: AS SHOWN
Checked By: F.D.D. & P.A.D.	Revisions:
Drawn By: P.A.D.	
Field By: P.A.D., A.C.D., & A.P.D.	
Sheet No. 2 of 2	FILE No.:



Ilene Simons

From: David Knowlton
Sent: Monday, June 11, 2018 4:20 PM
To: Ilene Simons; John Giardi
Subject: RE: Comcast Petition - 160 Bridge St. - Conduit

Hi ilene, bridge street is city owned, no state highway permit needed
Bridge st has been recently recnstructed, so I would ask for:

1. If construction is required in the sidewalk, entire sidewalk panels will be replaced at the completion of the work.
2. If construction is required in the roadway, the entire roadway surface, curb to curb, from 1 foot on either side of the proposed construcion, be ground out 2-inches and 2-inches on new pavement be installed (curb to curb pavement restoration).

Thanks
david

From: Ilene Simons
Sent: Monday, June 11, 2018 2:56 PM
To: David Knowlton; John Giardi
Subject: Comcast Petition - 160 Bridge St. - Conduit

The attached petition is for your review and comments

Dave, did you find out anything about needing to go through Council if it's a state highway. I never heard of that, but I wanted to check with you. They are still opening a street in Salem that may affect residents.

Ilene Simons
City Clerk
Justice of the Peace
93 Washington St.
Salem, MA 01970
(978) 745-9595 ext. 41202

From: cityclerkmfp@salem.com <cityclerkmfp@salem.com>
Sent: Monday, June 11, 2018 3:54 PM
To: Ilene Simons <ISimons@Salem.com>
Subject: Message from KM_C368

Ilene Simons

From: David Knowlton
Sent: Monday, June 11, 2018 4:22 PM
To: Ilene Simons; John Giardi
Subject: RE: Comcast Petition - 160 Bridge St. - Conduit

Hi ilene, the entire concrete sidewalk panels should be replaced, from the middle of #15 front st, through the driveway opening, to the existing comcast vault in the middle of #17-21 front st, after work is completed.

Thanks
david

From: Ilene Simons
Sent: Monday, June 11, 2018 2:56 PM
To: David Knowlton; John Giardi
Subject: Comcast Petition - 160 Bridge St. - Conduit

The attached petition is for your review and comments

Dave, did you find out anything about needing to go through Council if it's a state highway. I never heard of that, but I wanted to check with you. They are still opening a street in Salem that may affect residents.

Ilene Simons
City Clerk
Justice of the Peace
93 Washington St.
Salem, MA 01970
(978) 745-9595 ext. 41202

From: cityclerkmfp@salem.com <cityclerkmfp@salem.com>
Sent: Monday, June 11, 2018 3:54 PM
To: Ilene Simons <ISimons@Salem.com>
Subject: Message from KM_C368

ORDER FOR CONDUIT LOCATION

In the City Council for the City of Salem, Massachusetts.

ORDERED:

That permission be and hereby is granted to Comcast Cable Communications Management LCC., to lay and maintain underground conduits and manholes, with the wires and cables to be placed therein, under the surface of the following public way or ways as requested in petition of said Company dated April 12, 2018

Front Street: Proposing to excavate and place (1) 3" PVC conduit 35'± from the existing vault located in the sidewalk to service number 15 Front Street. As shown on the attached construction plans.

Substantially as shown on plan, filed with said petition.

Also that permission be and hereby is granted said Comcast to lay and maintain underground conduits, manholes, cables and wires in the above or intersecting public ways for the purpose of making connections with such poles and buildings as it may desire for distributing purposes.

The foregoing permission is subject to the following conditions:

1. The conduits and manholes shall be of such materials and construction and all work done in such manner as to be satisfactory to the City Council or to such officers as it may appoint to the supervision of the work.
2. Said Company shall indemnify and save the City harmless against all damages, costs and expense whatsoever to which the City may be subjected in consequence of the acts or neglect of said Company, its agents or servants, or in any manner arising from the rights and privileges granted it by the City.
3. In addition said Company shall, before a public way is disturbed for the laying of its wire or conduits, execute its bond in a penal sum of One Hundred Thousand Dollars (\$100,000) (reference being had to the bond already on file with said City) conditioned for the faithful performance of its duties under this permit.
4. Said Company shall comply with the requirements of existing by-laws and such as may hereafter be adopted governing the construction and maintenance of conduits and wires, so far as the same are not inconsistent with the laws of the Commonwealth.

I hereby certify that the foregoing order was adopted at a meeting of the City Council for the City of Salem, Massachusetts, held on the _____ day of _____ 2018.

(over)

City Clerk

We hereby certify that on _____, 2018, at _____ o'clock M., at Salem, Massachusetts a public hearing was held on the petition of the Comcast for permission to lay and maintain underground conduits, manholes and connections, with the wires and cables to be placed therein, described in the order herewith recorded, that we mailed at least seven days before said hearing a written notice the time and place of said hearing to each of the owners of real estate determined by the last preceding assessment for taxation along the ways parts of ways upon which the Company is permitted to construct the lines said Company under said order. And that thereupon said order was duly adopted.

Salem City Council; Salem, Massachusetts

CERTIFICATE

I hereby certify that the foregoing is a true copy of a location order, and certificate of hearing with the notice adopted by the City Council for the City of Salem, Massachusetts, on the _____ day of _____ 2018, recorded with the records of location orders of said City, Book _____, Page _____. This certified copy is made under the provision of Chapter 166 of General Laws and any additions thereto or amendments thereof.

Attest:

City Clerk

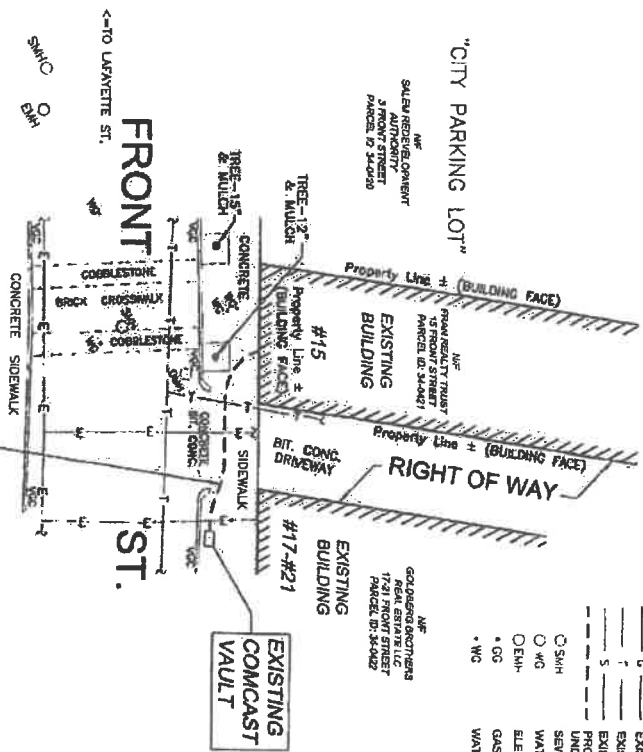
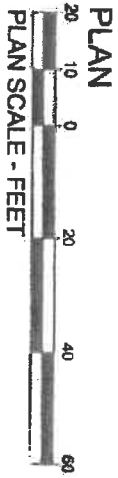

PROPOSED COMCAST
3" PVC, SCH. 40 CONDUIT
SERVICE TO #15 FRONT
STREET - L = 35'±



LEGEND

- VCC VERTICAL GRANITE CURB
- C EXISTING COMCAST LINE
- E EXISTING ELECTRIC LINE
- G EXISTING GAS LINE
- T EXISTING TELEPHONE LINE
- S EXISTING SEWER LINE
- 5 PROPOSED COMCAST UNDERGROUND CONDUIT
- SMH SEWER MANHOLE
- WG WATER GATE
- OW WATER GATE
- OG GAS GATE
- WC WATER GATE

NOTES:

1. This plan was prepared from record data on file at the City of Salem, the Essex South Registry of Deeds, and a field location survey performed by this office.
2. The locations of underground utilities as shown are based on above ground structures and record drawings provided to the Surveyor. Locations of underground utilities/structures may vary from locations hereon and are not warranted to be accurate and/or correct. Additional buried utility structures may be encountered. No excavations were performed during the progress of this survey to locate buried utilities/structures.
3. Prior to any construction, the Contractor shall notify DIG-SAFE at least 72 hours in advance at 811 (National Call Number) for verification of utilities and for field locations.
4. It is the responsibility of the utility contractor installing the Comcast underground conduit to notify those utility companies not associated with the DIG-SAFE system to verify the locations of their respective utilities.
5. There is a gas line in Front Street with services to buildings.
6. All work to be performed is the installation of a Comcast 3" PVC, Sch. 40 conduit to service #15 Front Street.
7. All work shall conform to the City of Salem Engineering and DPW Standards.
8. The proposed Comcast conduits and structures shall be adjusted in the field per the Dig-Safe marks.
9. Upon completion of the trench work for the day, the contractor shall backfill compact the soil and replace all concrete panels per city standards. Areas shall be broom swept clean.
10. Street/Property lines are not the result of a boundary survey and are considered to be approximate.

CONSTRUCTION NOTES:

1. Following the Dig-Safe "mark out" and field verification of the existing underground utilities, the Proposed 3" PVC Comcast service conduit shall be adjusted in the field by the utility contractor to avoid being located over any existing utilities.

PROPOSED COMCAST UNDERGROUND	
ESSEX COUNTY	
15 FRONT STREET	
SALEM, MA	
Prepared for:	COMCAST 9 FORTES ROAD, SUITE 88 WOBURN, MA 01801
Prepared by:	DEVMAP ENGINEERING ASSOC. LLP 178 Linden Avenue - Salem, MA 01970 Tel: (978) 253-0465
Date:	JUNE 8, 2018
Checked by:	F.D.D. & P.A.D.
Drawn by:	P.A.D.
Field By:	P.A.D., A.C.D. & A.P.D.
Scale:	1"=20'
Revisions:	
Sheet No.:	1 of 2

FILE No.:

NOTES:

1. The details depicted are for general reference only. The final product used shall be the responsibility of the general contractor and shall be of equal or greater material than that depicted and shall conform to the Engineering DPW Standards for the state, city/town where the project is located.

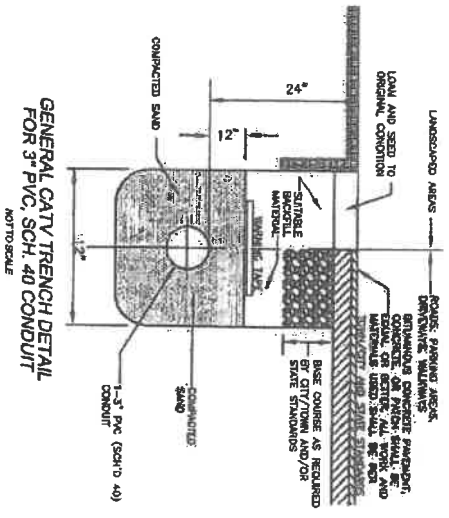

" D E T A I L S "

PROPOSED COMCAST UNDERGROUND

ESSEX COUNTY

15 FRONT STREET

SALEM, MA

Prepared for:	COMCAST 5 FORTRESS ROAD, SUITE 40 WOBURN, MA 01801	Prepared by:	DEWISMAP ENGINEERING ASSOC. LLP 100 BAYVIEW BLVD SALEM, MA 01970 TEL: 978/721-253-6595
Date:	JUNE 8, 2016	Scale:	AS SHOWN
Checked By:	F.D.D. & P.A.D.	Revised:	
Drawn By:	P.A.D.		
Field By:	P.A.D., A.C.D. & A.P.D.		
	Sheet No. 2 of 2	FILE No:	

Frederick D. Cummings





CITY OF SALEM, MASSACHUSETTS

Kimberley Driscoll
Mayor

June 28, 2018

Honorable Salem City Council
Salem City Hall
Salem, Massachusetts 01970

Ladies and Gentlemen of the City Council:

I am pleased to appoint Mark Pattison of 2 Beaver Street to a vacant seat on the Salem Historical Commission for a three-year term to expire June 28, 2021.

A resident of Salem for over thirty years, Mr. Pattison has become a well-known and highly regarded restoration carpenter. He has done work on behalf of the National Park Service at the Salem Maritime National Historic Site on both the Derby House and the West India Goods Store. His work on the central staircase at 55 Perkins Street will be featured on HGTV this month and he is currently restoring a historically significant gate and fence on Chestnut Street. In addition to his professional work, Mr. Pattison is engaged in historic preservation efforts elsewhere, serving as a member of the Danvers Historic District Commission.

I recommend confirmation of Mr. Pattison's appointment to the Historical Commission. We are fortunate that he is willing to serve our community in this important role and lend his dedication and commitment to the commission and its work.

Very truly yours,

A handwritten signature in black ink, appearing to read "Kim Driscoll", written in a cursive style.

Kimberley Driscoll
Mayor
City of Salem



CITY OF SALEM, MASSACHUSETTS

Kimberley Driscoll
Mayor

June 28, 2018

Honorable Salem City Council
Salem City Hall
Salem, Massachusetts 01970

Ladies and Gentlemen of the City Council:

I reappoint, subject to City Council confirmation, Ms. Helen Sides, of 35 Broad Street, to the Salem Planning Board for a term of five years to expire June 28, 2023.

I enthusiastically recommend confirmation of her reappointment to the Planning Board and ask that you join me in thanking her for her continued dedicated service and commitment to our community.

Very truly yours,

A handwritten signature in cursive script that reads "Kim Driscoll".

Kimberley Driscoll
Mayor
City of Salem



CITY OF SALEM, MASSACHUSETTS

Kimberley Driscoll
Mayor

June 28, 2018

Honorable Salem City Council
Salem City Hall
Salem, Massachusetts 01970

Ladies and Gentlemen of the City Council:

I reappoint, subject to City Council confirmation, Mr. Mike Duffy, of 1 Warren Court, and Mr. Jimmy Tsitsinos, of 55 Lawrence Street, to the Salem Zoning Board of Appeals, for terms to expire on July 1, 2022, and July 1, 2021 respectively.

I enthusiastically recommend confirmation of their reappointment to the ZBA and ask that you join me in thanking them both for their continued dedicated service and commitment to our community.

Very truly yours,

A handwritten signature in cursive script that reads "Kim Driscoll".

Kimberley Driscoll
Mayor
City of Salem



2018 JUN 26 PM 2: 26

CITY CLERK
SALEM, MASS.

CITY OF SALEM, MASSACHUSETTS

Kimberley Driscoll
Mayor

June 28, 2018

Honorable Salem City Council
Salem City Hall
Salem, Massachusetts 01970

Ladies and Gentlemen of the City Council:

I am very pleased to appoint Chris Nagle, of 11 Warren Street #2, to the Salem Disabilities Commission to complete the remainder of a three-year term to expire December 3, 2018, previously held by Stephen Dwyer. I hope you will join me in thanking Mr. Dwyer for his service on the Commission.

Mr. Nagle is a software engineer by profession, but as a blind person living in Salem, as well as the parent of two children with visual impairment, he more importantly brings a personal perspective on the Commission's important work. Mr. Nagle routinely attends Commission meetings as a member of the public and contributes the group's discussions already. As a person living with a disability himself, I believe Mr. Nagle would be a dedicated and effective member of the Commission. He would bring a passion for advocating for equal access and, through his professional work, an attention to detail and problem solving.

I strongly recommend confirmation of Mr. Nagle to the Disabilities Commission. We are fortunate that he is willing to serve our community in this important role and lend his expertise and dedication to this board and its work.

Very truly yours,

A handwritten signature in black ink that reads "Kimberley Driscoll".

Kimberley Driscoll
Mayor
City of Salem



CITY OF SALEM

In City Council,

June 28, 2018

Ordered:

That the sum of Sixty-Four Thousand Six Hundred and Eighty-Five Dollars (\$64,685.00) is hereby appropriated from the "Fund Balance Reserved for Appropriation – Free Cash" account (1-3245) to the Short Term CIP Fund (20003-584618) to be used for the repair of the Salem Willows Pier in accordance with the recommendation of Her Honor the Mayor.



CITY OF SALEM, MASSACHUSETTS

Kimberley Driscoll
Mayor

June 28, 2018

Honorable Salem City Council
Salem City Hall
Salem, Massachusetts 01970

Ladies and Gentlemen of the City Council:

The enclosed Order appropriates \$64,685 from our free cash balance to help carry out the repair work of the Salem Willows pier, which was heavily damaged by severe storms this past spring.

In order for this work to begin as soon as possible so the pier can be reopened to the public, I recommend adoption of the enclosed Order.

Very truly yours,

A handwritten signature in cursive script, reading "Kim Driscoll".

Kimberley Driscoll
Mayor
City of Salem



CITY OF SALEM, MASSACHUSETTS
PARK, RECREATION & COMMUNITY SERVICE
5 Broad Street, Salem MA 01970
Tel. (978) 744-0180/(978) 744-0924
Fax (978) 744-7225
pobrien@salem.com

Kimberley Driscoll
MAYOR

Trish O'Brien
Superintendent

MEMORANDUM

June 26, 2018

To: Mayor Driscoll

From: Patricia O'Brien, Superintendent Parks, Recreation and Community Services

Re: Request for free cash

This memo is prepared to request funds from free cash in the amount of \$64,685 for the repair of the Salem Willows Pier. The pier was damaged as a result of the two winter coastal storms.

Thank you for your consideration.

Sincerely,

A handwritten signature in black ink, appearing to read "Trish O'Brien".

Trish O'Brien
Superintendent Parks, Recreation and Community Services

CITY OF SALEM - Finance Department
Free Cash, W & S R/E, R/Res & Budget Transfer Request Form

From: PARK, Rec's Com Ser. [Signature] 6/26/18
 Department Department Head Authorizing Signature Date

Budget or R/Res Budget Amt: _____
Transfers To: _____ Desc: _____ Balance: _____
 (Org/Object)
 From: _____ Desc: _____ Balance: _____
 (*Note - Please include letter to Mayor for Transfers from different Personnel & Non-personnel lines)
 Current Balance in Receipts Reserved Fund Above (if applicable) - \$ _____ Date: _____

Free Cash or To: CIP - Remot Rep Desc: Fund 2000 Budget Amt: _____
Retained Earnings (W/S) (Org/Object) Balance: _____
Raise & Appropriate
 Please circle one

Amount Requested: \$ 64,685
Reason (Be Specific) For repair to the Salem Willows Pier

For Finance Department and Mayor's Use Only:

_____ Budget Transfer _____ Mayor Approval _____ City Council Approval
 _____ Free Cash Appropriation - City Council Approval - Gen Fund \$ _____
 Free Cash Balance
 _____ R/E Appropriation - Water \$ _____ R/E Appropriation Sewer \$ _____
 R/E Balance R/E Balance
 _____ Receipts Reserve - City Council Approval \$ _____
 R/Res Fund Balance
 _____ Raise & Appropriate _____ Other
[Signature]
 Finance Director

Recommendation: _____ Approved _____ Denied

Completed: Date: _____ By: _____ CO # _____ JE#: _____ Transfer #: _____

CITY OF SALEM
Capital Outlay Expenditure Request Form

To: MAYOR

From Department: Part Rec Date: 6/26/18

Expense Line To : 20003-586018 - Equipment

Amount:

Description:

Expense Line To : 20003-584618 - Renovations & Repairs

Amount:

Description: Repair to Salem Willows Pier

For Finance Dept and Mayor's Use Only:

City Council Approval

Recommendation:

Approved Denied

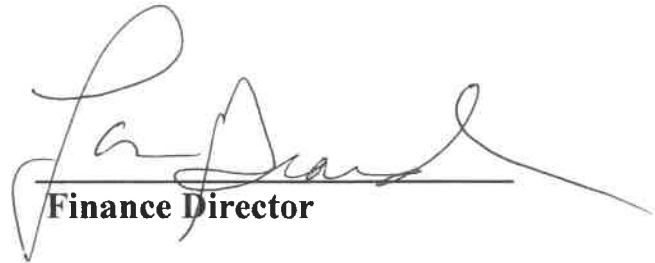

Finance Director

Mayor

Processed: Date: _____ **By:** _____

CO # _____ **JE#** _____ **Trans #** _____

BID FORM

ITEM 1:

The undersigned agrees to perform all work specified in this Invitation for Bids, for the following total price of:

\$ 56,810.00
(in figures)

Bid Prices must remain firm for the length of the contract.

UNIT PRICES FOR ADDITIONAL LUMBER NEEDED (ADD/DEDUCT)

Quantities listed are estimates only and are provided here for bidding purposes only. See Section 3.2, "Rule for Award" for further information relative to the below unit prices.

<u>ITEM</u>	<u>UNIT PRICE</u>	<u>QUANTITY</u>	<u>TOTAL</u>
2. 3x12x22 Decking	<u>\$ 275.00</u>	20	<u>\$ 5,500.00</u>
3. 3x8 PT Side plate (Kicker)	<u>80.00</u>	10	<u>800.00</u>
4. 2x8 PT Rail System	<u>65.00</u>	15	<u>975.00</u>
5. 2x6 PT Hand Rail Caps	<u>60.00</u>	10	<u>600.00</u>
TOTAL (ITEMS 2 - 5):			<u>\$ 7,875.00</u>

GRAND TOTAL (ITEMS 1 - 5):

\$ 64,685.00
(in figures)

SIXTY FOUR THOUSAND SIX HUNDRED EIGHTY FIVE DOLLARS
(in words)

By:

AUTHORIZED SIGNATURE

LAWRENCE WHITE
PRINT/TYPE NAME

PRESIDENT
TYPE/PRINT TITLE





CITY OF SALEM

In City Council,

June 28, 2018

Ordered:

That the sum of Thirty-Three Thousand Dollars (\$33,000.00) is hereby appropriated from the "Fund Balance Reserved for Appropriation – Free Cash" account (1-3245) to the Treasurer Credit Card Fee account (11452-5709) in accordance with the recommendation of Her Honor the Mayor.



CITY OF SALEM, MASSACHUSETTS

Kimberley Driscoll

Mayor

June 28, 2018

To the City Council
City Hall
Salem, Massachusetts

Ladies and Gentlemen of the Council:

Enclosed herewith is a request to transfer Thirty-Three Thousand Dollars (\$33,000.00) from the "Fund Balance Reserved for Appropriation – Free Cash" account (1-3245) to the Treasurers Credit Card Fee account 11452-5709).

This request is necessary to cover the costs for credit card fees for March.

I recommend passage of this accompanying order.

Sincerely,

A handwritten signature in cursive script that reads "Kim Driscoll".

Kimberley Driscoll
Mayor



KIMBERLEY DRISCOLL
MAYOR

KATHLEEN MCMAHON
TREASURER

CITY OF SALEM, MASSACHUSETTS

OFFICE OF THE TREASURER
120 WASHINGTON STREET, 2ND FLOOR
TEL. (978) 619-5635
FAX (978) 740-3086
KMCMAHON@SALEM.COM

June 14, 2018

Mayor Kimberley Driscoll
City of Salem
93 Washington Street
Salem, MA 01970

Mayor Driscoll,

I am writing to request an increase in appropriation of \$33,000 to Credit Card Fees. The increase is requested as a result of new kiosks in the parking garages and an increase in usage of the smart meters. The new kiosks have more credit card usage and less cash.

The City has a nominal per transaction fee from First Data. The increase in credit card payments results in an increase in interchange fees that is regulated by the various credit cards, a fee First Data cannot control.

The increase is needed to cover two invoices from IPS Group. The City has 135 Smart Meters. These meters are provided by IPS Group. The monthly charges include a fee for pay by cell feature, a management system fee for single space parking meters, secure gateway/wireless data fee for single space parking meters, a sensor base data fee and a credit card transaction fee for single space parking meters.

The pay by cell feature and the credit card transaction fee is based on usage and the usage has consistently increased every month. The FY 19 budget does reflect an increase in the appropriation due to usage and collections.

If you have any questions please let me know,

Sincerely,

A handwritten signature in cursive script that reads "Kathleen".

Kathleen McMahon

**CITY OF SALEM, MASSACHUSETTS
FY 2018 FREE CASH SUMMARY**

6/14/2018
4:31 PM

Description	Date		C.O. #	Approved Free Cash	Reason
	To Council	To Council			

CERTIFIED FREE CASH

4,922,937.00

20% To Stabilization	11/16/17	11/16/17	649	(984,587.40)	Free Cash transfer per Finance Policies
20% to CIP	11/16/17	11/16/17	649	(984,587.40)	Free Cash transfer per Finance Policies
5% to OPEB	11/16/17	11/16/17	649	(246,146.85)	Free Cash transfer per Finance Policies
Board of Health - Overtime	11/16/17	11/16/17	655	(2,000.00)	Unanticipated additional weekend hours for pop-up events
COA-Printing & Binding	11/16/17	11/16/17	652	(20,000.00)	Expenses for Salem for All Ages
Electrical - Street Lighting	12/07/17	12/07/17	698	(12,000.00)	To hire contractor to cover inspections for employee out on medical leave
Offset Tax Rate	12/07/17	12/07/17	692	(1,694,429.00)	Free cash to offset tax rate
Planning Contracted Services	12/07/17	12/07/17	699	(2,000.00)	Research, data input and analysis for green communities initiatives
Planning Overtime	01/11/18	01/11/18	11	(5,200.00)	Unanticipated OT needed for document handling for City Hall Annex move
HR Overtime	01/11/18	01/11/18	11	(1,800.00)	Unanticipated OT needed for document handling for City Hall Annex move
Building Insp Overtime	01/11/18	01/11/18	11	(1,200.00)	Unanticipated OT needed for document handling for City Hall Annex move
Health Overtime	01/11/18	01/11/18	11	(1,800.00)	Unanticipated OT needed for document handling for City Hall Annex move
Veterans In-State Travel	01/25/18	01/25/18	64	(1,500.00)	Unanticipated training for Veterans Administrations Claims
City Council Advertising	01/25/18	01/25/18	62	(28,000.00)	Additional funds needed due to increased volume of advertising needed for council.
Planning Contracted Services	01/25/18	01/25/18	63	(2,500.00)	City share of North Shore Mobility Study
Police Medical	01/25/18	01/25/18	60	(45,000.00)	Additional funds needed for police medical expenses
DPS Equipment Lease	01/25/18	02/08/18	66	(106,696.00)	Funds needed for DPS Equipment Lease
DPS Equipment Repairs	01/25/18	02/08/18	68	(18,500.00)	Additional Funds needed for DPS equipment repairs
Electrical Street Lighting	02/08/18	02/08/18	102	(12,000.00)	Additional Funds needed to cover for employee out on medical leave
DPS Spray/Tree Removal	03/08/18	03/08/18	175	(48,000.00)	Tree maintenance, removals and plantings city-wide.
Retirement Stabilization	03/08/18	03/08/18	177	(18,000.00)	Additional funds needed to contractual buybacks
Retirement Stabilization	03/22/18	03/22/18	203	(250,000.00)	Additional funds needed for retirement buybacks for remainder of 2018
DPS Contracted Services	04/12/18	04/12/18	223	(30,000.00)	Additional Funds needed for spring 2018 mowing of parks and bikepaths
Collector's FT Salaries	04/12/18	04/12/18	225	(12,000.00)	Additional funds to cover pay for temp while 2 employees out on maternity leave
Mayor Contracted Services	05/10/18				Funds needed for assessment center for new Fire Chief
City Council Advertising	05/24/18	05/24/18	328	(20,000.00)	Additional funds needed due to increased volume of advertising needed for council.
City Council Printing and Binding	05/24/18	05/24/18	328	(10,000.00)	Additional funds needed due to pay Muni code for additional ordinances
Police Medical	05/24/18	05/24/18	329	(17,640.00)	Additional funds needed for police medical expenses
Fire Medical	05/24/18	05/24/18	327	(52,397.67)	Additional funds needed for Fire medical expenses
School - Bentley Roof	05/24/18				Additional funds needed for Bentley Roof replacement
Purchasing Telephone	06/14/18				Additional funds needed for telephones for remainder of year
Planning Contracted Services	06/14/18				Funds needed for REI for Winter Island Hanger
Treasurer Credit Card Fees	06/28/18				Funds needed for credit card fees for parking meters and kiosks

TOTAL FREE CASH USED
BALANCE

(144,706.00)
150,246.68

(4,627,984.32)
294,952.68

CITY OF SALEM – Finance Department

Free Cash, W & S R/E, R/Res & Budget Transfer Request Form

From: Treasury Department Kathleen McMahon Department Head Authorizing Signature 6/14/18 Date

Budget or R/Res

Transfers To: _____ Desc: _____ Budget Amt: _____
(Org/Object) Balance: _____

From: _____ Desc: _____ Budget Amt: _____
 Balance: _____

(*Note - Please include letter to Mayor for Transfers from different Personnel & Non-personnel lines)

Current Balance in Receipts Reserved Fund Above (if applicable) - \$ _____ Date: _____

Free Cash or Retained Earnings (W/S) To: 11452-5709 Desc: Credit Card Fees Budget Amt: \$ 102,239.00
(Org/Object) Balance: \$ 6,453.00
 Please circle one

Amount Requested: \$ 33,000.00

Reason (Be Specific) Credit Card fees for March - \$6,215.77 April - \$7,758.97 May \$10,523.33 and an estimate of \$11,000.00 for June have not been warranted. There are two IPS invoices that have not been paid, totaling \$3,858.14.

For Finance Department and Mayor's Use Only:

_____ Budget Transfer _____ Mayor Approval _____ City Council Approval

_____ Free Cash Appropriation – City Council Approval – Gen Fund \$ 294,952.68
Free Cash Balance

_____ R/E Appropriation – Water \$ _____ R/E Appropriation Sewer \$ _____
R/E Balance R/E Balance

_____ Receipts Reserve – City Council Approval \$ _____
R/Res Fund Balance

_____ Raise & Appropriate _____ Other

Recommendation: _____ Approved _____ Denied

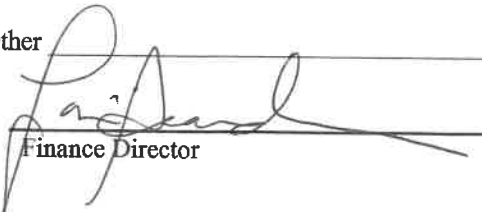
Finance Director

Completed: Date: _____ By: _____ CO # _____ JE#: _____ Transfer #: _____



CITY OF SALEM

In City Council, June 28, 2018

Ordered:

That the sum of Eighteen Thousand Three Hundred and Nine Dollars and Seventeen Cents (\$18,309.17) in the "Retirement Stabilization Fund-Vacation/Sick Leave Buyback" account (83113-5146) to be expended for the FY 2018 contractual buybacks listed below in accordance with the recommendation of Her Honor the Mayor.

Name	Department	Amount
Elizabeth Melin	School	18,309.17
		18,309.17



CITY OF SALEM, MASSACHUSETTS

**Kimberley Driscoll
Mayor**

June 28, 2018

To the City Council
City Hall
Salem, Massachusetts

Ladies and Gentlemen of the Council:

Enclosed herewith is a request for an appropriation of Eighteen Thousand Three Hundred and Nine Dollars and Seventeen Cents (\$18,309.17) appropriated in the "Retirement Stabilization Fund-Vacation/Sick Leave Buyback" account (83113-5146) to be expended for the FY 2018 Contractual School buyback listed below:

NAME	DEPARTMENT	AMOUNT
Elizabeth Melin	School	18,309.17

I recommend passage of the accompanying Order.

Very truly yours,

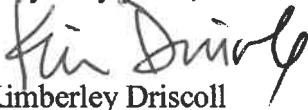
Kimberley Driscoll
Mayor



CITY OF SALEM, MASSACHUSETTS

HUMAN RESOURCES
120 WASHINGTON STREET
TEL. (978) 745-9595 EXT. 5630
FAX (978) 745-7298

KIMBERLEY DRISCOLL
MAYOR

LISA B. CAMMARATA
DIRECTOR OF HUMAN RESOURCES

MEMORANDUM

TO: Laurie Giardella, Finance Director
DATE: May 9, 2018
RE: Retirement Stabilization Fund

Attached is a PAF for a former employee of the Salem Public Schools.

This former employee is contractually entitled to the following amount of sick leave and vacation buy back.

Elizabeth Melin

29.457 vacation days @ \$153.27 per day	\$4,514.87
90 sick days @ \$153.27 per day	\$13,794.30
Total:	\$18,309.17

In accordance with the July 2008 Policy, I am requesting you verify the availability of the funds from the Retirement Stabilization Fund, prepare the Council Order, and continue the process in order that my staff can input the information in MUNIS and issue payments to this former employee upon Council approval.

Thank you for your cooperation, and if you should have any questions, please do not hesitate to contact me.

IBC

Finance Director



CITY OF SALEM

In City Council,

Ordered:

June 28, 2018

To accept in-kind services, labor and materials from Brennan Construction, Inc. and the Brennan Family in the amount of Twenty-One Thousand, Eight Hundred and Thirty-Two Dollars and Fifty Cents (\$21,832.50) for the reconstruction project of the Salem Skate Park memorializing Ryan Adam Brennan. These in-kind services are listed on the attached letter and request you accept this donation for the City of Salem with the recommendation of Her Honor the Mayor.



CITY OF SALEM, MASSACHUSETTS

Kimberley Driscoll
Mayor

June 28, 2018

Honorable Salem City Council
Salem City Hall
Salem, Massachusetts 01970

Ladies and Gentlemen of the City Council:

The enclosed Order accepts a gift of \$21,832.50 worth of donated labor, materials, and work from Brennan Construction of Salem, for the forthcoming upgrades to the Ryan Brennan Memorial Skatepark at Gallows Hill. A complete list of the donated items and in-kind work is itemized in the enclosed letter.

Please join me in expressing our gratitude to Rich, Wendy, Katie, Keith, and Sean Brennan for their generosity in supporting this important project. I recommend adoption of the enclosed Order.

Very truly yours,

A handwritten signature in black ink, appearing to read "Kim Driscoll".

Kimberley Driscoll
Mayor
City of Salem

105 Mason Street
Salem, MA 01970



MAIN: 978-741-4721
FAX: 978-744-9103

6/22/2018

Jenna Ide
Director of Capital Projects and Municipal Operations
City of Salem
98 Washington Street
Salem MA, 01970

Dear Jenna Ide:

Brennan Construction, Inc. and the Brennan Family would like to donate the following services to the reconstruction project of the Salem Skate Park memorializing our own Ryan Adam Brennan. We've included a cost estimate of each of the proposed donated services, which for each activity include labor and equipment.

ITEM #	Description	QTY	UOM	EST U.P.	EST COST
100	MOBILIZATION	1.00	LS	\$ 1,500.00	\$ 1,500.00
200	SITE PREPARATION & EARTHWORK	8,000.00	SF	\$ 0.90	\$ 7,200.00
1000	DEMO EXISTING STRUCTURES	1.00	LS	\$ 3,500.00	\$ 3,500.00
2000	REMOVE EXISTING ASPHALT AND SIDEWALKS	120.00	TON	\$ 22.50	\$ 2,700.00
3000	STRIP AND STOCKPILE TOPSOIL	1.00	LS	\$ 340.00	\$ 340.00
4000	INSTALL ZURN DRAIN	1.00	EA	\$ 450.00	\$ 450.00
4500	INSTALL 6" PVC PIPE	100.00	LF	\$ 13.20	\$ 1,320.00
4600	INSTALL FLARED END SECTION	1.00	EA	\$ 450.00	\$ 450.00
4700	INSTALL AREA DRAIN	1.00	EA	\$ 450.00	\$ 450.00
4800	INSTALL INFILTRATION TRENCH	25.00	LF	\$ 33.90	\$ 847.50
4900	INSTALL 3" DRAIN TILE	100.00	LF	\$ 4.25	\$ 425.00
6000	PREPARATION OF WALKWAY SUBGRADE/SUBBASE	700.00	SF	\$ 1.90	\$ 1,330.00
7000	PREPARATION OF PAVER SUBGRADE/SUBBASE	400.00	SF	\$ 3.30	\$ 1,320.00

The Brennan Family is very thankful for being given the opportunity to be a part of this project whether it be design consideration, memorial or construction. Please feel free to contact us should you require any additional information. We're excited to help any way we can!

**Very and Truly Yours,
Sean Brennan
Vice President**





CITY OF SALEM

In City Council, June 28, 2018

Ordered:

The daily rate for parking in the South Harbor Parking Garage and Museum Place Parking Garage shall be \$5.00 on July 4, 2018. The daily rate commences at 2:00 a.m. and concludes the following day at 1:59 a.m.



CITY OF SALEM, MASSACHUSETTS

Kimberley Driscoll
Mayor

June 28, 2018

Honorable Salem City Council
Salem City Hall
Salem, Massachusetts 01970

Ladies and Gentlemen of the City Council:

The enclosed Order sets the July 4 rate at the Museum Place and South Harbor parking garages at \$5 for the day.

This is consistent with what has been done in the past and helps make it possible for Salem families and residents to come downtown and enjoy the annual Independence Day celebrations. I recommend adoption of the enclosed Order.

Very truly yours,

A handwritten signature in cursive script that reads "Kim Driscoll".

Kimberley Driscoll
Mayor
City of Salem

City of Salem

In the year Two Thousand and Eighteen

An Ordinance to amend the Ordinance relative to the Commission on Disabilities

Be it ordained by the City Council of the City of Salem, as follows:

Section 1. Section 2-927. - Appointment and terms of members; filling vacancies. – is hereby amended by deleting the word “seven” and replacing it with the word “nine” as it appears in this first sentence of this section.

Section 2. This Ordinance shall take effect as provided by City Charter.



CITY OF SALEM, MASSACHUSETTS

Kimberley Driscoll
Mayor

June 28, 2018

City Council
City Hall
Salem, MA 01970

Ladies and Gentlemen of the Council:

Enclosed herewith is an Ordinance to amend an Ordinance relative to the Commission on Disabilities. Due to an oversight in 2007 when the commission membership was increased from seven to nine in Section 2-926, Section 2-927 was not changed.

Thank you for your consideration of this matter.

Sincerely,

A handwritten signature in cursive script, appearing to read "Kim Driscoll", is written in black ink.

Kimberley Driscoll
Mayor



CITY OF SALEM

In City Council, June 28, 2018

Ordered:

The parking rates for municipal parking garages and lots, with the exception of special event rates, shall be as follows:

Location	Type- Hourly Rate Unless Otherwise Noted	Traffic & Parking Commission Recommendation
Museum Place Garage	Garage	\$1.25
	Garage – Monthly Pass	\$80.00 (resident rate \$70.00)
South Harbor Garage	Garage	\$0.75
Church Street Lots	Kiosk	\$1.50
Crombie Street Lot	Kiosk	\$1.00
Depot Lot at MBTA	Kiosk – Day	\$4.00
Central Street	Meters	\$1.50
Crombie Street	Meters	\$1.00
Derby Street	Meters	\$1.00
Dodge Street	Meters	\$1.00
Dodge Street Court	Meters	\$1.00
Essex Street	Meters	\$1.50
Front Street	Meters	\$1.50
Hawthorne Boulevard	Meters	\$1.00
Klopp Alley/Front Street Lot	Meters	\$1.00

Lafayette Street (Zone 264)	Meters	\$1.00
New Derby Street	Meters	\$1.00
Salem Green Lot	Meters	\$1.50
Sewall Street Lot	Meters	\$1.00
South Harbor Garage (Level 1 Meters)	Meters	\$0.75
Washington Street	Meters	\$1.50
Washington Street (Upper)	Meters	\$1.00
Riley Plaza Lot	Monthly Pass	\$35.00
Museum Place Garage (October weekends and Halloween)	Garage	0-1 hour - \$5; 1-2 hours - \$10; 2-4 hours - \$20; 4-8 hours - \$25; 8-12 hours - \$30; 12-24 hours - \$35
South Harbor Garage (October weekends and Halloween)	Garage	

Be it further Ordered, parking rates at locations not listed above shall remain at the current rate.



CITY OF SALEM, MASSACHUSETTS

Kimberley Driscoll
Mayor

June 28, 2018

Honorable Salem City Council
Salem City Hall
Salem, Massachusetts 01970

Ladies and Gentlemen of the City Council:

Enclosed you will find an Order and an Ordinance reflecting changes recommended by the Traffic and Parking Commission to the parking rates at our garages, some surface lots, and at on-street meters. The Commission held a series of three public meetings on these proposals and I would like to thank them for their diligence and careful consideration of this issue.

Following several months of comprehensive analysis of utilization and comparable community rates, the staff of the Traffic and Parking Department prepared a set of proposed changes, which you will see in the "Department's Proposed Rate" column of the enclosed table. Salem's parking rates have been unadjusted for almost a decade, one of the few City fees to be so unmodified, even though the bulk of these charges are borne by non-residents and despite the fact that over the last few years we have invested heavily in our parking facilities, repaving the Church Street lots, installing more kiosks and other technologies to add convenience for parkers, overhauling the Museum Place Garage stairwells, electrical and life safety systems, and, shortly, the elevators, and more. To carry out large scale improvements and maintenance efforts such as these, without corresponding adjustments to the revenues directly collected at those facilities, is not sustainable in the long term.

No parking rate changes are proposed for the 265 spaces on Church Street, Congress Street, Federal Harbor Street, Lafayette Street in zones 265 and 267, Lynde Street, Norman Street, the Riley Plaza lot meters, Washington Street at Mill Hill, the Universal Steel lot, and the Old Salem Jail lot.

The proposed rates are directly based on utilization and desirability of parking in various locations, which has changed considerably since most of the current rates were adopted almost a decade ago through our old parking plan. As called for in that study, higher demand and utilized parking should incur a higher rate, where less valuable parking locations benefit from a lower rate that encourages greater utilization.

Following the public meetings by the Commission, they issued their proposed recommendations, which you can find in the column entitled "Traffic & Parking Commission's Recommendation." These are the recommendations reflected in the enclosed Order, as well.

On the matter of enforcement hours, the Commission is recommending the enclosed Ordinance, which would extend the current enforcement end time of 6:00 p.m. to the 8:00 p.m. time recommended by the original Parking Plan completed in 2010. I believe this is a reasonable proposal and will help ensure more turnover of vehicles and availability of parking for downtown customers and diners during the busy evening hours. However, I believe the City should entertain the idea of extending enforcement ours to Sunday afternoons for non-residents in our kiosk parking lots (Church Street, Crombie Street, Depot, Universal Steel, and Old Salem Jail). I would propose the Council adopt an amendment to the enclosed Ordinance to include this. The additional revenues would be entirely borne by non-residents and would more than offset the additional personnel costs for adding enforcement for the day.

On the matter of resident rates, the department's original proposal included establishing a discounted parking rate for Salem residents in certain locations. Vehicles registered in Salem would be eligible for this discounted resident rate at pay-by-plate parking facilities (e.g. Church Street lots, Crombie Street lot, Depot lot, and more as the City continues to replace old meters with the newer pay-by-plate kiosks) and will continue to be able to park for free on October weekends in the Church Street and Depot lots. While the Commission's recommendations do not include this, I think it is important to continue to provide this as a benefit to our residents who wish to come downtown and patronize our downtown businesses. Therefore, I would suggest the Council adopt an amendment to the Order instituting the resident parking rate at the Church Street and Crombie Street lots in an amount equivalent to today's parking rate in those lots. In that way, residents parking in these lots will incur no additional costs to do so.

In our garages, the Commission felt it was important to keep rates lower than on-street meter spaces, to encourage longer term parking in the garages. I respect that recommendation and believe that it makes sense, however the high utilization figures from the South Harbor Garage on weekends strongly argues for a different rate in that facility on weekends. I would recommend that, while the Commission's proposed rate of \$0.75 per hour be adopted for weekdays, the weekend rate in the South Harbor Garage ought to be \$1.50 per hour.

Downtown residents who purchase a garage pass as a requirement of their unit's deed will continue to pay the same price for those passes, though other monthly pass rates will also be adjusted to reflect increased demand and utilization at monthly and yearly parking facilities. As the October weekend parking rate in private parking lots has escalated significantly, we believe it is appropriate to stay competitive and not under-value our garages. The Commission believed a variable October weekend garage rate based on duration was more fair than a flat amount. While I agree with that, I believe their recommendation for six different rates could be simplified to just two rates: under 2 hours is \$10 and over 2 hours is \$30. Salem residents would continue to be able to park for free on October weekends in the depot lot and the Church Street lot.

I have outlined all of my recommendations in the column in the attached table entitled "Mayor's Recommendations."

In regard to on-street meters, the proposed rate structure would replace the existing six tier system with a simplified three tier system: \$1.50, \$1.00 and \$0.50 per hour. Parking most in demand and that caters primarily to visitors would fall into the highest tier, convenience parking more appealing to residents would fall into the middle tier, and areas where retail continues to struggle would remain at \$0.50. These rates reflect the increased parking demand and utilization in the various areas of Salem's downtown. These changes will help encourage shoppers and diners to park in the lower utilized. These rates are recommended by the Department, the Commission, and by myself.

Altogether these changes will generate additional revenues for the City, primarily from visitors and other non-residents, which will make manageable increased investment in a number of areas, including in garage maintenance, additional parking enforcement personnel for neighborhoods, and the debt payments for lot and garage upgrades, road repaving, sidewalk repairs, and more. In particular, we anticipate investing in our downtown lots that will both improve maintenance and add parking spaces. Plans for re-striping the Church St. Lot have been completed and will be implemented this year and we hope to prepare plans to do the same at Riley Plaza, as well. Most importantly, however, it will help us better manage parking in our downtown by improving utilization where it is most needed, encouraging space turnover and availability, and reducing circulating traffic seeking parking.

Ultimately, our goal is to also encourage mode shift in order to generate fewer private vehicle trips into our downtown. To that end we are continuing to pursue the South Salem commuter rail stop, successfully received a \$3.4 million federal grant to add a second passenger ferry, secured private sponsors to expand our bike share system to dozens of more racks and added more bikes, received state aid to design and stripe bike lanes throughout downtown later this year, are finalizing the intra-shuttle feasibility study, continued the free Salem Trolley rides for Salem residents for a sixth year, launched last year and intend to expand this year the October shuttle and expanded our harbor shuttle service to add a stop in Marblehead this year.

I recommend adoption of the enclosed Order and Ordinance in order to help better regulate on-street and off-street parking in our downtown areas, lessen traffic congestion, and bolster our downtown businesses. I look forward to working with you, the Traffic and Parking Commission members, our downtown residents, the business community, and all the other engaged stakeholders who have participated in this process to advance this important change. I am hopeful that you will take final action of these recommendations by your July 19 regular meeting, so we can begin to implement the approved changes as early as possible in the new fiscal year.

Very truly yours,

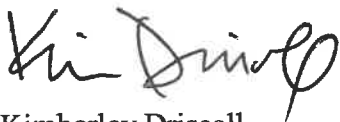

Kimberley Driscoll
Mayor
City of Salem

2018 Parking Rate Restructure Proposal

Location	Type	Current Rate	Department's Proposed Rate	Traffic & Parking Commission Recommendation	Mayor's Recommendation	
Enforcement Hours (by Ordinance)	Hours	8am-6pm	8am-6pm	8am-8pm	8am-8pm; Sundays in all kiosk lots (residents park free on Sundays)	
	Garage - Hourly	\$0.75	\$1.50 (resident rate \$1.00)	\$1.25	\$1.25	
Museum Place Garage	Garage - Monthly Pass	\$65.00	\$80.00 (resident rate \$70.00)	\$80.00 (resident rate \$70.00)	\$80.00 (resident rate \$70.00)	
	South Harbor Garage	Garage	\$0.25	\$1.50 (resident rate \$1.00)	\$0.75	\$0.75 weekdays; \$1.50 weekends
	Church Street Lots	Kiosk	\$1.00	\$1.50 (resident rate \$1.00)	\$1.50	\$1.50 (resident rate \$1.00)
	Crombie Street Lot	Kiosk	\$0.50	\$1.00 (resident rate \$0.75)	\$1.00	\$1.00 (resident rate \$0.50)
	Depot Lot at MBTA	Kiosk	\$4.00 per day	\$5.00 per day (resident rate \$4 per day)	\$4.00 per day	\$4.00 per day
	Central Street	Meters	\$0.75	\$1.50	\$1.50	\$1.50
	Crombie Street	Meters	\$0.75	\$1.00	\$1.00	\$1.00
	Derby Street	Meters	\$0.75	\$1.00	\$1.00	\$1.00
	Dodge Street	Meters	\$0.50	\$1.00	\$1.00	\$1.00
	Dodge Street Court	Meters	\$0.50	\$1.00	\$1.00	\$1.00
	Essex Street	Meters	\$0.75	\$1.50	\$1.50	\$1.50
	Front Street	Meters	\$0.75	\$1.50	\$1.50	\$1.50
	Hawthorne Boulevard	Meters	\$0.75	\$1.00	\$1.00	\$1.00
Klopp Alley/Front Street Lot	Meters	\$0.75	\$1.00	\$1.00	\$1.00	
Lafayette Street (Zone 264)	Meters	\$0.75	\$1.00	\$1.00	\$1.00	
New Derby Street	Meters	\$0.75	\$1.00	\$1.00	\$1.00	
Salem Green Lot	Meters	\$1.00	\$1.50	\$1.50	\$1.50	
Seawall Street Lot	Meters	\$0.75	\$1.00	\$1.00	\$1.00	
South Harbor Garage (Level 1 Meters)	Meters	\$0.25	\$1.50	\$0.75	\$1.00	
Washington Street	Meters	\$0.75	\$1.50	\$1.50	\$1.50	
Washington Street (Upper)	Meters	\$0.50	\$1.00	\$1.00	\$1.00	
Riley Plaza Lot	Monthly Pass	\$25.00 per month	\$35.00 per month	\$35.00 per month	\$35.00 per month	
Museum Place Garage (October weekends)	Garage			0-1 hour - \$5; 1-2 hours - \$10; 2-4 hours - \$20; 4-8 hours - \$25; 8-12 hours - \$30; 12-24 hours - \$35		
South Harbor Garage (October weekends)	Garage	\$20.00 per day	\$30 per day		0-2 hours: \$10; 2 hours and up: \$30	



City of Salem, Massachusetts
Traffic and Parking Commission

120 Washington Street, 3rd Floor
Salem, MA 01970
www.salem.com

Kimberley L. Driscoll, Mayor

Tanya Stepasiuk, Chair, Salem Traffic and Parking Commission

Tuesday, June 26, 2018

Salem City Council
93 Washington Street
Salem, MA 01970

Dear City Council,

On behalf of the Traffic and Parking Commission, included for consideration of the Salem City Council are an order and ordinance recommendation to restructure downtown parking rates.

Following extensive data collection over the last few months, the Traffic and Parking Department and Traffic and Parking Commission have been examining proposals to restructure downtown parking rates. The current parking rates were put into effect after the completion of the 2010 Salem Comprehensive Parking Plan. The City has undergone significant growth and change since that time, but parking rates have remained the same. The Parking Plan recommended that the City regularly monitor and update pricing, and we are overdue in this regard.

After careful consideration of available utilization data, and based on input from Traffic and Parking Department staff, residents, local businesses, and City Councillors, the Commission voted on June 20 to submit the attached order for the Council's consideration. In addition to proposed changes for some hourly rates, the Commission is also recommending the extension of enforcement hours from the current end time of 6:00pm Monday through Saturday to 8:00pm Monday through Saturday. This change would require increased enforcement staff time, but the Commission felt the cost would be more than made up for by the increased revenue potential, and that the extension more accurately reflects the core business hours in downtown. The Commission also recommends that a portion of this additional revenue go toward the hiring of additional part-time enforcement officers.

The Commission feels this proposal maintains the core concepts of the 2010 parking plan, while updating prices accordingly to reflect changing utilization patterns across the City. The Commission knows how important a safe, rational, fairly priced parking system is to the success of the City, and feels the proposed rate restructuring will more efficiently manage parking demand, and raise revenue to support critical investments in the City's parking infrastructure.

The Commission looks forward to working closely with the Council and the Mayor to finalize this rate restructuring process,

Sincerely,

A handwritten signature in black ink, appearing to read "Tanya Stepasiuk".

Tanya Stepasiuk
Chair, Salem Traffic and Parking Commission

City of Salem

In the year Two Thousand and Eighteen

An Ordinance to amend an ordinance relative to parking

Be it ordained by the City Council of the City of Salem, as follows:

Section 1. Chapter 42, Article V. Parking, Sec. 57 Parking Time Limited; Hours of Operation and Sec. 57A Parking Time Limited; Unmetered Zones are hereby amended by replacing the phrase “hours of 8:00 A.M. to 6:00 P.M.” as it appears in the first paragraph of these sections with the phrase “hours of 8:00 A.M. to 8:00 P.M.”

Section 2. This Ordinance shall take effect as provided by City Charter.



Comcast
David R. Flewelling
Specialist 2 Construction
9 Forbes Road, Suite 9B
Woburn, MA 01801
Cell - 617-279-7864
dave_flewelling@comcast.com

June 22, 2018

Ms. Ilene Simons
Salem City Clerk
City Hall
93 Washington Street
Salem, MA 01970

RE: 267 Highland Avenue
Grant of Location-Petition

Dear Ms. Simons:

Enclosed please find materials supporting Comcast request for a grant of location from the Salem City Council. The work associated with the attached petition is for the purpose of installing new underground conduit to provide service to number 267 Highland Avenue. For a detailed description of the work please refer to the attached construction plans.

I look forward to the opportunity to address this matter in further detail at the next Salem City Council Meeting. Should you have any questions or concerns, please feel free to contact me at (617) 279-7864.

Sincerely,

A handwritten signature in black ink, appearing to read "David R. Flewelling", is written over the typed name.

David R. Flewelling
Comcast
Specialist 2, Construction

Enclosure (5)

ORDER FOR CONDUIT LOCATION

In the City Council for the City of Salem, Massachusetts.

ORDERED:

That permission be and hereby is granted to Comcast Cable Communications Management LCC., to lay and maintain underground conduits and manholes, with the wires and cables to be placed therein, under the surface of the following public way or ways as requested in petition of said Company dated June 22, 2018

Highland Avenue: Proposing to excavate and place (1) 2" PVC conduit 15'± from the existing utility pole number 63 to number 267 Highland Avenue. As shown on the attached construction plans.

Substantially as shown on plan, filed with said petition.

Also that permission be and hereby is granted said Comcast to lay and maintain underground conduits, manholes, cables and wires in the above or intersecting public ways for the purpose of making connections with such poles and buildings as it may desire for distributing purposes.

The foregoing permission is subject to the following conditions:

1. The conduits and manholes shall be of such materials and construction and all work done in such manner as to be satisfactory to the City Council or to such officers as it may appoint to the supervision of the work.

2. Said Company shall indemnify and save the City harmless against all damages, costs and expense whatsoever to which the City may be subjected in consequence of the acts or neglect of said Company, its agents or servants, or in any manner arising from the rights and privileges granted it by the City.

3. In addition said Company shall, before a public way is disturbed for the laying of its wire or conduits, execute its bond in a penal sum of One Hundred Thousand Dollars (\$100,000) (reference being had to the bond already on file with said City) conditioned for the faithful performance of its duties under this permit.

4. Said Company shall comply with the requirements of existing by-laws and such as may hereafter be adopted governing the construction and maintenance of conduits and wires, so far as the same are not inconsistent with the laws of the Commonwealth.

I hereby certify that the foregoing order was adopted at a meeting of the City Council for the City of Salem, Massachusetts, held on the _____ day of _____ 2018.

(over)

City Clerk

We hereby certify that on _____, 2018, at _____ o'clock M., at Salem, Massachusetts a public hearing was held on the petition of the Comcast for permission to lay and maintain underground conduits, manholes and connections, with the wires and cables to be placed therein, described in the order herewith recorded, that we mailed at least seven days before said hearing a written notice the time and place of said hearing to each of the owners of real estate determined by the last preceding assessment for taxation along the ways parts of ways upon which the Company is permitted to construct the lines said Company under said order. And that thereupon said order was duly adopted.

Salem City Council; Salem, Massachusetts

CERTIFICATE

I hereby certify that the foregoing is a true copy of a location order, and certificate of hearing with the notice adopted by the City Council for the City of Salem, Massachusetts, on the _____ day of _____ 2018, recorded with the records of location orders of said City, Book _____, Page _____. This certified copy is made under the provision of Chapter 166 of General Laws and any additions thereto or amendments thereof.

Attest:

City Clerk

PETITION OF COMCAST FOR LOCACTION FOR CONDUITS AND MANHOLES

To the City Council for the City of Salem, Massachusetts:

Respectfully represents Comcast Cable Communications Management LLC., a company incorporated for the distribution of telecommunications services, that it desires to construct a line for such telecommunications under the public way or ways hereinafter specified.

Highland Avenue: Proposing to excavate and place (1) 2" PVC conduit 15'± from the existing utility pole number 63 to number 267 Highland Avenue. As shown on the attached construction plans.

Wherefore, your petition prays that, after due notice and hearing as provided by law, the City Council may by Order grant your petitioner permission to construct, and a location for, such a line of conduits and manholes with the necessary wires and cables therein, said conduits and manholes to be located, substantially as shown on the plan made by Comcast dated June 14, 2018 and filed here with, under the following public way or ways of said City of Salem.

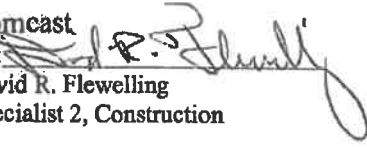
Comcast
By: 
David R. Flewelling
Specialist 2, Construction

Dated this June 22, 2018

City of Salem Massachusetts

Received and filed _____, 2018

Subject Parcel ID: b

Subject Property Location:

ParcelID	Location	Owner	Co-Owner	Mailing Address	City	State	Zip
08-0025-0	259 HIGHLAND AVENUE	SWAMSCENT REALTY LLC	C/O LBK,LLC	822 LEXINGTON ST 2nd FL	WALTHAM	MA	02452
08-0027-0	267 HIGHLAND AVENUE	HIGHLANDER PLAZA REALTY TRU	C/O JAGER MANAGEMENT I	261 OLD YORK RD STE 814	JENKINTOWN	PA	19046
08-0126-0	1 15 TRADERS WAY	HIGHLANDER PLAZA REALTY TRU	C/O JAGER MANAGEMENT I	261 OLD YORK RD STE 814	JENKINTOWN	PA	19046

Parcel Count: 3

End of Report

GENERAL NOTES

1. THE CONTRACTOR SHALL MAINTAIN A SEPARATION OF 24 INCHES WITH 4 THE CONDUCTORS SHALL HAVE ALL APPROPRIATE FOR THE LOCATION AND ABANDONED FOR OLD ELECTRIC. TELEPHONE AND OTHER RESULTS UTILITIES AND THE UTILITY COMPANY.
2. THE CONTRACTOR SHALL NOT OBTAIN POWER FROM THE CONTRACTOR SHALL MAINTAIN THE SEPARATION FROM ALL UTILITIES TO THE CONDITION AS IT EXIST. THIS CONTRACTOR SHALL MAINTAIN THE SEPARATION FROM ALL UTILITIES TO THE CONDITION AS IT EXIST.
3. THE CONTRACTOR SHALL MAINTAIN THE SEPARATION FROM ALL UTILITIES TO THE CONDITION AS IT EXIST.
4. THE CONTRACTOR SHALL MAINTAIN THE SEPARATION FROM ALL UTILITIES TO THE CONDITION AS IT EXIST.
5. THE CONTRACTOR SHALL MAINTAIN THE SEPARATION FROM ALL UTILITIES TO THE CONDITION AS IT EXIST.
6. THE CONTRACTOR SHALL MAINTAIN THE SEPARATION FROM ALL UTILITIES TO THE CONDITION AS IT EXIST.
7. THE CONTRACTOR SHALL MAINTAIN THE SEPARATION FROM ALL UTILITIES TO THE CONDITION AS IT EXIST.
8. THE CONTRACTOR SHALL MAINTAIN THE SEPARATION FROM ALL UTILITIES TO THE CONDITION AS IT EXIST.
9. THE CONTRACTOR SHALL MAINTAIN THE SEPARATION FROM ALL UTILITIES TO THE CONDITION AS IT EXIST.
10. THE CONTRACTOR SHALL MAINTAIN THE SEPARATION FROM ALL UTILITIES TO THE CONDITION AS IT EXIST.
11. THE CONTRACTOR SHALL MAINTAIN THE SEPARATION FROM ALL UTILITIES TO THE CONDITION AS IT EXIST.
12. THE CONTRACTOR SHALL MAINTAIN THE SEPARATION FROM ALL UTILITIES TO THE CONDITION AS IT EXIST.
13. THE CONTRACTOR SHALL MAINTAIN THE SEPARATION FROM ALL UTILITIES TO THE CONDITION AS IT EXIST.
14. THE CONTRACTOR SHALL MAINTAIN THE SEPARATION FROM ALL UTILITIES TO THE CONDITION AS IT EXIST.
15. THE CONTRACTOR SHALL MAINTAIN THE SEPARATION FROM ALL UTILITIES TO THE CONDITION AS IT EXIST.
16. THE CONTRACTOR SHALL MAINTAIN THE SEPARATION FROM ALL UTILITIES TO THE CONDITION AS IT EXIST.
17. THE CONTRACTOR SHALL MAINTAIN THE SEPARATION FROM ALL UTILITIES TO THE CONDITION AS IT EXIST.
18. THE CONTRACTOR SHALL MAINTAIN THE SEPARATION FROM ALL UTILITIES TO THE CONDITION AS IT EXIST.
19. THE CONTRACTOR SHALL MAINTAIN THE SEPARATION FROM ALL UTILITIES TO THE CONDITION AS IT EXIST.
20. THE CONTRACTOR SHALL MAINTAIN THE SEPARATION FROM ALL UTILITIES TO THE CONDITION AS IT EXIST.
21. THE CONTRACTOR SHALL MAINTAIN THE SEPARATION FROM ALL UTILITIES TO THE CONDITION AS IT EXIST.
22. THE CONTRACTOR SHALL MAINTAIN THE SEPARATION FROM ALL UTILITIES TO THE CONDITION AS IT EXIST.
23. THE CONTRACTOR SHALL MAINTAIN THE SEPARATION FROM ALL UTILITIES TO THE CONDITION AS IT EXIST.
24. THE CONTRACTOR SHALL MAINTAIN THE SEPARATION FROM ALL UTILITIES TO THE CONDITION AS IT EXIST.
25. THE CONTRACTOR SHALL MAINTAIN THE SEPARATION FROM ALL UTILITIES TO THE CONDITION AS IT EXIST.

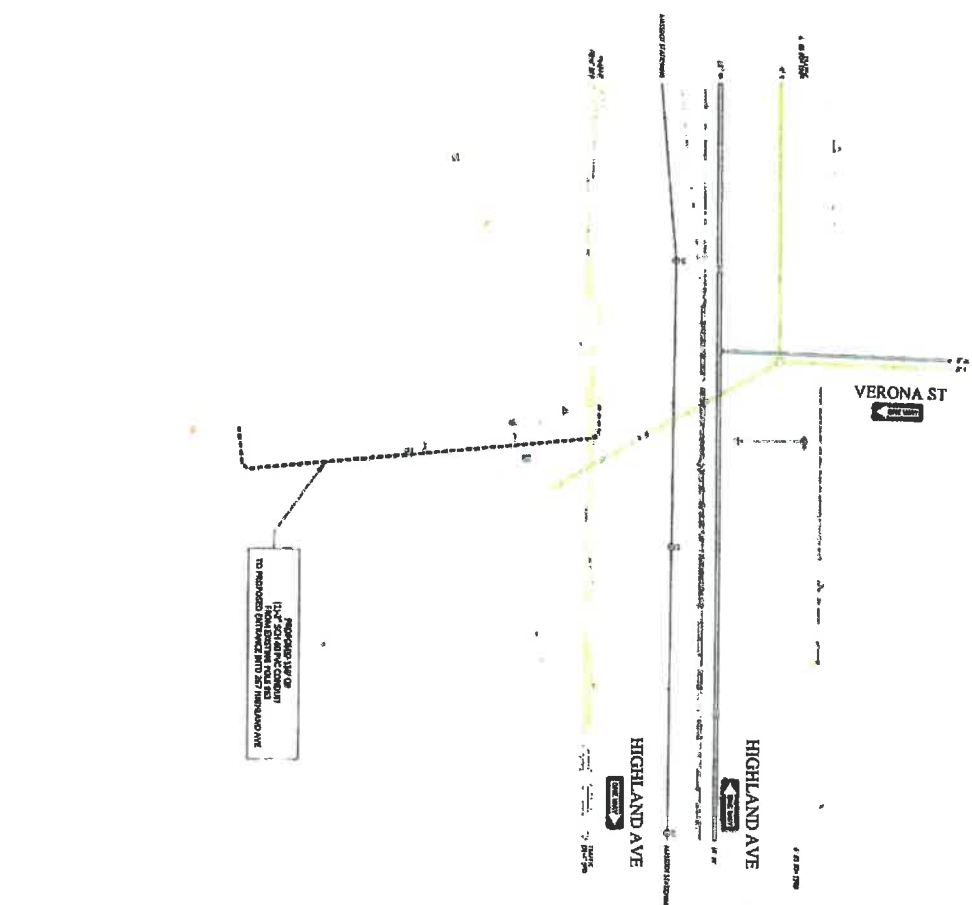
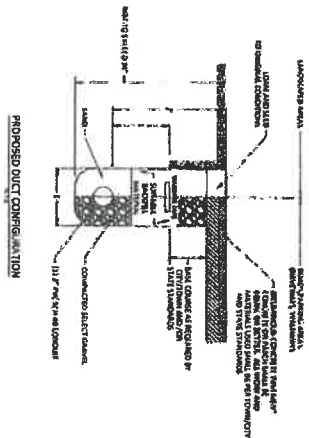

237 HIGHLAND AVE
COMCAST FIBER SAN

Comcast

3100 NORTH 19TH STREET
PHOENIX, AZ 85016

LEGEND

1	SOLID LINE
2	DASHED LINE
3	1/4\"/>



IDENTIFY ALL UTILITIES BEFORE ANY EXCAVATION AND
 CONSTRUCTION SHALL VERIFY THE LOCATION OF ALL
 PUBLIC AND PRIVATE UTILITIES TO BE MAINTAINED
 AND PROTECTED
 CALL BEFORE YOU DIG
 800-4-A-SAFE
 800-4-A-SAFE
 800-4-A-SAFE

USE OF CONSTRUCTION SIGNAGE
 1" = 40 FEET
 0 40 80 120 160

50%
 25%
 10%
 5%
 2%
 1%
 0%
 50%
 25%
 10%
 5%
 2%
 1%
 0%

Comcast
 Comcast
 Comcast

THESE STAMPING
 SELF STAMPING
 (NOT TO SCALE)

NOTE:
 ALL WORKERS MUST BE TRAINED ON SITE
 SAFETY STANDARDS AND BE AUTHORIZED TO ENTER
 THE SITE



ITEM	DESCRIPTION
1	WORK ZONE
2	CONSTRUCTION ZONE SIGN
3	NO PARKING
4	NO STOPPING
5	NO RIGHT TURN
6	NO U-TURN
7	NO LEFT TURN
8	NO THROUGH TRUCKS
9	TRUCK ROUTE ALTERNATIVE
10	TRUCK FLOW
11	TRUCK FLOW
12	TRUCK FLOW
13	TRUCK FLOW
14	TRUCK FLOW
15	TRUCK FLOW
16	TRUCK FLOW
17	TRUCK FLOW
18	TRUCK FLOW
19	TRUCK FLOW
20	TRUCK FLOW
21	TRUCK FLOW
22	TRUCK FLOW
23	TRUCK FLOW
24	TRUCK FLOW
25	TRUCK FLOW
26	TRUCK FLOW
27	TRUCK FLOW
28	TRUCK FLOW
29	TRUCK FLOW
30	TRUCK FLOW
31	TRUCK FLOW
32	TRUCK FLOW
33	TRUCK FLOW
34	TRUCK FLOW
35	TRUCK FLOW
36	TRUCK FLOW
37	TRUCK FLOW
38	TRUCK FLOW
39	TRUCK FLOW
40	TRUCK FLOW
41	TRUCK FLOW
42	TRUCK FLOW
43	TRUCK FLOW
44	TRUCK FLOW
45	TRUCK FLOW
46	TRUCK FLOW
47	TRUCK FLOW
48	TRUCK FLOW
49	TRUCK FLOW
50	TRUCK FLOW

PHASE I



Council President Beth Gerard
Salem City Hall
93 Washington Street
Salem, MA 01970

Dear Councilor Gerard,

Creative Collective respectfully requests the closure of vehicular traffic on the lower end of Essex Street from the Peabody Essex Museum Connect Space to the intersection of Hawthorne Boulevard during the Peabody Essex Museum Block Party. Creative Collective is working collaboratively with the Museum to host a vendor fair during the event taking place on July 21, 2018. The vendor fair is scheduled to take place from 3:00 PM - 10:00 PM and we are requesting a closure from 1:30 - 10:30 PM.

The Peabody Essex Museum Block Party in its second year is a summer celebration geared toward locals and includes an outdoor party featuring live music by The Doped Up Dollies, Big D and the Kids Table, and Bim Skala Bim Music, a beer garden and ice cream from Melt Ice Cream, and food from A&B Burgers. Closing the street allows Creative Collective to host a vendor fair as part of the event without worrying about crowds spilling out into the streets (with good weather we are expecting over 1,000 individuals to attend).

If our proposal is approved, we will work with the Police and Fire departments to implement any security measures that they recommend. We have already proceeded through Licensing to get appropriate licensing for the event.

Thank you for your consideration! If you have any questions or concerns, please contact me at (978) 224-8856 or via email at John@CreativeCollectiveMA.com

Thank you for your time and consideration,

John Andrews
Owner, Creative Collective

*C.C. Chief Mary Butler, Chief John G. Giunta, Councilor Christine Madore,
Dominick Pangallo, and Ilene Simons*
Enclosure: Map of requested closure

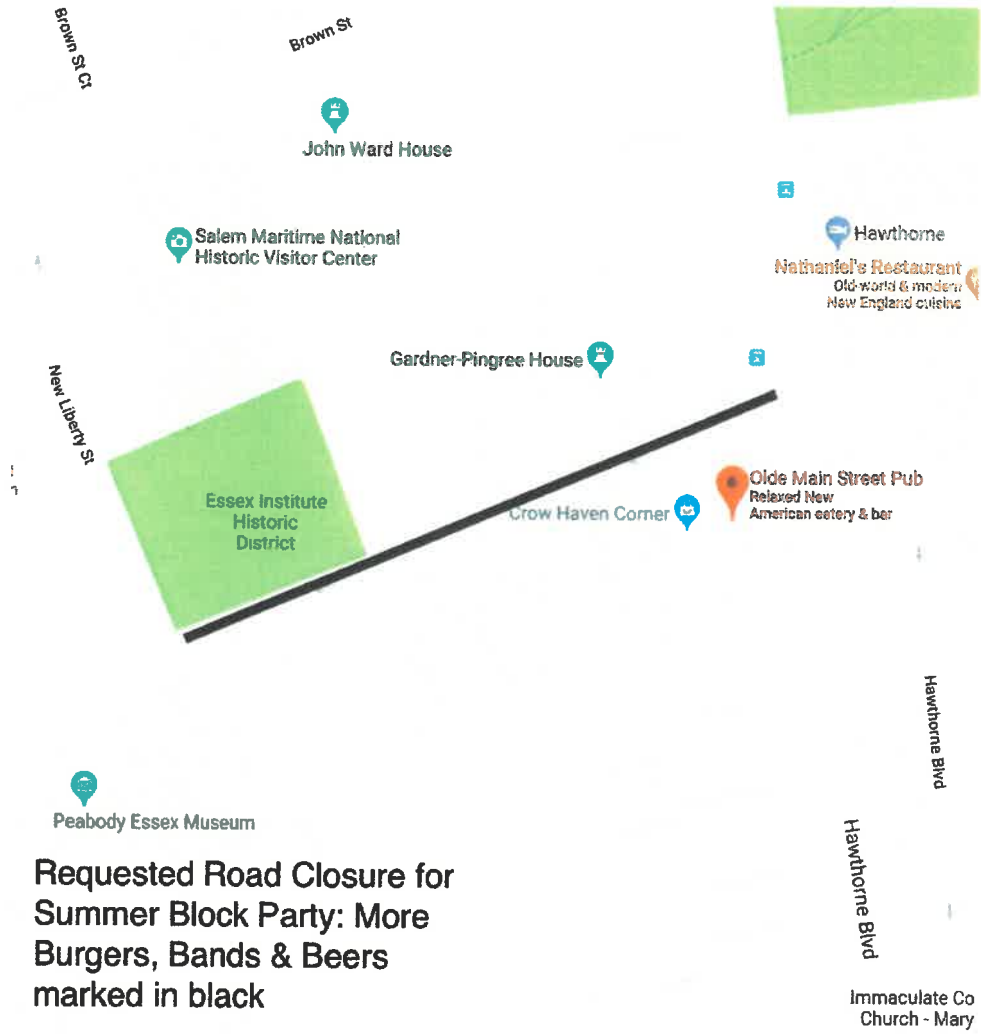

**Requested Road Closure for
Summer Block Party: More
Burgers, Bands & Beers
marked in black**

Ilene Simons

From: John Andrews <john@creativecollectivema.com>
Sent: Monday, June 25, 2018 6:02 PM
To: Beth Gerard; Christine Madore; Mary Butler; Dominick Pangallo; Ilene Simons
Cc: Doneeca Thurston; Robyn Giannopolo
Subject: Request for road closure for Peabody Essex Museum Block Party
Attachments: Street Closure Request.pdf

Hi friends! So we are working with Doneeca on an event at the Peabody Essex Museum on July 21st and will be managing the vendor portion that will happen on the Visitors Center section of Essex Street and Doneeca had already gone to licensing but we did not realize we had to go through the council for the closure. (I work for the city too much haha and this stuff is usually already done by Ellen!)

I will be dropping off a hard copy of this to Ilene in the AM! Doneeca will be out of the country and we have the drive in that night so Christine will be presenting our request.

Thank you so much for your time and consideration.

--

John Andrews
Creative Collective
Creative North Shore

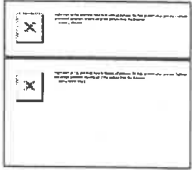

[#jointhecollective](#)
[Sign up for our newsletter](#)

City of Salem

In the year two thousand and eighteen

An Ordinance to amend an Ordinance relative to Zoning

Be it ordained by the City Council of the City of Salem, as follows:

Section 1. Section 3.0 TABLE OF PRINCIPAL AND ACCESSORY USE REGULATIONS of the Zoning Ordinance is hereby amended as follows:

a. Within Section A. Residential Uses of Table, delete the letter “n” as it appears in the B1 Zoning district in the row entitled “Dwelling unit above first floor retail, personal service, or office use” and insert the letter “Y” and an asterisk “*”. And further, insert the following sentence below the table: “*Dwelling unit above first floor retail, personal service, or office use shall only apply to parcels with a lot area less than 20,000 s.f.”

b. Within the Zoning District I of Section C. Commercial Uses of the Table, make the following amendments:

- 1) delete the “N” as it appears in the row entitled “Commercial recreation, outdoor” and insert the letters “BA”
- 2) delete the “N” as it appears in the row entitled “General service establishment” and insert the letter “Y”
- 3) delete the “N” as it appears in the row entitled “Plumbing, carpentry and sheet metal shop” and insert the letter “Y”

c. Within the Zoning District I of Section D. Industrial Uses of the Table, make the following amendments:

- 1) delete the “BA” as it appears in the row entitled “Mini-storage warehouse facility” and insert a “Y”

d. Within the Zoning District I of Section E. Accessory Uses of the Table, make the following amendments:

- 1) delete the “N” as it appears in the row entitled “Private garages and other accessory structures” and insert a “BA”

Section 2. This Ordinance shall take effect as provided by City Charter.

In City Council February 22, 2018

Referred to the Planning Board to schedule a joint public hearing with the City Council

Joint Public Hearing held on April 9, 2018 and advertised in the Salem News on March 26, 2018 and April 2, 2018

Joint Public Hearing remain open and continued to April 30, 2018 at 6:00 P.M.

Continuation of Joint Public Hearing April 30, 2018

Joint Public Hearing Closed

Referred to the Planning Board as amended for their recommendation

In City Council May 24, 2018

Referred to the Committee on Ordinances, Licenses and Legal Affairs co-posted with the Committee of the Whole

In City Council June 14, 2018

Adopted as amended for first passage a motion to insert Section 1. subsection (a) by a roll call vote of 9 yeas, 2 nays, 0 absent

Adopted as amended for first passage a motion to adopt b, c and d by a roll call vote of 11 yeas, 0 nays, 0 absent

ATTEST:

ILENE SIMONS
CITY CLERK

City of Salem

In the year two thousand and eighteen

An Ordinance to amend the Ordinance relative to Zoning

Be it ordained by the City Council of the City of Salem, as follows:

Section 1. Section 3.2.5 Swimming Pools is hereby amended by inserting a new paragraph at the end of this section as follows:

“2. Pools shall be surrounded by a permanent fence or wall at least four (4) feet high measured from the ground above the finished ground level measured on the side of the barrier which faces away from the swimming pool. Fences shall be constructed of pickets, stockade or chain-link type material. Rail Fences shall not be permitted. Any fence gate must have a locking and self-closing device so as to keep the gate shut at all times.”

Section 2. This Ordinance shall take effect as provided by City Charter.

In City Council February 22, 2018

Referred to the Planning Board to schedule a Joint Public Hearing with the City Council
Joint Public Hearing Held on April 9, 2018 and advertised in the Salem News on March 26, 2018 and April 2,
2018

Referred to Planning Board for their recommendation

In City Council May 10, 2018

Referred to the Committee on Ordinances, Licenses and Legal Affairs co-posted with the Committee of the
Whole

In City Council June 14, 2018

Adopt as amended for first passage by roll call vote 11 yeas, 0 nays, 0 absent

ATTEST:

ILENE SIMONS
CITY CLERK

City of Salem

In the year two thousand and eighteen

An Ordinance to amend the Ordinance relative to Zoning

Be it ordained by the City Council of the City of Salem, as follows:

Section 1. Section 4.1.1 Table of Dimensional Requirements is hereby amended by adding the following new row to the table:

Table of Dimensional Requirements										
	RC	R1	R2*	R3**	B1****	B2	B4	I	BPD	NRCC
Maximum height of retaining walls, boundary walls and/or fences (feet)***	6	6	6	6	10	10	10	10	10	4

Section 2. Section 4.1.1 Table of Dimensional Requirements is hereby amended by adding the following new sentence to the end of asterisk *** notation:

“Fences shall be no more than six (6) feet for residential uses, excluding the NRCC district unless otherwise provided, and ten (10) feet for commercial uses.”

Section 3. Section 4.1.1 Table of Dimensional Requirements is hereby amended by inserting “3,500” in the B1 column of the row entitled “Minimum lot area per dwelling unit (square feet).”

Section 4. This Ordinance shall take effect as provided by City Charter.

In City Council February 22, 2018

Referred to the Planning Board to schedule a Joint Public Hearing with the City Council

Joint Public Hearing Held on April 9, 2018 and advertised in the Salem News on March 26, 2018 and April 2, 2018

Joint Public Hearing to remain open and continue on April 30, 2018 at 6:00 P.M.

April 30, 2018 Continuation of the Joint Public Hearing

Joint Public Hearing Closed

Referred to Planning Board as amended for their recommendation

In City Council May 24, 2018

Referred to the Committee on Ordinances, Licenses and Legal Affairs co-posted with the Committee of the Whole

In City Council June 14, 2018

Adopted for first passage by roll call vote 11 yeas, 0 nays, 0 absent

ATTEST:

ILENE SIMONS
CITY CLERK

City of Salem

In the year two thousand and eighteen

An Ordinance to amend an Ordinance relative to Zoning

Be it ordained by the City Council of the City of Salem, as follows:

Section 1. Section 10.0 DEFINITIONS of the Salem Zoning Ordinance is hereby amended by:

a. Inserting the following at the end of the definition of “Dwelling Unit”:

“as defined by the Commonwealth of Massachusetts State Building Code Regulations & Standards 780 CMR

b. Deleting the definition of “Rooming, boarding or lodging house” in its entirety and replacing it with the following:

“Rooming, boarding or lodging house: A house where lodgings are let to four (4) or more persons not within second degree of kindred to the person conducting it, and shall include fraternity houses and dormitories of educational institutions, but shall not include dormitories of charitable or philanthropic institutions or convalescent or nursing homes licensed under section seventy-one of chapter one hundred eleven or rest homes so licensed, or group residences licensed or regulated by agencies of the Commonwealth.”

c. Amending the definition of “General service establishment” by inserting the word “and” immediately before the word “furniture” and deleting the phrase “and the like.”

d. Inserting three new definitions as follows:

“Assisted Living Residences: Offer a combination of housing, meals and personal service care to adults for a fee that includes room and board and services. Assisted living residences are intended for adults who may need some help with activities such as housekeeping, meals, bathing, dressing, and/or medication assistance and who like the security of having assistance available on a 24 hour basis in a home-like and non-institutional environment. Assisted living residences do not provide medical or nursing services and are not designed for people who need serious medical care on an ongoing basis.”

“Site Plan Review: Site plan review is a review process established by the City to protect and promote health, safety, convenience and general welfare of the residents of Salem. Site plan review establishes criteria for the layout, scale, appearance, safety, and environmental impacts of development. Site plan review focuses on parking, traffic, drainage, utilities,

landscaping, lighting and other aspects of the proposal to arrive at the best possible design for the location.”

“Zoning Board of Appeals: The Zoning Board of Appeals as established by Chapter 40A, Section 12 of the Massachusetts General Laws.”

Section 2. This Ordinance shall be adopted as provided in the City Charter.

In City Council February 22, 2018

Referred to the Planning Board to schedule a joint public hearing with the City Council

Joint Public hearing held on April 9, 2018 and advertised in the Salem News on March 26, 2018 and April 2, 2018

Joint Public Hearing remained open and continue to April 30, 2018 at 6:00 P.M.

April 30, 2018 Continuation of Joint Public Hearing

Joint Public Hearing Closed

Referred to the Planning Board as amended for their recommendations

Amendments include: Section 1 (a) amending the definition of “Dwelling Unit”: keep “as defined by the Commonwealth of Massachusetts State Building Code Regulations & Standards 780 CMR.” And deleting the remainder of the definition; 1 (b) Amending the definition of “Rooming, boarding or lodging house: by correcting the spelling on the first line from were to where; deleting on the third line after the words “but shall not include” delete “fraternity houses and” and adding on the fifth line after the words “licensed under section” add “seventy-one of chapter one hundred eleven; 1 (d) “Assisted Living Residences:” by correcting the word “design” to “designed” on the second to last sentence of paragraph

In City Council May 24, 2018

Referred to the Committee on Ordinances, Licenses and Legal Affairs co-posted with the Committee of the Whole

In City Council June 14, 2018

Adopted for first passage by unanimous roll call vote of 11 yeas, 0 nays, 0 absent

ATTEST:

ILENE SIMONS
CITY CLERK

City of Salem

In the year Two Thousand and Eighteen

An Ordinance to amend an Ordinance relative to zoning

Be it ordained by the City Council of the City of Salem, as follows:

Section I. Sub-paragraph 4(a) of Section 8.4.9 Parking Requirements is hereby amended by deleting 4(a) in its entirety and replacing it with the following:

“a. One and a half (1.5) parking spaces per dwelling unit.”

Section II. This Ordinance shall take effect as provided by City Charter.

In City Council February 22, 2018

Referred to the planning Board to schedule a joint public hearing with the City Council

Joint Public Hearing held on April 9, 2018 and advertised in the Salem News on March 26, 2018 and April 2, 2018

Joint Public Hearing Closed and referred to the Planning Board for their recommendation

In City Council May 10, 2018

Referred to the Committee on Ordinances, Licenses and Legal Affairs co-posted with the Committee of the Whole

In City Council June 14, 2018

Adopted for first passage by roll call vote of 9 yeas, 2 nays, 0 absent

ATTEST:

CHERYL A. LAPOINTE
CITY CLERK

City of Salem

In the year Two Thousand and Eighteen

An Ordinance to amend an Ordinance relative to Rates for Use of Water

Be it ordained by the City Council of the City of Salem, as follows:

Section 1.

Chapter 46, Section 66 is hereby amended by deleting subparagraph (b) in its entirety and replacing it with the following:

“(b) The rate for all water furnished by meter measurements effective July 1, 2018 shall be as follows:

(1) Residential, per 100 cubic feet \$3.31

(2) Nonresidential, per 100 cubic feet \$4.48

Section 2. Chapter 46, Section 66 is hereby further amended by deleting subparagraph (e) in its entirety and replacing it with the following:

“(e) The minimum rate for residential metered water for each quarter shall be \$33.10 per 1000 cubic feet effective July 1, 2018.

The use of all water and sewer funds and SESD funds shall be excluded from all private development projects.”

Section 3. This Ordinance shall take effect as provided by City Charter.

In City Council May 24, 2018

Referred to the Committee on Administration and Finance coposted with the Committee of the Whole

In City Council June 14, 2018

Adopted for first passage

ATTEST:

ILENE SIMONS
CITY CLERK

City of Salem

In the year Two Thousand and eighteen

An Ordinance to amend an Ordinance relative to Sewer Use Charges

Be it ordained by the City Council of the City of Salem, as follows:

Section 1. Chapter 46, Section 230 is hereby amended by deleting subsection (c) in its entirety and replacing it with the following:

“(c) The rates for sewer use charges effective July 1, 2018 shall be as follows:

Residential, per 100 cubic feet...	\$6.71
Nonresidential, per 100 cubic feet up to 25,000 cubic feet per month	\$10.61
Nonresidential, per 100 cubic feet for 25,000 cubic feet and greater per month	\$13.01

The use of all water and sewer funds and SESD funds shall be excluded from all private development projects.”

Section II. This Ordinance shall take effect as provided by City Charter.

In City Council May 24, 2018

Referred to the Committee on Administration and Finance coposted with the Committee of the Whole

In City Council June 14, 2018

Adopted for first passage

ATTEST:

ILENE SIMONS
CITY CLERK

City of Salem

In the year two thousand and eighteen

An Ordinance to amend an Ordinance relative to the City Marshal

Be it ordained by the City Council of the City of Salem, as follows:

Section 1. Chapter 32, Police, Article II, Section 32-47- *Chief of department; control and discipline of department.* is hereby deleted and replaced with the following:

“Section 32-47- Chief of department; control and discipline of department.

The city marshal shall be the chief of the police department and, subject to the approval of the mayor, shall have entire control of the police department and all its officers and other officers when engaged in the services of the city or when assigned to any special duty. The city marshal shall be responsible for the discipline and efficiency of the police department. The city marshal shall also have control over the constables appointed by the Mayor pursuant to Sec. 32-19. Nothing in this section shall be construed to change the official title of city marshal as head of the police department.

Section 2. Chapter 32, Police, Article II, Sec. 32-48. *Vacancy in office* is hereby deleted and replaced with the following:

“Sec. 32-48. Vacancy in office.

Absent the establishment of a permanent deputy chief position within the Salem Police Department, if a vacancy occurs in the office of city marshal, the mayor shall designate from among those serving in the rank of captain, or from among those serving in the rank of lieutenant and captain, if there are less than three captains, an officer to serve as the acting city marshal and have all the powers and shall perform all the duties of the city marshal until such time as a new city marshal is duly appointed.”

Section 3.

These ordinance amendments shall take effect as provided by City Charter.

In City Council May 24, 2018

Referred to the Committee on Ordinances, Licenses and Legal Affairs co-posted with Committee of the Whole

In City Council June 14, 2018

Adopted for first passage by roll call vote of 11 yeas, 0 nays, 0 absent

ATTEST:

ILENE SIMONS
CITY CLERK

CITY OF SALEM

In City Council, May 24, 2018

Fiscal Year 2019 General Fund Capital Improvement Program

Ordered:

That the sum of \$10,696,190.00 be and hereby is appropriated to pay costs of the following capital equipment and capital improvement projects listed under the heading FY19 CIP- Funded from BOND AUTHORIZATION and for the payment of all costs incidental and related thereto, and that to meet said appropriation the Treasurer, with the approval of the Mayor, is authorized to borrow said sum under M.G.L. Chapter 44, Section 7, or pursuant to any other enabling authority, and to issue bonds or notes of the City therefor.

FY19 CIP-Funded from BOND AUTHORIZATION

Electrical	Bridge Street LED Conversion	\$ 104,473
Electrical	LED Lighting Upgrades (100 watt LED Lum.)	\$ 34,833
Electrical	Smart Signalization Expansion	\$ 75,000
Engineering	Boston Street Corridor Roadway Improvements	\$ 200,000
Engineering	Bridge Street (Massworks) Roadway Improvements	\$ 150,000
Engineering	Canal Street Bike Path	\$ 500,000
Engineering	Canal Street Corridor Roadway Improvements	\$ 250,000
Engineering	Citywide Seawall Improvements	\$ 50,000
Engineering	Essex St Ped and Vehicle Access Improvements	\$ 1,500,000
Engineering	First/Swampscott Rd Intersection Improvement & Design	\$ 750,000
Engineering	Forest River Park and Pool Design/Improvements	\$ 100,000
Engineering	Forest River Park Seawall Replacement	\$ 2,250,000
Engineering	Loring and Lafayette Improvements	\$ 100,000
Engineering	Roads, Sidewalks & Crosswalks (Non Chapter 90 eligible)	\$ 500,000
Information Technology	Annual Equipment-Life-Cycle Management Program (City)	\$ 136,943
Information Technology	Annual Equipment- Life-Cycle Management Program (Schools)	\$ 220,161
Information Technology	Ongoing Digitization of record, City wide	\$ 125,000
Information Technology	Telephone System Replacement-City/Schools	\$ 511,111
Library	HVAC Design, Engineering & Construction (370 Essex St.)	\$ 370,000
Parks, Recreation & Community Services	Bertram Field Schematic Design Phase II	\$ 75,000
Parks, Recreation & Community Services	Court Renovations	\$ 125,000
Parks, Recreation & Community Services	Golf Course Cart Paths	\$ 440,000
Parking and Traffic Depart.	Museum Place Garage Security Camera System	\$ 210,000
Parking and Traffic Depart.	South Harbor Garage Restoration	\$ 40,000
Parking and Traffic Depart.	Church Street Parking reconfiguration	\$ 413,669
Parking and Traffic Depart.	Bicycle Infrastructure Upgrades	\$ 25,000
Parking and Traffic Depart.	Parking Kiosk Installation	\$ 25,000
Parking and Traffic Depart.	Signs / Safety / Tactical	\$ 25,000
Parking and Traffic Depart.	Traffic Calming Improvements	\$ 75,000
Planning	Charter Street Cemetery	\$ 75,000
Planning	Common Fence	\$ 125,000
Planning	Collins Cove Living Shoreline	\$ 50,000
Planning	Second Ferry Acquisition	\$ 600,000
Planning	South River Float and Tie Up, Derby Dinghy	\$ 200,000
Schools	Build out-Vocational Shop	\$ 45,000
Schools	College & Career Center floor (High School)	\$ 70,000

Schools	Playground upgrade/replacement	\$ 40,000
Schools	Salerno Roof & Mechanical HVAC replacement	\$ 110,000
	TOTAL BOND AUTHORIZATION:	\$ 10,696,190

Any premium received upon the sale of any bonds or notes approved by this vote, less any such premium applied to the payment of the costs of issuance of such bonds or notes, may be applied to the payment of costs approved by this vote in accordance with Chapter 44, Section 20 of the General Laws, thereby reducing the amount authorized to be borrowed to pay such costs by a like amount.

Be it further Ordered:

That the Mayor and the Treasurer are each authorized to file an application to qualify under Chapter 44A of the Massachusetts General Laws any and all bonds of the City issued under and pursuant hereto, and to provide such information and execute such documents as may be required in connection therewith.

In City Council May 24, 2018

Received after the deadline of Tuesday Noon under suspension of the rules

Referred to the Committee on Administration and Finance co-posted with the Committee of the Whole

In City Council June 14, 2018

A motion was made to reduce the total bond order amount by \$1.3 Million

Did Not Pass by Roll Call Vote of 3 yeas, 8 nays, 0 absent

Adopted for first passage by Roll Call Vote of 11 yeas, 0 nays, 0 absent

ATTEST:

ILENE SIMONS
CITY CLERK

CITY OF SALEM

In City Council, May 24, 2018

Fiscal Year 2019 Enterprise Fund Capital Improvement Program

Loan Order:

That the sum of \$13,300,000.00 be and hereby is appropriated to pay costs of the following capital equipment and capital improvement projects listed under the heading FY19 CIP- Funded from BOND AUTHORIZATION and for the payment of all costs incidental and related thereto, and that to meet said appropriation the Treasurer, with the approval of the Mayor, is authorized to borrow said sum under M.G.L. Chapter 44, Sections 7 and/or 8, or pursuant to any other enabling authority, and to issue bonds or notes of the City therefor.

FY19 CIP-Funded from \BOND AUTHORIZATION		
Water	Highland Ave 16 inch Water Main and Valves	\$ 100,000
Water	Szetela Lane (from Lee Fort Terrace to memorial drive loop)	\$ 250,000
Water	Citywide Flushing, Valve Leak detection, GIS	\$ 250,000
Water	City Wide Water System Flushing, Valve Maintenance, Leak Detection and GIS Administration	\$ 400,000
Sewer	City Wide Sewer System Flushing, Valve Maintenance, Leak Detection and GIS Administration	\$ 200,000
Sewer	EPA MS4 Storm Water Permit Compliance/Illicit Connection Removal	\$ 250,000
Sewer	Pre-Paving Sewer/ drain inspections (prior to annual paving)	\$ 50,000
Sewer	SSES report implementation (eliminate I/I sources city wide)	\$ 150,000
Sewer	289 Derby Drain (replace existing)	\$ 350,000
Sewer	Fowler and No Pine St Sewer Rehabilitation	\$ 400,000
Sewer	Moffat drainage easement improvements	\$ 50,000
Sewer	Willow Ave (pipe beach) sewer replacement	\$ 100,000
Sewer	Canal Street- SSU Flood Mitigation Improvements-Phase II	\$ 10,000,000
Sewer	Rosie's Pond flood improvements	\$ 750,000
	TOTAL BOND AUTHORIZATION:	\$ 13,300,000

Any premium received upon the sale of any bonds or notes approved by this vote, less any such premium applied to the payment of the costs of issuance of such bonds or notes, may be applied to the payment of costs approved by this vote in accordance with Chapter 44, Section 20 of the General Laws, thereby reducing the amount authorized to be borrowed to pay such costs by a like amount.
Be it further Ordered:

That the Mayor and the Treasurer are each authorized to file an application to qualify under Chapter 44A of the Massachusetts General Laws any and all bonds of the City issued under and pursuant hereto, and to provide such information and execute such documents as may be required in connection therewith.

In City Council May 24, 2018

Received after the deadline of Tuesday Noon under suspension of the rules

Referred to the Committee on Administration and Finance co-posted with the Committee of the Whole

In City Council June 14, 2018

Adopted for first passage by roll call vote of 11 yeas, 0 nays, 0 absent

ATTEST:

ILENE SIMONS
CITY CLERK