

ORDERED:

Notice having been given and public hearing held, as provided by law, that the NATIONAL GRID be and it is hereby granted permission to excavate the public highways and to run and maintain underground electric conduits, together with such sustaining and protecting fixtures as said company may deem necessary, in the public way or ways hereinafter referred to, and to make the necessary house connections along said extensions, as requested in petition with said company dated the 20th day of June 2019.

Said underground electric conduits shall be located substantially in accordance with the plan filed herewith marked – Briggs St - Salem - Massachusetts. Plan # 28427829.

The following are the public ways or part of ways along which the underground electric conduits above referred to may be laid:

Briggs St - National Grid to install beginning at a point approximately 320 feet northeast of the centerline of the intersection of Briggs St and continuing approximately 100 feet in a northwest direction. Customer to trench Briggs St approximately 100' from pole 3003 to proposed pad-mounted transformer inside the customer's property.

I hereby certify that the foregoing order was adopted at a meeting of the
.....
....., held on the day of, 20
....., 20

Received and entered in the records of location orders of the City/Town of
Book Page

Attest:
.....

..... hereby certify that on20....., at o'clock,M
at, a public hearing was held on the petition of
NATIONAL GRID for permission to construct the underground electric conduits described in the
order herewith recorded, and that I mailed at least seven days before said hearing a written notice
of the time and place of said hearing to each of the owners of real estate (as determined by the last
preceding assessment for taxation) along the ways or parts of ways upon which the Company is
permitted to construct the underground electric conduits under said order. And that thereupon said
order was duly adopted.

.....
.....

Ilene Simons

From: Deborah Duhamel
Sent: Tuesday, June 25, 2019 1:54 PM
To: Ilene Simons; John Giardi; David Knowlton
Subject: RE: Conduit on ~~Beaver St.~~ *Briggs St.*

Hi Ilene,

Engineering is okay with this conduit on Briggs.

Thanks,
Deb

From: Ilene Simons
Sent: Tuesday, June 25, 2019 9:48 AM
To: John Giardi <JGiardi@Salem.com>; David Knowlton <DKnowlton@Salem.com>; Deborah Duhamel <dduhamel@Salem.com>
Subject: Conduit on Beaver St.

Hearing will be held on July 18th. Feedback before then will be appreciated

Thank you,

Ilene Simons
City Clerk
Justice of the Peace
93 Washington Street
Salem, MA 01970
(978) 745-9595 ext. 41201

Ilene Simons

From: John Giardi
Sent: Tuesday, June 25, 2019 1:15 PM
To: Ilene Simons *Briggs St.*
Subject: RE: Conduit on ~~Beaver St.~~

Good afternoon Ilene, I thought that was the case, Thank you and Electrical is all set with Briggs Street. City Electrician, John Giardi

From: Ilene Simons
Sent: Tuesday, June 25, 2019 11:23 AM
To: John Giardi
Subject: RE: Conduit on Beaver St.

Hi John:

I actually meant Briggs St. Sorry for the confusion.

Ilene Simons
City Clerk
Justice of the Peace
93 Washington Street
Salem, MA 01970
(978) 745-9595 ext. 41201

From: John Giardi <JGiardi@Salem.com>
Sent: Tuesday, June 25, 2019 9:58 AM
To: Ilene Simons <ISimons@Salem.com>
Subject: RE: Conduit on Beaver St.

Good morning Ilene the drawing does not reflect Beaver Street. Maybe the wrong one got scanned. Please advise. Thank you Ilene, John

From: Ilene Simons
Sent: Tuesday, June 25, 2019 9:48 AM
To: John Giardi; David Knowlton; Deborah Duhamel
Subject: Conduit on Beaver St.

Hearing will be held on July 18th. Feedback before then will be appreciated

Thank you,

Ilene Simons
City Clerk
Justice of the Peace
93 Washington Street
Salem, MA 01970
(978) 745-9595 ext. 41201



CITY OF SALEM, MASSACHUSETTS

Kimberley Driscoll
Mayor

Office of the Mayor

June 27, 2019

Salem City Council
City Hall
93 Washington Street
Salem, MA 01970

Ladies and Gentlemen of the City Council:

I am very pleased to appoint Maureen McKinnon of 93 Canal Street #1 to serve as a member of the Salem Commission on Disabilities. Ms. McKinnon will be commencing a new three-year term to expire June 27, 2022 and will be taking the seat previously held by David Martel.

Ms. McKinnon has worked for many years as an advocate and leader in the disabled community. She is currently a motivational speaker and serves on the Advisory Board for Adaptive Sports New England and for Sail Salem. She has previously served on the boards of the Boston Chapter of the National Spinal Cord Injury Association, U.S. Sailing's National Governing Association, and the City of Boston's Disability Task Force. Her career includes work for Courageous Sailing and the Piers Park Sailing Center. In 2008, Ms. McKinnon earned a gold medal at the 2008 Beijing Paralympic Games on the U.S. sailing team and the following year was nominated for an ESPY Award and received the National Women's Sailing Association's Leadership Award.

I believe Ms. McKinnon will bring an important voice and perspective to the work of the Commission on Disabilities. We are fortunate that she is willing to serve our community in this capacity and I strongly recommend confirmation of her appointment.

Very truly yours,

Kimberley Driscoll
Mayor
City of Salem

Maureen McKinnon

93 Canal St. #1, Salem, MA 01970, MA
mcktucker@gmail.com
781-632-6363

Professional Profile:

Resourceful, energetic, goal-driven program director of nonprofit programs. Six years programming and funding experience for youth sailing organizations. Serves in an advisory capacity on a volunteer basis for many nonprofits serving the needs of the disabled community. Holds broad direct knowledge and achievement working and advocating for the disabled community in many roles. Familiar with the needs of underserved communities.

Professional Experience:

Courageous Sailing, Director of Development and Community Outreach **April 2012- March 2013**

- *Responsible for expanding the growth and diversification of overall funding efforts for a non-profit sailing center serving the underserved youth of Boston.*
- *Created a comprehensive 2013 development plan from a variety of sources, both old and new to increase funding by \$176K. The combined total of the plan was \$430K with outstanding new grants added of \$256K.*
- *Worked with board members, sailing members, staff and community to help promote the center to generate new funding relationships to expand current donor base.*

Piers Park Sailing Center, Adaptive Director, Public Relations **March 2007- March 2012**

- *Began, designed, promoted, built, and recruited for a nationally recognized sailing program for disabled youth and adults.*
- *Twice winner of national Best Program Award and designated as "Paralympic Sport Club".*
- *Teamed with Executive Director to successfully secure \$100-125K of funding each year for our youth program and disabled adults.*
- *Worked with funders and sources such as: grants, foundations, disabled organizations, state and local agencies, individual and corporate donors, media and personal contacts.*

Motivational Keynote Speaker, various locations regionally and nationally. **2007-present**

Paralympic Sailing Campaigns, Athens, Beijing, London & Rio, Sole Fundraiser **May 2002- December 2016**

Secured media, organized fundraisers, letter writing campaigns, wrote blogs, engaged individual donors & corporate donors, grew and maintained list of 1000 supporters, secured funding through awards, achievements and speaking engagements, Social Media promotion, attained In-kind sponsorships and corporate sponsorships.

Boston Chapter of National Spinal Cord Injury Association, Interim Co-Director **2003**

Project C.H.I.L.L.D., Occupational Therapy clinic for autistic & impaired Children, Coordinator **2001-2003**

Back Bay Blossoms, small flower shop, Owner, Manager, Designer & Buyer **August 1989 - January 1997**

Volunteer Affiliations and Experience:

US SAILING, National Governing Association, **Board of Directors**, serving 2nd elected 3 year term **2010-2016**
Advisory Board to Sail Salem, Advisory Committee **2008-present**

Piers Park Sailing Ctr, Board Member **2014- present**
Boston Chapter of the National Spinal Cord Injury Association, **Board Member** **1997-2016**
US SAILING, National Committee, Sailors with Disabilities, **Councilmember** **2008-2017**
Member, Boston Disability Task Force **2011-2016**
Advisory Board of ARB, Access Recreation Boston **2011-2016**
Advisory Board of Adaptive Sports New England **2012-present**

Founder and Member, Marblehead Disability Commission & S.A.C.O.D.	2001-2011
Spaulding Rehab, Volunteer Peer Visitor , mentoring newly paralyzed paraplegics	2001-present
Gimpy Girls Brunch Club, Founder of networking group for women with disabilities	2002-present
Marblehead Festival of Arts, Board Member , Director of Logo Store, Volunteer Coordinator	2002-04, 2013-14

Educational Background:

UMASS Boston, Northeastern University, Boston, MA. Pursued Nursing and Sociology Degrees, 1983-1989
 American Floral Arts School, Chicago, IL, completed certificate, 1987
 Minnechaug Regional H.S., completed college prep, 1983

Awards and Achievements:

Gold Medalist, Beijing Paralympic Games 2008, USA SKUD 18 Crewing for Nick Scandone, Skipper
 Fifth Place, Rio de Janeiro Paralympic Games 2016, USA Skud 18 Team, Crewing for Ryan Porteous
 Nominee for the 2008 Rolex Yachtswoman of the Year Award (shortlisted)
 Nominee for 2009 E.S.P.Y. Awards for disabled athlete category. Los Angeles
 Recipient of the 2009 Paul C Hearne National Leadership Award, AAPD providing a \$10, 000 award to host race clinics for the disabled.
 Recipient of the Women in Sailing Leadership Award, National Women's Sailing Association, 2009
 Two time "Most Outstanding Disabled Sailing Program Award", Adaptive Program, Piers Park Sailing Center, 2009 & 2010

Recommendation:

"Maureen is a true professional who always brings a sunny personality and great personal strength. I've known Maureen for a couple of years and continue to be impressed by her—on many levels. She is a great public speaker who can tell a powerful story. She has a unique ability to connect with an audience in a very personal way. I've seen her hold a crowd and inspire them to action. She is great at building personal relationships and is absolutely fearless. To use one example, we visited Mayor Menino together and she was immediately able to build a strong relationship that has been immensely helpful to Courageous. I have no doubt that in the right role, Maureen will continue to be a star. "

Chip Terry
 Board President
Courageous Sailing

References:

Available upon request



CITY OF SALEM, MASSACHUSETTS

Kimberley Driscoll
Mayor

Office of the Mayor

June 27, 2019

Salem City Council
City Hall
93 Washington Street
Salem, MA 01970

Ladies and Gentlemen of the City Council:

I am very pleased to appoint Malissa Vieira of 41 ½ Harbor Street #3 to serve as a member of the Salem Conservation Commission. Ms. Vieira will be completing the remainder of an unexpired three-year term to conclude November 15, 2021. The seat had been previously held by Gail Kubik.

Ms. Vieira holds a Bachelor's degree in Environmental Biology from UMass-Dartmouth and is passionate about improving the health and integrity of our community's natural ecosystems and habitats. While her current work is in the field of marketing, she has a deep base of knowledge around ecology and conservation sciences.

I believe Ms. Vieira will be a welcome addition to the work of the Conservation Commission. We are fortunate that she is willing to serve our community in this capacity and I strongly recommend confirmation of her appointment.

Very truly yours,

Kimberley Driscoll
Mayor
City of Salem

Malissa L Vieira | malissa.l.vieira@gmail.com

617-229-9759 | 41 1/2 Harbor St, Salem MA 01970

Summary

I am a self-starter and naturally inquisitive worker. I enjoy a work environment that allows me to utilize my skills to meet milestones and deliver. I am passionate about using data to deliver results. I am a lifelong supporter of environmental advocacy and conservation efforts, and some of my volunteer experience includes estuarine water purity testing, beach and urban cleanups, and promoting zero-waste living.

Work History

Digital Marketing & Reporting Coordinator at Scenic Luxury Cruises & Tours
June 2017 to present - 2 years 1 month

- Own email marketing process for Scenic River Cruises, Scenic Eclipse, and Emerald Waterways start to finish: work with brand managers to plan campaigns using Smart Sheet, code emails using HTML5, create design assets (hero images and supplementary design elements) using Adobe Creative Suite, test rendering using Litmus, schedule, deploy, and report metrics within an Email Marketing Program (IBM Silverpop).
- Use email best-practices to optimize email campaigns using mobile-responsive design and A/B subject line and content testing.
- Update CRM records, import data files, maintain file fidelity, and perform regular database cleansing.
- Organize weekly meetings with marketing and design teams to discuss upcoming email marketing initiatives and tactics.
- Report to VP of marketing on email marketing trends and send weekly performance metrics of campaigns.
- Generate and deliver customer segment lists for direct mail marketing.
- Provide assets to third-party vendors for supplemental marketing efforts.
- Perform required edits in CMS as needed.

Digital Marketing Strategist at Ready4

Jan 2017 to June 2017 - 6 months (Boston office closure)

- Code and design HTML email templates for proprietary and partner-based communications to a user base of over 1M native app users
- Design and deploy all in-app messaging and push notification
- Track and nurture lead-generation, and use best practices for organic user base growth, such as A/B testing and calls-to-action
- Use software (AppBoy) to promote proprietary services, such as tutoring and admissions consulting
- Assist in B-to-B servicing through strategic partnerships with prestigious universities across the US
- Create weekly statistical reports to track user engagement



CITY OF SALEM, MASSACHUSETTS

Kimberley Driscoll
Mayor

Office of the Mayor

June 27, 2019

Salem City Council
City Hall
93 Washington Street
Salem, MA 01970

Ladies and Gentlemen of the City Council:

I am very pleased to appoint Paul Viccica of 35 Broad Street to serve as a member of the Salem Zoning Board of Appeals. Mr. Viccica will be completing the remainder of an unexpired three-year term to conclude on May 1, 2022. The seat had previously been held by Patrick Shea. Pending City Council confirmation of his appointment, Mr. Viccica would step down from his current seat as an alternate on the Zoning Board of Appeals to take this regular member seat.

Mr. Viccica is a principal at CBT Architects, where he has worked for the last 22 years. Today he leads the firm's academic group, designing and managing projects for universities, colleges, independent schools, and public institutions including Northeastern University, Harvard Business School, Middlebury College, and Smith College. Many of his projects involve the preservation or repurposing of historic and architecturally significant buildings. In addition to his four years as an alternate on the ZBA, Mr. Viccica also serves on the Advisory Council of the House of the Seven Gables. Mr. Viccica holds a Bachelor's degree from the University of Miami and a Master's degree in architecture from the University of Virginia.

I believe Mr. Viccica has demonstrated thoughtfulness and a familiarity with the issues that are before the ZBA. We are fortunate he is willing to continue to serve our community in this capacity and I recommend confirmation of his appointment to a regular seat on the board.

Very truly yours,

Kimberley Driscoll
Mayor
City of Salem



CITY OF SALEM, MASSACHUSETTS

Kimberley Driscoll
Mayor

Office of the Mayor

July 18, 2019

Salem City Council
City Hall
93 Washington Street
Salem, MA 01970

Ladies and Gentlemen of the City Council:

I am very pleased to appoint Paul L'Heureux of 24 Lafayette Place to serve as a regular member of the Salem Tree Commission. Mr. L'Heureux is appointed to a three-year term to expire July 18, 2022. This seat, specified in Section 43-12(a)(2) is vacant as this Commission is newly established.

Mr. L'Heureux served as the Director of Facilities for the Salem Public Schools for many years and, in that position, had stewardship and responsibility for maintaining and protecting the many trees and open spaces that adjoin our school buildings. He was a member of the Salem Redevelopment Authority for eight years and a member of the LORAX task force, which drafted the tree Ordinance. I believe will contribute positively to the new Tree Commission and its work.

We are fortunate Mr. L'Heureux is willing to serve Salem in this capacity and lend his deep familiarity with our community to the Commission's efforts. I strongly recommend confirmation of his appointment.

Very truly yours,

Kimberley Driscoll
Mayor
City of Salem

RESUME

OF

PAUL P. L'HEUREUX
24 Lafayette Place
Salem, MA 01970
508-744-7264

VITAL STATISTICS

Date of Birth: February 3, 1947
Marital Status: Married, 2 children
Social Security: 018-34-4819

Health: Excellent
Non-smoker, non-drinker

EDUCATION

Graduate of St. Joseph High School, Salem, MA - 1965
Northeast Institute Industrial Technology - Industrial Electronics - 1 year
Graduate - I.B.E.W. Apprenticeship Training Course - 4 years 1972

VETERAN

U.S. Marine Corps, Vietnam Veteran 1966-1968, Honorable Discharge

OCCUPATION

Master Electrician, Commonwealth of Mass. License #A9886
Journeyman Electrician, Commonwealth of Mass. License #E19824
Master Electrician, State of New Hampshire License #7283
Journeyman Electrician, State of New Hampshire License #5200
Master Electrician, State of Maine License #8789
Journeyman Electrician, State of Maine License #2689
Safety Supervisor - New England Electric Systems
President I.B.E.W. Local Union 259 Salem, MA, 9 years
Joint Apprenticeship Training Committee, 9 years
Member - Board of Trustees, I.B.E.W. Local Union 259 Trust Funds

PREVIOUS EMPLOYMENT

Foreman - Lord Electric Company, Inc., Ipswich Water Treatment Facility, Ipswich, MA
Foreman - Peabody New England, Moran Terminal, Massport
General Foreman - New England Power Service Co. - Coal Conversion Project, Salem, MA
Superintendent - Wm. Gens & Son, Inc., Lowell Sun/Father John Apartment Complex,
Lowell, MA
Foreman - Koning Corp. Beverly High School Photovoltaic Project, Beverly, MA
Foreman - Fischbach-Boulos-Manzi Inc., Seabrook Nuclear Station
Director of Facilities, City of Salem, School Department
December 1991 through August 2018



CITY OF SALEM, MASSACHUSETTS

Kimberley Driscoll
Mayor

Office of the Mayor

July 18, 2019

Salem City Council
City Hall
93 Washington Street
Salem, MA 01970

Ladies and Gentlemen of the City Council:

I am very pleased to appoint Rachel McCarter of 17 Forest Avenue #7 of to serve as a regular member of the Salem Tree Commission. Ms. McCarter is appointed to a three-year term to expire July 18, 2022. This seat, specified in Section 43-12(a)(7) is vacant as this Commission is newly established.

Ms. McCarter is a senior project engineer for New England Civil Engineering Corp. and holds her Massachusetts E.I.T. Certification. She received a Bachelor of Science degree in Environmental Engineering from the University of New Hampshire and a Master of Science degree in Geo-Information Science from Salem State. She is a member of the American Society of Civil Engineers, Water Environment Federation, and the New England Water Environment Association. She has worked since 2003 on a wide variety of engineering and public works projects here in Salem and across the region.

We are fortunate Ms. McCarter is willing to serve Salem in this capacity and bring her knowledge and skills to the Commission and its work. I strongly recommend confirmation of her appointment.

Very truly yours,

Kimberley Driscoll
Mayor
City of Salem

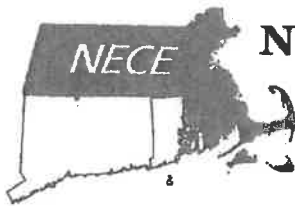

NEW ENGLAND CIVIL ENGINEERING CORP.

265 ESSEX STREET, SUITE 102, P.O. BOX 3026, SALEM, MA 01970
PH: 978.741.7401 - WWW.ENGINEERINGCORPORATION.COM

Rachel L. McCarter, E.I.T., M.Sc. *Senior Project Engineer*

Background

Ms. McCarter has been involved with various engineering and public works projects since 2003. Her experience includes utility design, geographic information systems (GIS) mapping of utility infrastructure, inflow and infiltration (I/I) studies, sanitary sewer evaluation surveys (SSES), manhole inspections and internal building investigations, stormwater mapping in conformance with EPA MS4 NPDES regulations, field investigations for preliminary designs and planning for sewer separation projects, site plan reviews, AutoCAD design, and construction administration. Projects include planning and field investigations, design, and construction administration of utility replacement projects, GPS survey and creation of City-wide sanitary and storm sewer system maps, and permitting.

Engineering and Construction Inspection Experience with NECE

Fowler Street Utility Replacement Project – North Pine, Fowler, and Federal Streets (2019-present) *Salem, MA*

Rachel served as design engineer on the multi-street water, sewer, and drain replacement project totaling approximately \$650,000, involving temporary water main bypass, valve replacement, water main and service replacement, sewer main and manhole replacement, drain replacement, and temporary and permanent paving. Responsibilities include coordination and oversight of gas utility relocation by National Grid, resident and stakeholder notification, traffic and parking coordination, observation and documentation of work in compliance with contract documents, measurement for payment, measuring work for payment, tabulation of payment requests, and preparation of tie cards and sketches for record drawings.

Sanitary Sewer Relocation Project, Various Streets (2019-present) *Gloucester, MA*

Rachel is serving as the design engineer and construction administrator of a multi-street water, sewer, and drain replacement project totaling approximately \$700,000, involving sewer force main replacement on busy Bass Avenue, sewer bypass pumping and piping, CSO sewer overflow regulator and tide gate replacement, and installation of cured-in-place lining in gravity sewers in various locations to address identified deficiencies and remove sources of inflow and infiltration.

PROFESSIONAL QUALIFICATIONS

E.I.T. Certification, State of MA

M.Sc., Geo-Information Science, Salem State University

B.S., Environmental Engineering, University of New Hampshire

A.S., Environmental Systems Technology, Wentworth Institute of Technology

PACP User Training (including manholes) through NASSCO Pipeline Assessment & Certification Program, Certificate No. U-110-9849

OSHA 40-Hour Training

PROFESSIONAL AFFILIATIONS

American Society of Civil Engineers

Water Environment Federation

New England Water Environment Association

Essex County Highway Association

National Association of Sewer Service Companies

Rachel L. McCarter, E.I.T.

Senior Project Engineer

Water Main Replacement – Various Locations (2018-2019)

Salem, MA

Rachel served as the project engineer and construction administrator of a multi-street water main replacement project totaling approximately \$1,500,000, involving temporary water main bypass, valve replacement, water main and service replacement, and temporary and permanent paving. Project involved traffic coordination and detours, night work, community meetings, and public outreach. Responsibilities include resident and stakeholder notification, traffic and parking coordination, observation and documentation of work in compliance with contract documents, measurement for payment, measuring work for payment, tabulation of payment requests, and preparation of tie cards and sketches for record drawings.

Water Main Replacement – Massachusetts Avenue (2018)

Danvers, MA

David served as the project engineer and construction administrator of a multi-street water main replacement project totaling approximately \$700,000, involving temporary water main bypass, valve replacement, water main and service replacement, and temporary and permanent paving. Responsibilities include resident and stakeholder notification, traffic and parking coordination, observation and documentation of work in compliance with contract documents, measurement for payment, measuring work for payment, tabulation of payment requests, and preparation of tie cards and sketches for record drawings.

Jeffrey's Neck Water Main Replacement Project (2013-2014)

Ipswich, MA

Rachel is involved with the design, permitting, and bidding of this \$1.5 million project which involves removal and replacement of 9,000 linear feet of 12-inch and 8-inch water mains including replacement of valves, hydrants, and services. Project involves coordination with other utilities, permitting through MassDEP and Conservation Commission due to surrounding resource areas, support of existing utilities, design and layout of temporary water bypass to hydrants and services during construction, and development of traffic and pedestrian management plan. Coordination with MassDEP State Revolving Fund Program for financial assistance and technical approval.

Phase III, CSO Control Plan, Project #3 (2013-2014)

Gloucester, MA

Rachel assisted with the design and construction administration of this \$2.0 million project involving sewer separation, utility replacement, and roadway reconstruction on various streets in downtown Gloucester. Project involved removal and replacement of all utilities including sewer, drain, and water pipes and services. Project involved stripping and removal of road surface, curbs, and sidewalks on several streets as well as installation of new 8-inch to 24-inch sanitary sewers, 12-inch to 18-inch drain pipes, and 6-inch to 12-inch water mains as well as hydrants, and services. Project involved modification of existing sewer/drain regulator structures, installation of new gate valves, fire hydrants, and copper services from the new water main to the property line; installation of tapping sleeves and valves, establishment of temporary water bypass for domestic water and fire service, and temporary paving. Project involved complete roadway construction including ADA ramps, sidewalks, curbs, pavement, and street trees. Project was located in busy intersection with heavy pedestrian traffic, project involved significant traffic and pedestrian management. Rachel is responsible for field investigations, design and development of contract documents, review of shop drawings, attendance at meetings, review and processing of RFIs and payment requisitions, and contract closeout and MassDEP coordination with regard to technical approval and payment reimbursement.



Rachel L. McCarter, E.I.T.

Senior Project Engineer

Phase III, CSO Control Plan, Project #1 (2012-2013)

Gloucester, MA

Rachel assisted with the design and construction administration of this \$2.5 million project involving sewer separation, utility replacement, and roadway reconstruction on various streets in downtown Gloucester. Project involved removal and replacement of all utilities including sewer, drain, and water pipes and services. Project involved stripping and removal of road surface, curbs, and sidewalks on several streets as well as installation of new 8-inch to 24-inch sanitary sewers, 12-inch to 18-inch drain pipes, and 6-inch to 12-inch water mains as well as hydrants, and services. Project involved modification of existing sewer/drain regulator structures, installation of new gate valves, fire hydrants, and copper services from the new water main to the property line; installation of tapping sleeves and valves, establishment of temporary water bypass for domestic water and fire service, and temporary paving. Project involved complete roadway construction including ADA ramps, sidewalks, curbs, pavement, and street trees. Project was located in busy intersection with heavy pedestrian traffic, project involved significant traffic and pedestrian management. Rachel is responsible for field investigations, design and development of contract documents, review of shop drawings, attendance at meetings, review and processing of RFIs and payment requisitions, and contract closeout and MassDEP coordination with regard to technical approval and payment reimbursement.

Becket Street Utility Replacement Project (2012)

Salem, MA

Rachel assisted with the design, permitting, and construction management of this \$1,000,000 project involving removal and replacement of all utilities on Becket Street, between Derby Street and Essex Street, including some utility replacement on Essex Street, Forrester Street, and Emerton Street. Project involved stripping and removal of road surface, curbs, and sidewalks as well as installation of new 15-inch drain pipe and catch basins, replacement of sanitary sewer pipe and services, and replacement of water main, hydrants, and services. Project involved installation of new gate valves, fire hydrants, and copper services from the new water main to the property line; installation of tapping sleeves and valves, establishment of temporary water bypass for domestic water and fire service, and temporary paving. Project involved complete roadway construction including ADA ramps, sidewalks, curbs, pavement, and street trees. Project was located in busy intersection with heavy pedestrian traffic, project involved significant traffic and pedestrian management.

Town-wide I/I Study and Rehabilitation Project (2012)

Ipswich, MA

As Project Manager and Construction Inspector, Rachel was responsible supervising construction, recording an accurate field book, and reviewing payment requisitions. The project involved reviewing historical and metered flows received at the WWTF in Ipswich, MA; completing field investigations and identifying locations for flow meter placement; installing and maintaining 5 flow meters, 1 rain gage, and 1 groundwater surface gage for three-week period in Spring 2009; completing field investigations and GIS mapping of priority sanitary and storm sewer infrastructure; identifying locations of potential groundwater infiltration; coordinating with outside pipeline maintenance company to complete manhole rehabilitation, pipeline and siphon cleaning and CCTV, joint testing and sealing, lateral investigations and sealing, and cast-in-place spot repair lining; and preparing letter reports including graphs, tables, charts, and photographs documenting process and findings.

Inflow Source Removal Project, Design and Construction Administration (2009-2010)

Gloucester, MA

Rachel's responsibilities include preparation of design plans and technical specifications to repair the sewer system and/or remove sources of saline and rainfall inflows identified in previous studies. Design involves review of historical data, field investigations, utility survey, smoke and dye testing, preparation of schematic



Rachel L. McCarter, E.I.T.

Senior Project Engineer

design drawings, preparation of contract specifications, solicitation of quotes from contractors, and administration of construction activities.

PWS Upgrade – Phase 1A/Phase 1B, Babson Water Treatment Facility (2009-2011)

Gloucester, MA

Rachel served as Design Engineer for the Phase 1A/1B projects involving \$4.5 million water treatment facility upgrades including new buried water, sewer, and drain pipes and structures as well as internal pumps, piping, and equipment. Rachel was responsible for preparing construction documents, assisting with the bidding process, and reviewing shop drawing submittals. The project involved rehabilitation and replacement of several major components of the Babson Water Treatment Facility as well as rehabilitation of raw water intake structures located at the Babson, Goose Cove, Dykes, Wallace, and Haskell reservoirs throughout the City of Gloucester.

Dove Ave. Culvert Replacement Project

Salem, MA

As Design Engineer, Rachel was responsible for survey, design, and administration for this \$221,000 project involving removal and disposal of existing corrugated metal pipe culverts conveying the South River; installation of new HDPE pipe and suitable bedding for new pipes; bypass pumping; repair and replacement of pavement, curb, sidewalk, and masonry riprap embankments; support of utilities, traffic control, and all appurtenant work.

Sanitary and Storm Sewer Infrastructure Mapping

Gloucester, MA

Complete field investigations within the combined sewer catchment areas discharging to CSO-004, 005, 006, and 009 in Gloucester harbor. Review existing information (GIS layers, manhole inspections, geodatabase) and develop City-wide drainage infrastructure mapping of all infrastructure including inlets, outfalls, headwalls, catch basins, manholes, and non-structural drainage. Complete field work with GPS handheld data collectors, deliver electronic and hard copies of GIS system maps.

South River Drainage System, Illicit Sewer Connection Survey and Remediation

Salem, MA

Investigate suspect illicit sanitary sewer connections to the urban river (South River) discharging to the Salem Sound. Project involved field investigations and mapping of adjacent sanitary and storm water infrastructure, sampling and dye testing to narrow down the target study area, and repeated rounds of sampling and dye testing upstream until suspect source(s) were identified. Coordinate with City DPW and/or outside contractors to clean structures and pipelines and CCTV inspections as necessary to identify the suspect sources. Prepare design drawings to remove the illicit connections from the river and confirm improvement with follow-up sampling. Coordinate with City Engineering Department on DEP notification and progress reports.

Forrester Street Neighborhood, Drainage Investigation and Upgrades

Salem, MA

In response to flooding, complete field investigations, GPS survey, and GIS mapping of drainage catchment area including City owned drainage and outfall on the facility of the Dominion power plant in the Salem Sound. Evaluate alternatives to improve drainage including heavy cleaning and internal inspections (CCTV), installation of new tide gate and drainage improvements, evaluate options, prepare cost to benefit analysis.

Derby Street Drainage outfall, Illicit Sewer Connection Survey and Remediation

Salem, MA



Rachel L. McCarter, E.I.T.

Senior Project Engineer

Investigate suspect illicit sanitary sewer connections to the Derby Street drainage catchment area which discharges to the Salem Sound in the vicinity of Derby Wharf in Salem, MA. Project involved field investigations, GPS survey, and GIS mapping of adjacent sanitary and storm water infrastructure, sampling and dye testing to narrow down the target study area, and repeated rounds of sampling and dye testing upstream until suspect source(s) were identified. Coordinate with City DPW and/or outside contractors to clean structures and pipelines and CCTV inspections as necessary to identify the suspect sources. Prepare design report and opinion of findings for the City of Salem to submit to MassDEP in response to Administrative Consent Order.

City-wide I/I Study – City of Salem, MA

South Essex Sewerage District

Review historical tide, rainfall, and metered flows received at the SESD WWTF. Complete field investigations and identify locations for flow meter placement. Install and maintain 23 flow meters, 1 rain gage, and 6 water surface gages for nine weeks in the Spring of 2008. Analyze data and prioritize meter sub-catchment areas based on observed inflow and infiltration. Complete field investigations and GIS mapping of all sanitary and storm sewer infrastructure within the City of Salem limits. Develop GIS maps of sanitary and storm sewer infrastructure. Identify locations of potential saline or rainfall inflows and confirm connectivity with system using smoke and dye testing around low tide conditions. Prepare letter report including graphs, tables, charts, and photographs documenting process and findings.

I/I Study - Saline Inflow Study

Gloucester, MA

Review historical tide and WWTF flow data and determine extent of saline inflow influence in the collection system and the relative influence versus varying tide heights. Review historical data and identify sewer infrastructure susceptible to saline inflows. Collect samples and readings of conductivity, temperature, and salinity in multiple manholes in susceptible areas during target tidal cycles. Install multiple flow (depth-velocity) meters in areas and plot flow, temperature, and conductivity versus tide heights recorded on temporary meter. Identify locations of saline inflows and confirm connectivity with system using smoke and dye testing around low tide conditions. Prepare letter report including graphs, tables, charts, and photographs documenting process and findings.

SSES, Combined Sewer Overflow Catchment Areas

Gloucester, MA

Perform sanitary sewer evaluation survey to determine connectivity and condition of existing combined sewer infrastructure within catchment areas tributary to several combined sewer system regulator structures including (CSO-004, 005-1, 005-2, 006, 006A, and 009). Field work (SSES) includes surface manhole inspections, internal building investigations, dye testing and flooding in conjunction with GPS surveying. Update GIS system map and populate geo-database with findings, photos, and GPS coordinates.

CSO-(004, 005-1, 005-2, 006, 006A, and 009) Combined Sewer Catchment Area, Hydraulic Model, and Regulator Modification Study

Gloucester, MA

Revise schematic GIS map within CSO-004, 005-1, 005-2, 006, 006A, and 009 catchments to include depths, slopes, material, and condition of pipes and manholes. Prepare rainfall-runoff model using InfoWorks CS by Wallingford Software. Calibrate model based on three years of metering data, orthophotos, land use, topography, impervious area calculations, slopes, infiltration base flow, water use and population distribution records, and operating parameters of existing flow regulator structures and main interceptor sewer. Develop alternatives to reduce the frequency and intensity of overflows while avoiding surcharge conditions at the WWTF inlet. Model scenarios incorporating each alternative and prepare a cost-to-benefit analysis and letter report.





CITY OF SALEM, MASSACHUSETTS

Kimberley Driscoll
Mayor

Office of the Mayor

July 18, 2019

Salem City Council
City Hall
93 Washington Street
Salem, MA 01970

Ladies and Gentlemen of the City Council:

I am pleased to appoint Charlotte Enfield of 19 Willow Avenue to serve as an alternate member of the Salem Tree Commission. Ms. Enfield is appointed to a 3-year term expiring July 18, 2022. This seat, specified in Section 43-12(a)(6) is vacant as the Commission is newly established.

Ms. Enfield is an International Society of Arboriculture certified arborist and tree risk assessor. She has worked in a variety of capacities on arboreal maintenance and forestry, including time with the Trustees of Reservations, Padilla Tree and Bartlett Tree Experts in New York, and Savatree in Beverly. Today she owns and works in her own firm, Spruced Up Tree and Shrub. Ms. Enfield holds a Bachelor's of Science degree in Forestry from Virginia Polytechnic Institute and State University. While a student there, she completed forestry internships at the U.S. National Arboretum, City of New York Parks Department, and Arnold Arboretum.

We are fortunate Ms. Enfield is willing to serve our community in this capacity and lend her expertise to the Commission and its work. I strongly recommend confirmation of her appointment.

Very truly yours,

Kimberley Driscoll
Mayor
City of Salem

Charlotte Enfield

19 Willow Ave #1
Salem, MA 01970

C: 978-595-7855

c.enfield@comcast.net

-
- JOB OBJECTIVES**
- Lead Arborist; managing trees wisely, balancing preservation with urban growth and client's needs
 - Managing and directing long and short term tree care projects

- EDUCATION & SKILLS**
- **Bachelor of Science in Forestry**, May 2005. Virginia Polytechnic Institute and State University, Blacksburg, Virginia
 - ISA Certified Arborist Nov. 2010-current
 - ISA Tree Risk Assessment Qualified March 2016-current
 - TCIA EHAP Competition 2016- current
 - 2012 MA CDL Class B Obtained (expired)
 - 2012 MA Pesticide Applicator's License (expired)
 - Husqvarna Chain Saw Applications Training, November '08
 - Have used Davey's Tree Keeper 7.4 Inventory System, GIS programs; ArcMap, Arc Catalog, ArcToolbox, Terra Sync, Active Sync, Trimble GPS Hardware.

- COURSEWORK**
- Soils in the Landscape
 - Plant Pathology
 - Woody Plant ID
 - Dendrology
 - Forest Biology
 - Agroforestry
 - Forested Wetlands
 - Forest Measurements
 - Urban Forestry & Arboriculture
 - Forest Photogrammetry
 - Forest Ecology and Silvics
 - Silviculture
 - Outdoor Recreation
 - Vertebrate Pest Management
 - Environmental Design and Sustainability

- WORK EXPERIENCE**
- Owner/Arborist/Tree Climber at Spruced Up Tree and Shrub 2014-Current
 - Savatree Beverly, MA, PHC tech, 2012
 - Bartlett Tree Experts Climber/Ground/Bucket Elmsford, NY 2011
 - Padilla Tree, Groundsperson, Bronx, NY 2010
 - The Trustees of Reservations Long Hill Reservation Maintenance Technician. Beverly, MA 2006-2010
 - Arnold Arboretum Intern, summer 2005 and 6-month temp.
 - City of New York Parks and Recreation Central Forestry Intern, summer 2004
 - United States National Arboretum Intern, summer 2003

ACTIVITIES

- Tree Care Industry Expo 2003, 2011, 2014
- New England Wildflower Society Member 2007
- New England Grows, Boston, MA 2006, 2008
- Society of American Foresters Member 2002-2003
- SAF National Convention, Buffalo, NY, Fall 2003
- The 2001 National Urban Forestry Conference, Washington DC

REFERENCES

- Paul Decker, Tewksbury School Groundskeeper + Former Tree Crew Foreman (720)-933-4489
- Frazer Pehmoeller, Bartlett Representative, (914) 879-9757
fpehmoeller@bartlett.com
- Daniel Bouchard, Long Hill Superintendent, (978) 524-1870



CITY OF SALEM, MASSACHUSETTS

Kimberley Driscoll
Mayor

Office of the Mayor

July 18, 2019

Salem City Council
City Hall
93 Washington Street
Salem, MA 01970

Ladies and Gentlemen of the City Council:

I am very pleased to appoint Rehana Yusif of 260 Washington Street #37 of to serve as one of the two adult members of the Salem Youth Commission. Ms. Yusif will complete the remainder of an unexpired three-year term to conclude on June 23, 2022. She will take the seat previously held by Michael Quigley.

Ms. Yusif is currently a Spanish teacher at Salem High School and, previous to that, had been a science teacher in an after-school program and a camp counselor. In all of these positions she has worked directly with children and youth, helping them to grow and to learn. Ms. Yusif earned a Bachelor's degree from Westfield State University and a Master's degree in Teaching Spanish from Salem State University.

We are fortunate Ms. Yusif is willing to step into this role and to serve our community. I strongly recommend confirmation of her appointment to the Youth Commission as one of the two adult members.

Very truly yours,

Kimberley Driscoll
Mayor
City of Salem

Rehana Yusif

260 Washington St. Apt. 37 Salem, MA 01970 • (978) 235-6523 • Rehanayusif@yahoo.com

EDUCATION

Salem State University, Salem, MA May 2020
Masters of Arts, Teaching Spanish GPA: 3.87/4.00
Westfield State University, Westfield, MA May 2017
Bachelor of Science, Criminal Justice GPA: 3.457/4.00
Bachelor of Arts, Spanish

ACADEMIC ACHIEVEMENTS

Dean's List – 7/8 Semesters
National Honor Society
Spanish Honor Society
Academic Excellence Award

GLOBAL EXPERIENCE

Pontificia Universidad Católica Madre y Maestra Santiago, DR January – April 2016

- Volunteered in Puerto Plata, Santiago and Santo Domingo
- Built a hospital and informed residents on the environment and their health
- Maintained a GPA of 3.95/4.00

COLLEGIATE LEADERSHIP

Graduate Assistant – Center For Academic Excellence September 2017 – May 2019

- Collect information about tutoring and SI program
- Create various diagrams based on data collection

Class Council Representative – Student Government Association September 2015 – May 2017

- Report information back to constituents
- Vote on important issues regarding finances, new laws and amendments
- Serve as the Chair of The Food Committee

Residential Assistant – Davis Hall, University Hall August 2014 – May 2017

- Help create a cooperative educational/community environment which contributes to the academic and personal growth and success of each resident

Orientation Leader – Admissions Department June 2014

- Assisted the incoming freshman and transfer students through the transition necessary for a successful college experience
- Provided new students and parents with an introduction to the campus and its resources

EMPLOYMENT

Spanish Teacher, Salem High School August 2017 - Present

- Assess and provide support to 120 student throughout the year
- Maintain discipline in the classroom
- Meet with parents and school administrators in a professional capacity

After School Science Teacher, Mad Science of Western New England September – December 2016

- Create a fun and enjoyable learning environment while teaching up to 20 elementary aged children

Camp Counselor, The Summer Camp, Washington, ME June – August 2017

- Helped create a safe environment for at risk children

- Planned, coordinated, and facilitated activities while guiding campers in personal growth and daily living skills

Packer, Industrial Packaging, Leominster, MA

July 2015 – August 2016

- Responsible for placing chips in boxes, piling boxes into the correct order and preparing them for shipment using various equipment
- Responsible for the translating from English to Spanish in order to relate office needs to line workers

SKILLS

Languages: Twi, and Spanish

Computer: Microsoft Word, Excel, PowerPoint



CITY OF SALEM, MASSACHUSETTS

Kimberley Driscoll
Mayor

July 18, 2019

Honorable Salem City Council
Salem City Hall
Salem, Massachusetts 01970

Ladies and Gentlemen of the City Council:

I reappoint, subject to City Council confirmation, Ms. Datanis Elias, of 71 Harbor Street, to the Board of Health for a term of 3 years to expire 7/21/2022.

I recommend confirmation of her reappointment to the board and ask that you join me in thanking Ms. Elias for her continued dedicated service and commitment to our community.

Very truly yours,

A handwritten signature in cursive script that reads "Kim Driscoll".

Kimberley Driscoll
Mayor
City of Salem



CITY OF SALEM, MASSACHUSETTS

Kimberley Driscoll
Mayor

July 18, 2019

Honorable Salem City Council
Salem City Hall
Salem, Massachusetts 01970

Ladies and Gentlemen of the City Council:

I reappoint, subject to City Council confirmation, Mr. John Andrews, of 9 English Street #1, to the Public Art Commission for a term of 2 years to expire 7/20/2021.

I recommend confirmation of his reappointment to the board and ask that you join me in thanking Mr. Andrews for his continued dedicated service and commitment to our community.

Very truly yours,

A handwritten signature in black ink that reads "Kim Driscoll". The signature is written in a cursive, flowing style.

Kimberley Driscoll
Mayor
City of Salem



CITY OF SALEM

In City Council,

Ordered:

July 18, 2019

That the sum of Five Hundred Twenty-Nine Thousand and Forty dollars and Seventy-Two Cents (\$529,040.72) is hereby appropriated from General Fund Balance Reserved for Free Cash (1-3245) to the following special revenue funds. This transfer is requested in accordance with the recommendation of Her Honor the Mayor.

Fund Name/Description	Amount
Capital Improvement Fund 2000	\$ <u>529,040.72</u>



CITY OF SALEM, MASSACHUSETTS

Kimberley Driscoll
Mayor

Office of the Mayor

July 18, 2019

Salem City Council
City Hall
93 Washington Street
Salem, MA 01970

Ladies and Gentlemen of the City Council:

The enclosed Order is our routine end-of-the-fiscal-year transfer of remaining free cash from the prior fiscal year to the capital improvement fund. This year, the amount of this transfer is \$529,040.72.

I recommend adoption of the enclosed Order and invite you to contact Laurie Giardella should you have any questions about this request.

Very truly yours,

Kimberley Driscoll
Mayor
City of Salem



CITY OF SALEM

In City Council,

Ordered:

July 18, 2019

That the sum of Two Hundred Sixty-Five Thousand Six Hundred and Forty-Eight Dollars and Zero Cents (\$265,648.00) in the "Retirement Stabilization Fund-Vacation/Sick Leave Buyback" account (83113-5146) to be expended for the FY2020 contractual buybacks listed below in accordance with the recommendation of Her Honor the Mayor.

Name	Department	Amount
Catherine Marquardt	School	16,358.80
Nancy Antrim	School	34,080.00
Susan Marsh	School	17,582.40
Bonnie Muse	School	33,854.40
Donna Pelletier	School	16,877.60
Joyce Parent	School	36,839.20
Linda Connell	School	34,764.80
Janet Harrison	School	19,485.60
Donna Silvio	School	31,254.40
Gail Kucker	School	24,550.80
		265,648.00



CITY OF SALEM, MASSACHUSETTS

Kimberley Driscoll

Mayor

July 18, 2019

To the City Council
City Hall
Salem, Massachusetts

Ladies and Gentlemen of the Council:

Enclosed herewith is a request for an appropriation of Two Hundred Sixty-Five Thousand Six Hundred and Forty-Eight Dollars and Zero Cents (\$265,648.00) from the "Retirement Stabilization Fund-Vacation/Sick Leave Buyback" account (83113-5146).

This transfer is necessary to fund the retirement buyback for School Department employees.

Name	Department	Amount
Catherine Marquardt	School	16,358.80
Nancy Antrim	School	34,080.00
Susan Marsh	School	17,582.40
Bonnie Muse	School	33,854.40
Donna Pelletier	School	16,877.60
Joyce Parent	School	36,839.20
Linda Connell	School	34,764.80
Janet Harrison	School	19,485.60
Donna Silvio	School	31,254.40
Gail Kucker	School	24,550.80
	TOTAL:	\$265,648.00

I recommend passage of the accompanying Order.

Very truly yours,

A handwritten signature in black ink, appearing to read "Kim Driscoll", written over the typed name.

Kimberley Driscoll
Mayor

CITY OF SALEM
APPROVAL-SICK DAYS/VACATION BUY-BACK

From: Department _____ School _____ Date 6/10/19

Authorized Signature: [Signature]
Department Head/City or Business Manager/School

NAME: Gail Kucker

CALCULATION

VACATION DAYS # 33 @ \$ 199⁶⁰ = \$ 6586.80 ✓
SICK DAYS # 90 @ \$ 199⁶⁰ = \$ 17,964- ✓
PRO-RATED STIPENDS # _____ @ \$ _____ = \$ _____
OTHER # _____ @ \$ _____ = \$ _____

Total Amount Due: \$24,550.80 ✓
Please attach corresponding PAF or other backup to this sheet.

Reason: Death 6/9/19
Payable to estate

For Human Resources's Use Only:

- VACATION DAYS
- SICK DAYS
- PER ACCRUAL REPORT
- OTHER

Org and Object: 83113 - 5146

Recommendation:

Approved
[Signature]

[Signature]
H R Director/City or Superintendent/Schools



CITY OF SALEM MASSACHUSETTS

HUMAN RESOURCES
98 WASHINGTON STREET, 3RD FLOOR
SALEM, MASSACHUSETTS 01970
TEL. 978-619-5630
FAX 978-745-7298

KIMBERLEY L. DRISCOLL
MAYOR

LISA B. CAMMARATA
DIRECTOR OF HUMAN
RESOURCES

MEMORANDUM

TO: Laurie Giardella, Director of Finance
DATE: June 28, 2019
RE: Retirement Stabilization Fund

Attached you will find a retirement buy back for a former employee of the Salem Public Schools.

This former employee is contractually entitled to the following amount of sick leave buyback.

Gail Kucker

90 sick days @ \$199.60 per day	\$17,964.00
33 vacation days @ \$199.60 per day	\$ 6,586.80
Total:	\$24,550.80

In accordance with the July 2008 Policy, I am requesting you verify the availability of the funds from the Retirement Stabilization Fund, prepare the Council Order, and continue the process in order that my staff can input the information in MUNIS and issue payments to this former employee upon Council approval.

Thank you for your cooperation, and if you should have any questions, please do not hesitate to contact me.

CITY OF SALEM
APPROVAL-SICK DAYS/VACATION BUY-BACK

From: Department _____ School _____ Date 6/24/19

Authorized Signature: 
 Department Head/City or Business Manager/School

NAME: Donna Silvio

CALCULATION

VACATION DAYS # _____ @ \$ _____ = \$ _____

SICK DAYS # 80 @ \$ 390.68 = \$ 31,254.40 ✓

PRO-RATED STIPENDS # _____ @ \$ _____ = \$ _____

OTHER # _____ @ \$ _____ = \$ _____

Total Amount Due: \$ 31,254.40
 Please attach corresponding PAF or other backup to this sheet.

Reason: Retirement

For Human Resources's Use Only:

- VACATION DAYS
- SICK DAYS
- PER ACCRUAL REPORT
- OTHER

Org and Object: 831/3 - 5146

Recommendation:

Approved

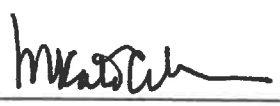

 H R Director/City or Superintendent/Schools



CITY OF SALEM MASSACHUSETTS

HUMAN RESOURCES
98 WASHINGTON STREET, 3RD FLOOR
SALEM, MASSACHUSETTS 01970
TEL. 978-619-5630
FAX 978-745-7298

KIMBERLEY L. DRISCOLL
MAYOR

LISA B. CAMMARATA
DIRECTOR OF HUMAN
RESOURCES

MEMORANDUM

TO: Laurie Giardella, Director of Finance
DATE: June 28, 2019
RE: Retirement Stabilization Fund

Attached you will find a retirement buy back for a former employee of the Salem Public Schools.

This former employee is contractually entitled to the following amount of sick leave buyback.

Donna Silvio

80 sick days @\$390.68 per day \$31,254.40

Total: \$31,254.40

In accordance with the July 2008 Policy, I am requesting you verify the availability of the funds from the Retirement Stabilization Fund, prepare the Council Order, and continue the process in order that my staff can input the information in MUNIS and issue payments to this former employee upon Council approval.

Thank you for your cooperation, and if you should have any questions, please do not hesitate to contact me.

CITY OF SALEM
APPROVAL-SICK DAYS/VACATION BUY-BACK

From: Department _____ School _____ Date 6/24/19

Authorized Signature: [Signature]
Department Head/City or Business Manager/School

NAME: Janet Harrison

CALCULATION

VACATION DAYS # _____ @ \$ _____ = \$ _____
SICK DAYS # 40 @ \$ 487.14 = \$ 19,485.60
PRO-RATED STIPENDS # _____ @ \$ _____ = \$ _____
OTHER # _____ @ \$ _____ = \$ _____

Total Amount Due: \$ 19,485.60
Please attach corresponding PAF or other backup to this sheet.

Reason: Retirement

For Human Resources's Use Only:

- VACATION DAYS
- SICK DAYS
- PER ACCRUAL REPORT
- OTHER

Org and Object: 83113 - 5146

Recommendation:

Approved
[Signature]

[Signature]
H R Director/City or Superintendent/Schools



CITY OF SALEM MASSACHUSETTS

**HUMAN RESOURCES
98 WASHINGTON STREET, 3RD FLOOR
SALEM, MASSACHUSETTS 01970
TEL. 978-619-5630
FAX 978-745-7298**

**KIMBERLEY L. DRISCOLL
MAYOR**

**LISA B. CAMMARATA
DIRECTOR OF HUMAN
RESOURCES**

MEMORANDUM

TO: Laurie Giardella, Director of Finance
DATE: June 28, 2019
RE: Retirement Stabilization Fund

Attached you will find a retirement buy back for a former employee of the Salem Public Schools.

This former employee is contractually entitled to the following amount of sick leave buyback.

Janet Harrison

40 sick days @\$487.14 per day **\$19,485.60**

Total: \$19,485.60

In accordance with the July 2008 Policy, I am requesting you verify the availability of the funds from the Retirement Stabilization Fund, prepare the Council Order, and continue the process in order that my staff can input the information in MUNIS and issue payments to this former employee upon Council approval.

Thank you for your cooperation, and if you should have any questions, please do not hesitate to contact me.

CITY OF SALEM
APPROVAL-SICK DAYS/VACATION BUY-BACK

From: Department _____ School _____ Date 6/24/19

Authorized Signature: [Signature]
Department Head/City or Business Manager/School

NAME: Linda Connell

CALCULATION

VACATION DAYS # _____ @ \$ _____ = \$ _____

SICK DAYS # 80 @ \$ 434.56 = \$ 34,764.80

PRO-RATED STIPENDS # _____ @ \$ _____ = \$ _____

OTHER # _____ @ \$ _____ = \$ _____

Total Amount Due: \$ 34,764.80
Please attach corresponding PAF or other backup to this sheet.

Reason: Retirement

For Human Resources's Use Only:

VACATION DAYS

SICK DAYS

PER ACCRUAL REPORT

OTHER

Org and Object: 83113 - 5146

Recommendation:

Approved
[Signature]

[Signature]
H R Director/City or Superintendent/Schools



CITY OF SALEM MASSACHUSETTS

**KIMBERLEY L. DRISCOLL
MAYOR**

**LISA B. CAMMARATA
DIRECTOR OF HUMAN
RESOURCES**

**HUMAN RESOURCES
98 WASHINGTON STREET, 3RD FLOOR
SALEM, MASSACHUSETTS 01970
TEL. 978-619-5630
FAX 978-745-7298**

MEMORANDUM

TO: Laurie Giardella, Director of Finance
DATE: June 28, 2019
RE: Retirement Stabilization Fund

Attached you will find a retirement buy back for a former employee of the Salem Public Schools.

This former employee is contractually entitled to the following amount of sick leave buyback.

Linda Connell

80 sick days @\$434.56 per day \$34,764.80

Total: \$34,764.80

In accordance with the July 2008 Policy, I am requesting you verify the availability of the funds from the Retirement Stabilization Fund, prepare the Council Order, and continue the process in order that my staff can input the information in MUNIS and issue payments to this former employee upon Council approval.

Thank you for your cooperation, and if you should have any questions, please do not hesitate to contact me.

CITY OF SALEM
APPROVAL-SICK DAYS/VACATION BUY-BACK

From: Department _____ School _____ Date 6/24/19

Authorized Signature: [Signature]
Department Head/City or Business Manager/School

NAME: Joyce Parent

CALCULATION

VACATION DAYS # _____ @ \$ _____ = \$ _____

SICK DAYS # 80 @ \$ 460.49 = \$ 36,839.20

PRO-RATED STIPENDS # _____ @ \$ _____ = \$ _____

OTHER # _____ @ \$ _____ = \$ _____

Total Amount Due: \$ 36,839.20
Please attach corresponding PAF or other backup to this sheet.

Reason: Retirement

For Human Resources's Use Only:

- VACATION DAYS
- SICK DAYS
- PER ACCRUAL REPORT
- OTHER

Org and Object: 83113 - 5146

Recommendation:

Approved
[Signature]

[Signature]
H R Director/City or Superintendent/Schools



CITY OF SALEM MASSACHUSETTS

**KIMBERLEY L. DRISCOLL
MAYOR**

**LISA B. CAMMARATA
DIRECTOR OF HUMAN
RESOURCES**

**HUMAN RESOURCES
98 WASHINGTON STREET, 3RD FLOOR
SALEM, MASSACHUSETTS 01970
TEL. 978-619-5630
FAX 978-745-7298**

MEMORANDUM

TO: Laurie Giardella, Director of Finance
DATE: June 28, 2019
RE: Retirement Stabilization Fund

Attached you will find a retirement buy back for a former employee of the Salem Public Schools.

This former employee is contractually entitled to the following amount of sick leave buyback.

Joyce Parent

80 sick days @ \$460.49 per day \$36,839.20

Total: \$36,839.20

In accordance with the July 2008 Policy, I am requesting you verify the availability of the funds from the Retirement Stabilization Fund, prepare the Council Order, and continue the process in order that my staff can input the information in MUNIS and issue payments to this former employee upon Council approval.

Thank you for your cooperation, and if you should have any questions, please do not hesitate to contact me.

CITY OF SALEM
APPROVAL-SICK DAYS/VACATION BUY-BACK

From: Department _____ School _____ Date 6/24/19

Authorized Signature: [Signature]
 Department Head/City or Business Manager/School

NAME: Donna Pelletier

CALCULATION

VACATION DAYS # _____ @ \$ _____ = \$ _____
SICK DAYS # 40 @ \$ 421.94 = \$ 16,877.60
PRO-RATED STIPENDS # _____ @ \$ _____ = \$ _____
OTHER # _____ @ \$ _____ = \$ _____

Total Amount Due: \$ 16,877.60
 Please attach corresponding PAF or other backup to this sheet.

Reason: Retirement

For Human Resources's Use Only:

- VACATION DAYS
- SICK DAYS
- PER ACCRUAL REPORT
- OTHER

Org and Object: 83113 - 5146

Recommendation:

Approved
[Signature]

[Signature]
 H R Director/City or Superintendent/Schools



CITY OF SALEM MASSACHUSETTS

HUMAN RESOURCES
98 WASHINGTON STREET, 3RD FLOOR
SALEM, MASSACHUSETTS 01970
TEL. 978-619-5630
FAX 978-745-7298

KIMBERLEY L. DRISCOLL
MAYOR

LISA B. CAMMARATA
DIRECTOR OF HUMAN
RESOURCES

MEMORANDUM

TO: Laurie Giardella, Director of Finance
DATE: June 28, 2019
RE: Retirement Stabilization Fund

Attached you will find a retirement buy back for a former employee of the Salem Public Schools.

This former employee is contractually entitled to the following amount of sick leave buyback.

Donna Pelletier

40 sick days @ \$421.94 per day **\$16,877.60**

Total: \$16,877.60

In accordance with the July 2008 Policy, I am requesting you verify the availability of the funds from the Retirement Stabilization Fund, prepare the Council Order, and continue the process in order that my staff can input the information in MUNIS and issue payments to this former employee upon Council approval.

Thank you for your cooperation, and if you should have any questions, please do not hesitate to contact me.

CITY OF SALEM
APPROVAL-SICK DAYS/VACATION BUY-BACK

From: Department _____ School _____ Date 6/24/19

Authorized Signature: [Signature]
Department Head/City or Business Manager/School

NAME: Bonnie Muse

CALCULATION

VACATION DAYS # _____ @ \$ _____ = \$ _____
SICK DAYS # 80 @ \$ 423.18 = \$ 33,854.40
PRO-RATED STIPENDS # _____ @ \$ _____ = \$ _____
OTHER # _____ @ \$ _____ = \$ _____

Total Amount Due: \$ 33,854.40
Please attach corresponding PAF or other backup to this sheet.

Reason: Retirement

For Human Resources's Use Only:

- VACATION DAYS
- SICK DAYS
- PER ACCRUAL REPORT
- OTHER

Org and Object: 83113 - 5146

Recommendation:

Approved
[Signature]

[Signature]
H R Director/City or Superintendent/Schools



CITY OF SALEM MASSACHUSETTS

HUMAN RESOURCES
98 WASHINGTON STREET, 3RD FLOOR
SALEM, MASSACHUSETTS 01970
TEL. 978-619-5630
FAX 978-745-7298

KIMBERLEY L. DRISCOLL
MAYOR

LISA B. CAMMARATA
DIRECTOR OF HUMAN
RESOURCES

MEMORANDUM

TO: Laurie Giardella, Director of Finance
DATE: June 28, 2019
RE: Retirement Stabilization Fund

Attached you will find a retirement buy back for a former employee of the Salem Public Schools.

This former employee is contractually entitled to the following amount of sick leave buyback.

Bonnie Muse

80 sick days @ \$423.18 per day **\$33,854.40**

Total: \$33,854.40

In accordance with the July 2008 Policy, I am requesting you verify the availability of the funds from the Retirement Stabilization Fund, prepare the Council Order, and continue the process in order that my staff can input the information in MUNIS and issue payments to this former employee upon Council approval.

Thank you for your cooperation, and if you should have any questions, please do not hesitate to contact me.

CITY OF SALEM
APPROVAL-SICK DAYS/VACATION BUY-BACK

From: Department _____ School _____ Date 6/24/19

Authorized Signature: _____
Department Head/City or Business Manager/School

NAME: Susan Marsh

CALCULATION

VACATION DAYS # _____ @ \$ _____ = \$ _____

SICK DAYS # 40 @ \$ 439.56 = \$ 17,582.40

PRO-RATED STIPENDS # _____ @ \$ _____ = \$ _____

OTHER # _____ @ \$ _____ = \$ _____

Total Amount Due: \$ 17,582.40

Please attach corresponding PAF or other backup to this sheet.

Reason: Retirement

For Human Resources's Use Only:

- VACATION DAYS
- SICK DAYS
- PER ACCRUAL REPORT
- OTHER

Org and Object: 83113 - 5146

Recommendation:

Approved

H R Director/City or Superintendent/Schools



CITY OF SALEM MASSACHUSETTS

HUMAN RESOURCES
98 WASHINGTON STREET, 3RD FLOOR
SALEM, MASSACHUSETTS 01970
TEL. 978-619-5630
FAX 978-745-7298

KIMBERLEY L. DRISCOLL
MAYOR

LISA B. CAMMARATA
DIRECTOR OF HUMAN
RESOURCES

MEMORANDUM

TO: Laurie Giardella, Director of Finance
DATE: June 28, 2019
RE: Retirement Stabilization Fund

Attached you will find a retirement buy back for a former employee of the Salem Public Schools.

This former employee is contractually entitled to the following amount of sick leave buyback.

Susan Marsh

40 sick days @ \$439.56 per day \$17,582.40

Total: \$17,582.40

In accordance with the July 2008 Policy, I am requesting you verify the availability of the funds from the Retirement Stabilization Fund, prepare the Council Order, and continue the process in order that my staff can input the information in MUNIS and issue payments to this former employee upon Council approval.

Thank you for your cooperation, and if you should have any questions, please do not hesitate to contact me.

CITY OF SALEM
APPROVAL-SICK DAYS/VACATION BUY-BACK

From: Department _____ School _____ Date 6/24/19

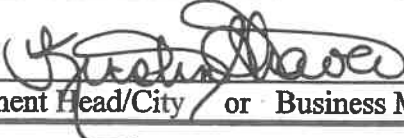
Authorized Signature: 
Department Head/City or Business Manager/School

NAME: Nancy Anteim

CALCULATION

<u>VACATION DAYS</u>	# _____	@ \$ _____	= \$ _____
<u>SICK DAYS</u>	# <u>80</u>	@ \$ <u>426.00</u>	= \$ <u>34,080</u>
<u>PRO-RATED STIPENDS</u>	# _____	@ \$ _____	= \$ _____
<u>OTHER</u>	# _____	@ \$ _____	= \$ _____

Total Amount Due: \$ 34,080
Please attach corresponding PAF or other backup to this sheet.

Reason: Retirement

For Human Resources's Use Only:

- VACATION DAYS
- SICK DAYS
- PER ACCRUAL REPORT
- OTHER

Org and Object: 83113 - 5/46

Recommendation:
 Approved

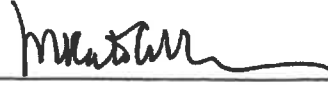

H R Director/City or Superintendent/Schools



CITY OF SALEM MASSACHUSETTS

**KIMBERLEY L. DRISCOLL
MAYOR**

**LISA B. CAMMARATA
DIRECTOR OF HUMAN
RESOURCES**

**HUMAN RESOURCES
98 WASHINGTON STREET, 3RD FLOOR
SALEM, MASSACHUSETTS 01970
TEL. 978-619-5630
FAX 978-745-7298**

MEMORANDUM

TO: Laurie Giardella, Director of Finance
DATE: June 28, 2019
RE: Retirement Stabilization Fund

Attached you will find a retirement buy back for a former employee of the Salem Public Schools.

This former employee is contractually entitled to the following amount of sick leave buyback.

Nancy Antrim

80 sick days @ \$426.00 per day \$34,080.00

Total: \$34,080.00

In accordance with the July 2008 Policy, I am requesting you verify the availability of the funds from the Retirement Stabilization Fund, prepare the Council Order, and continue the process in order that my staff can input the information in MUNIS and issue payments to this former employee upon Council approval.

Thank you for your cooperation, and if you should have any questions, please do not hesitate to contact me.

CITY OF SALEM
APPROVAL-SICK DAYS/VACATION BUY-BACK

From: Department _____ School _____ Date 6/24/19

Authorized Signature: [Signature]
Department/Head/City or Business Manager/School

NAME: Catherine Marquardt

CALCULATION

VACATION DAYS # _____ @ \$ _____ = \$ _____
SICK DAYS # 40 @ \$ 408.97 = \$ 16,358.80
PRO-RATED STIPENDS # _____ @ \$ _____ = \$ _____
OTHER # _____ @ \$ _____ = \$ _____

Total Amount Due: \$ 16,358.80
Please attach corresponding PAF or other backup to this sheet.

Reason: Retirement

For Human Resources's Use Only:

- VACATION DAYS
- SICK DAYS
- PER ACCRUAL REPORT
- OTHER

Org and Object: 83113 - 5146

Recommendation:

Approved
[Signature]

[Signature]
H R Director/City or Superintendent/Schools



CITY OF SALEM MASSACHUSETTS

**HUMAN RESOURCES
98 WASHINGTON STREET, 3RD FLOOR
SALEM, MASSACHUSETTS 01970
TEL. 978-619-5630
FAX 978-745-7298**

**KIMBERLEY L. DRISCOLL
MAYOR**

**LISA B. CAMMARATA
DIRECTOR OF HUMAN
RESOURCES**

MEMORANDUM

TO: Laurie Giardella, Director of Finance
DATE: June 28, 2019
RE: Retirement Stabilization Fund

Attached you will find a retirement buy back for a former employee of the Salem Public Schools.

This former employee is contractually entitled to the following amount of sick leave buyback.

Catherine Marquardt

40 sick days @ \$408.97 per day **\$16,358.80**

Total: \$16,358.80

In accordance with the July 2008 Policy, I am requesting you verify the availability of the funds from the Retirement Stabilization Fund, prepare the Council Order, and continue the process in order that my staff can input the information in MUNIS and issue payments to this former employee upon Council approval.

Thank you for your cooperation, and if you should have any questions, please do not hesitate to contact me.



CITY OF SALEM

In City Council,

Ordered:

July 18, 2019

That the sum of Forty-Two Thousand Four Hundred Eight Dollars and Fifty Cents (\$42,408.50) in the "Retirement Stabilization Fund-Vacation/Sick Leave Buyback" account (83113-5146) to be expended for the FY2020 contractual buybacks listed below in accordance with the recommendation of Her Honor the Mayor.

Name	Department	Amount
Martin Butler	Fire Department	\$ 42,408.50

\$ 42,408.50



CITY OF SALEM, MASSACHUSETTS

Kimberley Driscoll
Mayor

July 18, 2019

To the City Council
City Hall
Salem, Massachusetts

Ladies and Gentlemen of the Council:

Enclosed herewith is a request for an appropriation of Forty-Two Thousand Four Hundred Eight Dollars and Fifty Cents (\$42,408.50) from the "Retirement Stabilization Fund-Vacation/Sick Leave Buyback" account (83113-5146) to fund the retirement buyback costs to be expended for the employee listed below.

NAME	DEPARTMENT	AMOUNT
Martin Butler	Salem Fire Department	\$42,408.50
	Total:	<u>\$42,408.50</u>

I recommend passage of the accompanying Order.

Very truly yours,

A handwritten signature in cursive script that reads "Kim Driscoll".

Kimberley Driscoll
Mayor



CITY OF SALEM, MASSACHUSETTS

HUMAN RESOURCES
120 WASHINGTON STREET
TEL. (978) 745-9595 EXT. 5630
FAX (978) 745-7298

KIMBERLEY DRISCOLL
MAYOR

LISA B. CAMMARATA
DIRECTOR OF HUMAN RESOURCES

MEMORANDUM

TO: Laurie Giardella, Director of Finance
DATE: July 11, 2019
RE: Retirement Stabilization Fund

Attached you will find a retirement buy back for a former employee of the Salem Fire Department.

This former employee is entitled to the following amount of vacation and sick leave buyback.

Martin Butler

21 vacation days @ \$323.08 per day (2019)	\$6,784.68
13 vacation days @ \$315.28 per day (2018)	\$4,098.64
82 sick days @ \$369.23 per day	\$30,276.86
94 SMV stipends @\$13.28	\$1,248.32
Total:	\$42,408.50

In accordance with the July 2008 Policy, I am requesting you verify the availability of the funds from the Retirement Stabilization Fund, prepare the Council Order, and continue the process in order that my staff can input the information in MUNIS and issue payments to this former employee upon Council approval.

Thank you for your cooperation, and if you should have any questions, please do not hesitate to contact me.

APPROVAL-SICK DAYS/VACATION BUY-BACK

From: Department Fire

Date 6.27.19

Authorized Signature: [Signature]
Department Head/City or Business Manager/School

NAME: Martin Butler

CALCULATION

✓ 2019 Days
VACATION HOURS # 21 @ \$ 323.08 = \$ 6,784.68
SICK HOURS # 82 @ \$ 369.23 = \$ 30,276.86

PRO-RATED ^{smv} STIPENDS # 94 @ \$ 13.28 = \$ 1,248.32

OTHER ^{2018 vacation days} # 13 @ \$ 323.08 = \$ 4,200.04

315.28 x 13 = 4098.64

Total Amount Due: \$ 42,009.90

Please attach corresponding PAF or other backup to this sheet.

Reason: Retirement [Signature] 7/11/19 Total
[Signature]

42,408.50
[Signature]

For Human Resources's Use Only:

- VACATION HOURS
- SICK HOURS
- PER ACCRUAL REPORT
- OTHER

Org and Object: 83113 - 5146

Recommendation:

Approved

[Signature]
H-R Director/City or Superintendent/Schools



CITY OF SALEM

In City Council,

Ordered:

July 18, 2019

That the sum of Thirty Thousand Dollars (\$30,000.00) is hereby appropriated from the Receipts Reserved funds listed below to the Department of Public Services Burial Account (14112-5383) in accordance with the recommendation of Her Honor the Mayor.

From		To		Amount
2430-4800	R/Res Sale of Lots	14112-5383	DPS Burial	20,000.00
2431-4800	R/Res Sale of Vaults	14112-5383	DPS Burial	10,000.00
Total				30,000.00



CITY OF SALEM, MASSACHUSETTS

Kimberley Driscoll
Mayor

July 18, 2019

To the City Council
City Hall
Salem, Massachusetts

Ladies and Gentleman of the Council:

Enclosed herewith is a request for an appropriation of Thirty Thousand Dollars (\$30,000.00) from the "Receipts Reserved" funds listed below to the Department of Public Services Burial Account (14112-5383).

FROM			TO	AMOUNT
2430-4800	R/Res Sale of Lots	14112-5383	DPS Burial	\$20,000.00
2431-4800	R/Res Sale of Vaults	14112-5383	DPS Burial	\$10,000.00
			Total:	<u>\$30,000.00</u>

This appropriation is necessary to purchase burial boxes for burial services for cemetery.

I recommend passage of the accompanying Order.

Very truly yours,

Kimberley Driscoll
Mayor



KIMBERLEY DRISCOLL
MAYOR

DAVID KNOWLTON P.E.
DIRECTOR OF PUBLIC SERVICES

CITY OF SALEM, MASSACHUSETTS

DEPARTMENT OF PUBLIC SERVICES
5 JEFFERSON AVENUE - FACILITY LOCATION
98 WASHINGTON STREET - MAILING ADDRESS
SALEM, MASSACHUSETTS 01970
TEL. (978) 744-3302
FAX (978) 744-6820
DKNOWLTON@SALEM.COM

July 9, 2019

The Honorable Mayor Kimberly Driscoll
City of Salem
93 Washington Street
Salem, Massachusetts 01970

Subject: Burial Service for Q1FY2020

Dear Mayor Driscoll,

We respectfully request an appropriation of funds in the amount of Thirty Thousand, (\$30,000.00) from the following account:

2430-4800 Sale of Lots	\$20,000.00
2431-4800 Sale of Vaults	\$10,000.00

to be transferred in to the Public Service Burial Services Line 14112-5383. This appropriation will allow for the burial services and operations for the first quarter of Fiscal Year 2020.

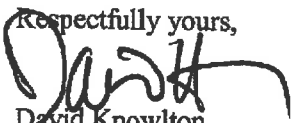
Respectfully yours,

David Knowlton
Director of Public Services

Cc: Laurie Giardella
File Copy

CITY OF SALEM - Finance Department
Free Cash, W & S R/E, R/Res & Budget Transfer Request Form

From: DPS - Cemetery [Signature] 7/9/19
 Department Department Head Authorizing Signature Date

Budget or R/Res Budget Amt: \$ 0
Transfers To: 1412/5383 Desc: Burial Services Balance: 0
(Org/Object)
 From: 2430/4800 Desc: Sale of lots Budget Amt: 0
 Balance: 49,268.00
 (*Note - Please include letter to Mayor for Transfers from different Personnel & Non-personnel lines)
 Current Balance in Receipts Reserved Fund Above (if applicable) - \$ _____ Date: _____

Free Cash or To: _____ Desc: _____ Budget Amt: _____
Retained Earnings (W/S) (Org/Object) Balance: _____
 Please circle one

Amount Requested: \$ 20,000.00
 Reason (Be Specific) funds needed for Burial Services for Cemetery.

For Finance Department and Mayor's Use Only:

_____ Budget Transfer _____ Mayor Approval _____ City Council Approval
 _____ Free Cash Appropriation - City Council Approval - Gen Fund \$ _____
Free Cash Balance
 _____ R/E Appropriation - Water \$ _____ R/E Appropriation Sewer \$ _____
R/E Balance R/E Balance
 _____ Receipts Reserve - City Council Approval \$ _____
R/Res Fund Balance
 _____ Raise & Appropriate _____ Other _____

Recommendation: Approved Denied

 Finance Director

Completed: Date: _____ By: _____ CO # _____ JE#: _____ Transfer #: _____

CITY OF SALEM - Finance Department
Free Cash, W & S R/E, R/Res & Budget Transfer Request Form

From: DPS - Cemetery [Signature] _____
 Department Department Head Authorizing Signature Date

Budget or R/Res Budget Amt: 0
Transfers To: 14112/5383 Desc: Burial services Balance: 0
 (Org/Object)
 From: 2431/4800 Desc: Sale of vaults Budget Amt: 0
 Balance: \$29,476.39
 (*Note - Please include letter to Mayor for Transfers from different Personnel & Non-personnel lines)
 Current Balance in Receipts Reserved Fund Above (if applicable) - \$ _____ Date: _____

Free Cash or To: _____ Desc: _____ Budget Amt: _____
Retained Earnings (W/S) (Org/Object) Balance: _____
 Please circle one

Amount Requested: \$ 10,000.00
Reason (Be Specific) funds needed for Burial Services for cemetery.

For Finance Department and Mayor's Use Only:

_____ Budget Transfer _____ Mayor Approval _____ City Council Approval
 _____ Free Cash Appropriation - City Council Approval - Gen Fund \$ _____
 Free Cash Balance
 _____ R/E Appropriation - Water \$ _____ R/E Appropriation Sewer \$ _____
 R/E Balance R/E Balance
 _____ Receipts Reserve - City Council Approval \$ _____
 R/Res Fund Balance
 _____ Raise & Appropriate _____ Other _____

Recommendation: Approved Denied _____
 Finance Director

Completed: Date: _____ By: _____ CO # _____ JE#: _____ Transfer #: _____



CITY OF SALEM

In City Council,

Ordered:

July 18, 2019

That the sum of Two Thousand Three Hundred Dollars and Twenty-four Cents (\$2,300.24) in the "Retirement Stabilization Fund-Vacation/Sick Leave Buyback" account (83113-5146) to be expended for the FY2020 contractual buybacks listed below in accordance with the recommendation of Her Honor the Mayor.

Name	Department	Amount
Louis Levesque	Department of Public Services	\$ 2,300.24
		\$ 2,300.24



CITY OF SALEM, MASSACHUSETTS

Kimberley Driscoll
Mayor

July 18, 2019

To the City Council
City Hall
Salem, Massachusetts

Ladies and Gentlemen of the Council:

Enclosed herewith is a request for an appropriation of Two Thousand Three Hundred Dollars and Twenty-Four Cents (\$2,300.24) from the "Retirement Stabilization Fund-Vacation/Sick Leave Buyback" account (83113-5146) to fund the retirement buyback costs to be expended for the employee listed below.

NAME	DEPARTMENT	AMOUNT
Louis Levesque	Department of Public Services	\$2,300.24
	Total:	<u>\$2,300.24</u>

I recommend passage of the accompanying Order.

Very truly yours,

Kimberley Driscoll
Mayor



CITY OF SALEM, MASSACHUSETTS

HUMAN RESOURCES
120 WASHINGTON STREET
TEL. (978) 745-9595 EXT. 5630
FAX (978) 745-7298

KIMBERLEY DRISCOLL
MAYOR

LISA B. CAMMARATA
DIRECTOR OF HUMAN RESOURCES

MEMORANDUM

TO: Laurie Giardella, Director of Finance
DATE: June 10, 2019
RE: Retirement Stabilization Fund

Attached you will find a retirement buy back for a former employee of the Department of Public Services.

This former employee is entitled to the following amount of vacation buyback.

Louis Levesque

81,899 vacation hours @ \$28.0863 per hour \$2,300.24

Total: \$2,300.24

In accordance with the July 2008 Policy, I am requesting you verify the availability of the funds from the Retirement Stabilization Fund, prepare the Council Order, and continue the process in order that my staff can input the information in MUNIS and issue payments to this former employee upon Council approval.

Thank you for your cooperation, and if you should have any questions, please do not hesitate to contact me.

LB

**CITY OF SALEM
APPROVAL-SICK DAYS/VACATION BUY-BACK**

From: Department DPS Date 6/4/19

Authorized Signature: David [Signature]
 Department Head/City or Business Manager/School

NAME: Louis Levesque

CALCULATION

VACATION HOURS # 81.8989 @ \$ 28.0863 = \$ 2,300.24

SICK HOURS # _____ @ \$ _____ = \$ _____

PRO-RATED STIPENDS # _____ @ \$ _____ = \$ _____

OTHER # _____ @ \$ _____ = \$ _____

Total Amount Due: \$ _____

Please attach corresponding PAF or other backup to this sheet.

Reason: Retired - 5/31/19

For Human Resources's Use Only:

- VACATION HOURS
- SICK HOURS
- PER ACCRUAL REPORT
- OTHER

Org and Object: 83113 - 5146

Recommendation:
 Approved
[Signature]
 HR Director/City or Superintendent/Schools



CITY OF SALEM

In City Council,

Ordered:

July 18, 2019

To accept the donation of Two Thousand Five Hundred dollars and 00/100 (\$2,500.00) from Tropical Products, Inc.. These funds will be deposited into the Police Donation Fund 2411, account 24111-4830 to be used for National Night Out, in accordance with the recommendation of Her Honor the Mayor.



CITY OF SALEM, MASSACHUSETTS

Kimberley Driscoll
Mayor

July 18, 2019

Honorable Salem City Council
Salem City Hall
Salem, Massachusetts 01970

Ladies and Gentlemen of the City Council:

Enclosed is a request to accept a donation from Tropical Products, Inc. in the amount of Two Thousand Five Hundred dollars and 00/100 (\$2,500.00). These funds will be deposited into the Police Donation Fund 24111-4830.

In order to accept the donation approval must be given by both the Mayor and City Council. I ask that the members of the City Council join with me in accepting these funds to be used towards the Police Donation Fund.

Very truly yours,

Kimberley Driscoll
Kimberley Driscoll
Mayor



City of Salem, Massachusetts Police Department Headquarters

**CHIEF OF POLICE
MARY E. BUTLER**

July 8, 2019

Mayor Kimberley Driscoll
City Hall
93 Washington Street
Salem, MA 01970

Dear Mayor Driscoll:

I would like to request that the enclosed donation from Tropical Products, Inc. in the amount of Two Thousand Five Hundred and 00/100 (\$2,500.00) be deposited into the following revenue fund:

Fund Name:	Police Donation Account
Fund Number:	2411
Org/Object:	24111-4830

The purpose of this donation is to support National Night Out in the City of Salem.

Sincerely,

A handwritten signature in cursive script, appearing to read "Mary E. Butler".

Mary E. Butler
Chief of Police

MEB:jc
Enclosure

TROPICAL PRODUCTS, INC.

42378

REF NO	MEMO	DATE	AMOUNT	PAID
06102019		6/10/19	2,500.00	2,500.00
6/10/19			42378	Salem Police Department
				\$2,500.00

TROPICAL PRODUCTS, INC.
 220 HIGHLAND AVE
 SALEM, MA 01970

SALEM FIVE BANK
 SALEM, MA 01970
 SS-70552113

42378
 DATE: Jun 10, 2019
 AMOUNT

Acct. #:

\$ *****\$2,500.00

PAY TO THE ORDER OF: Two Thousand Five Hundred and 00/100 Dollars

Salem Police Department
 Salem, MA 01970

Renee Dione
 AUTHORIZED SIGNATURE

⑆042378⑆ ⑆211370558⑆ 0899083133⑆



CITY OF SALEM

In City Council,

Ordered:

June 13, 2019

To accept the donation of Two thousand dollars and 00/100 (\$2,000.00) from Footprint Power Salem Harbor Development LP. These funds will be deposited into the K-9 Donation Fund 2412, account 24121-4830 to be used for the care and supplies of three (3) K9 dogs, in accordance with the recommendation of Her Honor the Mayor.



CITY OF SALEM, MASSACHUSETTS

Kimberley Driscoll
Mayor

July 18, 2019

Honorable Salem City Council
Salem City Hall
Salem, Massachusetts 01970

Ladies and Gentlemen of the City Council:

Enclosed is a request to accept a donation from Footprint Power Salem Harbor Development LP in the amount of Two Thousand dollars and 00/100 (\$2,000.00). These funds will be deposited into the K-9 Donation Fund 24121,4830 to be used for the care and supplies of three (3) K-9 dogs.

In order to accept the donation approval must be given by both the Mayor and City Council. I ask that the members of the City Council join with me in accepting these funds to be used towards the Police K-9 Donation Fund.

Very truly yours,

A handwritten signature in cursive script that reads "Kimberley Driscoll".

Kimberley Driscoll
Mayor



City of Salem, Massachusetts Police Department Headquarters

CHIEF OF POLICE
MARY E. BUTLER

June 13, 2019

Mayor Kimberley Driscoll
City Hall
93 Washington Street
Salem, Massachusetts 01970

Dear Mayor Driscoll:

I would like to request that the enclosed donation from **Footprint Power Salem Harbor Development LP** in the amount of Two Thousand and 00/100 Dollars (\$2,000.00) be deposited into the following revenue account for the Salem Police K9.

Fund Name:	K9 Donation Account
Fund Number:	2412
Obj/Orj:	24121-4830

The purpose of this is to support the K9 Donation Account for the care and supplies of three (3) K9 Dogs.

Sincerely,

Captain Conrad Prosniewski, Acting Chief of Police

CP:jc
Enclosure

THIS DOCUMENT HAS A COLORED SECURITY BACKGROUND. DO NOT CASH IF THE WORD VOID IS VISIBLE. THIS PAPER HAS AN ARTIFICIAL WATERMARK ON REVERSE SIDE AND IS ALTERATION PROTECTED.

FOOTPRINT POWER SALEM HARBOR DEVELOPMENT LP

24 FORT AVENUE
SALEM, MA 01970



Wells Fargo Bank, N.A.

101472
11-24/1210

*TWO THOUSAND AND XX / 100

ISSUE DATE	CHECK NUMBER	AMOUNT
6/7/2019	101472	*****2,000.00*

PAY TO THE ORDER OF
 City of Salem
 Salem Police Department
 Salem Police K9
 95 Margin St.
 Salem, MA 01970

Michael P. King

⑆ 101472⑆ ⑆ 121000248⑆ ⑆ 4128095351⑆

FOOTPRINT POWER SALEM HARBOR DEVELOPMENT LP

101472

Date	Invoice Number	Comment	Amount	Discount Amount	Net Amount
5/31/2019	05312019	K9 UNIT COMMUNITY DONATION	2,000.00	0.00	2,000.00
	900030-05-01	Non CBA Community Donations:Unit 5-Fixed		1,000.00	1,000.00
	900030-06-01	Non CBA Community Donations:Unit 6-Fixed		1,000.00	1,000.00

Check: 101472 6/7/2019 City of Salem Check Total: 2,000.00



CITY OF SALEM

In City Council, July 18, 2019

Ordered:

That a petition to the General Court, accompanied by a bill authorizing the City of Salem to convert a license for the sale of wine and malt beverages to be drunk on the premises to a license for the sale of all alcohol to be drunk on the premises as set forth below, be filed with an attested copy of this Order be, and hereby is, approved under Clause (1) of Section 8 of Article 2, as amended, of the Amendments to the Constitution of the Commonwealth of Massachusetts, to the end that the following legislation be adopted, except for amendments by the Senate or House of Representatives which conform to intent of this home rule petition:

AN ACT AUTHORIZING THE CITY OF SALEM TO CONVERT A LICENSE FOR THE SALE OF WINE AND MALT BEVERAGES TO BE DRUNK ON THE PREMISES TO A LICENSE FOR THE SALE OF ALL ALCOHOLIC BEVERAGES TO BE DRUNK ON THE PREMISES

Be it enacted by the Senate and House of Representatives in General Court assembled, and by the authority of the same as follows:

SECTION 1. (a) Notwithstanding section 17 of chapter 138 of the General Laws, the licensing authority of the city of Salem may convert the annual license for the sale of wines and malt beverages to be drunk on the premises pursuant to section 12 of said chapter 138, originally issued to Polonia Restaurant Group pursuant to section 7 of chapter 149 of the acts of 2011 and currently issued to Blue Fez Inc. d/b/a Blue Fez at 118 Washington street, Unit C, to an annual license for the sale of all alcoholic beverages to be drunk on the premises pursuant to said section 12 of said chapter 138 to Blue Fez Inc. d/b/a Blue Fez at 118 Washington street, Unit C. The license converted pursuant to this section shall be subject to all of said chapter 138, except said section 17.

(b) The licensing authority shall not approve the transfer of the license converted pursuant to this section to any other location but it may grant the license to a new applicant at the same location if the applicant for the license files with the licensing authority a letter from the department of revenue and a letter from the department of unemployment assistance indicating that the license is in good standing with those departments and that all applicable taxes, fees and contributions have been paid.

(c) If the license converted pursuant to this section is cancelled, revoked or no longer in use at the location of original issuance, it shall be returned physically, with all of the legal rights, privileges and restrictions pertaining thereto, to the licensing authority and the licensing authority may then grant the license to a new applicant at the same location under the same conditions as specified in this section.

SECTION 2. (a) The city of Salem shall charge a fee for the conversion to a license for the sale of all alcoholic beverages to be drunk on the premises pursuant to this act that shall be paid by the licensee at the time of issuance unless the licensing authority agrees to enter into an arrangement with the licensee which would enable the fee to be divided into multiple payments or prorated over multiple periods of time. If the city elects to accept prorated payments over time from the licensee, the option shall be made available, upon request, to all qualified applicants for licensure.

(b) Any fee collected by the city of Salem for a license converted or granted pursuant to this act that is greater than the amount of the fee charged for an annual renewal of a similar license issued by the city shall be deposited into an economic development account which has been established by the city of Salem and expended by it in a manner consistent with the purposes of the account.

SECTION 3. This act shall take effect upon its passage.



CITY OF SALEM, MASSACHUSETTS

Kimberley Driscoll
Mayor

Office of the Mayor

July 18, 2019

Salem City Council
City Hall
93 Washington Street
Salem, MA 01970

Ladies and Gentlemen of the City Council:

The enclosed Order submits a special act to the legislature to convert the annual wine and malt beverages license held by the Blue Fez restaurant on Lappin Park to an annual all alcohol license.

Since it opened, Blue Fez has helped enliven our downtown restaurant scene with more diverse cuisine and fare. A wine and malt beverage license is limiting to their business however, and so they have agreed to apply and pay the required fees to seek a special act to convert their license.

I hope you will support this Order to send this petition to the legislature as quickly as possible, so that the sometimes-lengthy state-level process may get underway as soon as feasible.

Very truly yours,

Kimberley Driscoll
Mayor
City of Salem

CC: State Rep. Paul Tucker
State Sen. Joan Lovely



**CITY OF SALEM
APPLICATION FOR SPECIAL ACT LIQUOR LICENSE**

INDICATE TYPE OF LICENSE: WINE AND MALT RESTAURANT ALL ALCOHOL RESTAURANT
 WINE AND MALT PACKAGE STORE
 ALL ALCOHOL PACKAGE STORE
 CONVERSION Seasonal to Annual Beer and Wine
to Annual All Alcohol

Corporation Name (If applicable, see Q1): <u>Blue Fez, Inc</u>	Business Name (D/B/A): <u>Blue Fez</u>
APPLICANT(S) (Sole proprietor): <u>Abdennaccour Belghiti</u>	Physical Location: <u>118 Washington St.</u>
Address: <u>56 Pebble Ave</u>	Mailing Address (If different than location):
City/Town: <u>Winthrop</u> State: <u>MA</u> Zip Code: <u>02152</u>	City: <u>Salem</u> State: <u>MA</u> Zip Code: <u>01970</u>
Telephone Number: <u>(617) 966-0684</u> Fax Number: <u>N/A</u>	Business Telephone Number: <u>(978) 744-2700</u> Fax Number: <u>N/A</u>
Tax I.D. #: <u>83-1472021</u>	
Email Address: Please Print <u>nasser.belghiti@verizon.net</u>	Website: <u>bluefezrestaurant@gmail.com</u>

1. Is applicant a corporation, limited liability company or limited partnership? YES NO
If Yes, please complete the Corporate Information required for Business Entities who are licensees.

2. Is the physical location of the business leased or owned? Leased
Provide copy of deed or lease.

3. Is the business new or existing? Please describe.
Existing restaurant

4. Do you have experience managing a business with a liquor license? Please describe.
Yes I am managing a business/restaurant, namely Kasbah Restaurant, located in Winthrop, MA, with a liquor license.

ON PREMISE DIAGRAM

In an effort to clearly define your license premise and the area that consumption and storage of liquor is allowed, all applicants for on-premise consumption of alcohol must submit a diagram of the premise to be licensed in addition to a completed license application.

Diagrams should be submitted on this form and should be as accurate as possible. Be sure to label the areas of your diagram including entrances, office area, kitchen, storage areas, dining rooms, lounges, function rooms, restrooms, decks and all areas that you are requesting approval for liquor consumption.

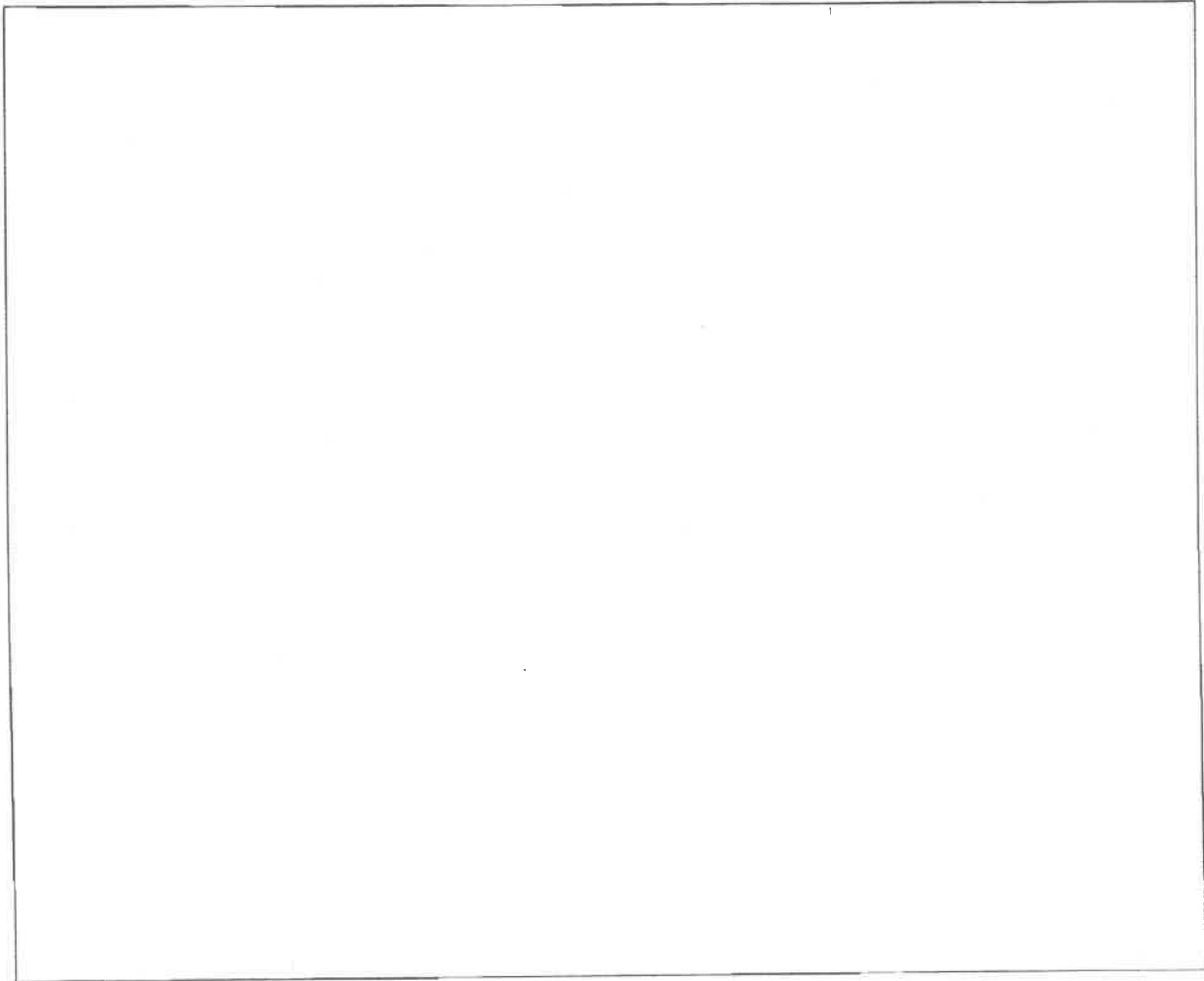

5. Do you own or have any interest in any another MA Liquor License? Yes No
If yes, please provide Name and physical location of any other MA Liquor Licenses.

6. Do you/will you permit dancing or entertainment on the licensed premises? YES NO
If yes, please describe type, days and time of entertainment.

7. Is/are applicants(s) and manager citizens of the United States? YES NO
(Requirement of MA ABCC)

8. Describe in detail the premises to be licensed including any outdoor space where alcohol may be consumed: (On Premise Consumption Requires Diagram – See attached)

Please see attached Lease Agreement (diagram attached)

9. Do you have all the necessary permits required by the Board of Health, Fire Dept and Building Inspector?

HEALTH: YES NO Applied for: _____

BLDG.: YES NO Applied for: _____

FIRE.: YES NO Applied for: _____

Please provide any further information regarding the application below.

Signature of Applicant or Corporate Officer(s)

Signature of Applicant or Corporate Officer(s)

Print Name

Print Name

**Corporate Information Required for
Business Entities Who Are Licensees**

Responses to questions below must match information on file with the MA Secretary of State's office.

1. Exact legal name: Blue Fez, Inc.

2. Doing Business As, if any: Blue Fez

3. Date of filing with Secretary of State: 8/16/18 State in which you are formed: MA

4. If not a MA business entity, date on which you were authorized to transact business in the State of MA

5. List the name, addresses and title of officers, directors and list the percentage ownership: (attach additional sheets as needed)

NAME	ADDRESS	TITLE	% OWNERSHIP
Abdennaceur Belghiti	56 Pebble Ave. Winthrop, MA 02152	President	100 %
Abdennaceur Belghiti	56 Pebble Ave. Winthrop, MA 02152	Treasurer	100 %
Abdennaceur Belghiti	56 Pebble Ave. Winthrop, MA 02152	Secretary	100 %
Abdennaceur Belghiti	56 Pebble Ave Winthrop, MA 02152	Director	100 %

(Stock ownership in non-publicly traded companies must add up to 100%.)

Signature:

Signature of Duly Authorized Person

Date



CITY OF SALEM

In City Council, July 18, 2019

Ordered: In accordance with 760 CMR 66.08, the Mayor, on behalf of the City of Salem, is hereby authorized to submit to the Massachusetts Department of Housing and Community Development (DHCD) an amendment to the existing Downtown Salem Housing Development (DH) Zone and Housing Development Incentive Program Plan originally approved by DHCD in 2017 and amended in 2018. The HD Zone shall be expanded to include all parcels in the City.



CITY OF SALEM, MASSACHUSETTS

Kimberley Driscoll
Mayor

Office of the Mayor

July 18, 2019

Salem City Council
City Hall
93 Washington Street
Salem, MA 01970

Ladies and Gentlemen of the City Council:

The enclosed Order extends the City's existing Housing Development Incentive Program (HDIP) zone from the B5, NRCC, and three specific parcels, to all districts in the City.

As you know, HDIP is a tool that allows residential builders to seek a Tax Increment Exemption, which is similar to a commercial Tax Increment Finance (TIF) agreement. A property owner in the HDIP zone with a qualifying residential project can apply to the City Council for consideration of a TIE, which provides a partial reduction in their tax obligation for a set amount of time. As with a TIF, this reduction only applies to the *new value* of the project. The City will never collect less than the base value of the property and, after the TIE concludes, it will collect the full tax obligation on the improved property.

TIEs are important tools that can make the difference between an abandoned brownfield or vacant building being left in a neighborhood and an improved, clean, and productive home for Salem residents. Because every single TIE application must be approved first by the City Council, there is a powerful backstop to ensure projects meet the Council and our community's standards. You can read more about HDIP at <https://www.mass.gov/service-details/housing-development-incentive-program-hdip>.

We view this measure as one more tool in our housing toolbox. All of these proposals, including this one, are intended to lower the cost to rent or buy a home here in Salem by expanding the diversity and supply of housing for our families, seniors, and workers. I strongly recommend adoption of this Order.

Very truly yours,

Kimberley Driscoll
Mayor
City of Salem



CITY OF SALEM, MASSACHUSETTS
HOUSING DEVELOPMENT INCENTIVE PROGRAM
HDIP ZONE AMENDMENT PROPOSAL

The City would like to expand and rename the existing Downtown Salem HD Zone. Below is a memo summarizing the change in accordance to 760 CMR 66.08.

1. Detailed description of each proposed change

In accordance with 760 CMR 66.08, the City of Salem would like to expand and rename its existing Downtown Salem HD Zone approved by DHCD in 2017 and amended in 2019. The expansion would include all parcels within the City of Salem and the would be renamed, "Salem HD Zone."

2. The purpose of the change – i.e., the reason why each change is needed

The need for multifamily housing extends beyond the current HD Zone. New requests are being made as developers explore opportunities to produce more housing. The expansion of the HD Zone will increase market rate residential development in the city on sites suitable for mixed-use, multifamily development by providing an additional financing tool to overcome development challenges, as well as increase the feasibility of market rate housing projects. Expanding the zone to include all parcels in the city does not necessarily guarantee that all housing projects will participate in the HDIP but provides a tool for development should developers want to collaborate with the City and DHCD.

The objective of the HD Plan and the amendment to expand the zone is to foster appropriately scaled residential development throughout the city. The proposed expansion is consistent with objectives in the *Salem Housing Needs and Demand Analysis* and will assist in meeting projected housing needs. The SHNADA opens by noting, "Creating homes for the next generation of workers while also addressing the complex needs of an aging and increasingly diverse population is one of those challenges (SHNADA Introduction, p. 7)."

The cost of redevelopment in Salem is high considering prior uses that frequently have environmental issues, sites with challenging elevations or ledge, and significant wetland areas.

The expansion of the HD Zone would afford developers an additional incentive to overcome high redevelopment costs.

3. The effect of each change on individual HD Projects

This proposal will not have an effect on the parcels currently in Salem's HD Zone. The only approved HD project is 65 Washington Street. The project is progressing in large part because of the City's initial adoption of the HD Plan and Zone. Other projects are in the conceptual or pre-development phase and are contemplating utilizing the HDIP.

4. Pertinent revisions of the original Application for approval of the HD Zone designation or HD Zone Plan, or to the HD Tax Increment Exemption Agreement, to reflect the changes

The City is not proposing any amendments to the HD Zone Plan that would affect the existing HD Tax Increment Exemption Agreement. The timelines for the implementation of the HD Zone Plan and the duration of the HD Zone Plan as laid out in the City's current approved plan will remain unchanged.

5. A statement of whether the Municipality considers the amendment to be material or nonmaterial

The City of Salem considers the proposed amendment to be material.

6. Evidence of a public hearing, as appropriate, including a copy of hearing notices and minutes

The Department of Planning and Community Development intends to submit the amendment plan to the City Council in July 2019. The City Council will then hold a public hearing. A copy of the hearing notice and minutes will be provided to DHCD. DHCD has already advised of this proposed amendment.

7. Certification by the Town or City Clerk of local approval pursuant to 760 CMR 66.08 (3)

The City will provide DCHCD with a certification from the City Clerk once the amendment plan has been approved by the City Council.



CITY OF SALEM

In City Council, July 18, 2019

Ordered:

The Salem City Council hereby authorizes, subject to the approval of the Salem Traffic and Parking Commission, the use by Stella's Restaurant and Wine Bar of two metered parking spaces at 94 Lafayette Street on a temporary, trial basis for a period not to exceed four months. The spaces may be used by Stella's on Friday and Saturday evenings from 4 to 11 pm for a valet services. In addition, the valet, operated and paid for by Stella's, may also utilize spaces set aside at Riley Plaza for the City's trial valet service on Washington Street.



CITY OF SALEM, MASSACHUSETTS

Kimberley Driscoll
Mayor

Office of the Mayor

July 18, 2019

Salem City Council
City Hall
93 Washington Street
Salem, MA 01970

Ladies and Gentlemen of the City Council:

The enclosed Order authorizes the use of two parking spaces on Lafayette Street near Stella's Wine Bar for the restaurant to provide valet parking services through November 18, 2019 on Friday and Saturdays from 4:00 p.m. to 11:00 p.m., conditional upon their also receiving approval from the Traffic and Parking Commission later this month.

As you know, this location has been home to a number of previous restaurants. We have routinely heard that parking is one of the greatest challenges to a restaurant succeeding here. The availability of these two spaces, primarily at hours during which the City would not be collecting any parking meter revenues from them anyway, could make a significant difference the ability of this small business to serve their customers and, therefore, succeed.

Very truly yours,

Kimberley Driscoll
Mayor
City of Salem

City Council
City of Salem
Washington St
Salem, MA 01970

RE: Valet Parking – Lafayette St

Dear City Council:

Since the inception of Stella's Restaurant, we have been faced with several challenges, the largest challenge being parking.

Potential guests drive past Stella's and keep going as there is no street parking available.

By offering valet services on Friday & Saturday nights, Stella's should greatly benefit. However, we would require the 2 parking spaces located directly in front of Stella's be blocked off on those nights (from 4pm – 11pm). As well as blocking off spaces for the valet in one of the public lots nearby.

I would welcome any type of pilot valet program, similar to what is taking place on Washington St. We are happy to hire our own valet company.

I hope you will consider granting us permission, and hopefully we can get them implemented as soon as possible.

Please call with me personally with any questions, I can be reached at 617.839.4117.

Warmest regards,

Peter Mikedis



STELLA'S
RESTAURANT AND WINE BAR

CITY OF SALEM

In the year Two Thousand and Nineteen

An Ordinance to amend an Ordinance relative to Traffic,

Be it Ordained by the City Council of the City of Salem, as follows:

SECTION 1. Amending Chapter 42 Section 10 – “One-way Streets”

By repealing the following:

Beaver Street – from where the easterly end of Silver Street intersects with Beaver Street, thence easterly to the easterly end of the property line of No. 17 Beaver Street.

And retaining the following:

Beaver Street – from where the easterly end of Silver Street intersects with Beaver Street thence easterly to Grove Street. (1/8/78 DPW 5-1498)

SECTION 2. Amending Chapter 42 Section 51 – “Parking Prohibited on Certain Streets”

By repealing the following:

Beaver Street – Parking prohibited on certain streets southerly side.

And replacing it with the following:

Beaver Street – Parking prohibited on certain streets southerly side, from Safford Street extending easterly to a point approximately 70 ft from the intersection with Grove Street.

SECTION 3. This ordinance shall take effect as provided by City Charter

In City Council June 27, 2019

Motion to table until next meeting on July 18, 2019 ⇨ Voted

In City Council July 18, 2019



CITY OF SALEM

In City Council, July 18, 2019

Ordered:

The City of Salem hereby accepts, effective Fiscal Year 2020, Massachusetts General Law Chapter 44, Section 53F½ for the purpose of establishing an enterprise fund to account for monies received and spent for cable television public, educational and governmental (PEG) access facilities and operations.

ELIZABETH M. RENNARD

CITY SOLICITOR

93 WASHINGTON STREET

SALEM, MA 01970

TEL: 978.619.5633

FAX: 978.744.1279

EMAIL: BRENNARD@SALEM.COM



CITY OF SALEM

KIMBERLEY L. DRISCOLL, MAYOR

LEGAL DEPARTMENT

93 WASHINGTON STREET

SALEM, MASSACHUSETTS 01970

VICTORIA B. CALDWELL

ASSISTANT CITY SOLICITOR

93 WASHINGTON STREET

SALEM, MA 01970

TEL: 978.619.5634

FAX: 978.744.1279

EMAIL: VCALDWELL@SALEM.COM

July 18, 2019

Salem City Council

City Hall

Salem, MA

Ladies and Gentlemen of the Council:

Enclosed herewith is a proposed Order accepting, effective this fiscal year, Massachusetts General Law Chapter 44, Section 53F½ for the purpose of establishing an enterprise fund to account for monies received and spent for cable television public, educational and governmental (PEG) access facilities and operations.

Effective this year, the Massachusetts Department of Revenue (DOR) is requiring all municipalities to accept and account for monies collected by cable companies for the operation of public access television stations. In the City's case, these are monies collected from Comcast subscribers to fund Salem Access Television and other associated costs.

Establishing an enterprise fund will enable the City to separately account for these PEG funds as required by DOR. Thank you for your consideration of this request. Please contact me if you have any questions.

Sincerely,

Elizabeth Rennard



CITY OF SALEM

In City Council, July 18, 2019

Ordered:

That a petition to the General Court, accompanied by a bill authorizing the Salem Scholarship and Education Committee to provide scholarships from funds collected for educational purposes as set forth below, be filed with an attested copy of this Order be, and hereby is, approved under Clause (1) of Section 8 of Article 2, as amended, of the Amendments to the Constitution of the Commonwealth of Massachusetts, to the end that the following legislation be adopted, except for amendments by the Senate or House of Representatives which conform to intent of this home rule petition:

AN ACT AUTHORIZING THE SALEM SCHOLARSHIP AND EDUCATION COMMITTEE TO PROVIDE SCHOLARSHIPS FROM FUNDS SET ASIDE FOR EDUCATIONAL PURPOSES

Be it enacted by the Senate and House of Representatives in General Court assembled, and by the authority of the same as follows:

SECTION 1. Notwithstanding Chapter 194 of the Acts of 1986, Section 3C of Massachusetts General Law Chapter 60, or any other law to the contrary, the City of Salem Scholarship and Education Committee may provide educational financial aid to deserving Salem residents from educational funds collected, pursuant to Section 3C of Chapter 60, for the purpose of supplementing educational funding and adult literacy programs.

SECTION 2. This act shall take effect upon its passage.



CITY OF SALEM, MASSACHUSETTS

Kimberley Driscoll
Mayor

Scholarship & Education Committee

July 18, 2019

Salem City Council
City Hall
93 Washington Street
Salem, MA 01970

Ladies and Gentlemen of the Council:

Enclosed please find a home rule petition requested by the members of the Scholarship and Education Committee. The statute that originally established the committee also approved its two funds, the Scholarship Fund and the Education Fund. The principle activity of the committee since it was created in 1987 has been to award scholarships to Salem students moving on to higher education. Since 2003 the committee has awarded around \$80,000 in such scholarships, all funded through generous donations by Salem taxpayers and residents.

Because the original statute established two funds, however, donations made to the Education Fund have not been able to be used by the committee for scholarship awards. This special act would remedy that, enabling the committee to make better use of those donations in order to support their efforts to help more Salem families manage the rapidly increasing cost of college.

If you have questions about this request or the special act, please feel free to reach out to Tyler Carlton, chair of the Scholarship and Education Committee, at tcarlton@salem.com.

Sincerely,

Dominick Pangallo
Chief of Staff
Office of Mayor Kimberley Driscoll

CC: State Rep. Paul Tucker
State Sen. Joan Lovely



Comcast
David R. Flewelling
Specialist 2 Construction
9 Forbes Road, Suite 9B
Woburn, MA 01801
Cell – 617-279-7864
dave_flewelling@comcast.com

July 5, 2019

Ms. Ilene Simons
Salem City Clerk
City Hall
93 Washington Street
Salem, MA 01970

RE: 127 Essex Street Salem
Grant of Location-Petition

Dear Ms. Simons:

Enclosed please find materials supporting Comcast request for a grant of location from the Salem City Council. The work associated with the attached petition is for the purpose of installing new underground conduit and manhole. To be used to provide the Comcast service to 127 Essex Street.. For a detailed description of the work please refer to the attached construction sketch.

I look forward to the opportunity to address this matter in further detail at the next Salem City Council Meeting. Should you have any questions or concerns, please feel free to contact me at (617) 279-7864.

Sincerely,

A handwritten signature in black ink that reads "David R. Flewelling". The signature is stylized and written in cursive.

David R. Flewelling
Comcast
Specialist 2, Construction

Enclosure (3)

PETITION OF COMCAST FOR LOCACTION FOR CONDUITS, MANHOLES AND POLES

To the City Council for the City of Salem, Massachusetts:

Respectfully represents Comcast Cable Communications Management LLC., a company incorporated for the distribution of telecommunications services, that it desires to construct a line for such telecommunications under the public way or ways hereinafter specified.

Essex Street: Excavating to place (1) 3'x3' manhole over the existing conduit and excavating to place (1) 4" PVC Conduit 13'+/_ to number 127 Essex Street.

Wherefore, your petition prays that, after due notice and hearing as provided by law, the City Council may by Order grant your petitioner permission to construct, and a location for, such a line of conduits, manholes and poles with the necessary wires and cables therein, said conduits manholes and poles to be located, substantially as shown on the plan made by Comcast dated July 2, 2019 and filed here with, under the following public way or ways of said City of Salem.

Comcast

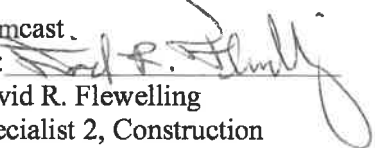
By: 
David R. Flewelling
Specialist 2, Construction

Dated this July 2, 2019

City of Salem Massachusetts

Received and filed _____, 2019

ORDER FOR CONDUIT & POLE LOCATION

In the City Council for the City of Salem, Massachusetts.

ORDERED:

That permission be and hereby is granted to Comcast Cable Communications Management LCC., to lay and maintain underground conduits, manholes and poles, with the wires and cables to be placed therein, under and above the surface of the following public way or ways as requested in petition of said Company dated June 7, 2019

Essex Street: Excavating to place (1) 3'x3' manhole over the existing conduit and excavating to place (1) 4" PVC Conduit 13'+/_ to number 127 Essex Street.

Substantially as shown on plan, filed with said petition.

Also that permission be and hereby is granted said Comcast to lay and maintain underground conduits, manholes, cables and wires in the above or intersecting public ways for the purpose of making connections with such poles and buildings as it may desire for distributing purposes.

The foregoing permission is subject to the following conditions:

1. The conduits and manholes shall be of such materials and construction and all work done in such manner as to be satisfactory to the City Council or to such officers as it may appoint to the supervision of the work.
2. Said Company shall indemnify and save the City harmless against all damages, costs and expense whatsoever to which the City may be subjected in consequence of the acts or neglect of said Company, its agents or servants, or in any manner arising from the rights and privileges granted it by the City.
3. In addition said Company shall, before a public way is disturbed for the laying of its wire or conduits, execute its bond in a penal sum of One Hundred Thousand Dollars (\$100,000) (reference being had to the bond already on file with said City) conditioned for the faithful performance of its duties under this permit.
4. Said Company shall comply with the requirements of existing by-laws and such as may hereafter be adopted governing the construction and maintenance of conduits and wires, so far as the same are not inconsistent with the laws of the Commonwealth.

I hereby certify that the foregoing order was adopted at a meeting of the City Council for the City of Salem, Massachusetts, held on the _____ day of _____ 2019.

(over)

City Clerk

N



CONCRETE SIDEWALK
AS SHOWN
AND REPAIRED PER CITY
OF SALEM DPW & ENGINEERING
STANDARDS

ESSEX INSTITUTE
132-134 ESSEX STREET
PARCEL ID: 35-0214-0

PROPOSED COMCAST 3"x3" MANHOLE
(See Detail - Sheet 2)
OVER EXISTING COMCAST CONDUIT.
CONTRACTOR SHALL TAKE CAREFUL
STEPS EXCAVATING WITHIN THIS AREA DUE
TO THE CLOSE PROXIMITY OF EXISTING
UTILITY MANHOLES AS NOTED
TO AVOID THESE UTILITIES.

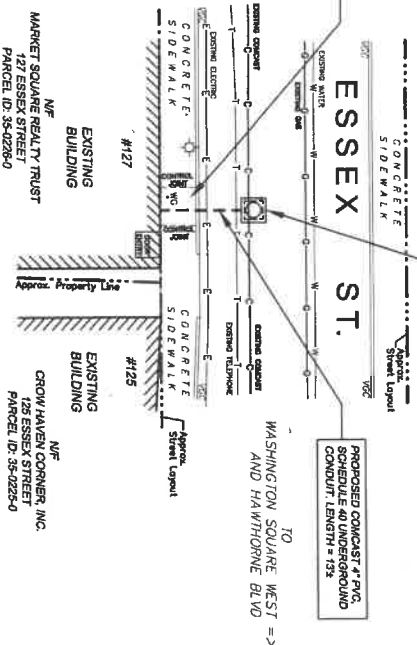

MARKET SQUARE REALTY TRUST
127 ESSEX STREET
PARCEL ID: 35-0226-0

CROW HAVEN CORNER, INC.
125 ESSEX STREET
PARCEL ID: 35-0225-0

GENERAL LEGEND

- SMH SEWER MANHOLE
- WG WATER GATE
- DMH DRAIN MANHOLE
- GG GAS GATE
- EMH ELECTRIC MANHOLE
- CUP UTILITY POLE
- CB CATCH BASIN
- VERT. GRANITE CURB
- C COMCAST UNDERGROUND CABLE
- OHW OVERHEAD WIRES
- G GAS LINE
- W WATER LINE
- S SEWER LINE
- E UNDERGROUND ELECTRIC LINE
- T UNDERGROUND TELEPHONE
- PROPOSED COMCAST UNDERGROUND CONDUITS

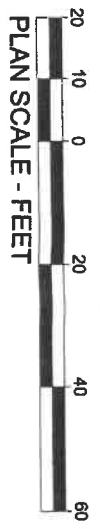

Frederick M. DewSNAP

NOTES:

1. This plan was prepared from record data on file at the City of Salem, the Essex South Registry of Deeds, and a field location tape survey performed by this office on June 14, 2019.
2. The locations of underground utilities as shown are based on above ground structures and record drawings, if any, provided to the Surveyor. The locations of underground utilities/structures may vary from location hereon and are not warranted to be accurate and/or correct. Additional buried utilities/structures may be encountered. No excavations were performed during the progress of this survey to locate buried utilities/structures.
3. Prior to any construction the Contractor shall notify DIG-SAFE at least 72 hours in advance at 811 (National Call Number) for verification of utilities and for field locations.
4. It is the responsibility of the Utility Contractor installing the Comcast underground conduit to notify those utility companies not associated with the DIG-SAFE system to verify the locations of their respective utilities. Also, the installing contractor shall be responsible for repairing or replacing any traffic signal loops damaged during the installation of the new Comcast underground conduit.
5. All work to be performed is the installation of a Comcast 4" PVC, Sch. 40 underground conduit and a 3"x3" manhole to service #127 Essex Street.
6. All work shall conform to the approving authorities Engineering and DPW Standards.
7. Upon completion of the trench work for the day, the contractor shall backfill, compact and pave the trench and the work area shall be broom swept clean. In grassed areas the trench shall be loamed and seeded and hay mulch spread to keep the area stabilized until the grass has taken hold.
8. Street/Property lines are not the result of a boundary survey and are considered to be approximate.

CONSTRUCTION NOTES:

1. Following the Dig-Safe "mark out" and field verification of the existing underground utilities, the Proposed 4" PVC, Sch. 40 Comcast Conduit and Proposed 3"x3" manhole shall be adjusted in the field by the utility contractor to avoid being located over any existing utilities.

PROPOSED COMCAST UNDERGROUND	
ESSEX COUNTY	
PLAN OF LAND	
IN	
SALEM, MA	
Prepared for: COMCAST 9 PROGRESS ROAD, SUITE #8 WOBBURN, MA 01801	Prepared BY: DEWSNAP ENGINEERING ASSOC. LLP 170 Lincoln Avenue - Saugus, MA 01906 Tel. #:(781) 233-0595
Date: JULY 2, 2019	Scale: As Shown
Checked By: F.D.D. & P.A.D.	PROJECT LOCATION: 127 ESSEX STREET
Drawn By: P.A.D.	WARD 1, PRECINCT 1
Field By: P.A.D. & P.P.D.	
Sheet No. 1 of 2	

MANHOLE 3'-X-3' X 2'-6"

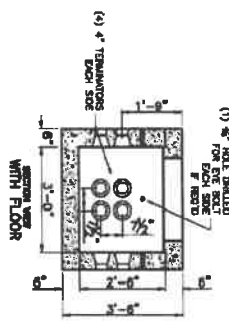
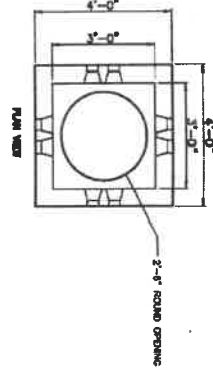

NOTES:

1. CONCRETE SHALL BE PLACED IN PLACE.
2. ALL DIMENSIONS SHALL BE AS SHOWN UNLESS OTHERWISE NOTED.
3. ALL MATERIALS SHALL BE AS PER THE CITY/TOWN/STATE DPW STANDARDS.
4. ALL MATERIALS SHALL BE AS PER THE CITY/TOWN/STATE DPW STANDARDS.

PROJECT NO.	MH-333	DATE	MH 3/3/2-6	SCALE	I.C.1
CLIENT	4500	DATE	2/5/2018	SCALE	
PROJECT	L.P.	DATE		SCALE	
PROJECT	775 State Street, Suite 1100, Worcester, MA 01608	DATE		SCALE	

DETAIL NOTES:

The details depicted are for general reference only. The final product used shall be the responsibility of the general contractor and shall be of equal or greater material than that depicted and shall conform to the Engineering/DPW Standards for the division within the project is located.

EAST JORDAN IRON WORKS - FRAME & COVER DETAIL
 NOT TO SCALE

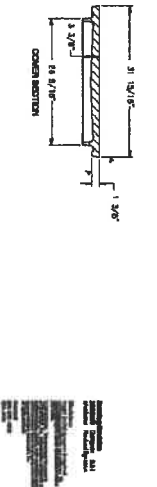
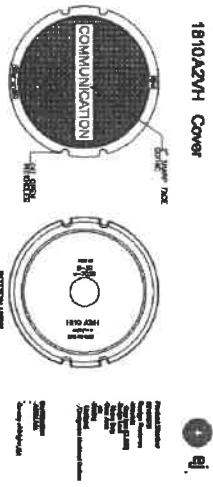
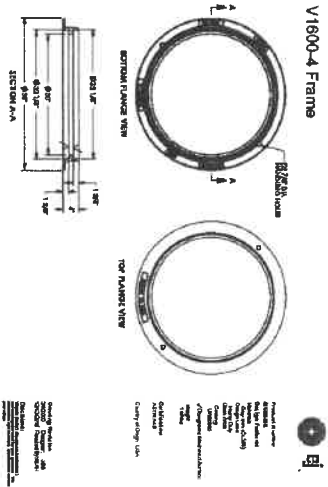

NOT TO SCALE

V1800-A Frames

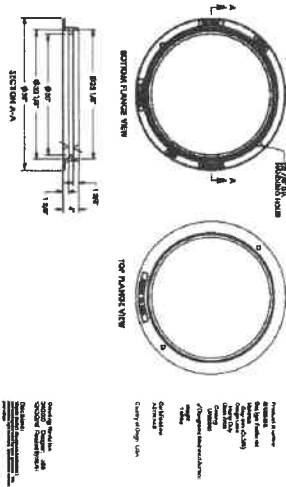

PROPOSED COMCAST UNDERGROUND
ESSEX COUNTY
 PLAN OF LAND
 IN
SALEM, MA

"D E T A I L S"
 NOT TO SCALE

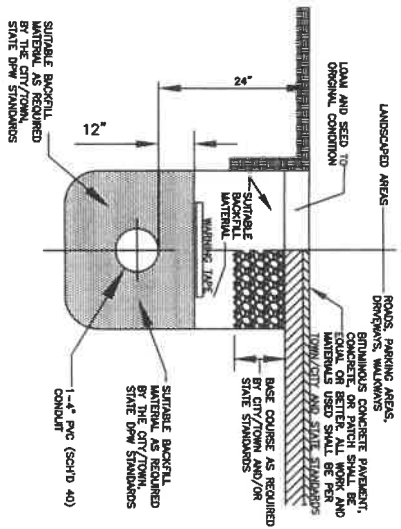

Prepared for:	COMCAST 9 FORBES ROAD SUITE 88 WOBURN, MA 01801	Prepared by:	DEWSNAP ENGINEERING ASSOC. LLP 178 Lincoln Avenue - Saugus, MA 01906 Tel: # (781) 233-0595
Date:	JULY 2, 2019	Scale:	As Shown
Checked By:	F.D.D. & P.A.D.	PROJECT LOCATION:	127 ESSEX STREET WARD 1, PRECINCT 1
Drawn By:	P.A.D.		
Field By:	P.A.D. & A.P.D.		
	Sheet No. 2 of 2		

Federick DeVSNAP, Jr.

City of Salem

In the year two thousand nineteen

An Ordinance to amend the zoning ordinance by adding “Municipal and Religious Building Reuse” as a use permitted in certain zoning districts upon the issuance of a special permit by the Planning Board subject to the requirements of new section 6.11 of the zoning ordinance.

Be it ordained by the City Council of the City of Salem, as follows:

Section 1. Section 3.1 Table of Principal and Accessory Use Regulations of the City of Salem Zoning Ordinance (the “Zoning Ordinance”) is hereby amended by adding the following principal use under “B. Exempt and Institutional Uses”:

	R C	R 1	R 2	R 3	B 1	B 2	B 4	B 5	I	B P D	N R C C
Municipal or Religious Building Reuse**	P B	P B	P B	P B	n	n	n	n	n	n	n

** Subject to Section 6.11.

Section 2. Section 6 - Special Regulations of the Zoning Ordinance is hereby amended by adding the following new section:

6.11 Municipal or Religious Reuse Special Permit

6.11.1 Purpose.

The purpose of this Section 6.11 is to allow for the reuse of buildings in municipal or religious use into new uses that may not otherwise be allowed on those properties so as to promote historic preservation, economic development, housing production and environmental sustainability and resilience.

6.11.2 General

A Building in municipal or religious use may be converted to one or more of the uses set forth in Section 6.11.5 upon the issuance of a special permit by the Planning Board authorizing that new use or uses. The special permit shall apply only to the Building and not to any structural extensions or alterations other than those allowed under 6.11.4. If the petitioner meets the requirements of this Section 6.11, the Planning Board may approve, or approve with conditions, an application for such special permit.

6.11.3 Eligibility for Special Permit

One or more Buildings in municipal use or religious use shall be eligible for a special permit under Section 6.11 where:

1. the Building(s) in municipal or religious use and for which a change of use is proposed is at least 4,000 square feet;
2. one or more of the Building(s) in municipal or religious use and for which a change of use is proposed to a Building at least fifty (50) years old at the time of application under this Section 6.11 and
3. the applicant seeks to change the use of the Building from municipal or religious use to one or more of the uses identified in Section 6.11.5.

A Building shall be considered in municipal use if substantially all of that Building was actively used for municipal purposes for at least 20 continuous years, including some point in the last 20 years immediately preceding an Application under this section.

A Building shall be considered in religious use if substantially all of that Building was actively used for religious purposes and protected by G.L. c. 40A §3 for at least 20 continuous years, including some point in the last 20 years immediately preceding an Application under this section provided, however, that a Building used as a religious school must have been in that use for at least 20 continuous years, including some point in the last 50 years immediately preceding an Application under this section.

Public parks and cemeteries, together with the Buildings thereon, shall not be considered in municipal use for the purpose of Section 6.11.

6.11.4 Dimensional Requirements

The following shall apply to any use for which a special permit is granted under Section 6.11:

There shall be no minimum lot area per dwelling unit requirement for the Building for which the Special Permit is issued.

Any rooftop construction needed for Building circulation, drainage, ventilation, utilities, accessibility features or passive recreation shall be excluded from the calculation of Building height. Existing fences and bordering walls may be replaced and/or extended to a height equal to the existing fence or bordering walls or 6 feet whichever is greater.

The Planning Board may, in issuing a special permit hereunder, allow structural extensions and alterations to existing nonconforming Buildings where the Planning Board finds that: (1) those changes are necessary for purposes of public health and safety, access for disabled persons, utilities, mechanical equipment or code compliance concerns and (2) those extensions and alterations shall not be substantially more detrimental than the existing nonconformity.

6.11.5 Uses Allowed by Special Permit

The Planning Board, upon a finding that a proposed use is in harmony with the purpose and intent of this Section 6.11, may grant a special permit pursuant to this Section 6.11 and Section 9.4 for one or more of the following uses in a Building that meets the eligibility requirements of Section 6.11.3; provided, however that Commercial uses may only be located within a multifamily dwelling and may not exceed 30 percent of the gross floor area of said multifamily dwelling. In addition, for any Building in the R1, R2, R3, and RC Districts, the Planning Board may grant such special permit that includes a Commercial use only upon finding that the public good will be served and that the Commercial use would not adversely affect the underlying residential district.

Special Permit Uses:

1. Dwelling, Multi-family.
2. Meeting and gathering space incidental to a principal use or for use by residents or tenants of a Lot.
3. Artist lofts and living space, studios, workrooms and shops of artists, artisans and craftsmen, where products of the artistic endeavor or craft activity can be for sale on the premises or by specific off-premises commission from a sponsor or client.
4. Banks and savings and loan institutions.
5. Barber shops and beauty parlors.
6. Books, stationery and gift stores.
7. Business and professional offices.
8. Crafts, related stores selling jewelry, crafts, etc. where production occurs on the premises.
9. Dwelling units above first floor retail, personal service, or office use.
10. Florist shops, but excluding greenhouses.
11. Galleries.
12. Laundromats/dry cleaning establishments, excluding onsite dry cleaning.
13. Medical and dental offices.
14. Specialty food stores, including grocer, candy store, meat market, delicatessen, or bakery, but not a restaurant or fast food establishment unless permitted by the underlying zone.
15. Tailor and custom dressmaking shops.
16. Not for profit museums.

The Planning Board may issue a special permit hereunder allowing the combination of any of the uses listed in Section 6.11.5 with one or more uses permitted as of right or by special permit in the applicable zoning district or the R2 zone.

Nothing set forth in this Section 6.11 shall be construed as requiring a special permit where the owner of a property in municipal use or religious use seeks to convert that use to one or more uses that are allowed as of right in the applicable zoning district.

6.11.6 Site Plan Review

Each project submitted hereunder shall require site plan approval under Section 9.5. Absent special circumstances, applications under Section 6.11.5 for a special permit and under 6.11.6 for site plan approval should be filed together for contemporaneous consideration by the Planning Board.

6.11.7 Historical Commission and Design Review Board Review

No later than at the time of an application under this Section 6.11, the applicant shall provide a copy of the application to the City of Salem Historical Commission and the Design Review Board. The Historical Commission and the Design Review Board shall each review the application at a public meeting and shall provide advisory comments to the Planning Board. Those boards may review the application at a joint meeting or separately. The Historical Commission and Design Review Board shall review the application for conformance to the Secretary of the Interior's Standards for the Treatment of Historic Properties. The Planning Board shall not take final action on an application under this Section 6.11 until it receives written confirmation from the Historical Commission and the Design Review Board that the application conforms to the Secretary of the Interior's Standards. The Planning Board may take action if at least sixty (60) days have passed since delivery of the application to the Historical Commission and the Design Review Board and the Planning Board has not received any findings from the Historical Commission or Design Review Board during the sixty (60) day period. Said sixty (60) day period may be extended by written agreement between the Applicant and Planning Board.

Nothing set forth in this Section is intended to alter or amend the rights and obligations of the Historical Commission pursuant to the G.L. c. 40C.

Failure of an applicant hereunder to timely deliver a copy of the application to the Historical Commission or Design Review Board may be grounds for denial of the application.

6.11.8 Parking and Loading

For new residential dwelling uses, provisions shall be made for not less than one (1) parking space per dwelling unit for existing buildings. On-street parking shall not count toward this requirement.

Notwithstanding anything to the contrary, housing built under the jurisdiction of the Salem Housing Authority for elderly and/or handicapped persons shall require one-third (1/3) parking space per dwelling unit.

Nonresidential uses shall provide parking in accordance with Section 5.1.8 Table of Required Parking Spaces.

In mixed-use developments, the Planning Board may consider a reduction in total parking requirements based on an analysis of peak demand for non-competing uses provided by the applicant. In such cases the parking requirement for the largest of the uses (in terms of parking spaces required) shall be sufficient as determined by the Planning Board. An applicant shall use the latest peak demand analyses published by the Institute of Traffic Engineers (ITE) or other source acceptable to the Planning Board.

The parking requirements may be accommodated by either one or a combination of on-site parking and/or parking at municipal or other parking facilities in the vicinity of the Lot. All municipal or other parking facilities which are used to satisfy the parking requirement must meet the following criterion: The parking facility must be fewer than one thousand (1,000) feet from the Lot as measured in a straight line from the two (2) closest points between the Lot and the parking facility. If using a municipal facility, the owner must purchase an annual parking pass to satisfy the parking requirement.

Such properties will not be eligible for resident parking permits to fulfill these requirements.

A new loading zone shall not be required if the existing Building does not have an existing loading zone.

6.11.9 Severability

The provisions of this Section 6.11 are severable. The invalidity of any paragraph, subsection or provision of this Section 6.11 shall not invalidate any other paragraph, subsection or provision hereof.

In City Council May 9, 2019

Refer to the Planning Board to hold a Joint Public Hearing

Joint Public Hearing held on June 17, 2019

Joint Public Hearing Closed and referred to the Planning Board for Recommendations

In City Council June 27, 2019

Motion to refer to the Committee on Ordinances, Licenses and Legal Affairs co-posted with the Committee of the Whole was denied

Motion to add the deleted sentence in Section 6.11.8 back was voted in the affirmative

Motion for reconsideration to refer the matter to the Committee on Ordinances, Licenses and Legal Affairs co-posted with the Committee of the Whole passed

Reconsideration to be taken up at the next meeting

CITY OF SALEM

In the year Two Thousand and Nineteen

An Ordinance to amend an Ordinance relative to Traffic,

Be it Ordained by the City Council of the City of Salem, as follows:

SECTION 1. Amending Chapter 42 Section 11 – “Bus Stops”

By adding the following:

Lafayette Street – BUS STOPS – easterly side, for a distance of fifty-four (54) feet beginning at the driveway of 287 Lafayette Street in a northerly direction.

SECTION 2. This ordinance shall take effect as provided by City Charter

In City Council June 27, 2019
Adopted for first passage

ATTEST:

ILENE SIMONS
CITY CLERK

CITY OF SALEM

In the year Two Thousand and Nineteen

An Ordinance to amend an Ordinance relative to Traffic,

Be it Ordained by the City Council of the City of Salem, as follows:

SECTION 1. Chapter 42, Section 54A – “Reserved Parking, Holyoke Square”

Be amended by repealing the following:

Parking shall be reserved in accordance with the Salem Redevelopment Authority Deed of Easement recorded at Book 22087, Page 438, which restricts parking exclusively for Holyoke Square, Inc. during regular business hours, defined as Monday through Friday, from 7:30 a.m. to 5:30 p.m., at 13 parking spaces along the Holyoke Square side of so much of the public ways known as Norman Street and Holyoke Square as about Holyoke's property at Holyoke Square.

A violation of this Ordinance shall be considered a violation of a restricted parking area.

And replacing it with the following:

Parking shall be reserved in accordance with the Salem Redevelopment Authority Deed of Easement recorded at Book 22087, Page 438, which restricts parking exclusively for Holyoke Square, Inc. (NKA CDX Analytics, LLC) during regular business hours, defined as Monday through Friday, from 7:30 a.m. to 5:30 p.m., at 6 parking spaces along the Holyoke Square side of so much of the public way known as Norman Street which are identified as spaces numbered 1, 2, 3, 4, 5 and 6 on the Easement Plan of land for Holyoke Square recorded at Plan Book 372, Plan No. 64 in the Southern Essex Registry of Deeds.

A violation of this Ordinance shall be considered a violation of a restricted parking area.

SECTION 2. This ordinance shall take effect as provided by City Charter

In City Council June 27, 2019
Adopted for first passage

ATTEST:

ILENE SIMONS
CITY CLERK