

February 10, 2021

Attn: Salem MA City Council

To Whom It May Concern:

National Grid, as owner of certain utility poles in public rights-of-way in Salem, MA, is aware and authorizes Verizon Wireless to complete the process of permitting for the installation of necessary telecommunications equipment and corresponding aerial fiber optic cable on National Grid-owned utility poles at the following location (s);

VZW Site Name	Address
Salem_SC22_MA	204 Lafayette St, Pole 3268

Accordingly, National Grid hereby submits its authorization for Verizon Wireless to install its antennae and appurtenant equipment and aerial fiber routes to National Grid poles at the above locations. Please be advised that the undersigned has entered into a master lease agreement authorizing Verizon Wireless to install, attach, maintain, repair, upgrade and use wireless communications equipment and appurtenances on certain utility poles. The installations on National Grid utility poles will be subject to the underlying terms and conditions of the aforementioned agreement by and between National Grid and Verizon Wireless, as the same may be in effect from time to time.

Sincerely,



Keith Amelin
National Grid



1/26/2021

To: City of Salem

Transmitted via email

RE: Verizon Wireless Small Cell Sites

Dear City of Salem,

Verizon is installing additional wireless telecommunications facilities in order to meet the growing demand for Verizon Wireless service by residents, businesses, visitors, and emergency responders.

To ensure general public safety, it is important that you contact Verizon Wireless personnel at least 24 hours in advance should general maintenance need to be performed in areas of potential concern as marked on the next page of this document. This is required to comply with FCC guidelines and ensure the environment is safe for general maintenance workers who may require RF Safety & Awareness training. With notification, Verizon Wireless is able to evaluate appropriate actions needed relating to the antennas and proximity of the work location.

Thank you for your inquiry. Verizon has a process to deactivate power on small cells (regardless of whether the small cell is 4G or 5G) while work is being done on the pole (including joint use poles). The information needed to have a small cell powered down for work to occur on the pole (including contact numbers and pole identifiers) is provided at a safe distance from the small cell on the pole itself. Please contact Verizon Wireless personnel at least 24 hours in advance if you need to perform maintenance at that site. If you have any additional questions, our point of contact in that area is Luis Teves.

You also expressed concerns about the health effects of RF emissions from Verizon's network equipment. The Federal Communications Commission (FCC) has developed safety rules for human exposure to RF emissions in consultation with numerous other federal agencies, including the Environmental Protection Agency, the Food and Drug Administration, and the Occupational Safety and Health Administration. These rules can be found at 47 C.F.R § 1.1310. No matter which generation of technology we use, all Verizon equipment must comply with these safety requirements.

The FCC supported and adopted the standards after examining the RF research that scientists in the US and around the world conducted for decades. The research continues to this day, and agencies continue to monitor it. Based on that research, federal agencies have concluded that equipment that has been deployed in a manner that complies with the safety standards poses no known health risks. You can obtain further information about the safety of RF emissions from cell towers on the FCC's website, which you can access via this link: <http://www.fcc.gov/oet/rfsafety/rf-faqs.html>.

Thank you for reaching out to us regarding your concerns. We appreciate the chance to explain our activities regarding the wireless facility at issue. Questions related to compliance with federal regulations should be directed to VZWRFCompliance@verizonwireless.com. Please contact your local Verizon Wireless resource below if you have any additional questions.

Contact Name	Contact Email	Contact Phone
Luis Teves	Luis.Teves@VerizonWireless.com	508-479-3197

Sincerely,

Rabeya Ahmad
Sr Manager - RF Design
Verizon Wireless



April 16, 2021

John Giardi
Central Fire Headquarters
44 Lafayette Street – Second Floor
Salem, MA. 01970

RE: Verizon Wireless application for Small Cell Telecommunications Attachments in the Right of Way.

Dear Mr. Giardi,
Verizon Wireless is proposing to attach telecommunications equipment to an existing National Grid utility pole located in the public right of way at the following location:

Site Name	Address Information	Coordinates	Pole Number
SALEM SC22 MA	204 Lafayette Street	42.513161, 70.892342	52/2503

Pursuant to the Verizon Wireless - Master Lease Agreements with National Grid, Verizon, and the City of Salem. Enclosed please find the following items requested for each site location:

- Application Fee in the amount of \$500
- Letter of Authorization from National Grid
- Routing Slip for Telecommunications Attachments in the Right of Way.
- Lease Exhibit
- Structural Analysis – Pole Calculations
- RF Emissions Report
- Mailing Labels
- Verizon Wireless and Verizon – Pole Attachment Agreement

Please reach out to me with any questions or additional requirements.

Thank you in advance for your assistance.

Best Regards,

Danielle Sabourin
Site Acquisition Specialist II
Airosmith Development, Inc.
(508) 446-7180 Cell
dsabourin@airosmithdevelopment.com

318 West Avenue, Saratoga Springs, NY 12866
Main Office / Fax: 518-306-1711
www.airosmithdevelopment.com



ROUTING SLIP

Telecommunications Attachments in the Public Right of Way

Pursuant to the Code of Ordinances, Sections 12-86 through 12-200, each applicant who seeks access to the public right of way for telecommunications purposes must submit a petition and plans along with a \$500 application fee to the Electrical Department. Once the City Electrician has signed off, please circulate to the Departments listed on the reverse side of this Routing Slip for signature with a courtesy copy to the Ward Councillor and return it to the City Clerk's Office prior to the petition being placed on the City Council Agenda for a grant of location pursuant to MGL Chapter 166, Section 22.

Right of Way Location Requested: 204 Lafayette Street / (42.513161 -70.892342)

City Ward: 5

Link to Plans Online: _____

Application Fee Received: Yes Check No. 8154 Date: 4/16/2021

City Electrician Approval: _____

BUSINESS NAME

Corporate name: Verizon Wireless

d/b/a: _____

Address: 18 Flanders Rd. Westborough, MA 01581 Tele. # _____

CONTACT: Danielle Sabourin / Agent / Airosmith Development

Street: 318 West Ave. Tele. # 508-446-7180

City: Saratoga Springs State: NY Zip: 12866

Email Address: dsabourin@airosmithdevelopment.com

Pole Ownership

To be attached to utility-owned pole To be attached to City-owned pole

Pole Attachment Agreement attached* Pole Attachment Agreement to follow*

*All grants of location for telecommunications attachments to poles are conditioned upon evidence of a valid pole attachment agreement.

Conduits

Will the attachment also require an underground conduit? Yes No

**Salem
Abutters List**

Subject Parcel ID: b

Subject Property Location:

ParcelID	Location	Owner	Co-Owner	Mailing Address	City	State	Zip
33-0211-0	208 LAFAYETTE STREET	HEIDI REALTY PARTNERSHIP	MARKOS CONSTANCE TR	241 LAFAYETTE STREET	SALEM	MA	01970
33-0212-0	204 LAFAYETTE STREET	LAFAYETTE HOLDINGS, LLC		11 MOSES HILL ROAD	MANCHESTER	MA	01944
33-0213-0	200 LAFAYETTE STREET	SCANZANI PAUL		200 LAFAYETTE ST	SALEM	MA	01970

Parcel Count: 3

End of Report



SALEM_SC22_ CLUSTER: SALEM

UTILITY POLE #52/2503
204 LAFAYETTE STREET (MA R
SALEM, MA 01970



SITE CONTROL POINT:
CENTER OF EXISTING UTILITY POLE #52/2503
N 42.513161° (42°-30'-47.38")
W 70.892342° (70°-53'-32.43")
APPROXIMATE GROUND ELEVATION - 26± AMSL

LOCATION PLAN/AERIAL IMAGE



GENERAL NOTES:

1. THESE DRAWINGS ARE DIAGRAMMATIC IN NATURE AND ARE INTENDED TO PROVIDE GENERAL INFORMATION REGARDING THE LOCATION, SIZE AND ORIENTATION OF THE PROPOSED WIRELESS TELECOMMUNICATIONS EQUIPMENT INSTALLATION ON THE UTILITY POLE AND ARE NOT SPECIFICALLY INTENDED FOR CONSTRUCTION.
2. VERIZON WIRELESS SHALL PLACE WEATHER RESISTANT PHENOLIC PLACARDS ON UTILITY POLE AND ANCILLARY EQUIPMENT TO IDENTIFY EQUIPMENT OWNERSHIP & CONTACT INFORMATION TO BE UTILIZED IN THE CASE OF EMERGENCY.
3. AN ANALYSIS OF THE CAPACITY OF THE EXISTING UTILITY POLE TO SUPPORT THE PROPOSED LOADING HAS NOT BEEN COMPLETED BY CHAPPELL ENGINEERING ASSOCIATES, LLC. AND THUS, THESE DRAWINGS ARE SUBJECT TO CHANGE PENDING THE OUTCOME OF A STRUCTURAL ANALYSIS (TO BE PERFORMED BY OTHERS).
4. VERIZON WIRELESS' GENERAL CONTRACTOR SHALL EXTEND EFFORTS TO ENSURE THAT ALL PROPOSED EQUIPMENT MEETS THE REQUIREMENTS OF THE EXISTING UTILITY COMPANY OR COMPANIES CURRENTLY OCCUPYING THE UTILITY POLE AND THE 2017 NATIONAL ELECTRICAL SAFETY CODE.

ANTENNA AND MOUNT NOTE:
 CONTRACTOR SHALL POSITION/ROTATE PROP. ANTENNA MOUNT/BACKET IN SUCH A WAY SO AS TO NOT INTERFERE WITH EXIST. STREET LIGHT, PRIMARY POWER CROSSARM(S) (IF PRESENT), BRACKETS, BRACES, SECONDARY POWER SUPPORTS OR ANY OTHER MISCELLANEOUS APPURTENANCES AND RELATED SUPPORT BRACKETS ENCOUNTERED LOCATED ON THE EXIST. UTILITY POLE.

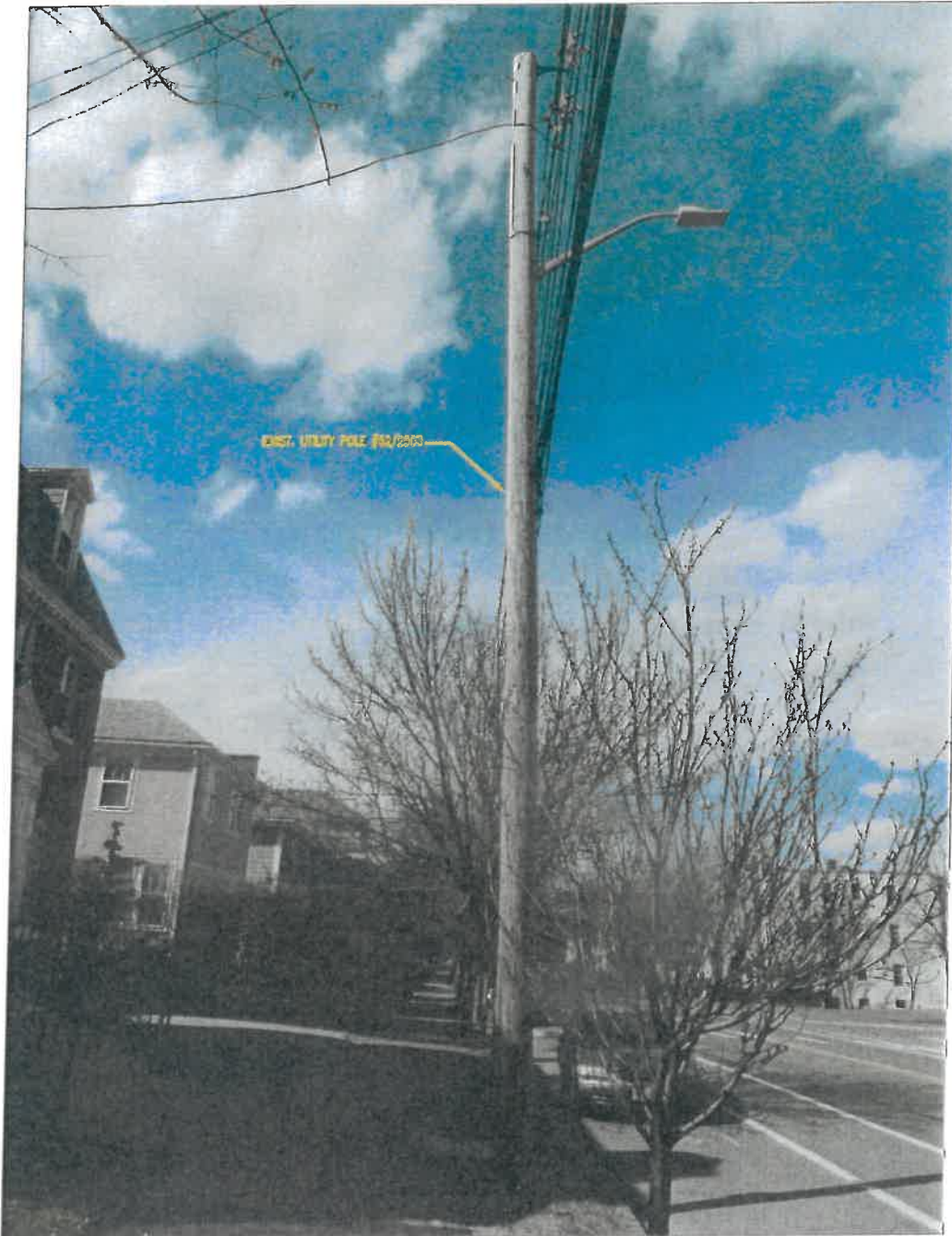

EQUIPMENT AND MOUNT NOTE:
 CONTRACTOR SHALL POSITION/ROTATE PROP. EQUIPMENT AND ASSOCIATED MOUNTS/BACKETS IN SUCH A WAY SO AS TO NOT INTERFERE WITH EXIST. WIRES/PANELS ETC. OR ANY OTHER MISCELLANEOUS APPURTENANCES AND RELATED SUPPORT BRACKETS ENCOUNTERED LOCATED ON THE FACE OF THE EXIST. UTILITY POLE.

LEGEND

- BLUE — = FIBER BUNDLE/J1
- RED — = AC POWER
- ORANGE — = DC POWER
- GREEN — = GROUND
- BLUE — = 1/2" SUPERFLE

NOTE:
 UTILITY POLE, E AND DETAILS OF SHOWN SCHEMA

UTILITY POLE #52/2503 PHOTOGRAPH (EXISTING CONDITIONS)
 SCALE: NO SCALE

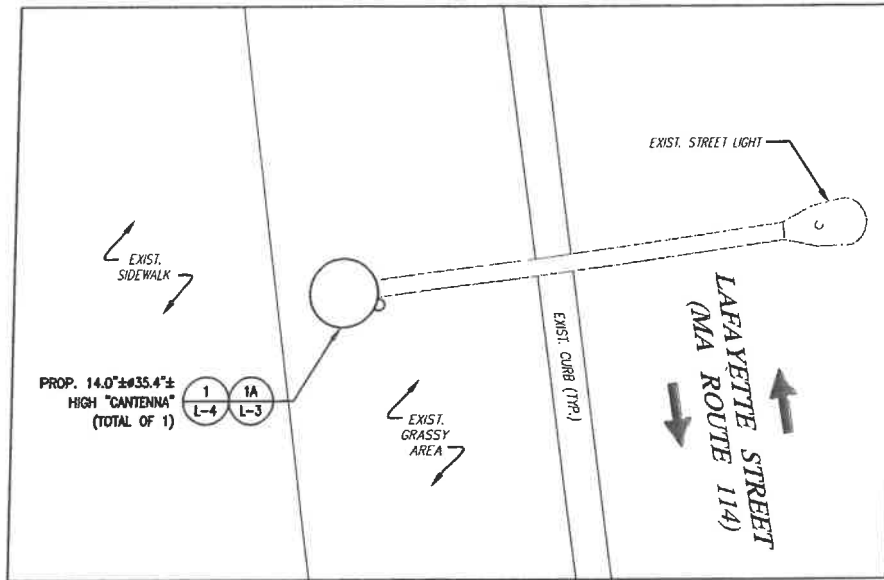

ANTENNA ORIENTATION PLAN
 SCALE: 3/8" = 1'-0"
 0 2'-8" 5'-4" 8'-0"

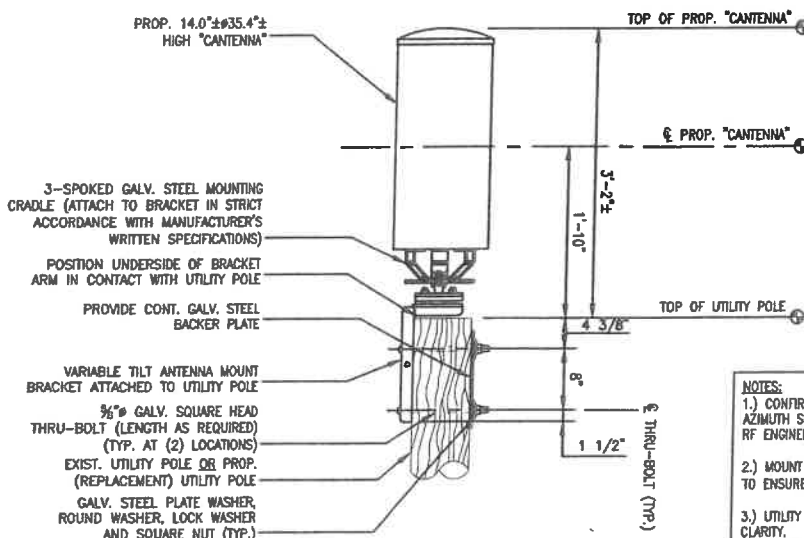

"CANTENNA" MOUNT DETAIL
 SCALE: 1/2" = 1'-0"

NOTES:
 1.) CONFIRM DOWNTILT REQUIREMENTS (IF ANY) AND AZIMUTH SPECIFICATIONS WITH VERIZON WIRELESS RF ENGINEER AT TIME OF CONSTRUCTION.
 2.) MOUNT SHALL BE INSTALLED IN SUCH A WAY TO ENSURE PLUMB INSTALLATION OF "CANTENNA".
 3.) UTILITY POLE APPURTENANCES NOT SHOWN FOR CLARITY.

OUTLINE (MOUNT) MOUNTING BRACK SPECIFICATIONS
 GALV. STEEL MOUNTING POWDER COATING A
 PROP. UP (RRH) U SPECIFICATIONS
 PROP. LOWER RI UNIT MOUNT MOUNTING BRACK SPECIFICATIONS
 OUTLINE OF F TO PLAT BRACK SPECIFICATIONS
 5/8 HEAD LOCK 1 (S
 (S

A SC



SMALL CELL "CANTENNA"	
DIMENSIONS:	14.0"±0 x 35.4"±H
WEIGHT:	35.0± LBS
QUANTITY:	TOTAL OF 1

TYPICAL "CANTENNA" SPECIFICATIONS

SCALE: N.T.S.

1
L-4



REMOTE RADIO HEAD UNIT	
DIMENSIONS:	17.3"±H x 17.3"±W x 11.5"±D
WEIGHT:	102.5± LBS
QUANTITY:	TOTAL OF 1



REMOTE RADIO HEAD UNIT	
DIMENSIONS:	13.9"±H x 9.6"±W x 4.8"±D
WEIGHT:	21.4± LBS
QUANTITY:	TOTAL OF 1

TYPICAL REMOTE RADIO HEAD (RRH) UNIT DIMENSIONS

SCALE: N.T.S.

2
L-4



DIPLEXER	
DIMENSIONS:	4.8"±H x 7.9"±W x 3.3"±D
WEIGHT:	7.6 LBS
QUANTITY:	TOTAL OF 1

TYPICAL DIPLEXER DIMENSIONS

SCALE: N.T.S.

3
L-4

PROP.
CIRC/
COVER. BC
CIRCUIT B
(1) FOR /
LOAD CENT

Verizon Wireless (VZW) Radiofrequency (RF) Emissions Map

The following site layout represents a current snapshot in time of the predicted Verizon Wireless RF emissions from transmitting antennas on this facility. Contact Verizon Wireless should maintenance need to be performed in any non-green areas.

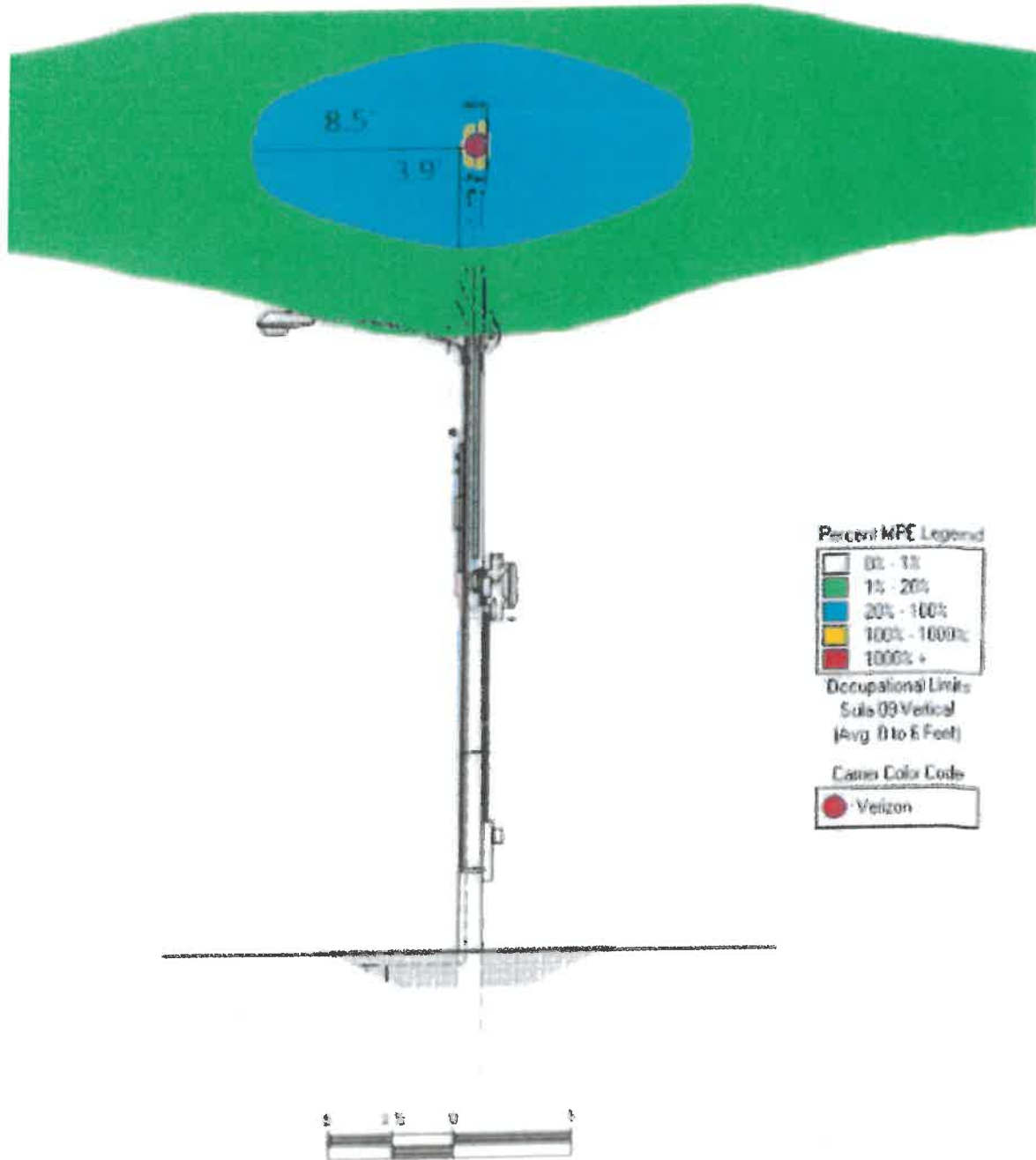

Color	% Occupational MPE	Instructions
Green	0 to 20	Safe In Relation to VZW. Contact Other Carriers Before Entering This Area Contact VZW Before Accessing This Area
Blue	20 to 100	
Yellow	Greater Than 100	
Red	Greater Than 1000	

The Verizon logo, consisting of the word "verizon" in a lowercase, sans-serif font with a red checkmark above the "i", is positioned in the top right corner of the document. The background of the entire page is a grayscale photograph of a cityscape featuring several tall buildings and numerous communication towers with antennas on their roofs.

verizon

RADIOFREQUENCY EMISSIONS

SAFETY & AWARENESS
REFERENCE GUIDE

This handout is not intended to replace the FCC/OSHA mandated occupational requirement for RF Safety & Awareness Training

FEDERAL COMPLIANCE REQUIREMENTS

The Federal Communications Commission (FCC) has established safety guidelines relating to RF exposure from cell sites. The FCC developed those standards, known as Maximum Permissible Exposure (MPE) limits, in consultation with numerous other federal agencies, including the Environmental Protection Agency, the Food and Drug Administration, and the Occupational Safety and Health Administration.

The standards were developed by expert scientists and engineers after extensive reviews of the scientific literature related to RF biological effects. The FCC explains that its standards incorporate prudent margins of safety.

CLASSIFICATIONS FOR EXPOSURE LIMITS

OCCUPATIONAL

Persons are "exposed as a consequence of their employment" and are "fully aware of the potential for exposure and can exercise control over their exposure".

GENERAL POPULATION

Any persons that "may not be made fully aware of the potential for exposure or cannot exercise control over their exposure".

Those in this category do not require RF Safety & Awareness Training.

ENSURING COMPLIANCE WITH FCC GUIDELINES

Areas or portions of any transmitter site may be susceptible to high power densities that could cause personnel exposures in excess of the FCC guidelines. Wireless Licensees are required by law to implement the following:

- Restrict access
- Post notification signage on every access point to increase awareness of the potential for exposure BEFORE one enters an area with antennas.
- Place additional notification signage and visual indicators in an area with antennas (beyond an access point) where RF exposure levels may start to exceed the FCC's limits.

MPE CHART

Category	MPE Level	Person MPE	
		General Population	Occupational
Control Area	4	1,000 W/m ²	10,000 W/m ²
Control Area	3	100 W/m ²	1,000 W/m ²
Control Area	2	10 W/m ²	100 W/m ²
Control Area	1	1 W/m ²	10 W/m ²

EXPOSURE MANAGEMENT

- Assume that all antennas are active
- Obey all posted signs
- Do not stop in front of any antenna
- Recognize the type of antenna and approach at the safest angle
- Contact wireless operator to coordinate access if required
- Signage will indicate where potential RF conditions exist
- Understand pathways of safe egress
- If needed and possible wear personal protection equipment
- When using a personal monitor, remember the time averaging limits and monitor alarm thresholds if working in front of antennas
- If experiencing symptoms of heat exhaustion or nausea, remove yourself from the worksite and seek medical attention
- Power density decreases with distance so maintain distance between you and the antennas. The greater the distance you are from an antenna the bigger the reduction of RF exposure you will receive

PROPERTY OWNER RESPONSIBILITIES (M.E.N.U.)

RF exposure safety and the protection of every licensee's infrastructure are very important. Property owners and licensees have a shared responsibility in maintaining a safe and secure RF environment. Property owners can help in this significant endeavor by:

- **M**aintaining all necessary wireless licensee contact information.
- **E**nsuring restricted access (help maintain a Controlled Environment). Ensuring all building/maintenance personnel are trained in RF Safety, aware that the potential for exposure exists, and follow all appropriate entry and safety procedures.
- **N**otifying all licensees when any non-carrier requests access to any area with antennas at least 24 hours in advance.
- **U**nderstanding that compliance with the FCC and OSHA can be achieved with RF Exposure levels above the applicable limit if the proper signage, physical/indicative barrier, and access restrictions are implemented. Commitment to compliance and willingness to cooperate are essential.

NOTIFICATION SIGNS



A blue Notice sign is posted when levels (beyond posted signage) may exceed General Population MPE limits.



A yellow Caution sign is posted when levels (beyond posted signage) may exceed Occupational MPE limits.



An orange Warning sign is posted when levels (beyond posted signage) exceed 10 times the Occupational MPE limits.

TYPES OF ANTENNAS

MICROWAVE ANTENNA

- Highly directional antenna model used for point to point communications
- Approach from the rear and sides. Do not stand or walk in front of microwaves as they transmit at a high frequency.



PANEL ANTENNA

- Range from 1 to 8 feet in length
- Sled mounted or to a support structure on site (Rooftop)
- Approach these antennas from the rear.



OMNI ANTENNA

- Omni antennas have the appearance of a rod-shaped pole and radiate in a 360° pattern around the pole.
- At the antenna level, there is no approach angle that is safer than another. Typically, emissions directly below the antenna are less than in front of the antenna.



QUASI-OMNI ANTENNA

- Quasi-Omni antennas have the appearance of a cylinder and contain emitters that radiate in a 360° pattern around the pole.
- At the antenna level, there is no approach angle that is safer than another. Typically, emissions directly below the antenna are less than in front of the antenna.



YAGI ANTENNA

- Directional antenna model
- Approach from sides and rear.



RF SAFETY TRAINING CONTACTS

WATERFORD CONSULTANTS www.waterfordconsultants.com
 EBI www.ebiconsulting.com
 SITESAFE www.sitesafe.com
 DTECH COMMUNICATIONS..... www.dtech.com

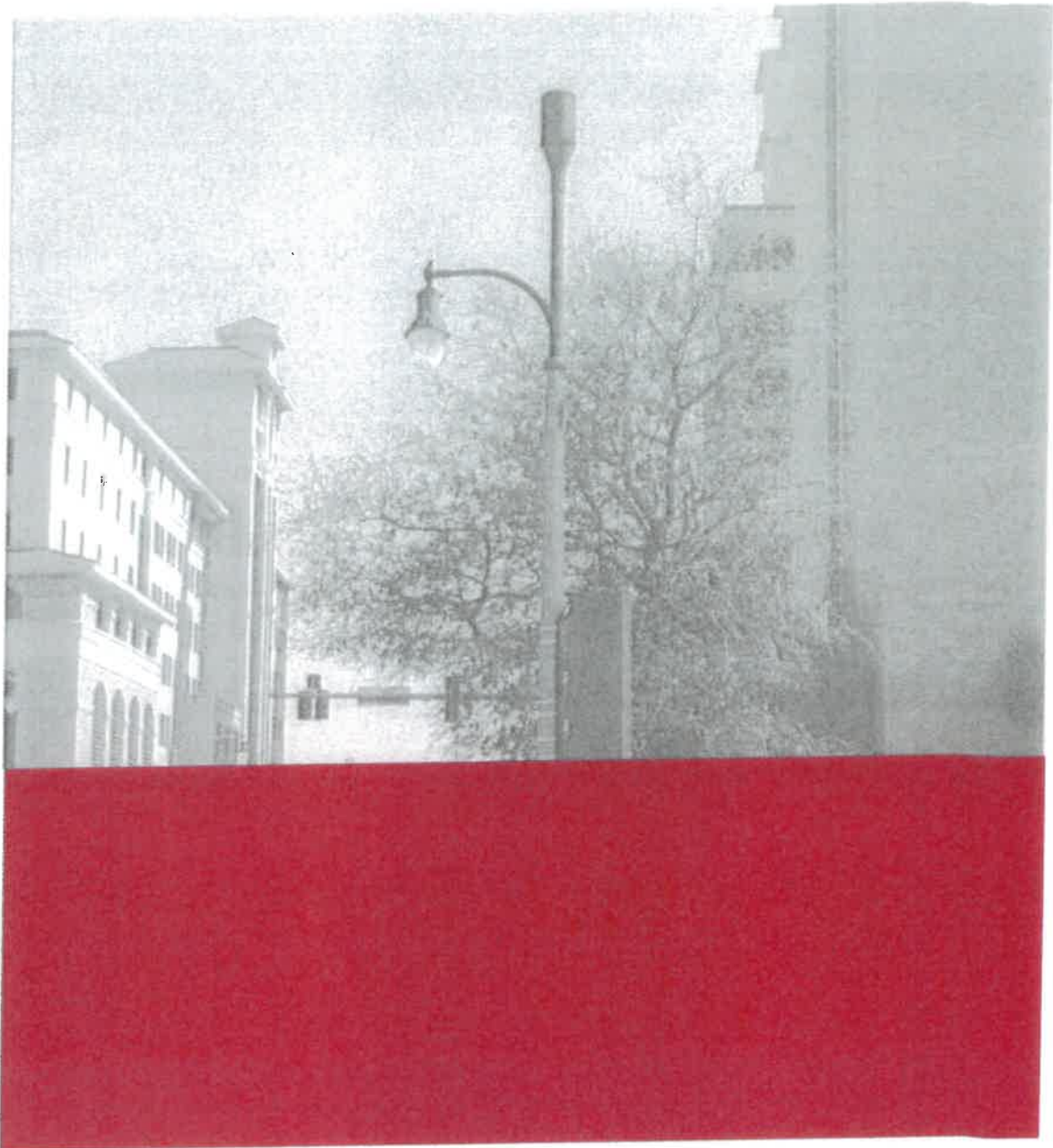

CONTACT US

Email: VZWRFCompliance@vzw.com
Subject: "ATTN:RF Compliance"

For Emergency Maintenance:
1-800-264-6620

verizon ✓

Pole Num:	2503	Lafayette St	Pole Length / Class:	45 / 2	Code:	NESC	Stru
Aux Data 1		Unset	Species:	SOUTHERN PINE	NESC Rule:	Rule 250B	Stat
Aux Data 2		Unset	Setting Depth (ft):	8.16	Construction Grade:	C	Pole
Aux Data 3		Unset	G/L Circumference (in):	41.75	Loading District:	Heavy	Trar
Aux Data 4		Unset	G/L Fiber Stress (psi):	8,000	Ice Thickness (in):	0.50	Wire
Aux Data 5		Unset	Allowable Stress (psi):	6,800	Wind Speed (mph):	39.53	Vert
Aux Data 6		Unset	Fiber Stress Ht. Reduc:	No	Wind Pressure (psf):	4.00	
Latitude:			0 Longitude:			0	Elev

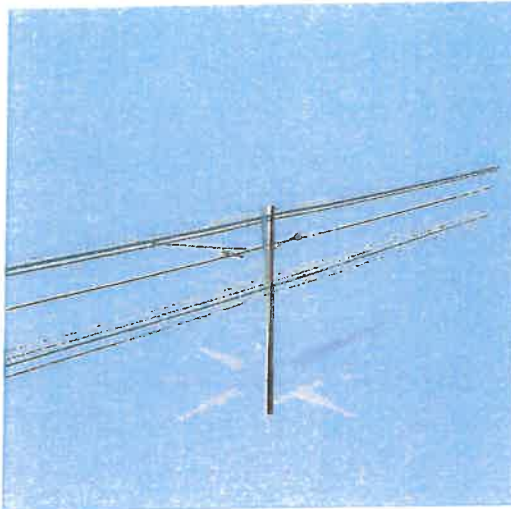

Pole Capacity Utilization (%)	
Maximum	38.1
Groundline	38.1
Vertical	8.4

Pole Moments (ft-lb)	
Max Cap Util	48,975
Groundline	48,975
GL Allowable	130,571

Groundline Load Summary - Reporting Angle Mode: Load - Reporting Angle: 263.1°

	Shear Load* (lbs)	Applied Load (%)	Bending Moment (ft-lb)	Applied Moment (%)	Pole Capacity (%)	Bending Stress (+/- psi)	Vertical Load (lbs)	Ve St (i)
Powers	1,152	56.8	33,033	67.5	25.3	1,821	1,312	
Comms	628	30.9	11,900	24.3	9.1	656	1,067	
Pole	227	11.2	3,950	8.1	3.0	218	2,639	
Streetlights	20	1.0	20	0.0	0.0	1	114	
Insulators	2	0.1	71	0.2	0.1	4	65	
Pole Load	2,030	100.0	48,975	100.0	37.5	2,700	5,197	
Pole Reserve Capacity			81,596		62.5	4,100		

Load Summary by Owner - Reporting Angle Mode: Load - Reporting Angle: 263.1°

	Shear Load* (lbs)	Applied Load (%)	Bending Moment (ft-lb)	Applied Moment (%)	Pole Capacity (%)	Bending Stress (+/- psi)	Vertical Load (lbs)	V S
NGrid	1,155	56.9	33,103	67.6	25.4	1,825	1,329	
Fiber	299	14.7	6,034	12.3	4.6	333	461	
Catv	179	8.8	3,331	6.8	2.6	184	296	
Telco	150	7.4	2,536	5.2	1.9	140	347	
Pole	227	11.2	3,950	8.1	3.0	218	2,639	
Municipal	20	1.0	20	0.0	0.0	1	114	
<Undefined>	0	0.0	0	0.0	0.0	0	10	
Totals:	2,030	100.0	48,975	100.0	37.5	2,700	5,197	

Detailed Load Components:

Power	Owner	Height (ft)	Horiz. Offset (in)	Cable Diameter (in)	Sag at Max Temp (ft)	Cable Weight (lbs/ft)	Lead/Span Length (ft)	Span Angle (deg)	Wire Length (ft)	Tension (lbs)	
Primary	AAC 477.0 KCM 19 STRAND AAC 160mil CVRD TW 6-117	NGrid	35.62	28.01	1.0420	0.637	97.8	0.0	97.8		
Primary	AAC 477.0 KCM 19 STRAND AAC 160mil CVRD TW 6-117	NGrid	35.62	18.01	1.0420	0.637	97.8	0.0	97.8		
Primary	AAC 477.0 KCM 19 STRAND AAC 160mil CVRD TW 6-117	NGrid	34.79	23.01	1.0420	0.637	97.8	0.0	97.8		
Primary	AAC 477.0 KCM 19 STRAND AAC 160mil CVRD TW 6-117	NGrid	35.62	28.01	1.0420	0.637	90.3	181.0	90.3		
Primary	AAC 477.0 KCM 19 STRAND AAC 160mil CVRD TW 6-117	NGrid	35.62	18.01	1.0420	0.637	90.3	181.0	90.3		
Primary	AAC 477.0 KCM 19 STRAND AAC 160mil CVRD TW 6-117	NGrid	34.79	23.01	1.0420	0.637	90.3	181.0	90.3		
Secondary	TRIPLEX 1/0 10-5	NGrid	29.37	7.02	1.0300	1.19	0.399	97.8	0.0	97.8	1,065
Secondary	TRIPLEX 1/0 10-5	NGrid	29.37	7.02	1.0300	1.08	0.399	90.3	181.0	90.3	1,065
Secondary	TRIPLEX 4 AWG	NGrid	29.24	60.29	0.6800	0.29	0.164	27.3	245.0	27.3	558
Overlashed Bundle	477KCM Spacer: 1/0, 2/5 AWAC 16-31	NGrid	36.45	23.01	0.5410	0.58	0.428	97.8	0.0	97.8	6,009
Overlashed Bundle	477KCM Spacer: 1/0, 2/5 AWAC 16-31	NGrid	36.45	23.01	0.5410	0.50	0.428	90.3	181.0	90.3	6,009
Totals:											

Comm	Owner	Height (ft)	Horiz. Offset (in)	Cable Diameter (in)	Sag at Max Temp (ft)	Cable Weight (lbs/ft)	Lead/Span Length (ft)	Span Angle (deg)	Wire Length (ft)	Tension (lbs)
Overlashed Bundle	Fiber	22.87	7.49	0.2500	0.37	0.121	97.8	0.0	97.8	1,663
Fiber	Fiber	22.83	7.49	1.0000		0.046	97.8	0.0	97.8	
Overlashed Bundle	Fiber	22.87	7.49	0.2500	0.32	0.121	90.3	181.0	90.3	1,663
Fiber	Fiber	22.83	7.49	1.0000		0.046	90.3	181.0	90.3	
Overlashed Bundle	Fiber	21.70	7.57	0.2500	0.37	0.121	97.8	0.0	97.8	1,663
Fiber	Fiber	21.65	7.57	1.0000		0.046	97.8	0.0	97.8	
Overlashed Bundle	Fiber	21.70	7.57	0.2500	0.32	0.121	90.3	181.0	90.3	1,663
Fiber	Fiber	21.65	7.57	1.0000		0.046	90.3	181.0	90.3	
Overlashed Bundle	Catv	20.70	7.65	0.2500	0.52	0.121	97.8	0.0	97.8	1,663
CATV	Catv	20.63	7.65	1.5700		0.073	97.8	0.0	97.8	
Overlashed Bundle	Catv	20.70	7.65	0.2500	0.44	0.121	90.3	181.0	90.3	1,663
CATV	Catv	20.63	7.65	1.5700		0.073	90.3	181.0	90.3	
Overlashed Bundle	Telco	19.40	7.74	0.2500	0.76	0.121	97.8	0.0	97.8	1,663
Telco	Telco	19.35	7.74	1.0000		0.700	97.8	0.0	97.8	
Overlashed Bundle	Telco	19.40	7.74	0.2500	0.65	0.121	90.3	181.0	90.3	1,663
Telco	Telco	19.35	7.74	1.0000		0.700	90.3	181.0	90.3	
Totals:										

Streetlight	Owner	Height (ft)	Horiz. Offset (in)	Offset Angle (deg)	Rotate Angle (deg)	Unit Weight (lbs)	Unit Height (in)	Unit Depth (in)	Unit Diameter (in)	Unit Length (in)
General	Municipal	27.94	4.62	93.0	93.0	60.00	48.00	20.00	3.00	

Insulator	Owner	Height (ft)	Horiz. Offset (in)	Offset Angle (deg)	Rotate Angle (deg)	Unit Weight (lbs)	Unit Diameter (in)	Unit Length (in)
Davit	NGrid	36.45	0.00	90.0	0.0	8.99	3.00	14.0
	AWAC	29.37	0.00	90.0	0.0	5.00	3.00	0.1
Bolt	Fiber	22.87	0.00	90.0	0.0	5.00	3.00	0.1
Bolt	Fiber	21.70	0.00	90.0	0.0	5.00	3.00	0.1
Bolt	Catv	20.70	0.00	90.0	0.0	5.00	3.00	0.1
Bolt	Telco	19.40	0.00	90.0	0.0	5.00	3.00	0.1
Totals:								

Pole Buckling										
Buckling Constant	Buckling Column Height* (ft)	Buckling Section Height (% Buckling Col. Hgt.)	Buckling Section Diameter (in)	Minimum Buckling Diameter at GL (in)	Diameter at Tip (in)	Diameter at GL (in)	Modulus of Elasticity (psi)	Pole Density (pcf)	Ice Density (pcf)	Pole Tip Height (ft)
2.00	23.14	33.78	12.16	7.15	7.96	13.30	2.13e+6	60.00	57.00	36.84

Pole Num:	2503 Lafayette St	Pole Length / Class:	50 / 2	Code:	NESC	Struc
Aux Data 1	Unset	Species:	SOUTHERN PINE	NESC Rule:	Rule 250B	Stat
Aux Data 2	Unset	Setting Depth (ft):	7.0	Construction Grade:	C	Pole
Aux Data 3	Unset	G/L Circumference (in):	41.61	Loading District:	Heavy	Tran
Aux Data 4	Unset	G/L Fiber Stress (psi):	8,000	Ice Thickness (in):	0.50	Wire
Aux Data 5	Unset	Allowable Stress (psi):	6,800	Wind Speed (mph):	39.53	Verti
Aux Data 6	Unset	Fiber Stress Ht. Reduc:	No	Wind Pressure (psf):	4.00	
Latitude:		Longitude:				0 Elev

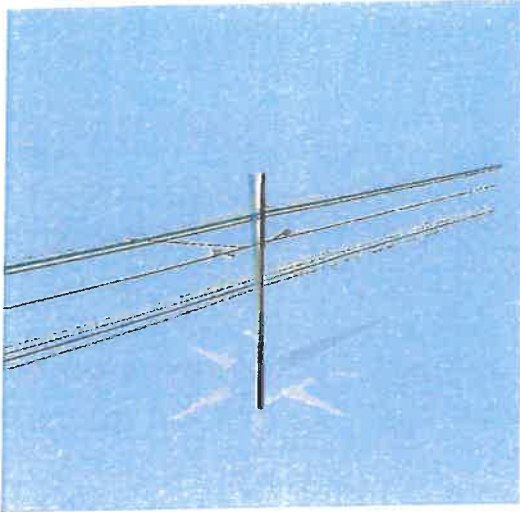

Pole Capacity Utilization (%)	
Maximum	40.1
Groundline	40.1
Vertical	9.3

Pole Moments (ft-lb)	
Max Cap Util	51,034
Groundline	51,034
GL Allowable	129,296

Groundline Load Summary - Reporting Angle Mode: Load - Reporting Angle: 263.4°

	Shear Load* (lbs)	Applied Load (%)	Bending Moment (ft-lb)	Applied Moment (%)	Pole Capacity (%)	Bending Stress (+/- psi)	Vertical Load (lbs)	Ve S (
Powers	1,152	55.7	33,213	65.1	25.7	1,847	1,312	
Comms	628	30.4	12,402	24.3	9.6	690	1,067	
Pole	265	12.8	5,318	10.4	4.1	296	3,067	
Streetlights	20	1.0	29	0.1	0.0	2	114	
Insulators	2	0.1	72	0.1	0.1	4	65	
Pole Load	2,067	100.0	51,034	100.0	39.5	2,838	5,625	
Pole Reserve Capacity			78,262		60.5	3,962		

Load Summary by Owner - Reporting Angle Mode: Load - Reporting Angle: 263.4°

	Shear Load* (lbs)	Applied Load (%)	Bending Moment (ft-lb)	Applied Moment (%)	Pole Capacity (%)	Bending Stress (+/- psi)	Vertical Load (lbs)	Ver Str (p)
NGrid	1,154	55.8	33,283	65.2	25.7	1,851	1,329	
Fiber	299	14.5	6,242	12.2	4.8	347	461	
Catv	179	8.7	3,469	6.8	2.7	193	296	
Telco	150	7.2	2,692	5.3	2.1	150	347	
Pole	265	12.8	5,318	10.4	4.1	296	3,067	
Municipal	20	1.0	29	0.1	0.0	2	114	
<Undefined>	0	0.0	0	0.0	0.0	0	10	
Totals:	2,067	100.0	51,034	100.0	39.5	2,838	5,625	

Detailed Load Components:

Power	Owner	Height (ft)	Horiz. Offset (in)	Cable Diameter (in)	Sag at Max Temp (ft)	Cable Weight (lbs/ft)	Lead/Span Length (ft)	Span Angle (deg)	Wire Length (ft)	Tension (lbs)	T N
Primary	AAC 477.0 KCM 19 STRAND AAC 160mil CVRD TW 6-117	NGrid	35.83	28.37	1.0420	0.637	97.8	0.0	97.8		
Primary	AAC 477.0 KCM 19 STRAND AAC 160mil CVRD TW 6-117	NGrid	35.83	18.37	1.0420	0.637	97.8	0.0	97.8		
Primary	AAC 477.0 KCM 19 STRAND AAC 160mil CVRD TW 6-117	NGrid	34.99	23.37	1.0420	0.637	97.8	0.0	97.8		
Primary	AAC 477.0 KCM 19 STRAND AAC 160mil CVRD TW 6-117	NGrid	35.83	28.37	1.0420	0.637	90.3	181.0	90.3		
Primary	AAC 477.0 KCM 19 STRAND AAC 160mil CVRD TW 6-117	NGrid	35.83	18.37	1.0420	0.637	90.3	181.0	90.3		
Primary	AAC 477.0 KCM 19 STRAND AAC 160mil CVRD TW 6-117	NGrid	34.99	23.37	1.0420	0.637	90.3	181.0	90.3		
Secondary	TRIPLEX 1/0 10-5	NGrid	29.50	7.31	1.0300	1.19	0.399	97.8	0.0	97.8	1,065
Secondary	TRIPLEX 1/0 10-5	NGrid	29.50	7.31	1.0300	1.08	0.399	90.3	181.0	90.3	1,065
Secondary	TRIPLEX 4 AWG	NGrid	29.38	60.32	0.6800	0.29	0.164	27.3	245.0	27.3	558
Overlashed Bundle	477KCM Spacer: 1/0, 2/5 AWAC 16-31	NGrid	36.66	23.37	0.5410	0.58	0.428	97.8	0.0	97.8	6,009
Overlashed Bundle	477KCM Spacer: 1/0, 2/5 AWAC 16-31	NGrid	36.66	23.37	0.5410	0.50	0.428	90.3	181.0	90.3	6,009
Totals:											

Pole Buckling

Buckling Constant	Buckling Column Height* (ft)	Buckling Section Height (% Buckling Col. Hgt.)	Buckling Section Diameter (in)	Minimum Buckling Diameter at GL (in)	Diameter at Tip (in)	Diameter at GL (in)	Modulus of Elasticity (psi)	Pole Density (pcf)	Ice Density (pcf)	Pole Tip Height (ft)
2.00	23.90	33.33	12.27	7.32	7.96	13.25	2.13e+6	60.00	57.00	43.00

Comm	Owner	Height (ft)	Horiz. Offset (in)	Cable Diameter (in)	Sag at Max Temp (ft)	Cable Weight (lbs/ft)	Lead/Span Length (ft)	Span Angle (deg)	Wire Length (ft)	Tension (lbs)
Overlashed Bundle	Fiber	23.50	7.68	0.2500	0.37	0.121	97.8	0.0	97.8	1,663
Fiber	Fiber	23.45	7.68	1.0000		0.046	97.8	0.0	97.8	
Overlashed Bundle	Fiber	23.50	7.68	0.2500	0.32	0.121	90.3	181.0	90.3	1,663
Fiber	Fiber	23.45	7.68	1.0000		0.046	90.3	181.0	90.3	
Overlashed Bundle	Fiber	22.50	7.74	0.2500	0.37	0.121	97.8	0.0	97.8	1,663
Fiber	Fiber	22.45	7.74	1.0000		0.046	97.8	0.0	97.8	
Overlashed Bundle	Fiber	22.50	7.74	0.2500	0.32	0.121	90.3	181.0	90.3	1,663
Fiber	Fiber	22.45	7.74	1.0000		0.046	90.3	181.0	90.3	
Overlashed Bundle	Catv	21.50	7.80	0.2500	0.52	0.121	97.8	0.0	97.8	1,663
CATV	Catv	21.43	7.80	1.5700		0.073	97.8	0.0	97.8	
Overlashed Bundle	Catv	21.50	7.80	0.2500	0.44	0.121	90.3	181.0	90.3	1,663
CATV	Catv	21.43	7.80	1.5700		0.073	90.3	181.0	90.3	
Overlashed Bundle	Telco	20.50	7.86	0.2500	0.76	0.121	97.8	0.0	97.8	1,663
Telco	Telco	20.45	7.86	1.0000		0.700	97.8	0.0	97.8	
Overlashed Bundle	Telco	20.50	7.86	0.2500	0.65	0.121	90.3	181.0	90.3	1,663
Telco	Telco	20.45	7.86	1.0000		0.700	90.3	181.0	90.3	
Totals:										

Streetlight	Owner	Height (ft)	Horiz. Offset (in)	Offset Angle (deg)	Rotate Angle (deg)	Unit Weight (lbs)	Unit Height (in)	Unit Depth (in)	Unit Diameter (in)	L
General	Municipal	28.50	4.87	93.0	93.0	60.00	48.00	20.00	3.00	
Streetlight - 6 ft. Arm										

Insulator	Owner	Height (ft)	Horiz. Offset (in)	Offset Angle (deg)	Rotate Angle (deg)	Unit Weight (lbs)	Unit Diameter (in)	Unit Length (in)	
Davit	NGrid	36.66	0.00	90.0	0.0	8.99	3.00	14	
16-101 477KCM 2/5 AWAC									
Bolt		29.50	0.00	90.0	0.0	5.00	3.00	0	
Single Bolt									
Bolt	Fiber	23.50	0.00	90.0	0.0	5.00	3.00	0	
Three Bolt 1.0"									
Bolt	Fiber	22.50	0.00	90.0	0.0	5.00	3.00	0	
Three Bolt 1.0"									
Bolt	Catv	21.50	0.00	90.0	0.0	5.00	3.00	0	
Three Bolt 1.5"									
Bolt	Telco	20.50	0.00	90.0	0.0	5.00	3.00	0	
Three Bolt 1.0"									
Totals:									



KIMBERLEY DRISCOLL
MAYOR

TOM DANIEL, AICP
DIRECTOR

CITY OF SALEM, MASSACHUSETTS

DEPARTMENT OF PLANNING AND COMMUNITY DEVELOPMENT

98 WASHINGTON STREET ♦ SALEM, MASSACHUSETTS 01970
TELE: 978-619-5685

MEMO

To: Mason Wells, Staff Planner
From: Patti Kelleher, Preservation Planner
Date: April 22, 2021
RE: Request for Grant of Location for Cell Antenna Attachment

I have reviewed the request from Verizon Wireless for the installation of a cell attachment to an existing telephone pole at 204 Lafayette Street. As part of the review for cell attachments, a determination must be made that the attachments will not impact the city's historic resources. Therefore, I have reviewed the submitted plans and offer the following comment:

- The subject light pole is directly in front of the historic Henry M. Batchelder House (SAL.1988), one of the finest examples of the Colonial Revival style on Lafayette Street. Constructed immediately after the Great Salem Fire of 1914, the building was designed by Little and Brown, a major Boston architectural firm, for the president of the Merchant's National Bank in Salem. While this building is located just outside of the Lafayette Street Local Historic District and is not listed in the National Register, the building has been inventoried and is likely eligible for National Register listing due to its architectural and historical significance.

Based on the above finding, I recommend an alternative location be selected to minimize impacts on the adjacent historic resource. If an alternative location cannot be used, then the pole mounted equipment should be placed as high as possible on the pole (it is currently positioned at 8' above grade). The attachments should also be painted to match the color and finish of the telephone pole. The Historical Commission often requires property owners to paint vents and pipes in a finish to match color of building.



CITY OF SALEM, MASSACHUSETTS

Kimberley Driscoll
Mayor

Office of the Mayor

June 10, 2021

Honorable Salem City Council
Salem City Hall
Salem, Massachusetts 01970

Ladies and Gentlemen of the City Council:

I am pleased to appoint Attorney Carly McClain of 22 Albion Street to the Zoning Board of Appeals to a five year term to expire June 10, 2026. Attorney McClain will take the seat previously occupied by Jimmy Tsitsinos. Please join me in thanking Mr. Tsitsinos for his years of service to our community on the ZBA.

Attorney McClain earned her J.D. from New England Law and holds a B.A. in Political Science from UMass-Amherst. She has served as the General Counsel of the Lynn Housing Authority and Neighborhood Development (LHAND) since 2016 and was, prior to that the organizing director for the North Shore Workers Community Fund. Attorney McClain volunteers as pro bono legal counsel for Healing Abuse Working for Change (HAWC) and on asylum cases for immigrants, as well as volunteering as a member of the Lynn Council on Aging Committee. As LHAND's Fair Housing Officer she has extensive experience with federal housing law and throughout her work she has developed a particular expertise in housing, community development, due process, and evidentiary standards for legal and judicial reviews.

I strongly recommend confirmation of Attorney McClain's appointment to the ZBA. We are fortunate that she is willing to volunteer in this important role and lend her time and expertise to this important board and its work.

Sincerely,

Kimberley Driscoll
Mayor
City of Salem



CITY OF SALEM, MASSACHUSETTS

Kimberley Driscoll
Mayor

Office of the Mayor

June 24, 2021

Honorable Salem City Council
Salem City Hall
Salem, Massachusetts 01970

Ladies and Gentlemen of the City Council:

I reappoint, subject to City Council confirmation, Kirt Rieder of 15 Warren Street to the Planning Board for a term of 5 years to expire 7/1/2026.

I recommend confirmation of this reappointment and ask that you join me in thanking Mr. Rieder for their continued dedicated service and commitment to our community.

Very truly yours,

Kimberley Driscoll
Mayor
City of Salem



CITY OF SALEM, MASSACHUSETTS

Kimberley Driscoll
Mayor

Office of the Mayor

June 24, 2021

Honorable Salem City Council
Salem City Hall
Salem, Massachusetts 01970

Ladies and Gentlemen of the City Council:

I reappoint, subject to City Council confirmation, Mark Pattison of 2 Beaver Street to the Historical Commission for a term of 3 years to expire 6/28/2024.

I recommend confirmation of this reappointment and ask that you join me in thanking Mr. Pattison for their continued dedicated service and commitment to our community.

Very truly yours,

Kimberley Driscoll
Mayor
City of Salem



CITY OF SALEM, MASSACHUSETTS
Kimberley Driscoll
Mayor

June 24, 2021

Honorable Salem City Council
Salem City Hall
Salem, Massachusetts 01970

Ladies and Gentlemen of the City Council:

I am pleased to inform you that I have appointed Ziggy Hartfelder and Melissa Stockbridge for three years terms each to the Salem Cultural Council, to expire June 9, 2024. This letter is being provided to you for informational purposes, as no City Council confirmation is required for this appointment.

Ms. Hartfelder is the owner of Irish Eye Photography, which she has operated for the last two decades. She has extensive experience in the arts as a photographer, producer, event organizer, and curator. She is a member of the Salem Arts Association and an award-winning photographer. Ms. Stockbridge works as a program manager for Tufts University in their technology services office where she has been a key team member for such projects as the university's recent School of the Museum of Fine Arts merger initiative. Locally, Ms. Stockbridge volunteers as the board president for the Woman's Friend Society.

I hope you will join me in welcoming both Ms. Hartfelder and Ms. Stockbridge to the Salem Cultural Council. We are fortunate that they are willing to volunteer in this important role and lend their commitment and energy to the council and its work.

Sincerely,

Kimberley Driscoll
Mayor
City of Salem

CC: Ziggy Hartfelder
Melissa Stockbridge
Julie Barry, Senior Planner for Arts & Culture
John Dobroski, Salem Cultural Council chair



CITY OF SALEM

In City Council,

June 24, 2021

Ordered:

That the sum of Twenty-Four Thousand Two Hundred Thirty Dollars and Seventy Cents (\$24,230.70) is hereby transferred from the "Retained Earnings – Water/Sewer Fund" account (6000-3120) to the DPS Water Contracted Services account (610032-5320) as provided below to fund the costs for the repair of a water main break February 18, 2021 on Loring Avenue in accordance with the recommendation of Her Honor the Mayor.

Description	Fund	Amount
DPW Water Contracted Services	610032-5320	\$ 24,230.70
		\$ 24,230.70



CITY OF SALEM, MASSACHUSETTS

Kimberley Driscoll

Mayor

June 24, 2021

To the City Council
City Hall
Salem, Massachusetts

Ladies and Gentlemen of the Council:

Enclosed herewith is a request for an appropriation of Twenty-Four Thousand Two Hundred Thirty Dollars and Seventy Cents (\$24,230.70) from the Retained Earnings – Water/Sewer Fund” account (6000-3120) to the DPS Water Contracted Services account (610032-5320).

This appropriation is necessary to cover the costs for the repair of a water main break on February 18, 2021, on Loring Avenue.

I recommend passage of the accompanying Order.

Very truly yours,

A handwritten signature in black ink, appearing to read "Kim Driscoll", is written over the printed name.

Kimberley Driscoll

Mayor



Kimberley Driscoll
Mayor

CITY OF SALEM
SALEM, MASSACHUSETTS
ENGINEERING DEPARTMENT
98 WASHINGTON STREET, 2ND FLOOR
SALEM, MA 01970
Phone: (978) 619-5673
Fax: (978) 745-0349

DAVID H. KNOWLTON, P.E.
CITY ENGINEER / DPS DIRECTOR

MEMORANDUM

April 25, 2021

To: Dominick Pangallo, Chief Administrative Aide to the Mayor
From: David H. Knowlton, P.E., City Engineer / DPS Director *David*
RE: Request to Transfer \$24,230.70 from Water/Sewer Enterprise Retained Earnings

This memo has been prepared to request a transfer of funds from the Water/Sewer Enterprise Retained Earnings to fund the costs for the repair of a water main break on February 18, 2021 on Loring ave

The cost of the transfer is as follows, and are detailed as an attachment to this memo:

<u>Description</u>	<u>Amount</u>
N. Granese & Sons, Inc. - break repair	\$22,358.70
Police Details	<u>\$1,872.00</u>
	\$24,230.70

The funds should be transferred to the DPS Water, Contracted Services budget line, 610032-5320, for payment of the attached invoices.

If you have any questions, or require additional information, please call. The DPS Department is available to meet with the City Council to discuss this request.

Cc: Laurie Giardella, Finance Director



CITY OF SALEM

In City Council,

Ordered:

June 24, 2021

That the sum of Twenty-One Thousand Nine Hundred Ninety-Two Dollars and Ten Cents (\$21,992.10) be approved within the "Retirement Stabilization Fund-Vacation/Sick Leave Buyback" account (83113-5146) to be expended for the FY 2021 contractual buyback(s) listed below in accordance with the recommendation of Her Honor the Mayor.

Name	Department	Amount
Marcia Kirkpatrick	Public Property	\$ 21,992.10
		\$ 21,992.10



CITY OF SALEM, MASSACHUSETTS

Kimberley Driscoll

Mayor

June 24, 2021

To the City Council
City Hall
Salem, Massachusetts

Ladies and Gentlemen of the Council:

Enclosed herewith is a request for an appropriation of Twenty-One Thousand Nine Hundred Ninety-Two Dollars and Ten Cents (\$21,992.10) appropriated within the "Retirement Stabilization Fund-Vacation/Sick Leave Buyback" account (83113-5146).

This transfer is necessary to fund the retirement buyback for Public Property employee.

Name	Department	Amount
Marcia Kirkpatrick	Public Property	\$21,992.10
	TOTAL:	\$21,992.10

I recommend passage of the accompanying Order.

Very truly yours,

A handwritten signature in black ink, appearing to read "Kim Driscoll", written over the printed name.

Kimberley Driscoll
Mayor



CITY OF SALEM, MASSACHUSETTS

HUMAN RESOURCES
120 WASHINGTON STREET
TEL. (978) 745-9595 EXT. 5630
FAX (978) 745-7298

KIMBERLEY DRISCOLL
MAYOR

LISA B. CAMMARATA
DIRECTOR OF HUMAN RESOURCES

MEMORANDUM

TO: Anna Freedman, Director of Finance
DATE: June 7, 2021
RE: Retirement Stabilization Fund

Attached you will find a retirement buy back for a former employee of the Public Property Department.

This former employee is entitled to the following amount of vacation and sick leave buyback.

Marcia Kirkpatrick

Table with 2 columns: Description and Amount. Rows include 142.9165 vacation hours @ \$28.4534 per hour (\$4,066.46), 630 sick hours @ \$28.4534 per hour (\$17,925.64), and Total (\$21,992.10).

In accordance with the July 2008 Policy, I am requesting you verify the availability of the funds from the Retirement Stabilization Fund, prepare the Council Order, and continue the process in order that my staff can input the information in MUNIS and issue payments to this former employee upon Council approval.

Thank you for your cooperation, and if you should have any questions, please do not hesitate to contact me.

Handwritten signature of Lisa B. Cammarata



CITY OF SALEM

PART A

THIS FORM CANNOT BE PROCESSED UNLESS ALL SHADED AREAS AND PERTINENT INFORMATION IS SUPPLIED
PERSONNEL ACTION / DATA FORM

DATE 5/24/21

NAME (LAST, FIRST, MIDDLE) <i>Kirkpatrick Maccia</i>		EMPLOYEE NO. <i>10/501</i>	CHECK ALL THAT APPLY 1. EMPLOYMENT () 2. WAGE SALARY ADJUSTMENT () 3. TRANSFER () 4. LEAVE OF ABSENCE () 5. ADDRESS/NAME CHANGE () 6. TERMINATION () 7. OTHER ()
JOB TITLE <i>Principal Acct. Clerk</i>		JOB CODE <i>1239</i>	
DEPARTMENT <i>Building</i>	DIVISION	DEPT. NO. <i>1222</i>	

1. EMPLOYMENT

ADDRESS-STREET	CITY	STATE	ZIP CODE	SOCIAL SECURITY NO.	NEW HIRE	REHIRE	RECALL	Salaried Hourly				
PERMANENT 1. Full Time 2. 20 HRS.+ Part Time 3. Part Time	4. TEMP	CIVIL SERVICE YES NO	DATE APPROVED	VETERAN YES NO	SHIFT	PAY RATE \$	PER	SHIFT PREM.	Grade	Step		
TELEPHONE NO.	DATE OF BIRTH	SEX M F	ETHNIC CODE	SCHEDULED HOURS	HOURLY RATE	# DEPENDENTS	MARITAL STATUS M S OTHER	REQUIRED LICENSE:TYPE(S)			CLASS	EXPIRATION DATE

2. WAGE / SALARY ADJUSTMENT (GIVE EXPLANATION IN SEC. 8)

ANNIVERSARY DATE	DATE OF LAST INCREASE	PRESENT RATE PER	PROPOSED RATE PER	NEW HOURLY RATE	GRADE	STEP	EFFECTIVE DATE
------------------	-----------------------	------------------	-------------------	-----------------	-------	------	----------------

3. TRANSFER-JOB, SHIFT, DEPT. (GIVE EXPLANATION IN SEC. 8)

NEW DEPT. & NO.	NEW JOB TITLE	NEW JOB CODE	RATE CHANGE: YES NO
NEW GRADE	NEW STEP	NEW PAY RATE PER	EFFECTIVE DATE
SHIFT CHANGE:		FROM	TO

4. LEAVE OF ABSENCE (GIVE EXPLANATION IN SEC. 8)

FROM	TO	DATE RETURNED
------	----	---------------

5. ADDRESS / NAME CHANGE

NEW ADDRESS	STREET	CITY	STATE	ZIP CODE	NEW TELEPHONE NO.	CORRECT NAME TO
-------------	--------	------	-------	----------	-------------------	-----------------

6. TERMINATION (GIVE EXPLANATION IN SEC. 8)

LAST DAY WORKED	DATE HIRED	RECOMMENDED FOR REEMPLOYMENT	YES	NO	
REASON RE-SIGNED LAID OFF END OF RE-TEMP. TIRE DIS-CHARGED		QUALITY OF WORK EXCEL GOOD FAIR POOR	ATTENDANCE EXCEL GOOD FAIR POOR	ATTITUDE EXCEL GOOD FAIR POOR	JOB KNOWLEDGE EXCEL GOOD FAIR POOR

7. EMERGENCY CONTACT

NAME:	TELEPHONE NO.	RELATIONSHIP
-------	---------------	--------------

8. EXPLANATION OF ACTION (or other action)

Retired - June 4, 2021

FINANCE DEPARTMENT DATE

DEPARTMENT HEAD / APPOINTING AUTHORITY DATE

PERSONNEL DEPARTMENT DATE *5/25/21*

[Signature]
[Signature]
019/2021

CITY OF SALEM
APPROVAL-SICK DAYS/VACATION BUY-BACK

From: Department Building Dept Date 5/24/21
Authorized Signature: [Signature] 5/25/21
Department Head/City or Business Manager/School

NAME: Marcia Kirkpatrick

CALCULATION

VACATION HOURS # 142,9165 @ \$ 28.4534 = \$ 4,066.46
SICK HOURS # 630 @ \$ 28.4534 = \$ 17,925.64
PRO-RATED STIPENDS # _____ @ \$ _____ = \$ _____
OTHER # _____ @ \$ _____ = \$ _____

Total Amount Due: \$ 21,992.10
Please attach corresponding PAF or other backup to this sheet.

Reason: Retirement - 6/4/21

For Human Resources's Use Only:

- VACATION HOURS
- SICK HOURS
- PER ACCRUAL REPORT
- OTHER

Org and Object: 83113 - 5146

Recommendation:

Approved

[Signature]
H R Director/City or Superintendent/Schools



CITY OF SALEM

In City Council,

Ordered:

June 24, 2021

That the sum of Eighteen Thousand Four Hundred Forty-Seven Dollars and Twenty Cents (\$18,447.20) is hereby transferred from the "Retained Earnings – Water/Sewer Fund" account (6000-3120) to the DPS Water Contracted Services account (610032-5320) as provided below to fund the costs for the repair of a water main break on February 15, 2021 on Highland Avenue in accordance with the recommendation of Her Honor the Mayor.

Description	Fund	Amount
DPW Water Contracted Services	610032-5320	\$ 18,447.20
		\$ 18,447.20



CITY OF SALEM, MASSACHUSETTS
Kimberley Driscoll
Mayor

June 24, 2021

To the City Council
City Hall
Salem, Massachusetts

Ladies and Gentlemen of the Council:

Enclosed herewith is a request for an appropriation of Eighteen Thousand Four Hundred Forty-Seven Dollars and Twenty Cents (\$18,447.20) from the Retained Earnings – Water/Sewer Fund” account (6000-3120) to the DPS Water Contracted Services account (610032-5320).

This appropriation is necessary to cover the costs for the repair of a water main break on February 15, 2021 on Highland Avenue.

I recommend passage of the accompanying Order.

Very truly yours,

Kimberley Driscoll
Mayor



Kimberley Driscoll
Mayor

CITY OF SALEM
SALEM, MASSACHUSETTS
ENGINEERING DEPARTMENT
98 WASHINGTON STREET, 2ND FLOOR
SALEM, MA 01970
Phone: (978) 619-5673
Fax: (978) 745-0349

DAVID H. KNOWLTON, P.E.
CITY ENGINEER / DPS DIRECTOR

MEMORANDUM

April 25, 2021

To: Dominick Pangallo, Chief Administrative Aide to the Mayor
From: David H. Knowlton, P.E., City Engineer / DPS Director *David*
RE: Request to Transfer \$18,447.20 from Water/Sewer Enterprise Retained Earnings

This memo has been prepared to request a transfer of funds from the Water/Sewer Enterprise Retained Earnings to fund the costs for the repair of a water main break on February 15, 2021 on Highland ave.

The cost of the transfer is as follows, and are detailed as an attachment to this memo:

<u>Description</u>	<u>Amount</u>
N. Granese & Sons, Inc. - break repair	\$17,295.20
Police Details	<u>\$1,152.00</u>
	\$18,447.20

The funds should be transferred to the DPS Water, Contracted Services budget line, 610032-5320, for payment of the attached invoices.

If you have any questions, or require additional information, please call. The DPS Department is available to meet with the City Council to discuss this request.

Cc: Laurie Giardella, Finance Director



CITY OF SALEM

In City Council,

Ordered:

June 24, 2021

That the sum of Seventeen Thousand Five Hundred Ninety-Six Dollars and Seventy-Five Cents (\$17,596.75) is hereby transferred from the "Retained Earnings – Water/Sewer Fund" account (6000-3120) to the DPS Water Contracted Services account (610032-5320) as provided below to fund the costs for the repair of a water main break on April 28, 2021, on 98 Broadway Street in accordance with the recommendation of Her Honor the Mayor.

Description	Fund	Amount
DPW Water Contracted Services	610032-5320	\$ 17,596.75
		\$ 17,596.75



CITY OF SALEM, MASSACHUSETTS
Kimberley Driscoll
Mayor

June 24, 2021

To the City Council
City Hall
Salem, Massachusetts

Ladies and Gentlemen of the Council:

Enclosed herewith is a request for an appropriation of Seventeen Thousand Five Hundred Ninety-Six Dollars and Seventy-Five Cents (17,596.75) from the Retained Earnings – Water/Sewer Fund” account (6000-3120) to the DPS Water Contracted Services account (610032-5320).

This appropriation is necessary to cover the costs for the repair of a water main break on April 28, 2021, on 98 Broadway Street.

I recommend passage of the accompanying Order.

Very truly yours,

Kimberley Driscoll
Mayor



Kimberley Driscoll
Mayor

CITY OF SALEM
SALEM, MASSACHUSETTS
ENGINEERING DEPARTMENT
98 WASHINGTON STREET, 2ND FLOOR
SALEM, MA 01970
Phone: (978) 619-5673
Fax: (978) 745-0349

DAVID H. KNOWLTON, P.E.
CITY ENGINEER / DPS DIRECTOR

MEMORANDUM

May 3, 2021

To: Dominick Pangallo, Chief Administrative Aide to the Mayor
From: David H. Knowlton, P.E., City Engineer / DPS Director *David*
RE: Request to Transfer \$17596.75 from Water/Sewer Enterprise Retained Earnings

This memo has been prepared to request a transfer of funds from the Water/Sewer Enterprise Retained Earnings to fund the costs for the repair of a water main break on April 28, 2021 on 98 Broadway Street.

The cost of the transfer is as follows, and are detailed as an attachment to this memo:

<u>Description</u>	<u>Amount</u>
N. Granese & Sons, Inc. - break repair	\$15,191.00
Materials	\$1,109.75
Police Details	<u>\$1,296.00</u>
	<u>\$17,596.75</u>

The funds should be transferred to the DPS Water, Contracted Services budget line, 610032-5320, for payment of the attached invoices.

If you have any questions, or require additional information, please call. The DPS Department is available to meet with the City Council to discuss this request.

Cc: Laurie Giardella, Finance Director

CITY OF SALEM – Finance Department
Free Cash, W & S R/E, R/Res & Budget Transfer Request Form

From: 230 – Department of Public Services
 Department

Knowlton 
 Dept. Head Authorizing Signature

5-3-21
 Date

Budget or R/Res

Budget Amt: _____

Transfers To : _____ Desc: _____ Balance: _____
 (Org/Object)

Budget Amt: _____

From : _____ Desc: _____ Balance: _____
 (*Note - Please include letter to Mayor for Transfers from different Personnel & Non-personnel lines)

Current Balance in Receipts Reserved Fund Above (if applicable) - \$ _____ Date: _____

Free Cash or To: 610032-5320
 Retained Earnings (W/S) (Org/Object)

Desc: Contracted Services

Budget Amt: \$1,000
 Balance: \$0

Raise & Appropriate
 Please circle one

Amount Requested: \$17,596.75

Reason (Be Specific) See Attached

For Finance Department and Mayor's Use Only:

Budget Transfer Mayor Approval City Council Approval

Free Cash Appropriation – City Council Approval – Gen Fund \$ _____
 Free Cash Balance

R/E Appropriation –Water \$ 301,226 R/E Appropriation Sewer \$ _____
 R/E Balance R/E Balance

Receipts Reserve – City Council Approval \$ _____
 R/Res Fund Balance

Raise & Appropriate Other _____

Recommendation: Approved Denied

 Finance Director

Completed: Date: _____ By: _____ CO # _____ JE#: _____ Transfer #: _____



CITY OF SALEM

In City Council,

June 24, 2021

Ordered:

That the sum of Fifteen Thousand Seven Hundred Fifty-One Dollars and Sixty Cents (\$15,751.60) is hereby transferred from the "Retained Earnings – Water/Sewer Fund" account (6000-3120) to the DPS Water Contracted Services account (610032-5320) as provided below to fund the costs for the repair of a water main break February 2, 2021, on DiPietro Lane in accordance with the recommendation of Her Honor the Mayor.

Description	Fund	Amount
DPW Water Contracted Services	610032-5320	\$ 15,751.60
		\$ 15,751.60



CITY OF SALEM, MASSACHUSETTS
Kimberley Driscoll
Mayor

June 24, 2021

To the City Council
City Hall
Salem, Massachusetts

Ladies and Gentlemen of the Council:

Enclosed herewith is a request for an appropriation of Fifteen Thousand Seven Hundred Fifty-One Dollars and Sixty Cents (\$15,751.60) from the Retained Earnings – Water/Sewer Fund” account (6000-3120) to the DPS Water Contracted Services account (610032-5320).

This appropriation is necessary to cover the costs for the repair of a water main break on February 2, 2021, on DiPietro Lane.

I recommend passage of the accompanying Order.

Very truly yours,

Kimberley Driscoll
Mayor



Kimberley Driscoll
Mayor

CITY OF SALEM
SALEM, MASSACHUSETTS
ENGINEERING DEPARTMENT
98 WASHINGTON STREET, 2ND FLOOR
SALEM, MA 01970
Phone: (978) 619-5673
Fax: (978) 745-0349

DAVID H. KNOWLTON, P.E.
CITY ENGINEER / DPS DIRECTOR

MEMORANDUM

April 25, 2021

To: Dominick Pangallo, Chief Administrative Aide to the Mayor
From: David H. Knowlton, P.E., City Engineer / DPS Director *David*
RE: Request to Transfer \$15,751.60 from Water/Sewer Enterprise Retained Earnings

This memo has been prepared to request a transfer of funds from the Water/Sewer Enterprise Retained Earnings to fund the costs for the repair of a water main break on February 2, 2021 on DiPietro Lane.

The cost of the transfer is as follows, and are detailed as an attachment to this memo:

<u>Description</u>	<u>Amount</u>
N. Granese & Sons, Inc. - break repair	\$14,455.60
Police Details	<u>\$1,296.00</u>
	\$15,751.60

The funds should be transferred to the DPS Water, Contracted Services budget line, 610032-5320, for payment of the attached invoices.

If you have any questions, or require additional information, please call. The DPS Department is available to meet with the City Council to discuss this request.

Cc: Laurie Giardella, Finance Director

CITY OF SALEM – Finance Department
Free Cash, W & S R/E, R/Res & Budget Transfer Request Form

From: 230 – Department of Public Services
Department

Knowlton 
Dept. Head Authorizing Signature

4-25-21
Date

Budget or R/Res

Budget Amt: _____

Transfers To : _____
(Org/Object)

Desc: _____ Balance: _____

Budget Amt: _____

From : _____ Desc: _____ Balance: _____

(*Note - Please include letter to Mayor for Transfers from different Personnel & Non-personnel lines)

Current Balance in Receipts Reserved Fund Above (if applicable) - \$ _____ Date: _____

Free Cash or To: 610032-5320
Retained Earnings (W/S) (Org/Object)

Desc: Contracted Services

Budget Amt: \$1,000

Balance: \$0

Raise & Appropriate

Please circle one

Amount Requested: \$15,751.60

Reason (Be Specific) See Attached

For Finance Department and Mayor's Use Only:

_____ Budget Transfer _____ Mayor Approval _____ City Council Approval

_____ Free Cash Appropriation – City Council Approval – Gen Fund \$ _____
Free Cash Balance

R/E Appropriation – Water \$ 301,226 _____ R/E Appropriation Sewer \$ _____
R/E Balance R/E Balance

_____ Receipts Reserve – City Council Approval \$ _____
R/Res Fund Balance

_____ Raise & Appropriate _____ Other _____

Recommendation: _____ Approved _____ Denied



 Finance Director

Completed: Date: _____ By: _____ CO # _____ JE#: _____ Transfer #: _____



CITY OF SALEM

In City Council,

Ordered:

June 24, 2021

That the sum of Nine Thousand Two Hundred Six Dollars and Ninety-Six Cents (\$9,206.96) is hereby transferred from the Purchasing Department's "Part-Time Salaries" account (11381-5113) to the Purchasing Department's "Telephone-Wireless" account as provided below to cover remaining payments for cell and wireless device usage for FY2021 in accordance with the recommendation of Her Honor the Mayor.

Description	Fund	Amount
Telephone-Wireless	11392-5341	\$ 9,206.96
		\$ 9,206.96



CITY OF SALEM, MASSACHUSETTS
Kimberley Driscoll
Mayor

June 24, 2021

To the City Council
City Hall
Salem, Massachusetts

Ladies and Gentlemen of the Council:

Enclosed herewith is a request to transfer Nine Thousand Two Hundred Six Dollars and Ninety-Six Cents (\$9,206.96) from the Purchasing Department's "Part-Time Salaries" account (11381-5113) to the Purchasing Department's "Telephone -Wireless" account as provided below to cover remaining payments for cell and wireless device usage for FY 2021.

This transfer is necessary to cover remaining payments for cell and wireless device usage for FY 2021.

Very truly yours,

Kimberley Driscoll
Mayor



CITY OF SALEM, MASSACHUSETTS

PURCHASING DEPARTMENT
93 WASHINGTON STREET, 3RD FLOOR
SALEM, MA 01970
TEL. (978) 619-5696
TWATLKINS@SALEM.COM

KIMBERLEY DRISCOLL
MAYOR

THOMAS P. WATKINS
PURCHASING
AGENT

June 14, 2021

The Honorable Mayor Kimberley Driscoll
City of Salem
93 Washington Street
Salem, MA 01970

Subject: Part Time Salaries – Telephone Wireless

Dear Mayor Driscoll:

We respectfully request an appropriation of funds in the amount of Nine Thousand Two Hundred Six and 96/100th (\$9,206.96) from the following account:

11381-5113 – Part Time Salaries - \$9,206.96

to be transferred into Telephone – Wireless account – 11392-5341. This appropriation will allow for past due and end of the year payments to T-Mobile, ATT FirstNet, and Verizon. The past due balances for April and May total \$5,830.63. Additionally, we expect invoices for the above providers in June to total approximately \$2,900.00.

Respectfully yours,

A handwritten signature in black ink, appearing to read "Anna Freedman".

Anna Freedman, Finance Director
on behalf of the Purchasing Department

CITY OF SALEM – Finance Department

Free Cash, W & S R/E, R/Res & Budget Transfer Request Form

From: Purchasing Department
 Department Head Authorizing Signature _____ Date _____

Budget or R/Res Transfers
 To: 11392-5341 (Org/Object) Desc: Telephone Wireless Budget Amt: \$ 36,500.00
 Balance: 100
 From: 11381-513 Desc: PT Salaries Budget Amt: \$ 9,206.96
 Balance: \$ 9,206.96
 (*Note - Please include letter to Mayor for Transfers from different Personnel & Non-personnel lines)
 Current Balance in Receipts Reserved Fund Above (if applicable) - \$ _____ Date: _____

Free Cash or Retained Earnings (W/S) To: _____ Desc: _____ Budget Amt: _____
 (Org/Object) Balance: _____
Raise & Appropriate
 Please circle one

Amount Requested: \$ 9,206.96
Reason (Be Specific) Add'l funds for Wireless telephones - T-Mobile AT&T. Past due balance for April & May is \$5830.63. Expected invoices for June total approx: \$3400.00

For Finance Department and Mayor's Use Only:

- Budget Transfer _____ Mayor Approval _____ City Council Approval
- _____ Free Cash Appropriation – City Council Approval – Gen Fund \$ _____
 Free Cash Balance
- _____ R/E Appropriation – Water \$ _____ R/E Balance _____ R/E Appropriation Sewer \$ _____
 R/E Balance R/E Balance
- _____ Receipts Reserve – City Council Approval \$ _____
 R/Res Fund Balance
- _____ Raise & Appropriate _____ Other _____

Recommendation: _____ Approved _____ Denied



 Finance Director

Completed: Date: _____ By: _____ CO # _____ JE#: _____ Transfer #: _____



CITY OF SALEM

In City Council,

Ordered:

June 24, 2021

That the sum of Nine Thousand, Fifty Dollars (\$9,050.00) is hereby appropriated in the "Retirement Stabilization Fund-Vacation/Sick Leave Buyback" account (83113-5146) to be expended for the negotiated two-day sick leave buyback provision as needed in accordance with the recommendation of Her Honor the Mayor.



CITY OF SALEM, MASSACHUSETTS
Kimberley Driscoll
Mayor

June 24, 2021

To the City Council
City Hall
Salem, Massachusetts

Ladies and Gentlemen of the Council:

Enclosed herewith is a request for an appropriation of Nine Thousand, Fifty Dollars (9,050.00) from the Retirement Stabilization Fund-Vacation/Sick Leave Buyback” account (83113-5146).

This appropriation is to be expended for the negotiated two-day sick leave buyback provision as needed.

I recommend passage of the accompanying Order.

Very truly yours,

A handwritten signature in black ink, appearing to read "Kimberley Driscoll", is written over the typed name.

Kimberley Driscoll
Mayor



KIMBERLEY L. DRISCOLL
MAYOR

LISA B. CAMMARATA
DIRECTOR OF HUMAN
RESOURCES

CITY OF SALEM MASSACHUSETTS

HUMAN RESOURCES
98 WASHINGTON STREET, 3RD FLOOR
SALEM, MASSACHUSETTS 01970
TEL. 978-619-5630
FAX 978-745-7298

June 16, 2021

Kimberley Driscoll, Mayor
City of Salem
93 Washington Street
Salem, MA 01970

RE: Retirement Stabilization

Dear Mayor Driscoll:

I am respectfully requesting the amount of Nine Thousand and Fifty dollars (\$9,050.00) be appropriated in the Retirement Stabilization Fund for sick leave buybacks submitted in accordance with collective bargaining agreements with our various unions.

Sick leave buy back to be filled under this particular appropriation request are for these active employees, not retirees, who wish to take advantage of the most recent contractual language allowing members to buyback certain amounts of unused sick leave, on a one-time basis. A lump sum request for this purpose will allow us to process those requests in a more efficient and timely manner.

Thank you for your attention and cooperation with this request, and if you have any questions, please do not hesitate to contact me.

Very truly yours,

A handwritten signature in black ink, appearing to read "Lisa B. Cammarata", with a long horizontal line extending to the right.

Lisa B. Cammarata

cc: File

CITY OF SALEM
APPROVAL-SICK DAYS/VACATION BUY-BACK

From: Department: SCHOOL

Date:

6/14/2021

Authorized Signature: _____

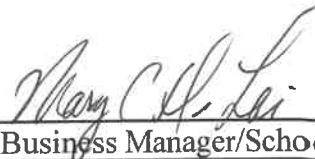

Department Head/City or Business Manager/School

NAME: Nancy Charest

CALCULATION

SICK DAYS: 45 sick days @ \$65 per day = \$2925

Total Amount Due: \$2925

Please attach corresponding PAF or other backup to this sheet.

Reason: In accordance with Article 1V, Section I entitled "Sick leave buy-back", Nancy Charest is requesting the city pay for 45 days of sick leave at the rate of \$65 per day. Nancy Charest has 76.5 days of accrued sick leave as of this date.

For Human Resources's Use Only:

SICK DAYS

PER ACCRUAL REPORT

Org and Object: 83113-5146

Recommendation:

Approved



HR Director/City or Superintendent/Schools

CITY OF SALEM
APPROVAL-SICK DAYS/VACATION BUY-BACK

From: Department: SCHOOL

Date:

6/14/2021

Authorized Signature: _____



Department Head/City or Business Manager/School

NAME: Carole Donnelly

CALCULATION

SICK DAYS: 45 sick days @ \$125 per day = \$5625

Total Amount Due: \$5625

Please attach corresponding PAF or other backup to this sheet.

Reason: In accordance with Article 1V, Section I entitled "Sick leave buy-back", Carole Donnelly is requesting the city pay for 45 days of sick leave at the rate of \$125 per day. Carole Donnelly has 107.5 days of accrued sick leave as of this date.

For Human Resources's Use Only:



SICK DAYS



PER ACCRUAL REPORT

Org and Object:

83113-5146

Recommendation:



Approved

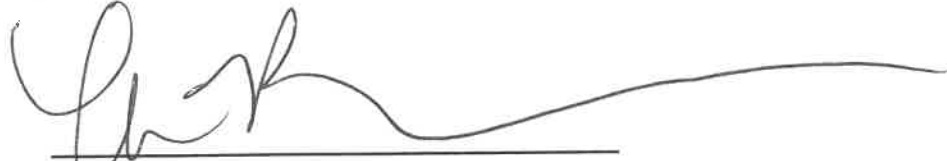

HR Director/City or Superintendent/Schools



CITY OF SALEM

In City Council,

Ordered:

June 24, 2021

That the sum of Eight Thousand One Hundred Eighty-Two Dollars and Forty Five Cents (\$8,182.45) be approved within the "Retirement Stabilization Fund-Vacation/Sick Leave Buyback" account (83113-5146) to be expended for the FY 2021 contractual buyback(s) listed below in accordance with the recommendation of Her Honor the Mayor.

Name	Department	Amount
Carmella Cote	Salem Public Schools	\$ 8,182.45
		\$ 8,182.45



CITY OF SALEM, MASSACHUSETTS

Kimberley Driscoll

Mayor

June 24, 2021

To the City Council
City Hall
Salem, Massachusetts

Ladies and Gentlemen of the Council:

Enclosed herewith is a request for an appropriation of Eight Thousand One Hundred Eighty-Two Dollars and Forty-Five Cents (\$8,182.45) appropriated within the "Retirement Stabilization Fund-Vacation/Sick Leave Buyback" account (83113-5146).

This transfer is necessary to fund the retirement buyback for School employee.

Name	Department	Amount
Carmella Cote	Salem Public Schools	\$8,182.45
	TOTAL:	\$8,182.45

I recommend passage of the accompanying Order.

Very truly yours,

Kimberley Driscoll
Mayor



CITY OF SALEM MASSACHUSETTS

**KIMBERLEY L. DRISCOLL
MAYOR**

**LISA B. CAMMARATA
DIRECTOR OF HUMAN
RESOURCES**

**HUMAN RESOURCES
98 WASHINGTON STREET, 3RD FLOOR
SALEM, MASSACHUSETTS 01970
TEL. 978-619-5630
FAX 978-745-7298**

MEMORANDUM

TO: Anna Freedman, Director of Finance
DATE: May 12, 2021
RE: Retirement Stabilization Fund

Attached you will find a retirement buy back for a former employee of the Salem Public Schools.

This former employee is entitled to the following amount of sick leave and vacation buyback.

Carmella Cote

27 vacation hours @ \$22.07 per hour	\$595.89
343.75 sick hours @ \$22.07 per hour	\$7,586.56
Total:	\$8,182.45

In accordance with the July 2008 Policy, I am requesting you verify the availability of the funds from the Retirement Stabilization Fund, prepare the Council Order, and continue the process in order that my staff can input the information in MUNIS and issue payments to this former employee upon Council approval.

Thank you for your cooperation, and if you should have any questions, please do not hesitate to contact me.

CITY OF SALEM
APPROVAL-SICK DAYS/VACATION BUY-BACK

From: Department School

Date 5/4/2021

Authorized Signature: [Signature]
Department Head/City or Business Manager/School

NAME: Carmella Cote

CALCULATION

Hours
VACATION DAYS # 27 @ \$ 22.07 = \$ 595.89

Hours
SICK DAYS # 343.75 @ \$ 22.07 = \$ 7,586.56

PRO-RATED STIPENDS # _____ @ \$ _____ = \$ _____

OTHER # _____ @ \$ _____ = \$ _____

Total Amount Due: \$ 8,182.45
Please attach corresponding PAF or other backup to this sheet.

Reason: Retirement

For Human Resources's Use Only:

- VACATION DAYS
- SICK DAYS
- PER ACCRUAL REPORT
- OTHER

Org and Object: 83113 - 5/46

Recommendation:
 Approved
[Signature]
H R Director/City or Superintendent/Schools



CITY OF SALEM

In City Council,

Ordered:

June 24, 2021

That the sum of Six Thousand Dollars (\$6,000.00) is hereby transferred from the Assessing Department's "FT Salaries" account (11411-5111) to the Assessing Department's "Contracted Services" account as provided below to cover payment associated with temporary contract assessing services for FY2021 in accordance with the recommendation of Her Honor the Mayor.

Description	Fund	Amount
Contracted Services	11412-5308	\$ 6,000.00
		\$ 6,000.00



CITY OF SALEM, MASSACHUSETTS
Kimberley Driscoll
Mayor

June 24, 2021

To the City Council
City Hall
Salem, Massachusetts

Ladies and Gentlemen of the Council:

Enclosed herewith is a request to transfer Six Thousand Dollars (\$6,000.00) from the "Assessing Department's FT Salaries account (11411-5111) to the Assessing Department's "Contracted Services" account.

Description	Fund	Amount
Contracted Services	11412-5308	\$6,000.00

This transfer is necessary to cover payment associated with temporary contract assessing services for FY 2021.

Sincerely,

A handwritten signature in black ink that reads "Kim Driscoll".

Kimberley Driscoll
Mayor

**CITY OF SALEM, MASSACHUSETTS
ASSESSING DEPARTMENT**

**93 WASHINGTON STREET
SALEM, MA 01970
TEL. 978-745-9595
FAX. 978-744-2069**

**MAYOR
KIMBERLEY DRISCOLL**

**ACTING DIRECTOR
STEPHEN CORTES**

**BOARD MEMBERS
ROBERT MILLERICK
RICHARD W. JAGOLTA, JR
TINA ZELANO J**

June 3, 2021

The Honorable Kimberley Driscoll
Mayor of Salem
City Hall
Salem, MA 01970

Dear Mayor Driscoll:

I respectfully request a transfer in the amount of \$6,000 from Payroll Account (11411-5111) to Contract Services Account (11412-5308). There are funds available due to the retirement of the former Director of Assessing. Services are being provided on a contract basis for temporary assistance during this transition providing help with appellate tax board cases, issuance of preliminary tax bills and valuation support required at this time.

Thank you for your consideration.

Very truly yours,



Stephen Cortes
Acting Director of Assessing



CITY OF SALEM

In City Council,

Ordered:

June 24, 2021

That the sum of Three Thousand Eight Hundred Twenty-Four Dollars (\$3,824.00) is hereby transferred from the Building Department's "FT Salaries" account (12411-5111) to the Building Department's "Contracted Services" account as provided below to cover remaining payments for short-term rental compliance services for FY2021 in accordance with the recommendation of Her Honor the Mayor.

Description	Fund	Amount
Contracted Services	12412-5320	\$ 3,824.00
		\$ 3,824.00



CITY OF SALEM, MASSACHUSETTS
Kimberley Driscoll
Mayor

June 24, 2021

To the City Council
City Hall
Salem, Massachusetts

Ladies and Gentlemen of the Council:

Enclosed herewith is a request to transfer Three Thousand Eight Hundred Twenty-Four Dollars (\$3,824.00) from the "Building Department's FT Salaries account (12411-5111) to the Building Department's "Contracted Services" account.

Description	Fund	Amount
Contracted Services	12412-5320	\$3,824.00

This transfer is necessary to cover remaining payments for short-term rental compliance services for FY 2021.

Kimberley Driscoll
Mayor



KIMBERLEY DRISCOLL
MAYOR

CITY OF SALEM, MASSACHUSETTS

BUILDING DEPARTMENT
98 WASHINGTON STREET, 2ND FLOOR
TEL: 978-745-9595
FAX: 978-740-9846

THOMAS ST. PIERRE
DIRECTOR OF PUBLIC PROPERTIES/BUILDING COMMISSIONER

June 14, 2021

Mayor Kimberley Driscoll
93 Washington Street
Salem, Ma. 01970

Dear Mayor Driscoll,

I am requesting funds from FY2021 to be used to pay an invoice we received from LTAS Technologies Inc./Harmari from money available in the Building Department's salary line (12411-5111) as we do not have enough funds in Contract Services (12412-5320).

Attached is a copy of the invoice dated May 6, 2021 and the completed transfer fund form.

Thank you for your attention in this matter.

Sincerely,

A handwritten signature in black ink, appearing to read "Thomas St. Pierre".

Thomas St. Pierre
Director of Inspectional Services

CITY OF SALEM – Finance Department

Free Cash, W & S R/E, R/Res & Budget Transfer Request Form

From: Inspectional Services

Department

Department Head Authorizing Signature

June 14, 2021

Date

Budget or R/Res

Budget Amt: _____

Transfers

To : _____
(Org/Object)

Desc: _____

Balance: _____

Budget Amt: _____

From : _____

Desc: _____

Balance: _____

(*Note - Please include letter to Mayor for Transfers from different Personnel & Non-personnel lines)

Current Balance in Receipts Reserved Fund Above (if applicable) - \$ _____

Date: _____

Free Cash or From : 12411-5111

Desc: FT Salary

To: 12412-5320

Budget Amt: \$588,115.70

Balance: \$90,211.81

Retained Earnings (W/S) (Org/Object)

Desc: Contracted Services

Raise & Appropriate

Please circle one

Amount Requested:

\$ \$3,824.00

Reason (Be Specific) Invoice from LTAS Technologies, Inc./Harmari for Short Term Rental Compliance services. Amount currently available from this account will not cover the payment of this invoice. There is, however, sufficient funds from earnings as Sally Murtagh retired from out department at the end of March of this year.

For Finance Department and Mayor's Use Only:

Budget Transfer Mayor Approval City Council Approval

Free Cash Appropriation – City Council Approval – Gen Fund \$ _____
Free Cash Balance

R/E Appropriation –Water \$ _____ R/E Balance R/E Appropriation Sewer \$ _____ R/E Balance

Receipts Reserve – City Council Approval \$ _____
R/Res Fund Balance

Raise & Appropriate Other _____

Recommendation: Approved Denied

Finance Director

Completed: Date: _____ By: _____ CO # _____ JE#: _____ Transfer #: _____



CITY OF SALEM

In City Council,

Ordered:

June 24, 2021

That the sum of Two Thousand Eight Hundred Dollars (\$2,800.00) is hereby transferred from the Purchasing Department's "Office Supplies" account (11382-5421) to the Purchasing Department's Fixed Cost "Copier & Supplies" account as provided below to cover remaining payments for copier leases and usage for FY2021 in accordance with the recommendation of Her Honor the Mayor.

Description	Fund	Amount
Copier & Supplies	11392-5422	\$ 2,800.00
		\$ 2,800.00



CITY OF SALEM, MASSACHUSETTS

Kimberley Driscoll

Mayor

June 24, 2021

To the City Council
City Hall
Salem, Massachusetts

Ladies and Gentlemen of the Council:

Enclosed herewith is a request for a transfer of Two Thousand Eight Hundred Dollars (\$2,800.00) from the Purchasing Departments' "Office Supplies" account (11382-5421) to the Purchasing Department's Fixed Cost "Copier & Supplies" account.

This transfer is necessary to cover remaining payments for copier leases and usage for FY 2021.

I recommend passage of the accompanying Order.

Very truly yours,

A handwritten signature in cursive script, appearing to read "Kimberley Driscoll".

Kimberley Driscoll

Mayor



CITY OF SALEM, MASSACHUSETTS

PURCHASING DEPARTMENT
93 WASHINGTON STREET, 3RD FLOOR
SALEM, MA 01970
TEL. (978) 619-5696
TWATLKINS@SALEM.COM

KIMBERLEY DRISCOLL
MAYOR

THOMAS P. WATKINS
PURCHASING AGENT

June 14, 2021

The Honorable Mayor Kimberly Driscoll
City of Salem
93 Washington Street
Salem, MA 01970

Subject: Copier & Supplies – Office Supplies

Dear Mayor Driscoll:

We respectfully request an appropriation of funds in the amount Two Thousand Eight Hundred Dollars (\$2,800.00) from the following account:

11382-5421 – Office Supplies - \$2,800.00

to be transferred into the Copier & Supplies account – 11392-5422. This appropriation will allow for the past due and end of year payments for copier usage, as well as a few copier lease payments for the remainder of Fiscal Year 2021.

Respectfully yours,

 Anna Freedman
Finance Director
on behalf of
the Purchasing Dept.

City of Salem

In the year two thousand and twenty-one

An Ordinance to amend an Ordinance establishing the Race Equity Commission

Be it ordained by the City Council of the City of Salem, as follows:

Section 9. Chapter 2, Article IV of the Code of Ordinances is hereby amended by adding the following new Division following Division 17:

“Division 18. – RACE EQUITY COMMISSION

- Sec. 2-1032. There is hereby established a race equity commission for the purpose of:
- (a) implementing elements of the City’s Race Equity Action Plan and updating said plan periodically as necessary;
 - (b) advising departments and City officials on strategies and approaches to ensure municipal programs, policies, budgets, and ordinances are developed in a manner that avoid and reduce systemic racism and bias;
 - (c) developing and recommending initiatives, programs, and policies intended to reduce systemic racism and bias in Salem;
 - (d) designing and conducting hiring and recruitment programs and advise on employee training and retention programs to increase diversity and cultural competency of City staff;
 - (e) supporting and guiding community organizations, employers, associations, nonprofits, agencies, businesses, and others in methods by which they can help reduce systemic racism and improve racial equity in Salem; and
 - (f) seeking grants and other sources of support and resources to carry out the Commission’s work.

Sec. 2-1033. The commission shall consist of seven members: the City’s Human Resources Director or their designee, the City Solicitor or their designee, the School Superintendent or their designee and four other members appointed by the Mayor and subject to City Council confirmation. The members shall each serve a term of three years.”

Section 99. This Ordinance shall take effect as provided by City Charter.



CITY OF SALEM, MASSACHUSETTS

Kimberley Driscoll
Mayor

Office of the Mayor

June 24, 2021

Honorable Salem City Council
Salem City Hall
Salem, Massachusetts 01970

Ladies and Gentlemen of the City Council:

As you may recall, one year ago on June 25, 2020, the City announced the formation of a Race Equity Task Force to carry out a thorough review of City policies, services, and ordinances, as well as inequities in community systems and report out clear recommendations, including ways in which success will be measured, in an Equity Action Plan. The Task Force has been meeting regularly since that date, both as a whole and in smaller working groups, and we are pleased to share with you that their report will be issued in the coming days.

On behalf of the Task Force, we are submitting the enclosed Ordinance to transition the Task Force from an informal and temporary body into a permanent Race Equity Commission.

We are incredibly grateful to the members of the Race Equity Task Force, who have dedicated themselves over this past year to the important work of addressing systemic racism and inequities in our community. That work, however, does not come to an end just because the Task Force is reaching the end of their process. The proposed Commission, in combination with the new Director of Diversity, Equity, and Inclusion, are intended to carry on this important work in the years to come, to ensure Salem only strengthens our commitment to being a city that works for and welcomes everyone.

Sincerely,

Kimberley Driscoll
Mayor
City of Salem

Shawn Newton
Chair
Salem Race Equity Task Force

City of Salem

In the year Two Thousand and Twenty-One

An Ordinance to replace gender-specific nouns and pronouns in the City of Salem's Zoning Code of Ordinances.

Be it ordained by the City Council of the City of Salem, as follows:

AN ORDINANCE REPLACING GENDER-SPECIFIC NOUNS AND PRONOUNS IN THE CITY OF SALEM'S ZONING CODE OF ORDINANCES

Be it ordained by the City Council of Salem, as follows:

SECTION I. The City of Salem Zoning Code is hereby amended as follows:

1. In section 1.5 replace "his" with "the registered land surveyor's" in all one instance.
2. In section 4.2.1 replace "his" with "the Head of the Fire Department's" in all two instances.
3. In section 6.2.1 replace "he" with "be" in all one instance.
4. In section 6.11.5(3) replace "craftsmen" with "craftspeople" in all one instance.
5. In section 7.2.1 replace "his" with "their" in all one instance.
6. In section 7.2.3 replace "his" with "the Head of the Fire Department's" in all two instances.
7. In section 7.3.7 replace "his" with "the Head of the Fire Department's" in all two instances.
8. In section 8.1.7 replace "his successor" with "the petitioner's" in all one instance.
9. In section 8.1.7 replace "his designee" with "the Head of the Fire Department's designee" in all two instances.
10. In section 8.1.8(2) replace "Man-made" with "Artificial" in all one instance.
11. In section 8.3.8 replace "his" with "the Head of the Fire Department's" in all two instances.
12. In section 8.4.5(1.1) replace "craftsmen" with "craftspeople" in all one instance.
13. In section 8.4.5(6.1) replace "fraternal" with "social" in all one instance.

14. In section 9.1.3 replace “he” with “be” in all one instance.
15. In section 9.2.1 replace “He” with “The Building Commissioner” in all one instance.
16. In section 9.2.2 replace “he” with “they” in all one instance.
17. In section 9.2.2 replace “He” with “The Building Commissioner” in all one instance.
18. In section 9.5.5 replace “his” with “the Head of the Fire Department's” in all two instances.
19. In section 9.3.1(1) replace “chairman” with “chair” in all one instance.
20. In section 10 replace “fraternity houses” with “collegiate Greek system residences” in all one instance.

SECTION II. This ordinance shall take effect as provided by the City Charter.



CITY OF SALEM, MASSACHUSETTS

Kimberley Driscoll
Mayor

Office of the Mayor

June 24, 2021

Honorable Salem City Council
Salem City Hall
Salem, Massachusetts 01970

Ladies and Gentlemen of the City Council:

Earlier this year the Council adopted an Ordinance to ensure our general Code of Ordinances uses inclusive language that is reflective of all of our residents. As the next part of that ongoing work, we are pleased to submit to you the enclosed measure to also make these corrections to our Zoning Code.

There are 20 instances of gender-exclusive language in our Zoning Code, the set of ordinances which govern and regulate the use of land in our community. We recommend the enclosed Ordinance be scheduled for a joint public hearing with the Planning Board, so that these grammatical changes can be made to the Zoning Code and make certain that it is inclusive and reflective of all of the residents of our City.

We look forward to working with you and the Planning Board members to continue the important work of updating our local laws to ensure that they do not exclude or minimize anyone in Salem.

Sincerely,

Kimberley Driscoll
Mayor
City of Salem

Councillor Patricia Morsillo
Chair
Ordinances, Licenses, and Legal Affairs Committee



CITY OF SALEM, MASSACHUSETTS

Kimberley Driscoll
Mayor

Office of the Mayor

June 24, 2021

Honorable Salem City Council
Salem City Hall
Salem, Massachusetts 01970

Ladies and Gentlemen of the City Council:

This letter is to provide you and Salem residents with an update on the implementation of the American Rescue Plan Act (ARPA) here in our community. As you are aware, ARPA was a far-reaching federal COVID relief measure that included, as one component, an allocation of federal aid to cities and towns to help them recover from the pandemic and rebuild our communities.

Salem is expected to receive approximately \$26.6 million in direct aid and an additional approximately \$8.3 million through the state. In addition to these funds, Salem Public Schools will receive a direct allocation of approximately \$9 million. Salem's direct municipal aid is being allocated in two payments, the first of which, for \$13.3 million, we received on June 14, 2021.

A few weeks prior, the U.S. Treasury Department issued their "Interim Final Rule" establishing the guardrails and guideposts for the use of this historic relief funding. You can read the Rule at <https://public-inspection.federalregister.gov/2021-10283.pdf> and find a summary at <https://home.treasury.gov/system/files/136/SLFRP-Fact-Sheet-FINAL1-508A.pdf>.

Locally, we plan to retain a dedicated professional – funded entirely by ARPA dollars – to work in-house and help us manage this initiative, reconcile and report to Treasury as required by the law, and ensure these dollars are used transparently and effectively to help our community recover from COVID.

Our plan is to approach ARPA in a manner reflective of our community's values and priorities. Over the coming weeks we will launch a public survey and assemble a working group of residents, officials, and community leaders to develop a document outlining the principles by which we will evaluate and select funding opportunities to best leverage this allotment of federal dollars. We intend to be thoughtful in our use of this one-time funding, working to support re-

investment in our community, while addressing short and long term goals of our existing capital and operational plans. All of this must be done within the confines of the federal government's limitations on eligible uses of ARPA dollars.

This is a significant investment in our community, and we are grateful to the President, his staff, and the members of Congress who supported and made this historic legislation possible. Congressman Moulton, Senator Markey, and Senator Warren each advocated in support of this important legislation, which will help stabilize and grow our local economy post-pandemic. Clearly, there are immediate needs to be addressed, as well as a desire to use these funds to leverage future, equitable prosperity for our City. We will also evaluate opportunities to work with other communities in our region and with state agencies in a complimentary manner, to further maximize the impact of these resources.

Salem residents rightly expect that we will be transparent and thoughtful with respect to this federal funding. There are no shortage of needs and this aid will provide an opportunity to plan and leverage resources for the benefit of everyone in our community. To meet our constituents right to transparency in this effort, we will report publicly both to the Council and online at www.salem.com/rescue in regard to our plans for ARPA-funded projects and programs.

Salem residents should be confident and comfortable in our ability to manage this process appropriately. We have, for the last 12 years in a row, received the Government Finance Officers Association's Distinguished Budget Presentation Award and their Certificate of Achievement for Excellence in Financial Reporting. Our financial statements are audited annually, and our budget practices have been based on professionalism, transparency, and fiscal responsibility. These practices have resulted in the rebuilding of our local reserve funds from when I first came into office in 2006, the upgrading of our bond rating to its strongest level in the City's history, and the highest levy capacity also in our City's history. Moreover, we have experience with managing sizable federal grant awards in a responsible manner as we currently receive and manage approximately \$12 million in federal funding awards annually.

We look forward to working collectively to expend these dollars in a way that is transparent, strategic, equitable, and sensible.

Sincerely,



Kimberley Driscoll
Mayor
City of Salem



CITY OF SALEM

In City Council,

June 24, 2021

Ordered:

That the City Council determine how to conduct their City Council Meetings and sub-committee meetings effective June 25, 2021, until April 1, 2022

City of Salem



Tag Day

Date 6/1/2021

Police Dept. Approval	<input checked="" type="checkbox"/>
Date(s) Recorded	<input checked="" type="checkbox"/>
Copy of Tag Received	<input checked="" type="checkbox"/>

TO THE CITY COUNCIL:

We, the undersigned, respectfully apply for a TAG DAY license as follows:

Name of Organization: Salem Little League / Jimmy Fund *
 Address of Organization: PO Box 623 Salem, MA 01970
 Date(s) Requested to Tag: Saturday, July 10, 2021
 Time: 8-2

OFFICERS OF THE ORGANIZATION (2 SIGNATURES REQUIRED):

Sarah Sosnowski Sarah Sosnowski 12 Barton St 978-594-4258
 (Please Print Name) (Signature) (Address) (Tel. No.)

Ed Colbert Ed Colbert III 70 Valley St. Salem 978-430-7795
 (Please Print Name) (Signature) (Address) (Tel. No.)

A sample of the Tag must be given to the City Clerk before any license can be released Ch. 14, Sec. 105.

No person authorized shall make or attempt to make any sale in front of private premises against the objection of the owner or occupant thereof per City Ordinance Ch. 14, Sec. 103.

[Signature]
 Police Department Approval

THIS LICENSE SHALL NOT BE VALID UNLESS BOTTOM PORTION IS COMPLETED WITH SIGNATURE OF THE CITY CLERK

In City Council JUN 24 2021
 Referred to the Committee on Ordinances, Licenses & Legal Affairs

In City Council _____
 LICENSE GRANTED contingent upon above organization distributing "Tags" as defined by Chapter 14, Sec. 102 of the Salem Code of Ordinance

ATTEST:

Ilene Simons

ILENE SIMONS, CITY CLERK



June 2, 2021

To whom it may concern,

On behalf of the Salem Little League Volunteer Board of Directors, I thank you for considering this application.

To clear up any initial confusion, yes, Salem Little League has been approved and scheduled our allotted tag days to benefit our non-profit league and the kids of Salem, with our final date benefiting the league and its players being on June 19.

What makes this request unique is that while it will be Salem Little League players and volunteers doing the canning/tagging, 100% of the proceeds from this additional date will go directly to the Jimmy Fund.

Jimmy Fund Little League provides more than 5,000 Little League baseball and softball players throughout New England the chance to continue playing after their regular season ends, while fundraising for Dana-Farber Cancer Institute. These players raise vital funds for the Jimmy Fund while learning the importance of philanthropy and volunteerism, and that they, too, can make a difference in the fight against cancer.

Since 1987, the hard work and winning spirit of the coaches, parents and, most importantly, the players, have raised more than \$5 million for the Jimmy Fund. For more information on this program, please visit <https://www.jimmyfund.org/events/cancer-fundraising-events/jimmy-fund-little-league/>

Salem Little League has not participated in **Jimmy Fund Little League** in quite some time, for reasons I am not fully aware of, nor understand.

As the acting League President, I would like Salem Little League to participate this year, assuming there are enough volunteer coaches and players interested in playing summer baseball. This will get the kids involved as philanthropists and give the kids some organized activities this summer, after a long and hard 15 months.

The **Jimmy Fund Little League** summer season does consist of a championship between the top two teams in each age group- but it is not based on your win loss record. You can be 10-0, and not be in the championship. You can be 0-10, never winning a game, and be in the championship. The sole factor in determining who makes it to the championship game is how much money each team raised for the Jimmy Fund.

Players will be expected to do their own fundraising as well, but I thought obtaining a tag date, with all proceeds benefiting the Jimmy Fund, would assist them in their efforts. They would still have to man their locations.

We thank you in advance for your consideration. Feel free to contact me if you have any questions or concerns.

Best,

Ed Colbert

League President

Salem Little League

cell. 978-430-7795

address. PO Box 623, Salem, MA 01970

website: WWW.SALEMLL.INFO

Thank you for supporting



Salem Little League
<https://www.jimmyfund.org/events/cancer-fundraising-events/jimmy-fund-little-league/>

Together we can Strike Out Cancer!!!
100% of donations today go to the Jimmy Fund

Thank you for supporting



Salem Little League
<https://www.jimmyfund.org/events/cancer-fundraising-events/jimmy-fund-little-league/>

Together we can Strike Out Cancer!!!
100% of donations today go to the Jimmy Fund

Thank you for supporting



Salem Little League
<https://www.jimmyfund.org/events/cancer-fundraising-events/jimmy-fund-little-league/>

Together we can Strike Out Cancer!!!
100% of donations today go to the Jimmy Fund

Thank you for supporting



Salem Little League
<https://www.jimmyfund.org/events/cancer-fundraising-events/jimmy-fund-little-league/>

Together we can Strike Out Cancer!!!
100% of donations today go to the Jimmy Fund

Thank you for supporting



Salem Little League
<https://www.jimmyfund.org/events/cancer-fundraising-events/jimmy-fund-little-league/>

Together we can Strike Out Cancer!!!
100% of donations today go to the Jimmy Fund

Thank you for supporting



Salem Little League
<https://www.jimmyfund.org/events/cancer-fundraising-events/jimmy-fund-little-league/>

Together we can Strike Out Cancer!!!
100% of donations today go to the Jimmy Fund



CITY OF SALEM

In City Council,

June 24, 2021

Ordered:

That the Committee on Administration and Finance co-posted with the Committee of the Whole meet to review the state of CARES and ARPA funding, the city's application for assistance under those acts, and eligible services, stabilization efforts, and infrastructure spending under them and the following be invited: Mayor, Finance Director and others relevant to discussion



City of Salem

FY 2021 MONTHLY FINANCIAL REPORTS

April 2021

REPORTS

FUND BALANCES

REVENUE STATEMENT	STABILIZATION	\$ 7,832,043.41
CIP, SALE OF CITY PROPERTY & RETIREMENT STABILIZATION	CAPITAL OUTLAY	\$ 116,653.90
FREE CASH, ENTERPRISE RE	SALE OF CITY PROP	\$ 11,791.50
DEPARTMENTAL BUDGET REPORTS	RETIREMENT STAB	\$ 153,331.53
BUDGET TRANSFER DETAIL -	OPFB	\$ 3,483,673.13
	**FREE CASH	\$ -
	**WATER & SEWER R/E	\$ -
	**TRASH R/E	\$ -

** FY2020 FC & Retained earnings are to be certified by DOR

CITY OF SALEM
April 30, 2021
REVENUE STATEMENT

GENERAL FUND	RECAP FY 2021	ACTUAL MONTH TO DATE	ACTUAL YEAR TO DATE	Y-T-D % COLLECTED	VARIANCE Y-T-D +/-
REAL AND PERSONAL(NET)	107,301,006	22,881,870	103,809,419	96.75%	(3,491,587)

MOTOR VEHICLE	4,100,000	239,604	3,825,742	93.31%	(274,258)
HOTEL EXCISE	350,000	74,518	393,606	112.46%	43,606
MEALS TAX	400,000	188,922	683,530	170.88%	283,530
OTHER	500,000	-	-	0.00%	(500,000)
VESSEL EXCISE*	30,000	1,357	61,404	204.68%	31,404
CANNABIS CBA	500,000	-	973,523	194.70%	473,523
CANNABIS EXCISE	400,000	282,047	803,143	200.79%	403,143
INTEREST ON TAXES	400,000	106,188	494,293	123.57%	94,293
PAYMENT IN LIEU OF TAXES (PILOT	700,000	105,203	751,556	107.37%	51,556
CHARGES FOR SERVICES	1,600,000	579,049	2,500,405	156.28%	900,405
PARKING FEES	1,500,000	148,623	2,037,511	135.83%	537,511
LICENSES AND PERMITS	172,500	217,758	493,272	285.95%	320,772
FINES AND FORFEITS	600,000	124,491	881,465	146.91%	281,465
INVESTMENT INCOME	171,750	10,279	144,442	84.10%	(27,308)
MISCELLANEOUS INCOME	230,000	2,093	858,045	373.06%	628,045
MEDICAID INCOME SCHOOL SPED	450,000	-	238,510	53.00%	(211,490)
NON RECURRING	0	0	186,836	#DIV/0!	186,836
TOTAL LOCAL RECEIPTS	12,104,250	2,080,130	15,327,284	126.63%	3,223,034

NET MA CHERRY SHEET ASST.	34,120,336	5,714,551	28,497,349	83.52%	(5,622,987)
MSBA REIMBURSEMENTS	0	-	-	#DIV/0!	0
R/RES REDUCE TAX RATE	975,000	-	975,000	100.00%	0
OFS/TRANSFERS IN	0	-	199,990	#DIV/0!	199,990
INDIRECT COSTS from W&S	1,494,176	-	1,494,176	100.00%	0
TOTAL OTHER RECEIPTS	36,589,512	5,714,551	31,166,515	85.18%	(5,422,997)
GENERAL FUND TOTAL	155,994,768	30,676,551	150,303,217	96.35%	(5,691,551)

ENTERPRISE FUND

SEWER RATES	10,165,959	859,739	8,861,720	87.17%	(1,304,239)
SEWER TRANS/OFS	-	-	-	#DIV/0!	0
WATER RATES	5,795,306	493,120	5,022,838	86.67%	(772,468)
WATER TRANS/OFS	-	-	-	-	0
Total Water & Sewer	15,961,265	1,352,859	13,884,558	86.99%	(2,076,707)

TRASH FEES	899,925	78,815	803,450	89.28%	(96,475)
TRASH General Fund Subsidy/OFS	2,976,274	-	2,976,274	100.00%	0
Total Trash	3,876,199	78,815	3,779,724	97.51%	(96,475)

PEG ACCESS	691,250	0	489,074	70.75%	(202,176)
Total Peg Access	691,250	0	489,074	70.75%	(202,176)
ENTERPRISE FUND TOTAL	20,528,714	1,431,674	18,153,357	88.43%	(2,375,357)
GRAND TOTAL	176,523,482	32,108,225	168,456,574	95.43%	(8,066,908)

*50% of Vessel Excise is transferred to Harbormaster R/Res Fund on 6/30 PER MGL CH60B

**CITY OF SALEM, MASSACHUSETTS
FY 2021 Short Term Capital Improvement Program Activity - Fund 2000**

Department	Description	Org/Obj	Date	Pending Amount	Approved Amount	CO #	Approved Amount	Repurposed and/or TF In	Y-T-D Paid	Outstanding Balance
------------	-------------	---------	------	----------------	-----------------	------	-----------------	-------------------------	------------	---------------------

Prior to FY2020 - Open Projects 192,225.73

FY 2020 - Open Projects										
FY 2020 Beginning Balance 2,836,664.03										
City Clerk	Vault Storage	20002003-5846BA	5/23/2019		06/25/19		(51,125.00)		51,125.00	-
Fire	SCBA Equipment	20002010-5846BB	5/23/2019		06/25/19		(24,940.00)		16,363.64	8,576.36
Fire	Bldg Maint/Upgrades	20002010-5846BC	5/23/2019		06/25/19		(30,000.00)		21,012.28	8,987.72
Park & Rec	Golf Course Equip	20002017-5846BD	5/23/2019		06/25/19		(55,723.00)		55,600.62	122.38
Park & Rec	SHS Tennis Courts	20002017-5846BE	9/12/2019		9/12/2019	511	(200,000.00)		199,999.96	0.04
Planning	Gallows Hill Pk Renov Proj	20002020-5846BF	9/12/2019		9/12/2019	510	(350,000.00)		218,398.48	131,601.52
Park & Rec	Naumkeag/Pioneer Study	20002017-5846BG	12/5/2019		12/5/2019	715	(100,000.00)		71,225.25	28,774.75
Police	Elevator Repair	20002021-5846BH	2/13/2020		2/13/2020	62	(6,746.00)		6,746.00	-
Fire	Heating System Replacement/Repair	20002010-5846BI	2/13/2020		2/13/2020	62	(23,145.00)		23,145.00	-
Fire	Antenna	20002010-5846BJ	2/13/2020		2/13/2020	62	(24,250.00)	(30,000.00)	31,928.78	22,321.22
Planning	Highland Ave Study	20002020-5846BK	2/13/2020		2/27/2020	59	(40,000.00)	40,000.00	-	-
Electric	Leslie Retreat Park	20002008-5846BL	2/27/2020		2/27/2020	137	(15,680.59)		-	15,680.59
DPS	Salt Shed Study	20002023-5846BM	3/12/2020		3/12/2020	165	(30,000.00)		27,243.46	2,756.54
DPS	Roof Repair	20002023-5846BN	3/12/2020		3/12/2020	163	(175,000.00)		173,621.86	1,378.14
Health	Mack Park Farm	20002012-5846BO	4/9/2020		4/9/2020	208	(20,000.00)		19,800.00	200.00
Veterans	Riley Plaze Flag Pole Repair	20002028-5846BP	4/23/2020		4/23/2020	241	(2,840.08)		-	2,840.08
Engineering	McGrath Park Soils Investigation	20002029-5846BQ	4/23/2020		4/23/2020	239	(20,000.00)		7,284.57	12,715.43
Planning	Beverly-Salem Climate Action Plan	20002020-5846BR	5/28/2020		5/28/2020	274	(32,000.00)		32,000.00	-
Park & Rec	Bertram Field	20002017-5846BS	6/25/2020		6/25/2020	322	(391,140.00)		150,360.00	240,780.00
Park & Rec	Pioneer Village/Camp Naumkeag relectric	20002017-5846BG	7/9/2020		9/10/2020	349	(130,000.00)		-	130,000.00
Planning	Common Fence Restoration	20002020-5846BU	7/9/2020		9/10/2020	359	(80,000.00)		-	80,000.00

FY 2021 - Open Projects **FY 2021 Beginning Balance 1,034,094.36**

Library	Main Elevator Repair	20002114-5846CA	11/19/2020		11/19/20	483	(7,458.00)		7,458.00	-
Library	Fire Alarm System	20002114-5846CB	1/28/2021		01/28/21	34	(4,950.00)		4,950.00	-
Engineering	Essex Street Roadway and Sidewalk	20002129-5846CC	2/25/2021		02/25/21	65	(200,000.00)		596.40	199,403.60
School	Bentley Academy Innovation	20002125-5846CD	3/11/2021		03/11/21	112	(124,121.00)		36,138.43	87,982.57
City Council	Furnishing Repairs and Restoration	20002103-5846CE	3/25/2021		03/25/21	143	(18,795.00)		13,747.50	5,047.50
Traffic & Parkin	Garage Equipment Upgrade	20002118-5846CF	3/25/2021		03/25/21	139	(175,000.00)		175,000.00	-
Traffic & Parkin	Bike Share program equipment	20002118-5846CG	3/25/2021		04/22/21	140	(50,000.00)		50,000.00	-
P&R	WH Furniture & Fixtures	20002117-5846CH	3/25/2021		03/25/21	142	(4,000.00)		4,000.00	-
Engineering	WS Emergency	20002129-5846CI	4/22/2021		04/22/21	198	(37,441.46)		37,441.46	-
Traffic & Parkin	Garage Public Restrooms	20002118-5846CJ	4/22/2021		04/22/21	197	(250,000.00)		250,000.00	-
DPS/Engineer	DPS Facility Fuel Canopy	20002129-5846CK	4/22/2021		04/22/21	203	(15,675.00)		15,675.00	-
Planning	Artist Row Bathroom Upgrade	20002120-5846CL	4/22/2021		04/22/21	200	(30,000.00)		30,000.00	-

FY 2021 Pending Total	-	2021 YTD Balance	116,653.90	Total Open Balances	1,735,439.26
		<i>Pending Balance --></i>	116,653.90	Total Munis Fund Bal	1,852,093.16

**City of Salem, Massachusetts
FY 2021 Sale Of Property Fund - Fund 2441**

Department	Description	Org/Obj	Date To Council	Pending Amount	Date Approved	CO #	Approved Amount	Y-T-D Paid	Amt Not Used	Date Paid	Outstanding Balance
				FY 2021 Beginning Balance			1,790.50				
							Revenue Collected To Date				
							10,001.00				
				FY 2021 Pending CO Total			-				
							FY 2021 YTD Balance				
							11,791.50				
								Total Open Balances -->			34,026.86
								Total Fund Bal -->			45,818.36

City of Salem, Massachusetts FY 2021 Retirement Stabilization - Fund 8311

Department	Description	Org/Obj	Date To Council	Pending Amount	Date Approved	CO #	Approved Amount	Y-T-D Paid	Amt (Over)/Under Paid	Date Paid
------------	-------------	---------	-----------------	----------------	---------------	------	-----------------	------------	-----------------------	-----------

FY 2021 Beginning Balance **452,314.18**

Transfers In 700,000.00

DPW	Stephen Tassinari	83113-5146	09/10/20		09/10/20	390	(29,213.42)	29,213.42	-	10/01/20
Fire	John Monahan	83113-5146	09/10/20		09/10/20	389	(46,486.20)	46,486.20	-	10/01/20
IT	Biane Boyajian	83113-5146	09/10/20		09/10/20	389	(4,541.55)	4,541.55	-	10/01/20
IT	Bosco Kwok	83113-5146	09/10/20		09/10/20	389	(3,183.69)	3,183.69	-	10/01/20
Police	Kathleen Makros	83113-5146	09/10/20		09/10/20	389	(55,895.84)	55,895.84	-	10/01/20
Police	Chief Mary Butler	83113-5146	09/10/20		09/10/20	389	(60,808.32)	60,808.32	-	10/01/20
Police	Dana Mazola	83113-5146	09/10/20		09/10/20	389	(23,090.40)	23,090.40	-	10/01/20
School	Donna Brady	83113-5146	09/10/20		09/10/20	389	(25,387.44)	25,387.44	-	10/01/20
School	Geoffrey Raymond	83113-5146	09/10/20		09/10/20	389	(35,880.80)	15,697.85	20,182.95	10/01/20
School	Alicia Sheridan	83113-5146	09/10/20		09/10/20	389	(18,215.20)	18,215.20	-	09/24/20
School	Virginia LeBlanc	83113-5146	09/10/20		09/10/20	389	(16,768.40)	16,768.40	-	10/01/20
Fire	Richard Armo	83113-5146	10/08/20		10/08/20	445	(54,694.44)	54,694.44	-	10/22/20
School	Donna Sullivan	83113-5146	11/19/20		11/19/20	484	(2,662.20)	2,662.20	-	12/17/20
School	David Kezar	83113-5146	11/19/20		11/19/20	481	(21,639.80)	21,639.80	-	12/17/20
School	John Robinson	83113-5146	11/19/20		11/19/20	482	(20,354.40)	20,354.40	-	12/17/20
Police	Andrew Dacy	83113-5146	12/03/20		12/03/20	527	(49,250.88)	49,250.88	-	12/17/20
Police	Harry Rochville	83113-5146	12/03/20		12/03/20	526	(58,980.44)	59,080.44	-	12/17/20
School	Susan Redfield	83113-5146	01/14/21		01/14/21	11	(16,768.00)	16,768.00	-	02/04/21
School	Jane Harrington	83113-5146	01/14/21		01/14/21	9	(34,058.58)	34,058.58	-	02/04/21
Parking Garage	Robert O'Keefe	83113-5146	01/28/21		01/28/21	35	(4,145.08)	4,145.08	-	02/18/21
Fire	William Luzinski	83113-5146	02/11/21		02/11/21	60	(46,301.62)	46,301.62	-	03/04/21
Fire	Robert Cook	83113-5146	02/11/21		02/11/21	59	(49,634.40)	49,634.40	-	03/04/21
Fire	John Morrison	83113-5146	02/11/21		02/11/21	61	(46,301.62)	46,301.62	-	03/04/21
Fire	Frank DeFranco	83113-5146	02/11/21		02/11/21	62	(9,316.80)	9,316.80	-	03/04/21
Planning	Kathleen Wfnn	83113-5146	03/11/21		03/11/21	114	(4,095.59)	4,095.59	-	03/25/21
HR	Union 2 day buyback	83113-5146	03/11/21		03/11/21	113	(53,396.00)	91,144.90	-	04/15/21
Fire	John Guinla	83113-5146	03/25/21		03/25/21	136	(91,144.90)	62,599.80	-	04/15/21
Fire	Kevin Koan	83113-5146	03/25/21		03/25/21	136	(62,599.80)	62,943.56	-	04/15/21
Fire	Michael Leonard	83113-5146	03/25/21		03/25/21	136	(62,943.56)	12,199.39	-	05/08/21
Building	Sally Murtagh	83113-5146	04/22/21		04/22/21	204	(6,119.76)	6,119.76	-	06/10/21
Assessing	Deborah Jackson	83113-5146	05/27/21		05/27/21	268	(12,524.14)	12,524.14	-	06/10/21
Clerk's Office	Linda Serpa	83113-5146	05/27/21		05/27/21	268	(12,524.14)		-	

Interest earned 793.16

Add Back Amounts not Used 20,182.95

Pending	-	FY 2021 YTD Balance	<u>134,687.63</u>
Balance Less Pending		Total Fund Bal	<u>20,182.95</u>
			<u>134,687.63</u>



FOR 2021 10

	ORIGINAL APPROP	TRANS/ADJSMTS	REVISED BUDGET	YTD EXPENDED	ENCUMBRANCES	AVAILABLE BUDGET	% USED
010 ASSESSORS							
1 Personnel	316,033.87	2,357.67	318,391.54	256,156.16	0.00	62,235.38	80.5%
2 Expenses	55,400.00	0.00	55,400.00	53,080.57	1,170.34	1,149.09	97.9%
TOTAL ASSESSORS	371,433.87	2,357.67	373,791.54	309,236.73	1,170.34	63,384.47	83.0%
030 CITY CLERK							
1 Personnel	591,143.03	9,986.53	601,129.56	503,914.72	0.00	97,214.84	83.8%
2 Expenses	145,615.00	1,885.90	147,500.90	108,300.27	29,371.65	9,828.98	93.3%
TOTAL CITY CLERK	736,758.03	11,872.43	748,630.46	612,214.99	29,371.65	107,043.82	85.7%
040 COLLECTOR							
1 Personnel	238,335.06	298.54	238,633.60	198,148.64	0.00	40,484.96	83.0%
2 Expenses	7,600.00	281.17	7,881.17	6,162.76	1,066.41	652.00	91.7%
TOTAL COLLECTOR	245,935.06	579.71	246,514.77	204,311.40	1,066.41	41,136.96	83.3%
060 COUNCIL ON AGING							
1 Personnel	476,050.43	3,189.71	479,240.14	330,251.40	0.00	148,988.74	68.9%
2 Expenses	82,450.00	7,828.91	90,278.91	26,935.48	32,883.90	30,459.53	66.3%

FOR 2021 10

	ORIGINAL APPROP	TRANS/ADJSMTS	REVISED BUDGET	YTD EXPENDED	ENCUMBRANCES	AVAILABLE BUDGET	% USED
TOTAL COUNCIL ON AGING	558,500.43	11,018.62	569,519.05	357,186.88	32,883.90	179,448.27	68.5%
070 INFORMATION TECHNOLOGY-GIS							
1 Personnel	736,710.05	5,791.04	742,501.09	563,744.64	0.00	178,756.45	75.9%
2 Expenses	781,558.00	17,953.47	799,511.47	569,321.49	149,827.90	80,362.08	89.9%
TOTAL INFORMATION TECHNOLOGY-GIS	1,518,268.05	23,744.51	1,542,012.56	1,133,066.13	149,827.90	259,118.53	83.2%
080 ELECTRICAL							
1 Personnel	380,187.37	3,352.40	383,539.77	302,671.14	0.00	80,868.63	78.9%
2 Expenses	412,940.00	1,218.94	414,158.94	278,685.93	13,407.45	122,065.56	70.5%
TOTAL ELECTRICAL	793,127.37	4,571.34	797,698.71	581,357.07	13,407.45	202,934.19	74.6%
090 FINANCE/AUDITING							
1 Personnel	340,815.88	2,556.66	343,372.54	285,366.19	0.00	58,006.35	83.1%
2 Expenses	52,145.00	928.16	53,073.16	4,976.10	1,193.54	46,903.52	11.6%
TOTAL FINANCE/AUDITING	392,960.88	3,484.82	396,445.70	290,342.29	1,193.54	104,909.87	73.5%
100 FIRE							
1 Personnel	8,992,847.35	133,341.78	9,126,189.13	7,231,210.37	0.00	1,894,978.76	79.2%

FOR 2021 10

	ORIGINAL APPROP	TRANS/ADJSMTS	REVISED BUDGET	YTD EXPENDED	ENCUMBRANCES	AVAILABLE BUDGET	% USED
2 Expenses	497,017.00	0.00	497,017.00	322,261.02	104,800.79	69,955.19	85.9%
TOTAL FIRE	9,489,864.35	133,341.78	9,623,206.13	7,553,471.39	104,800.79	1,964,933.95	79.6%
110 HARBORMASTER							
1 Personnel	326,928.51	1,784.11	328,712.62	257,641.21	0.00	71,071.41	78.4%
2 Expenses	44,100.00	0.00	44,100.00	23,491.36	6,859.89	13,748.75	68.8%
TOTAL HARBORMASTER	371,028.51	1,784.11	372,812.62	281,132.57	6,859.89	84,820.16	77.2%
120 HEALTH DEPT							
1 Personnel	495,563.14	4,111.31	499,674.45	395,663.55	0.00	104,010.90	79.2%
2 Expenses	58,029.00	20,299.45	78,328.45	31,058.71	7,539.72	39,730.02	49.3%
TOTAL HEALTH DEPT	553,592.14	24,410.76	578,002.90	426,722.26	7,539.72	143,740.92	75.1%
130 HUMAN RESOURCES							
1 Personnel	16,466,964.03	153,676.69	16,620,640.72	13,263,458.74	13,222.15	3,343,959.83	79.9%
2 Expenses	13,750.00	19,275.31	33,025.31	18,490.42	3,134.32	11,400.57	65.5%
TOTAL HUMAN RESOURCES	16,480,714.03	172,952.00	16,653,666.03	13,281,949.16	16,356.47	3,355,360.40	79.9%
140 LIBRARY							

FOR 2021 10

140 LIBRARY	ORIGINAL APPROP	TRANS/ADJSTMS	REVISED BUDGET	YTD EXPENDED	ENCUMBRANCES	AVAILABLE BUDGET	% USED
1 Personnel	1,058,785.82	22,761.47	1,081,547.29	765,394.67	0.00	316,152.62	70.8%
2 Expenses	289,282.00	5,000.00	294,282.00	246,411.94	38,484.13	9,385.93	96.8%
TOTAL LIBRARY	1,348,067.82	27,761.47	1,375,829.29	1,011,806.61	38,484.13	325,538.55	76.3%
<hr/>							
160 MAYOR							
1 Personnel	420,500.57	3,286.83	423,787.40	343,665.46	0.00	80,121.94	81.1%
2 Expenses	146,550.00	48,272.26	194,822.26	138,035.38	48,894.34	7,892.54	95.9%
TOTAL MAYOR	567,050.57	51,559.09	618,609.66	481,700.84	48,894.34	88,014.48	85.8%
<hr/>							
170 RECREATION							
1 Personnel	1,022,972.53	27,545.40	1,050,517.93	744,682.88	0.00	305,835.05	70.9%
2 Expenses	623,743.00	43,353.27	667,096.27	354,898.73	161,969.95	150,227.59	77.5%
TOTAL RECREATION	1,646,715.53	70,898.67	1,717,614.20	1,099,581.61	161,969.95	456,062.64	73.4%
<hr/>							
180 TRAFFIC & PARKING DEPT							
1 Personnel	852,853.11	22,330.55	875,183.66	690,309.40	0.00	184,874.26	78.9%
2 Expenses	350,795.00	96,173.77	446,968.77	335,655.77	89,012.19	22,300.81	95.0%
TOTAL TRAFFIC & PARKING DEPT	1,203,648.11	118,504.32	1,322,152.43	1,025,965.17	89,012.19	207,175.07	84.3%
<hr/>							
200 PLANNING							

FOR 2021 10

200 PLANNING	ORIGINAL APPROP	TRANS/ADJSMTS	REVISED BUDGET	YTD EXPENDED	ENCUMBRANCES	AVAILABLE BUDGET	% USED
1 Personnel	618,150.62	23,436.69	641,587.31	504,771.93	0.00	136,815.38	78.7%
2 Expenses	366,263.00	56,324.82	422,587.82	290,729.25	83,147.06	48,711.51	88.5%
TOTAL PLANNING	984,413.62	79,761.51	1,064,175.13	795,501.18	83,147.06	185,526.89	82.6%
210 POLICE							
1 Personnel	10,012,200.82	5,433.85	10,017,634.67	7,647,581.76	0.00	2,370,052.91	76.3%
2 Expenses	693,202.00	31,098.35	724,300.35	597,128.89	95,286.77	31,884.69	95.6%
TOTAL POLICE	10,705,402.82	36,532.20	10,741,935.02	8,244,710.65	95,286.77	2,401,937.60	77.6%
220 PUBLIC PROPERTY							
1 Personnel	630,166.34	5,198.51	635,364.85	478,153.75	0.00	157,211.10	75.3%
2 Expenses	739,200.00	33,488.54	772,688.54	606,786.26	130,203.21	35,699.07	95.4%
TOTAL PUBLIC PROPERTY	1,369,366.34	38,687.05	1,408,053.39	1,084,940.01	130,203.21	192,910.17	86.3%
230 PUBLIC SERVICES							
1 Personnel	1,842,775.51	95,816.81	1,938,592.32	1,381,222.60	0.00	557,369.72	71.2%
2 Expenses	1,715,631.00	185,892.25	1,901,523.25	2,137,349.63	879,285.39	-1,115,111.77	158.6%
TOTAL PUBLIC SERVICES	3,558,406.51	281,709.06	3,840,115.57	3,518,572.23	879,285.39	-557,742.05	114.5%
235 ENGINEERING							

FOR 2021 10

235 ENGINEERING	ORIGINAL APPROP	TRANS/ADJSMTS	REVISED BUDGET	YTD EXPENDED	ENCUMBRANCES	AVAILABLE BUDGET	% USED
1 Personnel	172,151.85	1,336.23	173,488.08	158,517.26	0.00	14,970.82	91.4%
2 Expenses	16,800.00	1.77	16,801.77	3,448.83	1,297.22	12,055.72	28.2%
TOTAL ENGINEERING	188,951.85	1,338.00	190,289.85	161,966.09	1,297.22	27,026.54	85.8%
<hr/>							
240 PURCHASING							
1 Personnel	155,110.61	1,132.76	156,243.37	120,224.02	0.00	36,019.35	76.9%
2 Expenses	95,701.00	178.53	95,879.53	68,717.08	22,892.77	4,269.68	95.5%
TOTAL PURCHASING	250,811.61	1,311.29	252,122.90	188,941.10	22,892.77	40,289.03	84.0%
<hr/>							
250 SCHOOL							
1 Personnel	49,779,685.77	825,557.00	50,605,242.77	34,617,645.85	0.00	15,987,596.92	68.4%
2 Expenses	13,669,963.28	192,457.90	13,862,421.18	8,853,207.00	2,664,236.18	2,344,978.00	83.1%
TOTAL SCHOOL	63,449,649.05	1,018,014.90	64,467,663.95	43,470,852.85	2,664,236.18	18,332,574.92	71.6%
<hr/>							
260 SOLICITOR-LICENSING							
1 Personnel	303,922.10	2,289.46	306,211.56	249,127.36	0.00	57,084.20	81.4%
2 Expenses	78,600.00	0.00	78,600.00	28,286.84	8,447.32	41,865.84	46.7%
TOTAL SOLICITOR-LICENSING	382,522.10	2,289.46	384,811.56	277,414.20	8,447.32	98,950.04	74.3%
<hr/>							
270 TREASURER							

FOR 2021 10

270 TREASURER ORIGINAL APPROP TRANS/ADJSMTS REVISED BUDGET YTD EXPENDED ENCUMBRANCES AVAILABLE BUDGET % USED

1 Personnel	14,305,994.39	13,778.57	14,319,772.96	14,011,190.13	0.00	308,582.83	97.8%
2 Expenses	19,532,465.00	-139,800.18	19,392,664.82	16,620,761.85	6,796.08	2,765,106.89	85.7%
TOTAL TREASURER	33,838,459.39	-126,021.61	33,712,437.78	30,631,951.98	6,796.08	3,073,689.72	90.9%

280 VETERANS SERVICES

1 Personnel	117,287.61	919.58	118,207.19	96,269.73	0.00	21,937.46	81.4%
2 Expenses	411,550.00	0.00	411,550.00	268,052.77	332.08	143,165.15	65.2%
TOTAL VETERANS SERVICES	528,837.61	919.58	529,757.19	364,322.50	332.08	165,102.61	68.8%

900 BUDGET TRANSFERS OUT OF GF

2 Expenses	625,000.00	0.00	625,000.00	0.00	0.00	625,000.00	.0%
TOTAL BUDGET TRANSFERS OUT OF GF	625,000.00	0.00	625,000.00	0.00	0.00	625,000.00	.0%

GRAND TOTAL
152,159,485.65 1,993,382.74 154,152,868.39 117,389,217.89 4,594,762.75 32,168,887.75 79.1%

** END OF REPORT - Generated by Anna Freedman **



FOR 2021 10

	ORIGINAL APPROP	TRANS/ADJSMTS	REVISED BUDGET	YTD EXPENDED	ENCUMBRANCES	AVAILABLE BUDGET	% USED
6000 Sewer Enterprise Fund							
230 PUBLIC SERVICES							
1 Personnel	466,797.92	3,450.12	470,248.04	305,821.22	0.00	164,426.82	65.0%
2 Expenses	180,000.00	22,245.06	202,245.06	107,996.18	79,855.09	15,393.79	92.4%
TOTAL PUBLIC SERVICES	646,797.92	25,695.18	672,493.10	413,817.40	79,855.09	179,820.61	73.3%
235 ENGINEERING							
1 Personnel	187,418.49	1,447.21	188,865.70	149,477.64	0.00	39,388.06	79.1%
2 Expenses	483,100.00	66,774.51	549,874.51	310,820.34	193,129.81	45,924.36	91.6%
TOTAL ENGINEERING	670,518.49	68,221.72	738,740.21	460,297.98	193,129.81	85,312.42	88.5%
270 TREASURER							
2 Expenses	6,700,584.00	0.00	6,700,584.00	6,164,353.24	0.00	536,230.76	92.0%
TOTAL TREASURER	6,700,584.00	0.00	6,700,584.00	6,164,353.24	0.00	536,230.76	92.0%
TOTAL Sewer Enterprise Fund	8,017,900.41	93,916.90	8,111,817.31	7,038,468.62	271,984.90	801,363.79	90.1%
6100 Water Enterprise Fund							
230 PUBLIC SERVICES							



FOR 2021 10

6100 Water Enterprise Fund ORIGINAL APPROP	TRANS/ADJSMTS	REVISED BUDGET	YTD EXPENDED	ENCUMBRANCES	AVAILABLE BUDGET	% USED	
1 Personnel	521,798.09	3,450.12	525,248.21	373,759.01	0.00	151,489.20	71.2%
2 Expenses	171,650.00	3,894.25	175,544.25	93,543.32	64,473.50	17,527.43	90.0%
TOTAL PUBLIC SERVICES	693,448.09	7,344.37	700,792.46	467,302.33	64,473.50	169,016.63	75.9%
235 ENGINEERING							
1 Personnel	185,418.49	1,447.21	186,865.70	149,478.83	0.00	37,386.87	80.0%
2 Expenses	522,350.00	12,352.61	534,702.61	375,269.78	101,397.67	58,035.16	89.1%
TOTAL ENGINEERING	707,768.49	13,799.82	721,568.31	524,748.61	101,397.67	95,422.03	86.8%
270 TREASURER							
2 Expenses	5,045,972.00	0.00	5,045,972.00	4,892,391.67	0.00	153,580.33	97.0%
TOTAL TREASURER	5,045,972.00	0.00	5,045,972.00	4,892,391.67	0.00	153,580.33	97.0%
TOTAL Water Enterprise Fund	6,447,188.58	21,144.19	6,468,332.77	5,884,442.61	165,871.17	418,018.99	93.5%
6200 Solid Waste Enterprise							
235 ENGINEERING							
1 Personnel	96,363.60	705.34	97,068.94	54,617.41	0.00	42,451.53	56.3%
2 Expenses	3,779,835.60	32,834.60	3,812,670.20	2,710,271.41	1,068,579.87	33,818.92	99.1%
TOTAL ENGINEERING	3,876,199.20	33,539.94	3,909,739.14	2,764,888.82	1,068,579.87	76,270.45	98.0%



FOR 2021 10

6200 Solid Waste Enterprise	ORIGINAL APPROP	TRANS/ADJSMTS	REVISED BUDGET	YTD EXPENDED	ENCUMBRANCES	AVAILABLE BUDGET	% USED
TOTAL Solid Waste Enterprise	3,876,199.20	33,539.94	3,909,739.14	2,764,888.82	1,068,579.87	76,270.45	98.0%
6300 COMCAST PEG ACCESS ENTERPRISE							
260 SOLICITOR-LICENSING							
2 Expenses	0.00	691,250.00	691,250.00	451,629.91	0.00	239,620.09	65.3%
TOTAL SOLICITOR-LICENSING	0.00	691,250.00	691,250.00	451,629.91	0.00	239,620.09	65.3%
TOTAL COMCAST PEG ACCESS ENTERPRISE	0.00	691,250.00	691,250.00	451,629.91	0.00	239,620.09	65.3%
GRAND TOTAL	18,341,288.19	839,851.03	19,181,139.22	16,139,429.96	1,506,435.94	1,535,273.32	92.0%

** END OF REPORT - Generated by Anna Freedman **



City of Salem

FY 2021 MONTHLY FINANCIAL REPORTS

May 2021

REPORTS

FUND BALANCES

REVENUE STATEMENT	STABILIZATION	\$ 7,832,043.41
CIP, SALE OF CITY PROPERTY & RETIREMENT STABILIZATION	CAPITAL OUTLAY	\$ 116,653.90
FREE CASH, ENTERPRISE RE	SALE OF CITY PROP	\$ 11,791.50
DEPARTMENTAL BUDGET REPORTS	RETIREMENT STAB	\$ 134,687.63
BUDGET TRANSFER DETAIL -	OPEB	\$ 3,504,740.58
	*FREE CASH	\$ 7,137,398.72
	*WATER & SEWER R/E	\$ 301,226.00
	*TRASH R/E	\$ 73,365.00

*FY20 Free Cash and Retained Earnings Certified by DOR less appropriations to date

CITY OF SALEM
May 31, 2021
REVENUE STATEMENT

GENERAL FUND

REAL AND PERSONAL (NET) 107,304,006 2,824,154 106,633,572 99.38% (667,434)

	RECAP FY 2021	ACTUAL MONTH TO DATE	ACTUAL YEAR TO DATE	Y-T-D % COLLECTED	VARIANCE Y-T-D + (-)
MOTOR VEHICLE	4,100,000	-	3,825,742	93.31%	(274,258)
HOTEL EXCISE	350,000	(1)	393,605	112.46%	43,605
MEALS TAX	400,000	-	683,530	170.88%	283,530
OTHER	500,000	-	0	0.00%	(500,000)
VESSEL EXCISE*	30,000	50	61,454	204.85%	31,454
CANNABIS CBA	500,000	217,989	1,191,511	238.30%	691,511
CANNABIS EXCISE	400,000	-	803,143	200.79%	403,143
INTEREST ON TAXES	400,000	154,189	648,482	162.12%	248,482
PAYMENT IN LIEU OF TAXES (PILOT)	700,000	-	751,556	107.37%	51,556
CHARGES FOR SERVICES	1,600,000	184,916	2,685,322	167.83%	1,085,322
PARKING FEES	1,500,000	232,187	2,269,698	151.31%	769,698
LICENSES AND PERMITS	172,500	(159,956)	333,316	193.23%	160,816
FINES AND FORFEITS	600,000	84,811	966,277	161.05%	366,277
INVESTMENT INCOME	171,750	8,270	152,712	88.92%	(19,038)
MISCELLANEOUS INCOME	230,000	230,000	890,356	387.11%	660,356
MEDICAID INCOME SCHOOL SPED	450,000	32,311	238,510	53.00%	(211,490)
NON RECURRING	0	-	186,836	#DIV/0!	186,836
TOTAL LOCAL RECEIPTS	12,104,250	754,768	16,082,051	132.86%	3,977,801

NET MA CHERRY SHEET ASST.	34,120,336	2,932,141	31,429,490	92.11%	(2,690,846)
MSBA REIMBURSEMENTS	0	-	-	#DIV/0!	0
R/RES REDUCE TAX RATE	975,000	-	975,000	100.00%	0
OFS/TRANSFERS IN	0	1,135,872	1,335,862	#DIV/0!	1,335,862
INDIRECT COSTS from W&S	1,494,176	-	1,494,176	100.00%	0
TOTAL OTHER RECEIPTS	36,589,512	4,068,013	35,234,528	96.30%	(1,354,984)
GENERAL FUND TOTAL	155,994,768	7,646,934	157,950,152	101.25%	1,955,384

ENTERPRISE FUND

SEWER RATES	10,165,959	748,293	9,610,014	94.53%	(555,945)
SEWER TRANS/OFS	-	-	-	#DIV/0!	0
WATER RATES	5,795,306	397,083	5,419,921	93.52%	(375,385)
WATER TRANS/OFS	-	-	-	0	0
Total Water & Sewer	15,961,265	1,145,376	15,029,934	94.17%	(931,331)

TRASH FEES	899,925	72,829	876,279	97.37%	(23,646)
TRASH General Fund Subsidy/OFS	2,976,274	-	2,976,274	100.00%	0
Total Trash	3,876,199	72,829	3,852,553	99.39%	(23,646)

PEG ACCESS	691,250	147,490	636,564	92.09%	(54,686)
Total Peg Access	691,250	147,490	636,564	92.09%	(54,686)
ENTERPRISE FUND TOTAL	20,528,714	1,365,695	19,519,051	95.08%	(1,009,663)
GRAND TOTAL	176,523,482	9,012,629	177,469,203	100.54%	945,721

*50% of Vessel Excise is transferred to Harbormaster R/Res Fund on 6/30 PER MGL CH60B

**CITY OF SALEM, MASSACHUSETTS
FY 2021 Short Term Capital Improvement Program Activity - Fund 2000**

Department	Description	Org/Obj	Date	Pending Amount	Date	CO #	Approved Amount	Repurposed and/or TF In	Y-T-D Paid	Outstanding Balance
------------	-------------	---------	------	----------------	------	------	-----------------	-------------------------	------------	---------------------

Prior to FY2020 - Open Projects

192,225.73

FY 2020 - Open Projects										
FY 2020 Beginning Balance 2,836,684.03										
City Clerk	Vault Storage	20002003-5846BA	5/23/2019		06/25/19		(51,125.00)		51,125.00	-
Fire	SCBA Equipment	20002010-5846BB	5/23/2019		06/25/19		(24,940.00)		16,363.64	8,576.36
Fire	Bldg Maint/Upgrades	20002010-5846BC	5/23/2019		06/25/19		(30,000.00)		21,012.28	8,987.72
Park & Rec	Golf Course Equip	20002017-5846BD	5/23/2019		06/25/19		(55,723.00)		55,600.62	122.38
Park & Rec	SHS Tennis Courts	20002017-5846BE	9/12/2019		9/12/2019	511	(200,000.00)		199,999.96	0.04
Planning	Gallows Hill Pk Renov Proj	20002020-5846BF	9/12/2019		9/12/2019	510	(350,000.00)		218,388.48	131,601.52
Park & Rec	Naumkeag/Pioneer Study	20002017-5846BG	12/5/2019		12/5/2019	715	(100,000.00)		71,225.25	28,774.75
Police	Elevator Repair	20002021-5846BH	2/13/2020		2/13/2020	62	(6,746.00)		6,746.00	-
Fire	Heating System Replacement/Repair	20002010-5846BI	2/13/2020		2/13/2020	62	(23,145.00)		23,145.00	-
Fire	Antenna	20002010-5846BJ	2/13/2020		2/13/2020	62	(24,250.00)	(30,000.00)	31,928.78	22,321.22
Planning	Highland Ave Study	20002020-5846BK	2/13/2020		2/27/2020	59	(40,000.00)	40,000.00	-	-
Electric	Leslie Retreat Park	20002008-5846BL	2/27/2020		2/27/2020	137	(15,680.59)		-	15,680.59
DPS	Salt Shed Study	20002023-5846BM	3/12/2020		3/12/2020	165	(30,000.00)		27,243.46	2,756.54
DPS	Roof Repair	20002023-5846BN	3/12/2020		3/12/2020	163	(175,000.00)		173,621.86	1,378.14
Health	Mack Park Farm	20002012-5846BO	4/9/2020		4/9/2020	208	(20,000.00)		19,800.00	200.00
Veterans	Riley Plaza Flag Pole Repair	20002028-5846BP	4/23/2020		4/23/2020	241	(2,840.08)		-	2,840.08
Engineering	McGrath Park Soils Investigation	20002029-5846BQ	4/23/2020		4/23/2020	239	(20,000.00)		7,284.57	12,715.43
Planning	Beverly-Salem Climate Action Plan	20002020-5846BR	5/28/2020		5/28/2020	274	(32,000.00)		32,000.00	-
Park & Rec	Bertram Field	20002017-5846BS	6/25/2020		6/25/2020	322	(391,140.00)		150,360.00	240,780.00
Park & Rec	Pioneer Village/Camp Naumkeag recaf	20002017-5846BG	7/9/2020		9/10/2020	349	(130,000.00)		-	130,000.00
Planning	Common Fence Restoration	20002020-5846BU	7/9/2020		9/10/2020	359	(80,000.00)		-	80,000.00

FY 2021 - Open Projects

FY 2021 Beginning Balance 1,034,094.36

Library	Main Elevator Repair	20002114-5846CA	11/19/2020		11/19/20	483	(7,458.00)		7,458.00	-
Library	Fire Alarm System	20002114-5846CB	1/28/2021		01/28/21	34	(4,950.00)		4,950.00	-
Engineering	Essex Street Roadway and Sidewalk	20002129-5846CC	2/25/2021		02/25/21	65	(200,000.00)		596.40	199,403.60
School	Bentley Academy Innovation	20002125-5846CD	3/11/2021		03/11/21	112	(124,121.00)		36,138.43	87,982.57
City Council	Furnishing Repairs and Restoration	20002103-5846CE	3/25/2021		03/25/21	143	(18,795.00)		13,747.50	5,047.50
Traffic & Parkin	Garage Equipment Upgrade	20002118-5846CF	3/25/2021		03/25/21	139	(175,000.00)		175,000.00	-
Traffic & Parkin	Bike Share program equipment	20002118-5846CG	3/25/2021		04/22/21	140	(50,000.00)		50,000.00	-
P&R	WH Furniture & Fixtures	20002117-5846CH	3/25/2021		03/25/21	142	(4,000.00)		4,000.00	-
Engineering	WS Emergency	20002129-5846CI	4/22/2021		04/22/21	198	(37,441.46)		37,441.46	-
Traffic & Parkin	Garage Public Restrooms	20002118-5846CJ	4/22/2021		04/22/21	197	(250,000.00)		250,000.00	-
DPS/Engineerit	DPS Facility Fuel Canopy	20002129-5846CK	4/22/2021		04/22/21	203	(15,675.00)		15,675.00	-
Planning	Artist Row Bathroom Upgrade	20002120-5846CL	4/22/2021		04/22/21	200	(30,000.00)		30,000.00	-

FY 2021 Pending Total

-

116,653.90 Total Open Balances

1,735,439.26

221 YTD Balance

116,653.90

Total Open Balances

1,852,093.16

Pending Balance -->

116,653.90

Total Munits Fund Bal

1,852,093.16

**CITY OF SALEM, MASSACHUSETTS
FY 2021 FREE CASH SUMMARY**

Description	Date To Council	Pending Free Cash	Date Approved	C.O. #	Approved Free Cash	Reason
REMAINING FY19 CERTIFIED FREE CASH						
					\$ 1,766,631.00	

1-3245

FC to Set FY 2021 Tax Rate	12/03/20		12/03/20	522	(500,000.00)	TF to Set FY 2021 Tax Rate
FC to HR Contract Services	12/03/20		12/03/20	529	(10,000.00)	To cover shortfall in uniforms expenses
FC to TEF Cannabis 1%	12/03/20		12/03/20	525	(75,000.00)	Transit Enhancement Fund Cannabis 1%
FC TF to Police 12102-53220	12/03/20		12/03/20	528	(30,000.00)	Transfer for the Police Chief Assessment

Revoled as required by DOR, 07/09/20 vote is considered cancelled by the DOR
Revoled as required by DOR, 07/09/20 vote is considered cancelled by the DOR

**TOTAL FY19 FREE CASH USED IN
FY21**

(615,000.00)

[allowed due to COVID-19 temporary law changes]

This amount was then applied to reduce FY20 Free Cash per requirements by the DOR.

FY20 CERTIFIED FREE CASH

\$ 8,951,313.00

1-3245

FC to Mack park	01/14/21		01/14/21	922	(20,000.00)	Closing and Opening of the Farm
FC to COA Vehicle Maintenance	01/14/21		01/14/21	923	(7,000.00)	Vehicle Maintenance
FC to Retirement Stabilization Fund	01/28/21		01/28/21	33	(350,000.00)	Replenish Retirement Stabilization
FC TF to DPS 14111-5111	02/11/21		02/11/21	66	(83,714.28)	Restore budget cuts
FC to Retirement Stabilization Fund	03/25/21		03/25/21	135	(350,000.00)	Replenish Retirement Stabilization
FC to Charter St Cemetery Welcome	03/25/21		03/25/21	141	(40,000.00)	Start-Up Costs for Welcome Center
FC to Contracted Services - Wetlands	04/22/21		04/22/21	199	(30,000.00)	Local wetlands protection policy updates
FC to Police Training/Education	04/22/21		04/22/21	201	(23,200.00)	Recruit training
FC to Fire Dept - VOC alarm	04/22/21		04/22/21	202	(20,000.00)	VOC voice alarm dispatch system
FC to Engineering FY21 Water	05/27/21		05/27/21	263	(890,000.00)	Highland Ave Water Main
Highland CIP	05/27/21		05/27/21	264	-	Revoite of CO922 - \$20,000
FC to Fire Dept - VOC alarm	05/27/21		05/27/21	264	-	Revoite of CO202 - \$20,000
FC to Police Training/Education	05/27/21		05/27/21	264	-	Revoite of CO201 - \$23,200
FC to Contracted Services - Wetlands	05/27/21		05/27/21	264	-	Revoite of CO199 - \$30,000
FC to Charter St Cemetery Welcome	05/27/21		05/27/21	264	-	Revoite of CO141 - \$40,000
FC to Retirement Stabilization Fund	05/27/21		05/27/21	264	-	Revoite of CO33 - \$350,000
FC to Retirement Stabilization Fund	05/27/21		05/27/21	264	-	Revoite of CO135 - \$350,000
FC TF to DPS 14111-5111	05/27/21		05/27/21	264	-	Revoite of CO66 - \$83,714
FC to COA Vehicle Maintenance	05/27/21		05/27/21	264	-	Revoite of CO923 - \$7,000
FC to City Council Advertising	05/27/21		05/27/21	265	(15,000.00)	Public meeting advertising
FC to Police Radio/Vehicle	05/27/21		05/27/21	266	(10,000.00)	Repairs costs
FC to P&R Renovation/Repairs	05/27/21		05/27/21	267	(4,000.00)	Community Life Center signage
FC to General Stabilization	06/10/21		06/10/21	299	(1,790,262.60)	Free Cash Policy 20%
FC to CIP Fund 2000	06/10/21		06/10/21	299	(1,790,262.60)	Free Cash Policy 20%
FC to OPEB Fund	06/10/21		06/10/21	299	(447,565.65)	free Cash Policy 5%

TOTAL FREE CASH USED

\$ -

\$ 6,871,005.13

REMAINING BALANCE

\$ 3,080,307.87

DOR required that this be revoled. Revoled 5/27/21
DOR required that this be revoled. Revoled 5/27/21
DOR required that this be revoled. Revoled 5/27/21
DOR required that this be revoled. Revoled 5/27/21
DOR required that this be revoled. Revoled 5/27/21
DOR required that this be revoled. Revoled 5/27/21
DOR required that this be revoled. Revoled 5/27/21
DOR required that this be revoled. Revoled 5/27/21
DOR required that this be revoled. Revoled 5/27/21
DOR required that this be revoled. Revoled 5/27/21
DOR required that this be revoled. Revoled 5/27/21
DOR required that this be revoled. Revoled 5/27/21
DOR required that this be revoled. Revoled 5/27/21
DOR required that this be revoled. Revoled 5/27/21
DOR required that this be revoled. Revoled 5/27/21
DOR required that a previous order that transferred from water/sewer retained earnings be revoled. This motion reflects that re-approval and is modified to transfer from Free Cash as the certified retained earnings for the Water/Sewer Funds were insufficient to support this transfer.



FOR 2021 11

	ORIGINAL APPROP	TRANS/ADJSMTS	REVISED BUDGET	YTD EXPENDED	ENCUMBRANCES	AVAILABLE BUDGET	% USED
010 ASSESSORS							
1 Personnel							
2 Expenses	316,033.87	2,357.67	318,391.54	274,192.70	0.00	44,198.84	86.1%
	55,400.00	0.00	55,400.00	53,600.16	90.00	1,709.84	96.9%
TOTAL ASSESSORS	371,433.87	2,357.67	373,791.54	327,792.86	90.00	45,908.68	87.7%
030 CITY CLERK							
1 Personnel							
2 Expenses	591,143.03	9,986.53	601,129.56	536,778.76	0.00	64,350.80	89.3%
	145,615.00	16,885.90	162,500.90	120,033.42	19,097.78	23,369.70	85.6%
TOTAL CITY CLERK	736,758.03	26,872.43	763,630.46	656,812.18	19,097.78	87,720.50	88.5%
040 COLLECTOR							
1 Personnel							
2 Expenses	238,335.06	298.54	238,633.60	216,866.18	0.00	21,767.42	90.9%
	7,600.00	281.17	7,881.17	6,162.76	1,078.41	640.00	91.9%
TOTAL COLLECTOR	245,935.06	579.71	246,514.77	223,028.94	1,078.41	22,407.42	90.9%
060 COUNCIL ON AGING							
1 Personnel							
2 Expenses	476,050.43	3,189.71	479,240.14	363,230.44	0.00	116,009.70	75.8%
	82,450.00	7,828.91	90,278.91	32,004.65	29,354.25	28,920.01	68.0%

FOR 2021 11

	ORIGINAL APPROP	TRANS/ADJSTMS	REVISED BUDGET	YTD EXPENDED	ENCUMBRANCES	AVAILABLE BUDGET	% USED
TOTAL COUNCIL ON AGING	558,500.43	11,018.62	569,519.05	395,235.09	29,354.25	144,929.71	74.6%
070 INFORMATION TECHNOLOGY-GIS							
1 Personnel	736,710.05	5,791.04	742,501.09	618,144.12	0.00	124,356.97	83.3%
2 Expenses	781,558.00	17,953.47	799,511.47	582,158.16	200,724.52	16,628.79	97.9%
TOTAL INFORMATION TECHNOLOGY-GIS	1,518,268.05	23,744.51	1,542,012.56	1,200,302.28	200,724.52	140,985.76	90.9%
080 ELECTRICAL							
1 Personnel	380,187.37	3,352.40	383,539.77	331,304.75	0.00	52,235.02	86.4%
2 Expenses	412,940.00	1,218.94	414,158.94	312,221.95	10,457.18	91,479.81	77.9%
TOTAL ELECTRICAL	793,127.37	4,571.34	797,698.71	643,526.70	10,457.18	143,714.83	82.0%
090 FINANCE/AUDITING							
1 Personnel	340,815.88	2,556.66	343,372.54	318,365.71	0.00	25,006.83	92.7%
2 Expenses	52,145.00	928.16	53,073.16	5,573.60	1,193.54	46,306.02	12.8%
TOTAL FINANCE/AUDITING	392,960.88	3,484.82	396,445.70	323,939.31	1,193.54	71,312.85	82.0%
100 FIRE							
1 Personnel	8,992,847.35	133,341.78	9,126,189.13	7,851,851.69	0.00	1,274,337.44	86.0%

FOR 2021 11

	ORIGINAL APPROP	TRANS/ADJSMTS	REVISED BUDGET	YTD EXPENDED	ENCUMBRANCES	AVAILABLE BUDGET	% USED
2 Expenses	497,017.00	20,000.00	517,017.00	345,811.41	88,742.89	82,462.70	84.1%
TOTAL FIRE	9,489,864.35	153,341.78	9,643,206.13	8,197,663.10	88,742.89	1,356,800.14	85.9%
110 HARBORMASTER							
1 Personnel	326,928.51	1,784.11	328,712.62	277,099.56	0.00	51,613.06	84.3%
2 Expenses	44,100.00	0.00	44,100.00	29,821.13	12,506.78	1,772.09	96.0%
TOTAL HARBORMASTER	371,028.51	1,784.11	372,812.62	306,920.69	12,506.78	53,385.15	85.7%
120 HEALTH DEPT							
1 Personnel	495,563.14	4,111.31	499,674.45	433,185.13	0.00	66,489.32	86.7%
2 Expenses	58,029.00	20,299.45	78,328.45	34,807.74	7,090.69	36,430.02	53.5%
TOTAL HEALTH DEPT	553,592.14	24,410.76	578,002.90	467,992.87	7,090.69	102,919.34	82.2%
130 HUMAN RESOURCES							
1 Personnel	16,466,964.03	153,676.69	16,620,640.72	14,493,978.33	308,766.64	1,817,895.75	89.1%
2 Expenses	13,750.00	19,275.31	33,025.31	21,426.44	1,676.01	9,922.86	70.0%
TOTAL HUMAN RESOURCES	16,480,714.03	172,952.00	16,653,666.03	14,515,404.77	310,442.65	1,827,818.61	89.0%
140 LIBRARY							

FOR 2021 11

140 LIBRARY	ORIGINAL APPROP	TRANS/ADJSMTS	REVISED BUDGET	YTD EXPENDED	ENCUMBRANCES	AVAILABLE BUDGET	% USED
1 Personnel	1,058,785.82	22,761.47	1,081,547.29	840,099.59	0.00	241,447.70	77.7%
2 Expenses	289,282.00	5,000.00	294,282.00	261,504.39	31,046.73	1,730.88	99.4%
TOTAL LIBRARY	1,348,067.82	27,761.47	1,375,829.29	1,101,603.98	31,046.73	243,178.58	82.3%
<hr/>							
160 MAYOR							
1 Personnel	420,500.57	3,286.83	423,787.40	376,275.99	0.00	47,511.41	88.8%
2 Expenses	146,550.00	48,272.26	194,822.26	144,867.49	43,563.20	6,391.57	96.7%
TOTAL MAYOR	567,050.57	51,559.09	618,609.66	521,143.48	43,563.20	53,902.98	91.3%
<hr/>							
170 RECREATION							
1 Personnel	1,022,972.53	27,545.40	1,050,517.93	812,007.66	0.00	238,510.27	77.3%
2 Expenses	623,743.00	47,353.27	671,096.27	429,377.90	131,012.26	110,706.11	83.5%
TOTAL RECREATION	1,646,715.53	74,898.67	1,721,614.20	1,241,385.56	131,012.26	349,216.38	79.7%
<hr/>							
180 TRAFFIC & PARKING DEPT							
1 Personnel	852,853.11	22,330.55	875,183.66	754,488.82	0.00	120,694.84	86.2%
2 Expenses	350,795.00	96,173.77	446,968.77	372,055.21	58,085.10	16,828.46	96.2%
TOTAL TRAFFIC & PARKING DEPT	1,203,648.11	118,504.32	1,322,152.43	1,126,544.03	58,085.10	137,523.30	89.6%
<hr/>							
200 PLANNING							

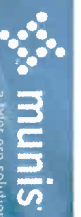

FOR 2021 11

200 PLANNING	ORIGINAL APPROP	TRANS/ADJSTMS	REVISED BUDGET	YTD EXPENDED	ENCUMBRANCES	AVAILABLE BUDGET	% USED
1 Personnel	618,150.62	23,436.69	641,587.31	550,753.07	0.00	90,834.24	85.8%
2 Expenses	366,263.00	86,324.82	452,587.82	292,668.00	108,672.43	51,247.39	88.7%
TOTAL PLANNING	984,413.62	109,761.51	1,094,175.13	843,421.07	108,672.43	142,081.63	87.0%
<hr/>							
210 POLICE							
1 Personnel	10,012,200.82	5,433.85	10,017,634.67	8,330,428.80	0.00	1,687,205.87	83.2%
2 Expenses	693,202.00	64,298.35	757,500.35	640,955.13	65,038.11	51,507.11	93.2%
TOTAL POLICE	10,705,402.82	69,732.20	10,775,135.02	8,971,383.93	65,038.11	1,738,712.98	83.9%
<hr/>							
220 PUBLIC PROPERTY							
1 Personnel	630,166.34	5,198.51	635,364.85	519,472.23	0.00	115,892.62	81.8%
2 Expenses	739,200.00	33,488.54	772,688.54	655,330.99	94,111.41	23,246.14	97.0%
TOTAL PUBLIC PROPERTY	1,369,366.34	38,687.05	1,408,053.39	1,174,803.22	94,111.41	139,138.76	90.1%
<hr/>							
230 PUBLIC SERVICES							
1 Personnel	1,842,775.51	95,816.81	1,938,592.32	1,498,408.90	0.00	440,183.42	77.3%
2 Expenses	1,715,631.00	191,892.25	1,907,523.25	2,249,999.01	957,190.03	-1,299,665.79	168.1%
TOTAL PUBLIC SERVICES	3,558,406.51	287,709.06	3,846,115.57	3,748,407.91	957,190.03	-859,482.37	122.3%
<hr/>							
235 ENGINEERING							

FOR 2021 11

235 ENGINEERING	ORIGINAL APPROP	TRANS/ADJSTMS	REVISED BUDGET	YTD EXPENDED	ENCUMBRANCES	AVAILABLE BUDGET	% USED
1 Personnel	172,151.85	1,336.23	173,488.08	176,304.44	0.00	-2,816.36	101.6%
2 Expenses	16,800.00	1.77	16,801.77	3,546.87	7,765.18	5,489.72	67.3%
TOTAL ENGINEERING	188,951.85	1,338.00	190,289.85	179,851.31	7,765.18	2,673.36	98.6%
240 PURCHASING							
1 Personnel	155,110.61	1,132.76	156,243.37	134,442.35	0.00	21,801.02	86.0%
2 Expenses	95,701.00	178.53	95,879.53	74,785.18	16,924.67	4,169.68	95.7%
TOTAL PURCHASING	250,811.61	1,311.29	252,122.90	209,227.53	16,924.67	25,970.70	89.7%
250 SCHOOL							
1 Personnel	49,779,685.77	439,457.00	50,219,142.77	38,453,702.41	0.00	11,765,440.36	76.6%
2 Expenses	13,669,963.28	578,557.90	14,248,521.18	9,740,699.48	2,418,527.62	2,089,294.08	85.3%
TOTAL SCHOOL	63,449,649.05	1,018,014.90	64,467,663.95	48,194,401.89	2,418,527.62	13,854,734.44	78.5%
260 SOLICITOR-LICENSING							
1 Personnel	303,922.10	2,289.46	306,211.56	271,968.48	0.00	34,243.08	88.8%
2 Expenses	78,600.00	0.00	78,600.00	30,140.65	25,623.51	22,835.84	70.9%
TOTAL SOLICITOR-LICENSING	382,522.10	2,289.46	384,811.56	302,109.13	25,623.51	57,078.92	85.2%
270 TREASURER							

FOR 2021 11

270 TREASURER ORIGINAL APPROP TRANS/ADJSMTS REVISED BUDGET YTD EXPENDED ENCUMBRANCES AVAILABLE BUDGET % USED

1 Personnel	14,305,994.39	13,778.57	14,319,772.96	14,112,305.41	0.00	207,467.55	98.6%
2 Expenses	19,532,465.00	-139,800.18	19,392,664.82	17,466,435.71	4,859.64	1,921,369.47	90.1%
TOTAL TREASURER	33,838,459.39	-126,021.61	33,712,437.78	31,578,741.12	4,859.64	2,128,837.02	93.7%

280 VETERANS SERVICES

1 Personnel	117,287.61	919.58	118,207.19	105,413.49	0.00	12,793.70	89.2%
2 Expenses	411,550.00	0.00	411,550.00	295,499.42	3,036.70	113,013.88	72.5%
TOTAL VETERANS SERVICES	528,837.61	919.58	529,757.19	400,912.91	3,036.70	125,807.58	76.3%

900 BUDGET TRANSFERS OUT OF GF

2 Expenses	625,000.00	0.00	625,000.00	0.00	0.00	625,000.00	.0%
TOTAL BUDGET TRANSFERS OUT OF GF	625,000.00	0.00	625,000.00	0.00	0.00	625,000.00	.0%

GRAND TOTAL
152,159,485.65 2,101,582.74 154,261,068.39 126,852,555.86 4,646,235.28 22,762,277.25 85.2%

** END OF REPORT - Generated by Anna Freedman **

FOR 2021 11

ORIGINAL APPROP	TRANS/ADJSMTS	REVISED BUDGET	YTD EXPENDED	ENCUMBRANCES	AVAILABLE BUDGET	% USED
6000 Sewer Enterprise Fund						
230 PUBLIC SERVICES						
1 Personnel	466,797.92	3,450.12	470,248.04	337,411.46	0.00	132,836.58 71.8%
2 Expenses	180,000.00	22,245.06	202,245.06	118,476.33	83,768.01	0.72 100.0%
TOTAL PUBLIC SERVICES	646,797.92	25,695.18	672,493.10	455,887.79	83,768.01	132,837.30 80.2%
235 ENGINEERING						
1 Personnel	187,418.49	1,447.21	188,865.70	164,013.80	0.00	24,851.90 86.8%
2 Expenses	483,100.00	66,774.51	549,874.51	339,343.65	163,274.93	47,255.93 91.4%
TOTAL ENGINEERING	670,518.49	68,221.72	738,740.21	503,357.45	163,274.93	72,107.83 90.2%
270 TREASURER						
2 Expenses	6,700,584.00	0.00	6,700,584.00	6,187,665.74	0.00	512,918.26 92.3%
TOTAL TREASURER	6,700,584.00	0.00	6,700,584.00	6,187,665.74	0.00	512,918.26 92.3%
TOTAL Sewer Enterprise Fund	8,017,900.41	93,916.90	8,111,817.31	7,146,910.98	247,042.94	717,863.39 91.2%
6100 Water Enterprise Fund						
230 PUBLIC SERVICES						



FOR 2021 11

6100 Water Enterprise Fund ORIGINAL APPROP	TRANS/ADJSMTS	REVISED BUDGET	YTD EXPENDED	ENCUMBRANCES	AVAILABLE BUDGET	% USED	
1 Personnel	521,798.09	3,450.12	525,248.21	410,614.52	0.00	114,633.69	78.2%
2 Expenses	171,650.00	3,894.25	175,544.25	112,307.13	63,235.47	1.65	100.0%
TOTAL PUBLIC SERVICES	693,448.09	7,344.37	700,792.46	522,921.65	63,235.47	114,635.34	83.6%
235 ENGINEERING							
1 Personnel	185,418.49	1,447.21	186,865.70	164,015.06	0.00	22,850.64	87.8%
2 Expenses	522,350.00	12,352.61	534,702.61	404,665.34	84,535.73	45,501.54	91.5%
TOTAL ENGINEERING	707,768.49	13,799.82	721,568.31	568,680.40	84,535.73	68,352.18	90.5%
270 TREASURER							
2 Expenses	5,045,972.00	0.00	5,045,972.00	4,895,888.55	0.00	150,083.45	97.0%
TOTAL TREASURER	5,045,972.00	0.00	5,045,972.00	4,895,888.55	0.00	150,083.45	97.0%
TOTAL Water Enterprise Fund	6,447,188.58	21,144.19	6,468,332.77	5,987,490.60	147,771.20	333,070.97	94.9%
6200 Solid Waste Enterprise							
235 ENGINEERING							
1 Personnel	96,363.60	705.34	97,068.94	60,132.21	0.00	36,936.73	61.9%
2 Expenses	3,779,835.60	32,834.60	3,812,670.20	3,046,989.33	735,061.95	30,618.92	99.2%
TOTAL ENGINEERING	3,876,199.20	33,539.94	3,909,739.14	3,107,121.54	735,061.95	67,555.65	98.3%

06/21/2021 10:25
14792fire

CITY OF SALEM, MA - LIVE
YEAR-TO-DATE BUDGET REPORT



FOR 2021 11

6200 Solid Waste Enterprise ORIGINAL APPROP	TRANS/ADJSMTS	REVISED BUDGET	YTD EXPENDED	ENCUMBRANCES	AVAILABLE BUDGET	% USED
TOTAL Solid Waste Enterprise	33,539.94	3,909,739.14	3,107,121.54	735,061.95	67,555.65	98.3%
3,876,199.20						
<hr/>						
6300 COMCAST PEG ACCESS ENTERPRISE						
<hr/>						
260 SOLICITOR-LICENSING						
<hr/>						
2 Expenses	0.00	691,250.00	599,119.54	0.00	92,130.46	86.7%
TOTAL SOLICITOR-LICENSING	0.00	691,250.00	599,119.54	0.00	92,130.46	86.7%
TOTAL COMCAST PEG ACCESS ENTERPRISE	0.00	691,250.00	599,119.54	0.00	92,130.46	86.7%
GRAND TOTAL	18,341,288.19	19,181,139.22	16,840,642.66	1,129,876.09	1,210,620.47	93.7%

** END OF REPORT - Generated by Anna Freedman **



CITY OF SALEM

In City Council, June 24, 2021

Ordered:

Reappointment of City Clerk, Ilene Simons, for a term to expire June 28, 2024



CITY OF SALEM

In City Council, June 24, 2021

Ordered:

In accordance with Massachusetts General Law, Chapter 268A, Section 20(b) the City Council hereby declares that following have met the requirements for exemption as set forth in this Section and may be retained by the City during the 2021 calendar year, not to exceed 500 hours in this calendar year:

<u>Employee</u>	<u>Current Position</u>	<u>Section 20(b) Position</u>
Tomasina Pena	Cafeteria Helper	Neighborhood Ambassador
Ezekiel Holt	Disability Com. Member	Neighborhood Ambassador
Deborah Linskey	Cafeteria Substitute	Seasonal Golf Course Worker



ELIZABETH M. RENNARD

CITY SOLICITOR
93 WASHINGTON STREET
SALEM, MA 01970
TEL: 978.619.5633
FAX: 978.744.1279
EMAIL: BRENNARD@SALEM.COM

VICTORIA B. CALDWELL

ASSISTANT CITY SOLICITOR
93 WASHINGTON STREET
SALEM, MA 01970
TEL: 978.619.5634
FAX: 978.744.1279
EMAIL: VCALDWELL@SALEM.COM

CITY OF SALEM

KIMBERLEY L. DRISCOLL, MAYOR

LEGAL DEPARTMENT
93 WASHINGTON STREET
SALEM, MASSACHUSETTS 01970

June 24, 2021

Salem City Council
City Hall
Salem, MA 01970

Ladies and Gentlemen of the Council:

Enclosed herewith is a proposed Order approving a Massachusetts Conflict of Interest Law exemption for two current employees and one commission member as provided in General Law c. 268A, § 20(b).

The Conflict of Interest Law, specifically General Law c. 268A, § 20(b), requires that because these public officials will provide personal services to the Park, Recreation and Community Services Department and the Mayor's office they must receive City Council approval of a § 20(b) exemption. A copy of the law is attached for your review.

If you have any questions relative to the proposed Order, please contact me at your earliest convenience. Thank you.

Sincerely,

Elizabeth Rennard

Enclosure

CHAPTER 268A. CONDUCT OF PUBLIC OFFICIALS AND EMPLOYEES

Chapter 268A: Section 20. Municipal employees; financial interest in contracts; holding one or more elected positions

Section 20. (a) A municipal employee who has a financial interest, directly or indirectly, in a contract made by a municipal agency of the same city or town, in which the city or town is an interested party of which financial interest he has knowledge or has reason to know, shall be punished by a fine of not more than three thousand dollars or by imprisonment for not more than two years, or both.

This section shall not apply if such financial interest consists of the ownership of less than one per cent of the stock of a corporation.

This section shall not apply (a) to a municipal employee who in good faith and within thirty days after he learns of an actual or prospective violation of this section makes full disclosure of his financial interest to the contracting agency and terminates or disposes of the interest, or (b) to a municipal employee who is not employed by the contracting agency or an agency which regulates the activities of the contracting agency and who does not participate in or have official responsibility for any of the activities of the contracting agency, if the contract is made after public notice or where applicable, through competitive bidding, and if the municipal employee files with the clerk of the city or town a statement making full disclosure of his interest and the interest of his immediate family, and if in the case of a contract for personal services (1) the services will be provided outside the normal working hours of the municipal employee, (2) the services are not required as part of the municipal employee's regular duties, the employee is compensated for not more than five hundred hours during a calendar year, (3) the head of the contracting agency makes and files with the clerk of the city or town a written certification that no employee of that agency is available to perform those services as part of their regular duties, and (4) the city council, board of selectmen or board of aldermen approve the exemption of his interest from this section.

PRESERVATION RESTRICTION AGREEMENT

between

HISTORIC SALEM, INC.

and the

CITY OF SALEM, MASSACHUSETTS

BY AND THROUGH THE SALEM HISTORICAL COMMISSION

THIS PRESERVATION RESTRICTION AGREEMENT is made this ____ day of _____, 2021 by and between HISTORIC SALEM, INC., located at 9 North Street, Salem, Massachusetts ("Grantor") and the CITY OF SALEM ("Grantee"), a municipality duly organized under the laws of the Commonwealth of Massachusetts and located in Essex County, Massachusetts, to be administered, managed and enforced by its agent, the SALEM HISTORICAL COMMISSION, located at 98 Washington Street, Salem, Massachusetts, 01970 ("Commission"),

WHEREAS, the Grantor is the owner of certain real property (hereinafter referred to as "**the Property**") with improvements thereon known as both the Nathaniel Bowditch House (hereinafter referred to as "**the Building**"), located at 9 North Street, Salem, Massachusetts, more particularly described in a deed dated June 7, 2000 from The City of Salem to Historic Salem, Incorporated of Salem, MA and recorded in Essex South Registry of Deeds in Book 16412, Page 578 and in Exhibit A, attached hereto and incorporated herein by this reference. The Property is further described and depicted as "LOT 2" on a plan titled "Plan of Land – Salem, MA prepared for City of Salem" prepared by Hancock Survey Associates, dated June 8, 2000 and recorded in the Essex South Registry of Deeds, Plan Book 344, Plan 37, a copy of which is attached hereto and incorporated herein by this reference as Exhibit B.

WHEREAS, the Building is described as follows, and also depicted in a set of six (6) photographic images taken in December, 2020, referenced by number in the following text, with copies of said images attached hereto and incorporated herein by reference as Exhibit C:

The Building was originally a two-story, side-gable building constructed in c. 1760 by Samuel Curwen. The present third floor was constructed in 1805 alongside other Federal-style alterations. Originally located on the corner of Essex and North streets, it moved to its present location at 9 North Street about 1945 to avoid its demolition and that of the Judge Jonathan Corwin House, 310 Essex Street (1675, SAL.1510, NRDIS 8/28/1973), known as the Salem Witch House, during a street-widening project. Aside from its original foundation, the structure remained intact during the move. The Building underwent a thorough restoration in 2003, including repair or in-kind replacement of Federal Style features.

The timber frame Building is located on the west side of North Street and is an east-facing, three-story, five-bay, hip roofed, Federal Style building (Photo 1). The south (side) elevation facing Essex Street is two bays deep (Photo 2) while the north (side) elevation has one bay (Photo 3). The three-story main block measures 22 by 36 feet with a two-and-one-half-story, half-gambrel, 18' by 18' addition attached to the south end of the west (rear) elevation (Photos 4–5). Fenestration consists of original six-over-six, double hung, wood sashes set in simple molded surrounds with modern one-over-one metal storm windows. Black louvered shutters flank windows on the east (front), north, and south (side) elevations. The east (front) foundation wall consists of flat granite dress stones, set on edge. The side foundation walls are comprised of random-coursed ashlar stones, providing one-wythe veneer facing on a poured concrete foundation.

The exterior walls of the Building are clad with wood clapboard siding, painted blue, and framed by plain, white corner boards. A 1965 National Historic Landmark bronze plaque is affixed to the

north end of the east (front) at the first story. The walls terminate at a shallow, corniced overhang which conceals copper-lined wood gutters. The roof is clad with asphalt shingles, pierced by brick chimneys at the north and south ends of the west (rear) slope, and is bounded by a distinctive five-by-three bay, Chinese Style, wood balustrade that consists of wide panels filled with diagonal rails arranged in a diamond-like pattern. Plain wood posts with slightly recessed bases and coping frame the diamond panels. The balustrade's bottom rails float above the roofline such that the balustrade is structurally independent of the roof.

The five bay façade (east) features a recessed, center entry, flanked by two windows and accessed by three monolithic granite steps bounded by modern metal railings. The entry is recessed about 18 inches into the building, displaying wood panels in the jambs and soffit, and consists of a six-panel, Federal-style door flanked by sidelights and a four-light transom above the door (Photo 6). The doorway is flanked by engaged (1/2 to 3/4 plan) fluted columns, capped by capitals with carved acanthus leaves, projecting Ionic volutes, and roses. The columns support a full entablature that frames the doorway with projecting flat pilasters at each end. The entablature consists of a stepped architrave capped with a bead molding, a plain frieze, and a simple, dentiled and molded cornice with slightly projecting north and south ends that correspond with the supporting columns.

When moved in 1944, the Bowditch House was badly deteriorated and required major wall and floor repairs; removal of post-Bowditch family partitions; and replacement of window lights, doors, and the roof. Despite the extensive work completed, the exterior appearance of the Building remained essentially as it was when constructed (with the exception of the original roof balustrade, removed at an unknown date and not replaced). The 2003 rehabilitation included reconstruction of the balustrade, construction of a new accessibility ramp with Federal Style railing details at the rear, and removal of many other features not in keeping with the Building's early nineteenth century character (front hedges, front railings around the hedges, rear cellar bulkhead, and projecting winter porch). The restored Building is protected by a preservation restriction held by the Massachusetts Historical Commission.

The interior of the Bowditch House follows a standard four-room, center hall plan. Original fabric includes simple moldings around windows and doors, cornice moldings, folding shutters in the former parlor and dining room, and some original fireplaces. Several features (including fireplace surrounds and other decorative casings) were removed in the decades between 1944 and the 1990s. The remaining millwork is tentatively attributed to Samuel McIntire (1757–1811), an acclaimed Salem architect and noted local practitioner of Adamesque architecture and detailing, on the basis of client, location, and style.

WHEREAS, the Building and Property were listed as a National Historic Landmark on October 15, 1966, are a contributing property to the Chestnut Street Historic District listed in the National Register of Historic Places on August 26, 1973, are located within the McIntire Historic District established by the City of Salem on March 3, 1981, are subject to perpetual preservations held by the Massachusetts Historical Commission, recorded at Essex South District Registry of Deeds on February 21, 2003, and as a result of the foregoing is listed in the State Register of Historic Places.

WHEREAS, the Building and Property are historically significant for their architecture, associations, and/or archaeology, and qualify for the protections of perpetual preservation restrictions under M.G.L. Chapter 184, sections 31, 32 and 33 ("Act").

WHEREAS, Grantor and Grantee recognize the architectural, historic, and cultural values (hereinafter "preservation values") and significance of the Building and have the common purpose of preserving the aforesaid preservation values and significance of the exterior of the Building and the Property; and

WHEREAS, the preservation values of the Building and Property are documented in a series of photographs and documents (hereinafter, "Baseline Documentation") incorporated herein and attached

hereto as by reference as Exhibit A, B, C and D, which Baseline Documentation the parties agree provides an accurate representation of the Building and Property as of the date of this grant; and

WHEREAS, the Baseline Documentation (Exhibits A, B, C and D) shall consist of the following:

- Exhibit A. Legal Property Description
- Exhibit B. Recorded Plan
- Exhibit C. Assessors' Parcel Map
- Exhibit D. Six (6) Baseline Photographs dated December 2020.

WHEREAS, the Building and Property is in need of preservation and restoration; and

WHEREAS, upon the recommendation of the Community Preservation Committee and approved as Project by the City Council, the sum of Forty-Three Thousand Dollars (\$43,000) from the Community Preservation Fund ("Funds") was appropriated for the purpose of funding a grant for roof replacement on the Building; and

WHEREAS, the Grantor and the Grantee have reached an Agreement whereby the Grantee shall provide the Funds so appropriated to the Grantor to be expended for the preservation and renovation of the aforementioned Building, under the terms and conditions set forth herein and in such other documents as the parties may execute, and the Grantor agrees to accept such Funds to be used exclusively for such purposes and under such terms and conditions ("Restriction" or "Preservation Restriction");

WHEREAS, the Grantor in further consideration of the receipt of such Funds and to ensure the preservation of the aforementioned Building and Property agrees and desires, to impose certain restrictions, obligations and duties upon itself, its successors and assigns, so as to maintain, protect and preserve the architectural and historical integrity of the Building and Property;

WHEREAS, the preservation of the Building and Property is important to the public for the enjoyment and appreciation of their architectural and historical heritage and serves the public interest in a manner consistent with the purposes of the Act; and

WHEREAS, the Commission is authorized to accept preservation restrictions in the name of the City of Salem and the Commission is a governmental body duly organized under the laws of the Commonwealth of Massachusetts, including the General Laws, Chapter 40C, authorized and directed by the Grantee to manage the Property and Buildings burdened by such restrictions, consistent with the provisions of the Act and to administer and enforce this preservation restriction;

NOW THEREFORE, for good and valuable consideration, the receipt of which is hereby acknowledged, the Grantor does hereby irrevocably grant and convey to the Grantee in gross in perpetuity this Restriction over the Property and exterior of the Building to be administered, managed and enforced by the Commission.

1. Purpose: It is the Purpose of this Restriction to assure that, the architectural, historic, and cultural features of the exterior of the Building will be retained and maintained forever substantially in its current condition or in a restored condition approved by the Commission for preservation purposes and to prevent any use or change of the Property or the exterior of the Building that will significantly impair or interfere with the Building's preservation values or alter views of the exterior of the Building.

2. Preservation Restriction: The Grantor grants the Grantee the right to forbid or limit:

- a. any alteration to the appearance, materials, workmanship, condition or structural stability of the Building unless (i) clearly of a minor nature and not affecting the characteristics which contribute to the architectural or historical integrity of the Building and the Property, or (ii) the Grantee has previously determined that it will not impair such characteristics after reviewing plans and specifications submitted by Grantor in accordance with the requirements of paragraph 7, which

determination shall not be unreasonably withheld, or (iii) required by casualty or other emergency promptly reported to Grantee in accordance with the requirements of paragraph 9. For the purposes of this Agreement, interpretation of what constitutes alterations of a minor nature and ordinary maintenance and repair is governed by the Restriction Guidelines, which are attached hereto as Exhibit E and hereby incorporated by reference.

- b. any other act or use that may be harmful to the historic preservation of the Building or the Property.

3. Restriction as to Expenditure of Funds: Subject to Paragraph 2 and the terms and conditions of this Restriction and such other terms and conditions as the Commission may reasonably impose to accomplish the purposes of this Restriction, the Grantor shall expend such Community Preservation Funds to rehabilitate and restore the Building.

4.1. Grantor's Covenants: Covenant to Maintain. Subject to Paragraph 2 and the terms and conditions of this Restriction and such other terms and conditions as the Commission may reasonably impose to accomplish the purposes of this Restriction, the Grantor covenants and agrees at all times to maintain the Building in the same structural condition and state of repair to that existing following the substantial completion of restoration work to be completed as a result of the expenditure of Community Preservation Funds. Grantor's obligation to maintain shall require replacement, repair, and reconstruction by Grantor whenever necessary to preserve the exterior of the Building. Subject to the casualty provisions of paragraphs 9 and 10, this obligation to maintain shall require replacement, rebuilding, repair, and reconstruction of the Building whenever necessary in accordance with the policies and procedures of the Commission and in accordance with The Secretary of the Interior's Standards for the Treatment of Historic Properties with Guidelines for Preserving, Rehabilitating, Restoring, and Reconstructing Historic Buildings (36 CFR 67 and 68), as these may be amended from time to time (hereinafter the "Secretary's Standards").

4.2. Grantor's Covenants: Prohibited Activities. The following acts or uses are expressly forbidden except as otherwise conditioned in this paragraph:

- a. the Building shall not be demolished, removed, or razed except as provided in Paragraphs 9 and 10;
- b. the dumping of ashes, trash, rubbish, or any other unsightly or offensive materials is prohibited on the Property near the Building;
- c. no above-ground utility transmission lines, except those reasonably necessary for the existing Building, may be created on the Property, subject to utility easements already recorded;
- d. no additions and/or outbuildings may be attached to the Building without prior approval of the Grantee; and
- e. moving the Building to another location shall be forbidden without prior approval of the Commission.

5. Conditional Rights Requiring Grantee Approval: Subject to Paragraph 4 and the terms and conditions of this Restriction and such other terms and conditions as the Commission may reasonably impose to accomplish the purposes of this Restriction, the Grantor shall not alter the Building without prior express written approval of the Commission. Without said approval Grantor shall not make any changes to the Building, including the alteration, partial removal, construction, remodeling, or other physical or structural change, including permanent signs, and any change in material or color or any change to the footprint, size, mass, ridge-line, and rooflines of the Building. Grantor shall similarly not make any alterations to the surrounding Property that would obscure the current view of the Building, such as the installation of permanent signage or trees or very large shrubs without approval of the Commission.

Activities by Grantor to maintain the Building and the Property which are intended to be performed in accordance with the provisions of paragraph 4.1, and which are of a minor nature, shall not require the prior approval of the Commission. For the purposes of this section, interpretation of what constitutes ordinary maintenance of a minor nature is governed by the Restriction Guidelines (Exhibit E), which are attached to this Agreement and hereby incorporated by reference.

6. Grantor's Reserved Rights Not Requiring Further Approval by the Grantee: Subject to the provisions of paragraphs 2 and 4.2, the following rights, uses, and activities of or by Grantor on, over, or under the Property are permitted by this Restriction and by the Commission without further approval by the Commission:

- a. the right to engage in all those acts and uses that:
 - (i) are permitted by governmental statute or regulation;
 - (ii) do not substantially impair the preservation values of the Building and Property; and
 - (iii) are not inconsistent with the Purpose of this Restriction;
- b. pursuant to the provisions of Paragraph 4.1, the right to maintain and repair the Building strictly according to the Secretary's Standards. As used in this sub-paragraph, the right to maintain and repair shall mean the use by the Grantor of in-kind materials and colors, applied with workmanship comparable to that which was used in the construction or application of those materials being repaired or maintained, for the purpose of retaining in good condition the appearance and construction of the exterior of the Building. The right to maintain and repair as used in this sub-paragraph shall not include the right to make changes in appearance, materials, workmanship from that existing prior to the maintenance and repair without the prior approval of the Commission in accordance with the provisions of Paragraph 5;

7. Review of Grantor's Requests for Approval: Grantor shall submit to the Commission for the Commission's approval of those conditional rights set out at Paragraphs 2 and 5 and two copies of information (including plans, specifications, and designs where appropriate) identifying the proposed activity with reasonable specificity. In connection therewith, Grantor shall also submit to the Commission a timetable for the proposed activity sufficient to permit the Commission to monitor such activity. Within sixty (60) days of the Commission's receipt of any plan or written request for approval hereunder, the Commission shall certify in writing that (a) it approves the plan or request, or (b) it disapproves the plan or request as submitted, in which case the Commission shall provide Grantor with written suggestions for modification or a written explanation for the Commission's disapproval. Any failure by the Commission to act within sixty (60) days of receipt of Grantor's submission or resubmission of plans or requests shall be deemed to constitute approval by the Commission of the plan or request as submitted and to permit Grantor to undertake the proposed activity in accordance with the plan or request submitted, so long as the request sets forth the provisions of this section relating to deemed approval after the passage of time provided that nothing herein shall be construed to permit Grantor from undertake any of the activities prohibited hereunder.

8. Standards for Review: In exercising any authority created by this Restriction to inspect the Building; to review any construction, alteration, repair, or maintenance; or to review casualty damage or to reconstruct or approve reconstruction of the Building following casualty damage, the Commission shall apply the Secretary's Standards.

9. Casualty Damage or Destruction: In the event that Building or Property shall be damaged or destroyed by fire, flood, windstorm, hurricane, earth movement or other casualty, Grantor shall notify the Commission in writing within fourteen (14) days of the damage or destruction, such notification including what, if any, emergency work has already been completed. No repairs or reconstruction of any type, other than temporary emergency work to prevent further damage to the Building and Property and to protect public safety, shall be undertaken by Grantor without the Commission's prior written approval of the work. Within sixty (60) days of the date of damage or destruction, if required by the Commission, Grantor at its expense shall submit to the Commission a written report prepared by a qualified restoration

architect and an engineer who are acceptable to the Grantor and the Commission, which report shall include the following:

- a. an assessment of the nature and extent of the damage;
- b. a determination of the feasibility of the restoration of the Building and/or reconstruction of damaged or destroyed portions of the Building; and
- c. a report of such restoration/reconstruction work necessary to return the Building to the condition existing at the date hereof or the condition subsequently approved by the Commission.

10. Review After Casualty Damage or Destruction: If, after reviewing the report provided in Paragraph 9 and assessing the availability of insurance proceeds after satisfaction of any mortgagee's/lender's claims under paragraph 11, Grantor and the Commission agree that the Purpose of the Restriction will be served by such restoration/reconstruction, Grantor and the Commission shall establish a schedule under which Grantor shall complete the restoration/reconstruction of the Building in accordance with plans and specifications consented to by the parties up to at least the total of the casualty insurance proceeds available to Grantor.

If, after reviewing the report and assessing the availability of insurance proceeds after satisfaction of any mortgagee's/lender's claims under paragraph 11, Grantor and the Commission agree that restoration/reconstruction of the Building is impractical or impossible, or agree that the Purpose of the Restriction would not be served by such restoration/reconstruction and Grantor may, with prior written consent of the Commission, alter, demolish, remove or raze the Building, and/or construct new improvements on the Property. Grantor and Grantee may agree to seek to extinguish this Restriction in accordance with the laws of the Commonwealth of Massachusetts and paragraph 23 hereof.

If, after reviewing the report and assessing the availability of insurance proceeds after satisfaction of any mortgagee's/lender's claims under paragraph 11, Grantor and the Commission are unable to agree that the Purpose of the Restriction will or will not be served by such restoration/reconstruction, the matter may be referred by either party to binding arbitration and settled in accordance with the Commonwealth of Massachusetts arbitration statute then in effect, and all other applicable laws, rules, regulations, and ordinances. Arbitrator shall have experience in historic preservation matters.

11. Insurance: Grantor shall keep the Building insured by an insurance company rated "A" or better by Best's or equivalent rating agency for the full replacement value against loss from the perils commonly insured under standard fire and extended coverage policies and comprehensive general liability insurance against claims for personal injury, death and property damage. Property damage insurance shall include change in condition and building ordinance coverage, in form and amount sufficient to replace fully the damaged Building without cost or expense to Grantor or contribution or coinsurance from Grantor. Grantor shall deliver to the Commission, within ten (10) business days of the Commission's written request thereof, certificates of such insurance coverage. Provided, however, that whenever the Property is encumbered with a mortgage or deed of trust nothing contained in this paragraph shall jeopardize the prior claim, if any, of the mortgagee/lender to the insurance proceeds.

12. Indemnification: Grantor hereby agrees to pay, protect, indemnify, hold harmless and defend, at its own cost and expense, Grantee, its boards, commissions, appointees, agents, directors, employees, or independent contractors from and against any and all claims, liabilities, expenses, costs, damages, losses and expenditures (including attorneys' fees and disbursements hereafter incurred) arising out of or in connection with injury to or death of any person as a result of the existence of this Restriction; physical damage to the Building; the presence or release in, on, or about the Property, at any time, of any substance now or hereafter defined, listed, or otherwise classified pursuant to any law, ordinance or regulation as a hazardous, toxic, polluting or contaminating substance; or other injury or other damage occurring on or about the Building; unless such injury, death, or damage is caused by Grantee or its boards, commissions, appointees, agents, directors, employees, or independent contractors. In the event

that Grantor is required to indemnify Grantee pursuant to the terms of this paragraph, the amount of such indemnity, until discharged, shall constitute a lien on the Property with the same effect and priority as a mechanic's lien.

13. Written Notice: Any notice which either Grantor or Grantee may desire or be required to give to the other party shall be in writing;

Grantor: Historic Salem, Inc.
9 North Street
Salem, MA 01970

Grantee: Salem Historical Commission
c/o City of Salem
Department of Planning & Community Development
98 Washington Street
Salem, MA 01970

Each party may change its address set forth herein by a notice to such effect to the other party.

14. Evidence of Compliance: Upon request by Grantor, Grantee shall promptly furnish Grantor with certification that, to the best of Grantee's knowledge, Grantor is in compliance with the obligations of Grantor contained herein, or that otherwise evidence the status of this Restriction to the extent of Grantee's knowledge thereof.

15. Inspection: With the consent of Grantor, Grantee or its representatives shall be permitted at reasonable times to inspect the Building and the Property on an annual basis. Grantor covenants not to withhold unreasonably its consent in determining dates and times for such inspections.

16. Grantee's Remedies: The Grantor, for itself, its assigns and successors, expressly acknowledges that a violation of this Preservation Restriction Agreement, including a failure to expend such Funds for their intended purposes, may result in the Commission exercising its right to enforce the terms and conditions of the Restriction by seeking appropriate legal and equitable relief, including, but not limited to, restoration of the Building, repayment of the Funds, and such other legal and equitable remedies as may be available to the Commission to effectuate the purposes of this Restriction and to enforce the Grantor's obligations hereunder.

In the event Grantor is found to have violated any of its obligations, Grantor shall reimburse Grantee for any costs or expenses incurred in connection with Grantee's enforcement of the terms of this Restriction, including all court costs, and attorneys', architectural, engineering, and expert-witness fees. Grantor shall, at its own expense and with approval of Commission, reverse any actions or activities which violated this restriction and altered the Building.

Nothing in this Restriction shall impose upon the Commission any duty to maintain or require that the Building be maintained in any particular state or condition, notwithstanding the Commission's acceptance hereof. Enforcement of the terms of this Preservation Restriction shall be at the discretion of the Commission. Any election by the Commission as to the manner and timing of the exercising of its right to enforce this Preservation Restriction or otherwise exercise its rights hereunder shall not be deemed or construed to be a waiver of such rights. By its acceptance of this Preservation Restriction, the Commission does not assume any liability or obligation relating to the condition of the Building or the Property, including compliance with hazardous materials or other environmental laws and regulations.

17. Notice from Government Authorities: Grantor shall deliver to Grantee copies of any notice of violation or lien relating to the Building or Property received by Grantor from any government authority within five (5) days of receipt by Grantor. Upon request by Grantee, Grantor shall promptly furnish Grantee with evidence of Grantor's compliance with such notice or lien where compliance is required by law.

18. Notice of Proposed Sale: Grantor shall promptly notify Grantee in writing of any proposed sale of the Property and provide the opportunity for Grantee to explain the terms of the Restriction to potential new Grantors prior to sale closing.

19. Runs with the Land: Except as provided in Paragraphs 9 and 10, the restrictions, obligations and duties set forth in this Restriction shall run with the Property and shall inure to the benefit of the Commission and all parties claiming by, through or under the Commission and shall bind the Grantor and all parties claiming by, through or under the Grantor. The rights hereby granted to the Commission constitute the perpetual right of the Commission to enforce this Preservation Restriction Agreement. The Grantor hereby covenants for itself to stand seized and hold title to the Property subject to the terms of this Restriction. This Restriction shall extend to and be binding upon Grantor and Grantee, their respective successors in interest and all persons hereafter claiming under or through Grantor and Grantee, and the words "Grantor", "Grantee" when used herein shall include all such persons. Any right, title, or interest herein granted to Grantee also shall be deemed granted to each successor and assign of Grantee and each such following successor and assign thereof, and the word "Grantee" shall include all such successors and assigns.

Anything contained herein to the contrary notwithstanding, Grantor of the Property shall have no obligation pursuant to this instrument where such Grantor shall cease to have any Grantorship interest in the Property by reason of a bona fide transfer. The restrictions, stipulations and covenants contained in this Restriction shall be inserted by Grantor, verbatim or by express reference, in any subsequent deed or other legal instrument by which Grantor divests itself of either the fee simple title to or any lesser estate in the Property or any part thereof, including by way of example and not limitation, a lease of all or a portion of the Property.

20. Assignment: Grantee may convey, assign, or transfer this Restriction to a unit of federal, state, or local government or to a similar local, state, or national charitable corporation or trust that qualifies under the Act, and whose purposes, inter alia, are to the preservation of buildings or sites of historical significance, provided that any such conveyance, assignment or transfer requires that the Purpose for which the Restriction was granted will continue to be carried out. Grantor shall give prior written approval of such conveyance, assignment, or transfer by Grantee, such approval not to be unreasonably withheld.

21. Alternate Designee: Grantee may, at its discretion, remove and replace the Commission as its designee to administer, manage, and enforce this Restriction, provided that any new designee is qualified as such under the Act and other applicable law.

22. Recording and Effective Date: Grantee shall do and perform at its own cost all acts necessary to the prompt recording of this Restriction which shall become effective upon its being duly executed by the Grantor, the City of Salem, and the Salem Historical Commission, its being approved by the Massachusetts Historical Commission, and its being recorded with the Southern Essex District Registry of Deeds.

23. Extinguishment: Grantor and Grantee hereby recognize that an unexpected change in the conditions surrounding the Property may make impossible the continued Grantorship or use of the Property for the Purpose of this Restriction and necessitate extinguishment of the Restriction. Such a change in conditions may include, but is not limited to, partial or total destruction of the Building resulting from casualty. Such an extinguishment must meet all the requirements of the Act for extinguishment, including approvals following public hearings by the City of Salem and the Massachusetts Historical Commission to determine that such extinguishment is in the public interest. In the event of a sale of the Property, net proceeds of sale shall be paid to Grantor.

24. Condemnation: If all or any part of the Property is taken under the power of eminent domain by public, corporate, or other authority, or otherwise acquired by such authority through a purchase in lieu of a taking, Grantor and Grantee shall join in appropriate proceedings at the time of such taking to recover the full value of those interests in the Property that are subject to the taking and all incidental and direct

damages resulting from the taking. All expenses reasonably incurred by Grantor and Grantee in connection with such taking shall be paid out of the recovered proceeds. Such recovered proceeds shall be paid to Grantor.

25. Interpretation: The following provisions shall govern the effectiveness, interpretation, and duration of the Restriction:

- a. Any rule of strict construction designed to limit the breadth of restrictions on alienation or use of the Property shall not apply in the construction or interpretation of this Restriction and this instrument shall be interpreted broadly to affect its Purpose and the transfer of rights and the restrictions on use contained herein.
- b. This instrument may be executed in two counterparts, one of which is to be retained by Grantor and the other, after recording, to be retained by Grantee. In the event of any disparity between the counterparts produced, the recorded counterpart shall in all cases govern. Except as provided in the preceding sentence, each counterpart shall constitute the entire Restriction of the parties.
- c. This instrument is made pursuant to the Act, but the invalidity of such Act or any part thereof shall not affect the validity and enforceability of this Restriction according to its terms, it being the intent of the parties to agree and to bind themselves, their successors and their assigns in perpetuity to each term of this instrument whether this instrument be enforceable by reason of any statute, common law or private Restriction either in existence now or at any time subsequent hereto.
- d. Nothing contained herein shall be interpreted to authorize or permit Grantor to violate any ordinance or regulation relating to building materials, construction methods or use. In the event of any conflict between any such ordinance or regulation and the terms hereof Grantor promptly shall notify Grantee of such conflict and shall cooperate with Grantee and the applicable governmental entity to accommodate the purposes of both this Restriction and such ordinance or regulation.

If any court or other tribunal determines that any provision of this instrument is invalid or unenforceable, such provision shall be deemed to have been incorporated herein automatically to conform to the requirements for validity and enforceability as determined by such court or tribunal. In the event any provision invalidated is of such a nature that it cannot be modified, the provision shall be deemed deleted from this Preservation Restriction as though it had never been included herein. In either case, the remaining provisions of this instrument shall remain in full force and effect.

26. Amendment: If circumstances arise under which an amendment to or modification of this Restriction would be appropriate, Grantor and Grantee may by mutual written agreement jointly amend this Restriction, provided that no amendment shall be made that will adversely affect the qualification of this Restriction or the status of Grantee under any applicable law. Any such amendment shall be consistent with the protection of the preservation values of the Property and the Purpose of this Restriction; shall not affect its perpetual duration; shall not permit any private inurement to any person or entity; and shall not adversely impact the overall architectural and historic values protected by this Restriction. Any such amendment shall be effective when the requirements of the Act with respect to amendments have been met and the amendment is recorded in the Southern Essex District Registry of Deeds. Nothing in this paragraph shall require Grantor or Grantee to agree to any amendment or to consult or negotiate regarding any amendment.

27. Release: This Preservation Restriction is intended to be a restriction in gross in perpetuity and may only be released, in whole or in part, by the Grantee pursuant to the procedures for release established by the Act and otherwise by law, including approvals following public hearings by the City of Salem and the Massachusetts Historical Commission to determine that such a release is in the public interest.

28. Archaeological Activities: The conduct of archaeological activities on the Property, including ~~w~~without limitation survey, excavation, and artifact retrieval, may occur only following the submission of an archaeological field investigation plan prepared by the Grantor and approved in writing by the Grantee and the State Archaeologist of the Massachusetts Historical Commission (M.G.L. C. 9, Sec. 27C, 950 C.M.R. 70.00).

29. Subordination: Grantor and Grantee acknowledge that as of the date of this Agreement, the Property and the Building are subject to a perpetual Preservation Restriction Agreement held on the Property and the Building by the Commonwealth of Massachusetts by and through the Massachusetts Historical Commission and recorded with the Essex South Registry of Deeds on February 21, 2003 in Book 20199, Page 504 (hereinafter the "MHC Agreement"). Grantor agrees that in addition to complying with the restrictions contained in this Agreement, Grantor will continue to comply with the restrictions contained in the MHC Agreement. Grantor and Grantee agree that this Agreement shall be subservient to the MHC Agreement, and further agree that should any dispute arise between Grantee and the Massachusetts Historical Commission in the process of fulfilling the requirements of these restrictions, the Grantee shall defer to the demands and requirements set out by the Massachusetts Historical Commission.

IN WITNESS WHEREOF, the Grantor sets its hand and seal this 15 day of April, 2021.
By:

GRANTOR:
Historic Salem, Inc.

[Signature]
Caroline Watson-Felt
President

[Signature]
Gary Leach
Treasurer

COMMONWEALTH OF MASSACHUSETTS

Essex,ss.

On this 15th day of April, 2021, before me, the undersigned notary public, personally appeared Caroline Watson-Felt as President of Historic Salem, Inc., proved to me through satisfactory evidence of identification, which was (a current driver's license) (a current U.S. passport) (my personal knowledge of the identity of the principal), to be the person whose name is signed on the preceding or attached document, and acknowledged to me that s/he signed it voluntarily for its stated purposes as President of Historic Salem, Inc.

[Signature]
Notary Public
My Commission Expires: 1/29/2027

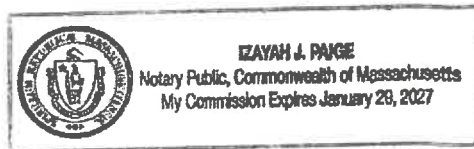

Essex,ss.

On this 15th day of April, 2021, before me, the undersigned notary public, personally appeared Gary Leach as Treasurer of Historic Salem, Inc., proved to me through satisfactory evidence of identification, which was (a current driver's license) (a current U.S. passport) (my personal knowledge of the identity of the principal), to be the person whose name is signed on the preceding or attached document, and acknowledged to me that s/he signed it voluntarily for its stated purposes as Treasurer of Historic Salem, Inc.

[Signature]
Notary Public
My Commission Expires: 1/29/2027

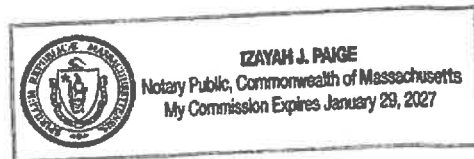

ACCEPTANCE BY THE SALEM HISTORICAL COMMISSION

Laurence Spang, duly authorized
Chair, Salem Historical Commission

COMMONWEALTH OF MASSACHUSETTS

Essex,ss.

On this ____ day of _____, 2021 before me, the undersigned notary public, personally appeared Lawrence Spang, proved to me through satisfactory evidence of identification, which was (a current driver's license) (a current U.S. passport) (my personal knowledge of the identity of the principal), to be the person whose name is signed on the preceding or attached document, and acknowledged to me that s/he signed it voluntarily for its stated purposes as duly authorized Chair of the Salem Historical Commission.

Notary Public
My Commission Expires:

ACCEPTANCE AND APPROVAL BY THE CITY OF SALEM

I, the undersigned City Clerk of the City of Salem, Massachusetts, hereby certify that at a meeting duly held on _____, 2021, the City Council voted to approve and accept the foregoing Preservation Restriction Agreement for the preservation of the historic resources of said City and being in the public interest pursuant to Massachusetts General Laws Chapter 184, Section 32.

By its Clerk

Ilene Simons
City Clerk

The undersigned hereby certifies that the foregoing preservation restrictions have been approved and accepted by the City of Salem

Kimberley Driscoll
Mayor

COMMONWEALTH OF MASSACHUSETTS

Essex, ss.

On this ____ day of _____, 2021, before me, the undersigned notary public, personally appeared Ilene Simons, proved to me through satisfactory evidence of identification, which was my personal knowledge of the identity of the principal, to be the person whose name is signed on the preceding or attached document, and acknowledged to me that s/he signed it voluntarily for its stated purposes as Clerk of the City of Salem.

Notary Public
My Commission Expires:

COMMONWEALTH OF MASSACHUSETTS

Essex, ss.

On this ____ day of _____, 2021, before me, the undersigned notary public, personally appeared, Kimberley Driscoll, proved to me through satisfactory evidence of identification, which was my personal knowledge of the identity of the principal, to be the person whose name is signed on the preceding or attached document, and acknowledged to me that she signed it voluntarily for its stated purposes as Mayor of the City of Salem.

Notary Public
My Commission Expires:

APPROVAL BY THE MASSACHUSETTS HISTORICAL COMMISSION

COMMONWEALTH OF MASSACHUSETTS

The undersigned Executive Director and Clerk of the Massachusetts Historical Commission hereby certifies that foregoing preservation restriction has been approved pursuant to Massachusetts General Laws, Chapter 184, Section 32.

MASSACHUSETTS HISTORICAL COMMISSION

Brona Simon
Executive Director and Clerk

COMMONWEALTH OF MASSACHUSETTS

Suffolk, ss.

On this ____ day of _____, 2021, before me, the undersigned notary public, personally appeared Brona Simon proved to me through satisfactory evidence of identification, which was (a current driver's license) (a current U.S. passport) (my personal knowledge of the identity of the principal), to be the person whose name is signed on the preceding or attached document, and acknowledged to me that she signed it voluntarily for its stated purposes.

Notary Public
My Commission Expires:

EXHIBIT A

Legal Property Description

The land with building and improvements thereon shown as Lot 2 (the "Premises") on a Plan entitled "Plan of Land in Salem, MA. Prepared for City of Salem" Scale 1" =10", dated December 23, 1998 by Hancock Survey Associates, Inc. (the "Plan") to be recorded herewith. Said Lot 2 contains 3,396 square feet more or less according to the Plan.

The Premises are a portion of the premises conveyed to the City of Salem by Historic Salem, Incorporated by Deed dated January 28, 1948, recorded with the Essex South Registry of Deeds, Book 3585, Page 340.

Source: Southern Essex District Registry of Deeds in Book 16412, Page 578.

EXHIBIT B

Recorded Plan

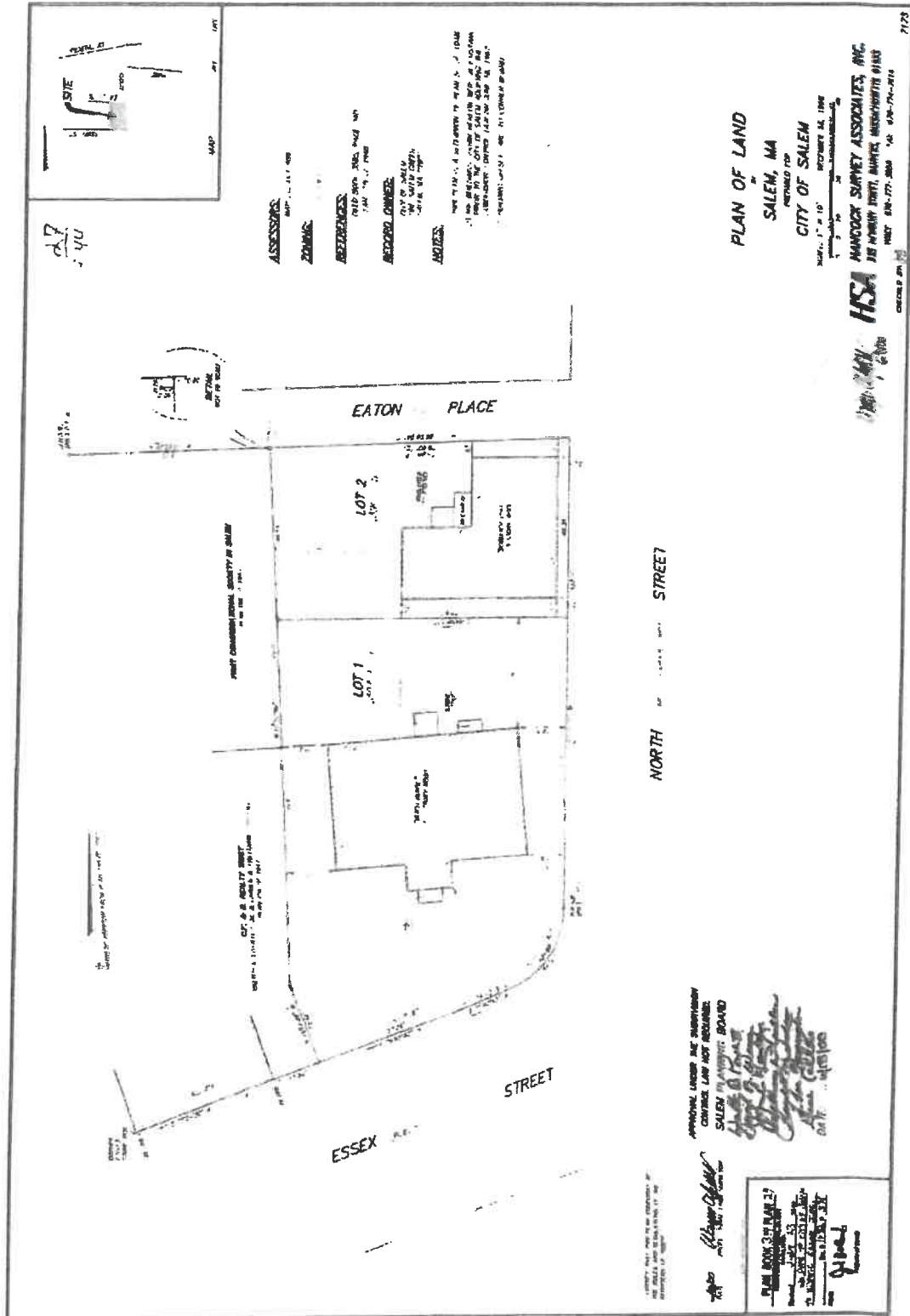

EXHIBIT C

Assessors' Parcel Map



EXHIBIT D

Baseline Photographs



Photo 1 – Main Façade (East Elevation)



Photo 2 – North Elevation



Photo 3 – Rear Addition, West elevation



Photo 4 – South Elevation



Photo 5 – Rear Addition, South elevation



Photo 6 – Door Detail Main Façade (East Elevation)

EXHIBIT E

RESTRICTION GUIDELINES

The purpose of the Restriction Guidelines is to clarify paragraphs 2 and 5 of the terms of the preservation restriction, which deals with alterations to the Property. Under this section permission from the SALEM HISTORICAL COMMISSION (COMMISSION) is required for any major alteration. Alterations of a minor nature, which are part of ordinary maintenance and repair, do not require COMMISSION review.

In an effort to explain what constitutes a minor alteration and what constitutes a major change, which must be reviewed by the COMMISSION, the following list has been developed. By no means is this list comprehensive: it is only a sampling of some of the more common alterations, which may be contemplated by the property owner.

PAINT

Minor - Exterior hand scraping and repainting of non-decorative and non-significant surfaces as part of periodic maintenance.

Major - Painting or fully stripping decorative surfaces or distinctive stylistic features including murals, stenciling, ornamental woodwork, stone, masonry, decorative or significant original stucco or plaster.

WINDOWS AND DOORS

Minor - Regular maintenance including caulking, painting and necessary reglazing. Repair or in-kind replacement of existing individual decayed window parts.

Major - Wholesale replacement of units; change in fenestration or materials; alteration of profile or setback of windows. The addition of storm windows is also considered a major change; however, with notification it is commonly acceptable.

EXTERIOR

Minor - Spot repair of existing cladding and roofing including in-kind replacement of clapboards, shingles, slates, etc.

Major - Large-scale repair or replacement of cladding or roofing. Change involving inappropriate removal or addition of materials or building elements (i.e. removal of chimneys or cornice detailing; installation of architectural detail which does not have a historical basis); altering or demolishing building additions; spot repointing of masonry. Structural stabilization of the property is also considered a major alteration.

LANDSCAPE/OUTBUILDINGS

Minor - Routine maintenance of outbuildings and landscape including lawn mowing, pruning, planting, painting, and repair.

Major - Moving or subdividing buildings or property; altering of property; altering or removing significant landscape features such as gardens, vistas, walks, plantings, walls, fences; ground disturbance affecting archaeological resources.

HEATING/AIR CONDITIONING/ELECTRICAL/PLUMBING SYSTEMS

Minor - Repair of existing systems.

Major - Installing or upgrading systems which will result in major exterior appearance changes (i.e. exterior ducts, piping, ventilators, HVAC units); the removal of substantial quantities of original materials in the course of construction.

Changes classified as major alterations are not necessarily unacceptable. Under the preservation restriction such changes must be reviewed by the COMMISSION and their impact on the historic integrity of the property assessed.

It is the responsibility of the property owner to notify the COMMISSION in writing when any major alterations are contemplated. Substantial alterations may necessitate review of plans and specifications.

The intent of the preservation restriction is to enable the COMMISSION to review proposed alterations and assess their impact on the integrity of the building, not to preclude future change. COMMISSION will attempt to work with property owner to develop mutually satisfactory solutions, which are in the best interests of the Property.

ACCEPTANCE AND APPROVAL BY THE CITY OF SALEM

I, the undersigned City Clerk of the City of Salem, Massachusetts, hereby certify that at a meeting duly held on _____, 2021, the City Council voted to approve and accept the foregoing Preservation Restriction Agreement for the preservation of the historic resources of said City and being in the public interest pursuant to Massachusetts General Laws Chapter 184, Section 32.

By its Clerk

Ilene Simons
City Clerk

The undersigned hereby certifies that the foregoing preservation restrictions have been approved and accepted by the City of Salem

Kimberley Driscoll
Mayor

COMMONWEALTH OF MASSACHUSETTS

Essex, ss.

On this ____ day of _____, 2021, before me, the undersigned notary public, personally appeared Ilene Simons, proved to me through satisfactory evidence of identification, which was my personal knowledge of the identity of the principal, to be the person whose name is signed on the preceding or attached document, and acknowledged to me that s/he signed it voluntarily for its stated purposes as Clerk of the City of Salem.

Notary Public
My Commission Expires:

COMMONWEALTH OF MASSACHUSETTS

Essex, ss.

On this ____ day of _____, 2021, before me, the undersigned notary public, personally appeared, Kimberley Driscoll, proved to me through satisfactory evidence of identification, which was my personal knowledge of the identity of the principal, to be the person whose name is signed on the preceding or attached document, and acknowledged to me that she signed it voluntarily for its stated purposes as Mayor of the City of Salem.

Notary Public
My Commission Expires:

Ilene Simons

From: Jane Guy
Sent: Monday, June 14, 2021 10:09 AM
To: Ilene Simons
Subject: Bowditch House Preservation Restriction
Attachments: HSI PR with HSI sigpage.pdf; Council Mayor Sig Page.pdf

Hi Ilene,

Attached is the Preservation Restriction for the Bowditch House which is being granted as a condition of CPA funding. The document has been reviewed by Massachusetts Historical Commission, signed by the Historic Salem, Inc. officers, and accepted by the Salem Historical Commission.

It now needs acceptance by the City Council and Mayor. Will you please put this before the Council at your earliest opportunity? I have separated out the signature page for you to date and sign. I will pick it up when it is ready.

Thank you!

-Jane

Jane A. Guy
Assistant Community Development Director
City of Salem
Department of Planning & Community Development
98 Washington St., 2nd Floor
Salem, MA 01970
978-619-5685

We no longer have a fax number.

jguy@salem.com

www.salem.com

Questions contact – Sibhita Mahabier 781-258-9169

Petition of the Massachusetts Electric Company d/b/a National Grid
Of NORTH ANDOVER, MASSACHUSETTS
For Electric conduit Location:

To City Council of Salem, Massachusetts

Respectfully represents the Massachusetts Electric Company d/b/a National Grid of North Andover, Massachusetts, that it desires to construct a line of underground electric conduits, including the necessary sustaining and protecting fixtures, under and across the public way or ways hereinafter named.

Wherefore it prays that after due notice and hearing as provided by law, it be granted permission to excavate the public highways and to run and maintain underground electric conduits, together with such sustaining and protecting fixtures as it may find necessary for the transmission of electricity, said underground conduits to be located substantially in accordance with the plan filed herewith marked: First St - Salem - Massachusetts.

The following are the streets and highways referred to:

Plan # 30334561 First St - National Grid to install beginning at a point approximately 25 feet south/southwest of the centerline of the intersection of Whalers Ln and First St and continuing approximately 350 feet in a north/northeast direction. Installation of 350' +/- of 4-5" PVC conduits from MH 2 to MH 1 on First St.

Location approximately as shown on plan attached

Massachusetts Electric Company d/b/a National Grid
BY Robert Coulter
Engineering Department

Dated: May 28, 2021

ORDERED:

Notice having been given and public hearing held, as provided by law, that the Massachusetts Electric Company d/b/a National Grid be and it is hereby granted permission to excavate the public highways and to run and maintain underground electric conduits, together with such sustaining and protecting fixtures as said company may deem necessary, in the public way or ways hereinafter referred to, and to make the necessary house connections along said extensions, as requested in petition with said company dated the 28th day of May, 2021.

Said underground electric conduits shall be located substantially in accordance with the plan filed herewith marked – First St - Salem - Massachusetts. Plan # 30334561.

The following are the public ways or part of ways along which the underground electric conduits above referred to may be laid:

First St - National Grid to install beginning at a point approximately 25 feet south/southwest of the centerline of the intersection of Whalers Ln and First St and continuing approximately 350 feet in a north/northeast direction. Installation of 350' +/- of 4-5" PVC conduits from MH 2 to MH 1 on First St.

I hereby certify that the foregoing order was adopted at a meeting of the
....., held on the day of, 20
.....,, 20

Received and entered in the records of location orders of the City/Town of
Book Page

Attest:
.....

..... hereby certify that on20....., at o'clock,M
at, a public hearing was held on the petition of
Massachusetts Electric Company d/b/a National Grid for permission to construct the underground
electric conduits described in the order herewith recorded, and that I mailed at least seven days
before said hearing a written notice of the time and place of said hearing to each of the owners of
real estate (as determined by the last preceding assessment for taxation) along the ways or parts of
ways upon which the Company is permitted to construct the underground electric conduits under
said order. And that thereupon said order was duly adopted.

.....
.....

ORDERED:

Notice having been given and public hearing held, as provided by law, that the Massachusetts Electric Company d/b/a National Grid be and it is hereby granted permission to excavate the public highways and to run and maintain underground electric conduits, together with such sustaining and protecting fixtures as said company may deem necessary, in the public way or ways hereinafter referred to, and to make the necessary house connections along said extensions, as requested in petition with said company dated the 28th day of May, 2021.

Said underground electric conduits shall be located substantially in accordance with the plan filed herewith marked – First St - Salem - Massachusetts. Plan # 30334561.

The following are the public ways or part of ways along which the underground electric conduits above referred to may be laid:

First St - National Grid to install beginning at a point approximately 25 feet south/southwest of the centerline of the intersection of Whalers Ln and First St and continuing approximately 350 feet in a north/northeast direction. Installation of 350' +/- of 4-5" PVC conduits from MH 2 to MH 1 on First St.

I hereby certify that the foregoing order was adopted at a meeting of the
.....
....., held on the day of, 20
....., 20

Received and entered in the records of location orders of the City/Town of
Book Page

Attest:
.....

..... hereby certify that on20....., at o'clock,M
at, a public hearing was held on the petition of
Massachusetts Electric Company d/b/a National Grid for permission to construct the underground
electric conduits described in the order herewith recorded, and that I mailed at least seven days
before said hearing a written notice of the time and place of said hearing to each of the owners of
real estate (as determined by the last preceding assessment for taxation) along the ways or parts of
ways upon which the Company is permitted to construct the underground electric conduits under
said order. And that thereupon said order was duly adopted.

.....
.....

Parcel ID	Address	Owner	Mailing Address
08-0163-0	50 Traders Way Salem, MA 01970	HD Salem-GP LLC/Home Depot	P.O. Box 105842 Atlanta, GA 30348-5842
13-0011-0	40 First Street Salem, MA 01970	Traders Way Residential Holding LLC	150 Presidential Way St. Woburn, MA 01801
13-0008-0	43 First Street Salem, MA 01970	Salem Conservation Comm	93 Washington St Salem, MA 01970
07-0089-851	8 Whalers Lane Salem, MA 01970	Kellett, J Peter	8 Whalers Lane U95C Salem, MA 01970

NORTH

TRADERS WAY

FIRST STREET

MH 1

Proposed 350' +/- of 4-5" PVC Conduits

Existing 4-5" PVC CONDUITS

MH 2

WHALERS LANE

UNDERGROUND PETITION

nationalgrid

○ MANHOLE (EXISTING)

— EXISTING CONDUIT 4-5"

- - - PROPOSED CONDUIT 4-5"

Installation of missing 4-5" PVC Conduits encased in Concrete from MH 2 to MH 1 in First St., Salem, MA 01970

WR# 12-21-30334561

Date: 04-02-2021

WORK REQUEST: 12-21-30334561

To The: City Of Salem

For Proposed: 4-5" PVC Conduits Location: First Street

Drawn By: Sibhita Mahabier-Sheehy

DISTANCES ARE APPROXIMATE

Questions contact – Elizabeth Cardarelli 781-258-9169

PETITION FOR JOINT OR IDENTICAL POLE LOCATIONS

North Andover, Massachusetts

To the City Council
Of Salem, Massachusetts

Massachusetts Electric Company d/b/a National Grid and Verizon New England, Inc requests permission to locate poles, wires, and fixtures, including the necessary sustaining and protecting fixtures, along and across the following public way:

Forrester St- National Grid to relocate 1 JO Pole on Forrester St beginning at a point approximately 400 feet NNE of the centerline of the intersection of Washington Square East and continuing approximately 15 feet in a SSW direction. Relocate P3826, 15 ft from existing location on Forrester St.

Location approximately as shown on plan attached

Wherefore it prays that after due notice and hearing as provided by law, it be granted a location for and permission to erect and maintain poles and wires, together with such sustaining and protecting fixtures as it may find necessary, said poles to be erected substantially in accordance with the plan filed herewith marked – Forrester St - Salem – Massachusetts.

No.# 30380771 June 7, 2021

Also for permission to lay and maintain underground laterals, cables, and wires in the above or intersecting public ways for the purpose of making connections with such poles and buildings as each of said petitioners may desire for distributing purposes.

Your petitioner agrees to reserve space for one cross-arm at a suitable point on each of said poles for the fire, police, telephone, and telegraph signal wires belonging to the municipality and used by it exclusively for municipal purposes.

Massachusetts Electric Company d/b/a National Grid
BY Robert Coulter
Engineering Department

VERIZON NEW ENGLAND, INC.

BY _____
Manager / Right of Way

Salem

ORDER FOR JOINT OR IDENTICAL POLE LOCATIONS

To the City Council - Salem, Massachusetts

Notice having been given and public hearing held, as provided by law,
IT IS HEREBY ORDERED:

that Massachusetts Electric Company d/b/a National Grid and VERIZON NEW ENGLAND INC. (formerly known as NEW ENGLAND TELEPHONE AND TELEGRAPH COMPANY) be and they are hereby granted joint or identical locations for and permission to erect and maintain poles and wires to be placed thereon, together with such sustaining and protecting fixtures as said Companies may deem necessary, in the public way or ways hereinafter referred to, as requested in petition of said Companies dated the 7th day of June, 2021.

All construction under this order shall be in accordance with the following conditions:

Poles shall be of sound timber, and reasonable straight, and shall be set substantially at the points indicated upon the plan marked – Forrester St - Salem – Massachusetts. WR # 30380771.

June 7, 2021. Filed with this order

There may be attached to said poles by Massachusetts Electric Company d/b/a National Grid and Verizon New England Inc. such wires, cables, and fixtures as needed in their business and all of said wires and cables shall be placed at a height of not less than twenty (20) feet from the ground.

The following are the public ways or part of ways along which the poles above referred to may be erected, and the number of poles which may be erected thereon under this order:

Forrester St- National Grid to relocate 1 JO Pole on Forrester St beginning at a point approximately 400 feet NNE of the centerline of the intersection of Washington Square East and continuing approximately 15 feet in a SSW direction. Relocate P3826, 15 ft from existing location on Forrester St.

Also for permission to lay and maintain underground laterals, cables, and wires in the above or intersecting public ways for the purpose of making connections with such poles and buildings as each of said petitioners may desire for distributing purposes.

I hereby certify that the foregoing order was adopted at a meeting of the
of the City/Town of _____, Massachusetts held on the _____ day of _____ 20__.

Massachusetts City/Town Clerk. 20__

Received and entered in the records of location orders of the City/Town of
Book _____ Page _____

Attest:
City/Town Clerk

I hereby certify that on _____, 20____, at _____ o'clock, M
at _____ a public hearing was held on the petition of
Massachusetts Electric Company d/b/a National Grid and VERIZON NEW ENGLAND, INC.

for permission to erect the poles, wires, and fixtures described in the order herewith recorded, and
that we mailed at least seven days before said hearing a written notice of the time and place of said
hearing to each of the owners of real estate (as determined by the last preceding assessment for
taxation) along the ways or parts of ways upon which the Company is permitted to erect
poles, wires, and fixtures under said order. And that thereupon said order was duly adopted.

City/Town Clerk.

.....
.....
.....
.....

Board or Council of Town or City, Massachusetts

CERTIFICATE

I hereby certify that the foregoing is a true copy of the location order and certificate of
hearing with notice adopted by the _____ of the City of
Massachusetts, on the _____ day of _____, 20____, and recorded with the
records of location orders of the said City, Book _____, Page _____. This certified copy
is made under the provisions of Chapter 166 of General Laws and any additions thereto or
amendments thereof.

Attest:
City/Town Clerk

NGRID

ORDER FOR JOINT OR IDENTICAL POLE LOCATIONS

To the City Council - Salem, Massachusetts

Notice having been given and public hearing held, as provided by law,
IT IS HEREBY ORDERED:

that Massachusetts Electric Company d/b/a National Grid and VERIZON NEW ENGLAND INC. (formerly known as NEW ENGLAND TELEPHONE AND TELEGRAPH COMPANY) be and they are hereby granted joint or identical locations for and permission to erect and maintain poles and wires to be placed thereon, together with such sustaining and protecting fixtures as said Companies may deem necessary, in the public way or ways hereinafter referred to, as requested in petition of said Companies dated the 7th day of June, 2021.

All construction under this order shall be in accordance with the following conditions:

Poles shall be of sound timber, and reasonable straight, and shall be set substantially at the points indicated upon the plan marked - Forrester St - Salem - Massachusetts. WR # 30380771.

June 7, 2021. Filed with this order

There may be attached to said poles by Massachusetts Electric Company d/b/a National Grid and Verizon New England Inc. such wires, cables, and fixtures as needed in their business and all of said wires and cables shall be placed at a height of not less than twenty (20) feet from the ground.

The following are the public ways or part of ways along which the poles above referred to may be erected, and the number of poles which may be erected thereon under this order:

Forrester St- National Grid to relocate 1 JO Pole on Forrester St beginning at a point approximately 400 feet NNE of the centerline of the intersection of Washington Square East and continuing approximately 15 feet in a SSW direction. Relocate P3826, 15 ft from existing location on Forrester St.

Also for permission to lay and maintain underground laterals, cables, and wires in the above or intersecting public ways for the purpose of making connections with such poles and buildings as each of said petitioners may desire for distributing purposes.

I hereby certify that the foregoing order was adopted at a meeting of the
of the City/Town of _____, Massachusetts held on the _____ day of _____ 20__ .

Massachusetts City/Town Clerk.
20__ .

Received and entered in the records of location orders of the City/Town of
Book _____ Page _____

Attest:
City/Town Clerk

I hereby certify that on _____, 20____, at _____ o'clock, M
at _____ a public hearing was held on the petition of
Massachusetts Electric Company d/b/a National Grid and VERIZON NEW ENGLAND, INC.

for permission to erect the poles, wires, and fixtures described in the order herewith recorded, and
that we mailed at least seven days before said hearing a written notice of the time and place of said
hearing to each of the owners of real estate (as determined by the last preceding assessment for
taxation) along the ways or parts of ways upon which the Company is permitted to erect
poles, wires, and fixtures under said order. And that thereupon said order was duly adopted.

City/Town Clerk.

.....
.....
.....
.....

Board or Council of Town or City, Massachusetts

CERTIFICATE

I hereby certify that the foregoing is a true copy of the location order and certificate of
hearing with notice adopted by the _____ of the City of
Massachusetts, on the _____ day of _____, 20____, and recorded with the
records of location orders of the said City, Book _____, Page _____. This certified copy
is made under the provisions of Chapter 166 of General Laws and any additions thereto or
amendments thereof.

Attest:
City/Town Clerk

Address	Owner	Mailing Address
11 Forrester St., Salem, MA 01970	Benjamin A. Carlson	2 Leather Lane Beverly, MA 1915
12 Forrester St., Salem, MA 01970	Ann Czarnecki Edward Czarnecki	12 Forrester St., Salem, MA 01970
14 Forrester St., Salem, MA 01970	Jennifer M. Evans Mark Cathrall	14 Forrester St., Unit# 1, Salem, MA 01970
14 Forester St., Salem, MA 01970	Joanna Duby Paul D. Michaels	14 Forrester St., Unit# 2, Salem, MA 01970
15 Forrester St., Salem, MA 01970	Janice Costa C/O Mike Costa	57 Bradlee Ave., Swampscott, MA 01907
16 Forrester St., Salem, MA 01970	Den Jin Set Gen Yu Set	18 Forrester St., Salem, MA 01970
21 Forrester St., Salem, MA 01970	Edward E. Keenan III Dorothy E. Keenan	21 Forrester St., Salem, MA 01970
22 Forrester St., Salem, MA 01970	Sean Lunde Leah Worbs Lunde	22 Forrester St., Salem, MA 01970

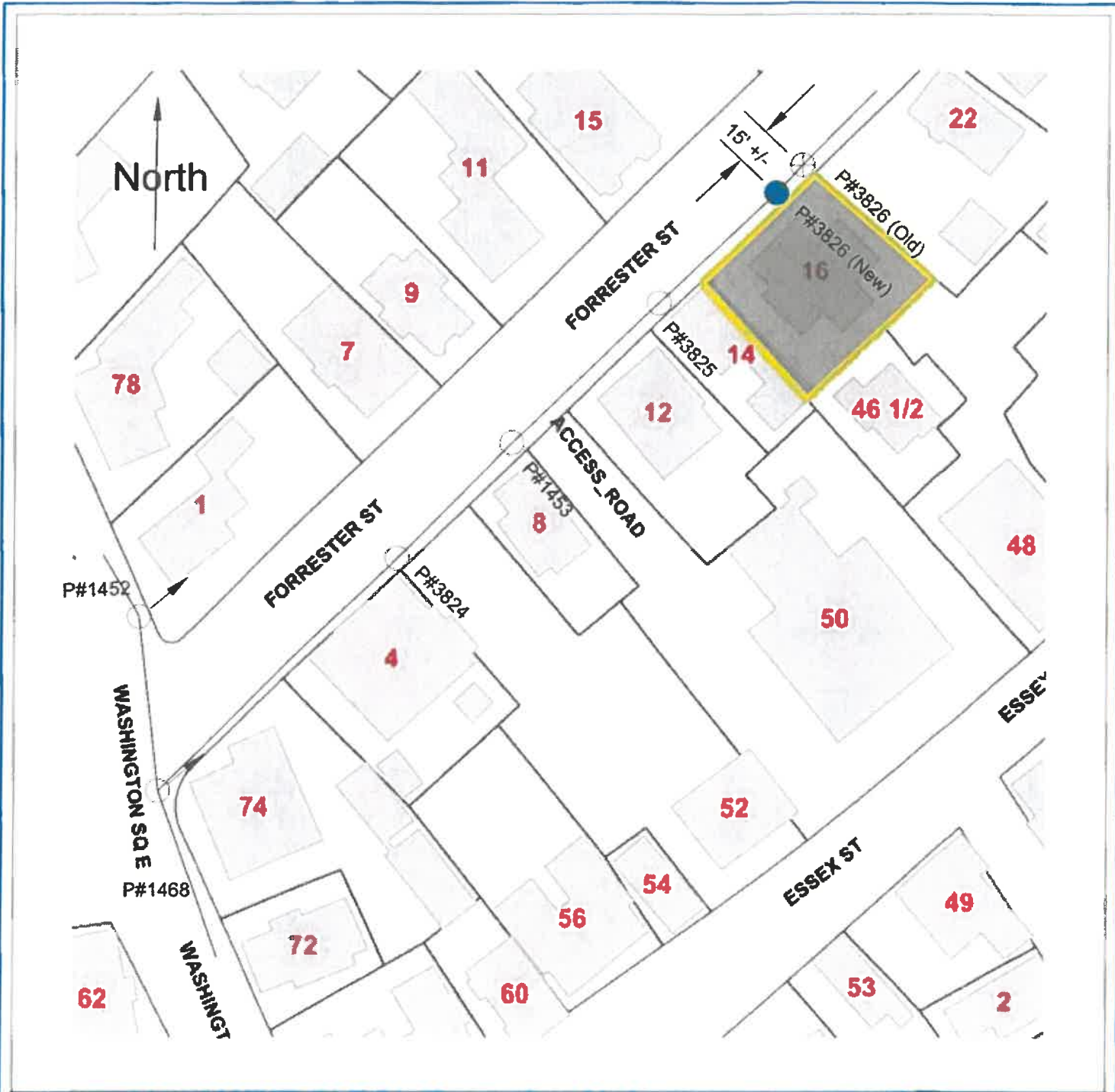

JOINT OWNED POLE PETITION

- Proposed JO Pole Locations
- Existing JO Pole Locations
- ⊕ Existing J.O. Pole to be Removed
- ⊙ Existing NGRID Pole Location To Be Made J.O.
- ← Existing Anchor and Guy

DISTANCES ARE APPROXIMATE

nationalgrid
And
Verizon New England, Inc.

Date: 6-4-2021

Work Request Number: 12-21-30380771

To Accompany Petition Dated: 06-04-2021

To The: City Of Salem, MA

For Proposed: **Relocation** of Pole: #3826 Location: Forrester St

Dear Madame Clerk Ilene Simons and City Council Members:

We, the undersigned registered voters, pursuant to MGL Chapter 40A section 5 request that the following Zoning ordinance be submitted within 14 days to the Planning Board for review and recommendation back to the Council.

Temporary Moratorium

No new building permits shall be issued for any construction within the buffer zones of a wetland or on a floodplain in any zoning district within the City of Salem for a period of 2 years. The reason for this temporary moratorium is because the City has experienced multiple projects being approved for construction within the buffer zones of wetlands and within floodplains. Time is needed so that the city can conduct a comprehensive study on the impact of construction within buffer zones and floodplains. This moratorium shall not apply to building permits for future phases of any project which has obtained all required permits and approvals. This moratorium shall apply to building permits that would encroach upon our wetlands and floodplains from the date of this ordinance.

Name	Address	Signature	
✓ 1	6 LOWELL ST SALEM, MA	Ward 1	WARD 1 1
✓ 2	6 Lowell St Salem		
✓ 3	4 Lowell St Salem		
✓ 4	74 Moffett Rd		7 1
✓ 5	25 HIGH ST SALEM		2 2
✓ 6	4 Harrison Rd Salem		7 7
✓ 7	18 Raymond Rd		7 1
✓ 8	74 Moffett Rd		7 1
✓ 9	20 1/2 Barnes Rd. At		9 9
✓ 10	20 1/2 Barnes Rd		3 3
✓ 11	23A WISTERIA ST		5 1
✓ 12	23 Wulera St		5 1
✓ 13	23A WISTERIA ST		5 1
14			
15			

Dear Madame Clerk Ilene Simons and City Council Members:

We, the undersigned registered voters, pursuant to MGL Chapter 40A section 5 request that the following Zoning ordinance be submitted within 14 days to the Planning Board for review and recommendation back to the Council.

Temporary Moratorium

No new building permits shall be issued for any construction within the buffer zones of a wetland or on a floodplain in any zoning district within the City of Salem for a period of 2 years. The reason for this temporary moratorium is because the City has experienced multiple projects being approved for construction within the buffer zones of wetlands and within floodplains. Time is needed so that the city can conduct a comprehensive study on the impact of construction within buffer zones and floodplains. This moratorium shall not apply to building permits for future phases of any project which has obtained all required permits and approvals. This moratorium shall apply to building permits that would encroach upon our wetlands and floodplains from the date of this ordinance.

Name	Address	Signature	Word	
✓ 1 Benjamin Arlander	10 Norman St #404	Benjamin Arlander	2	2
✓ 2 Paul Labrie	11 Hemenway	Paul Labrie	5	1
✓ 3 David Freni	5 Wyman Dr.	David Freni	3	
✓ 4 Robert Camire	10 Francis Rd	Robert Camire	3	
✓ 5 Stella Oneil	6 Foster St	Stella Oneil	6	
6				
7				
8				
9				
10				
11				
12				
13				
14				
15				

Dear Madame Clerk Ilene Simons and City Council Members:

We, the undersigned registered voters, pursuant to MGL Chapter 40A section 5 request that the following Zoning ordinance be submitted within 14 days to the Planning Board for review and recommendation back to the Council.

Temporary Moratorium

No new building permits shall be issued for any construction within the buffer zones of a wetland or on a floodplain in any zoning district within the City of Salem for a period of 2 years. The reason for this temporary moratorium is because the City has experienced multiple projects being approved for construction within the buffer zones of wetlands and within floodplains. Time is needed so that the city can conduct a comprehensive study on the impact of construction within buffer zones and floodplains. This moratorium shall not apply to building permits for future phases of any project which has obtained all required permits and approvals. This moratorium shall apply to building permits that would encroach upon our wetlands and floodplains from the date of this ordinance.

Name	Address	Signature	Ward	Pct
✓ 1 MaryAnne Silva	17 Summer Rd		7-2	
✓ 2 F. A. Silva	17 Summer Rd		7	2
✓ 3 Sandra E. Antunes	6 Derby St.		1	
✓ 4 Mike Myslinski	26 Grove St			
✓ 5 Joan Manton	24 Leavitt St		5	1
✓ 6 Robert E. Buckley	38 Hanson Street			
7				
8				
9				
10				
11				
12				
13				
14				
15				



CITY OF SALEM, MASSACHUSETTS
PARK, RECREATION & COMMUNITY SERVICE

401 Bridge Street, Salem MA 01970
Tel. (978) 744-0180/(978) 744-0924
pobrien@salem.com

Kimberley Driscoll
MAYOR

Trish O'Brien
Superintendent

Road Bike/Race/Walk/Parade Application

**PLEASE SUBMIT PAYMENT OF \$200 WITH THIS PERMIT APPLICATION TO THE CITY OF SALEM
PARK, RECREATION AND COMMUNITY SERVICES DEPARTMENT NO LATER THAN 45 DAYS
PRIOR TO THE EVENT.
Registered Non-Profit Fee \$150
ANY FOR PROFIT EVENTS WILL REQUIRE AN ADDITIONAL 5% FROM THE
REGISTRATION FEES POST EVENT.**

We, the undersigned, respectfully apply for permission to host a road race/walk in the City of Salem as follows:

Applicant's Name: Ashley Steeves

Organization Name: B+S Fitness

Name of Race/Walk/Parade: Devils Chace 6.66 + Cnepy Clawn 3.33 Road Race

Contact #: 978 594 7050 E-Mail Address event@bnsfitness.com

Address: 10 Hemenway Rd.

City/State/Zip: Salem MA 01970

Organization Tax Status (please include Tax ID Number): NA

What Charities Will This Race/Walk Be Benefiting?
Salem Childrens Charity + Leap Education Inc.

Approximately How Much of the Race/Walk/Parade Proceeds Will Be Donated to Each Charity(s)
a minimum of \$1000

Day of Race/Walk Contact Information:

Name: Ashley Steeves Contact #: 978 594 7050

Date of Event: 10/23/21 Estimated Number of Participants: 1000

Time of Event: 8:00AM Estimated Finish Time of Event: 10:30AM / 11:00AM

Start Location: Salem Willows Soccer Field Finish Location: Salem Willows Soccer Field

Distance of Event: 6.66 + 3.33 miles

Has This Event Been Held Before? Yes No

All Races/Walks/Parades Are Required to Recycle and Remove Trash.

Please Explain Your Plan (Will You Bring to North Shore Recycled Fiber on 53 Jefferson Ave, Open M-F; Bring to Your Home Curbside, or Other?) If You Have Questions about Recycling, Please Contact Julie Rose for More Information 978-619-5679

AS will remove all trash recycling

Onsite EMT/Ambulance Service (Required): AS initial

Please Attach a Map of Route With the Following Items:

1. Race/Walk Course
2. Direction of Runners Through the Race/Walk course
3. Starting and Finishing Points
4. Meeting Points For Racers Before and After the Race/Walk
5. Last year's race financials

Certificate of Insurance Attached? Yes No

A certificate of insurance for general liability naming the City of Salem as primary additional insured for amount not less than \$1,000,000 combined single limit for injury or death or property damages (including loss of use) in any one occurrence, and \$1,000,000 general aggregate coverage. (The City of Salem reserves the right to increase coverage minimum if event presents extraordinary risk).

RELEASE & INDEMNITY AGREEMENT APPLICANT'S SIGNATURE The undersigned Sponsor, by signature below, shall defend, indemnify, and hold the City of Salem, its officers, agents and employees, harmless against all liability, loss, or expenses, including attorney's fees, and against all claims, actions or judgments based upon or arising out of damage or injury (including death) to persons or property caused by any act or omission of an act sustained in any way in connections with the performance of this event or by conditions created thereby, or based upon violation of any statute, ordinance or regulation. This contractual indemnity provision does not abrogate common law or statutory liability and indemnification to the City of Salem, but is in addition to such common law or statutory provisions.

Ashley Steves Date: 2/4/21
Applicant's signature

Ashley Steves
Name of applicant

A copy of this permit will be sent to the applicant upon approval. Please call Park, Recreation & Community Services if you have any questions. 978-744-0924

CITY USE ONLY

Payment Received: _____ Date Permit Issued: _____ Date Permit Mailed to Applicant: _____

Approved By:

[Signature] OR 5-17-21
Director (Or Designee) of Salem Park, Recreation & Community Services

Capt. Mark [Signature] 5-17-21 * Tentative approval provided a plan submitted and approved by Health Dept.
Salem Police Department

Effective date of form: 2/8/12
Revised date of form: 1/1/18

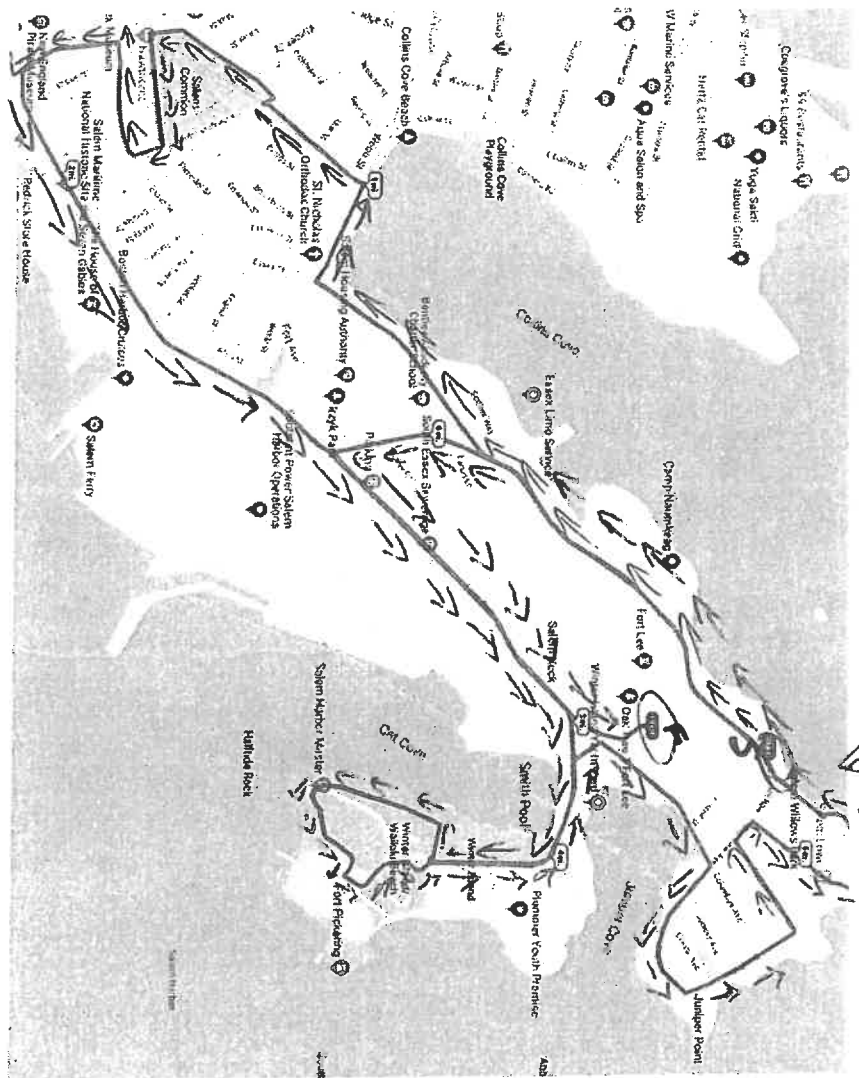

** Runners go by street to camp like
 on the loop around memorial dr*

6.66 Turn by Turn

- Start on Restaurant Row by Tennis Courts
- Straight down Memorial Dr
- Straight on Stetela Ln
- Right on Walking Path before Webb St
- Left on Andrew St
- Enter the Salem Common on Washington Sq E
- Run counter clockwise around the Salem Common
- Exit the Common at S Washington Sq on to Forester St
- Right on to Essex St
- Left on to Little Hawthorne Blvd
- Left on to Derby St
- Straight Down Derby St
- Bele right on Winter Island Rd.
- Follow cross country trail around Winter Island, by Harbormaster, behind the function hall, by Dave's office, left heading back out of parking lot, and keep right of check in house to exit WI.
- Right on Columbus Sq.
- Proceed down Columbus Ave
- Right on Bay View Ave
- Left on Beach Ave
- Left on Sutton Ave
- Right on to Bay View Ave
- Right on Willows Access Road
- Follow walking path around the backside of the Willows by the yacht club
- Exit back on to Restaurant Row
- Follow straight up Memorial Dr
- Bare right at Stetela Ln, to stay on Memorial Dr
- Left on to Fort Ave
- Left on to Memorial Drive by Soccer field to FINISH

2019 approved course

*1 way out
 1 way back*

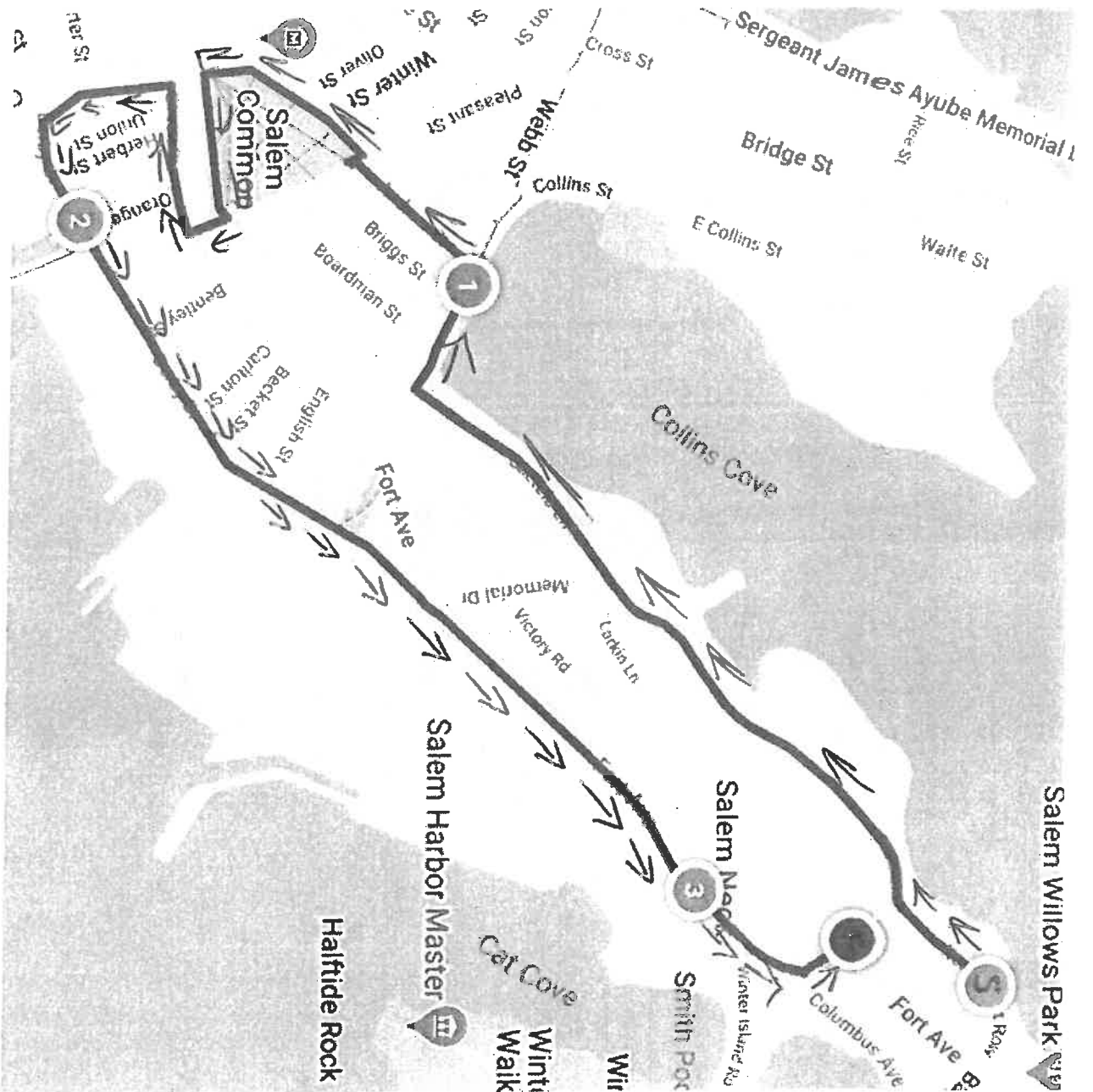

Creepy Clown
Turn by Turn 3.33

- Start on Fort Ave at Memorial Dr.
- Straight down Memorial Dr
- Straight on Szetela Ln
- Right on Walking Path before Webb St
- Left on Andrew St
- Enter the Salem Common on Washington Sq E
- Run counter clockwise around the Salem Common
- Exit the Common at S Washington Sq on to Forester St
- Right on to Essex St
- Left on to Little Hawthorne Blvd
- Left on to Derby St
- Straight Down Derby St
- Continue down Fort Ave
- Left on to Memorial Dr by Soccer Field to FINISH

*away at
 away back
 2019 ground carne*



CERTIFICATE OF LIABILITY INSURANCE

DATE(MM/DD/YYYY)
02/05/21

THIS CERTIFICATE IS ISSUED AS A MATTER OF INFORMATION ONLY AND CONFERS NO RIGHTS UPON THE CERTIFICATE HOLDER. THIS CERTIFICATE DOES NOT AFFIRMATIVELY OR NEGATIVELY AMEND, EXTEND OR ALTER THE COVERAGE AFFORDED BY THE POLICIES BELOW. THIS CERTIFICATE OF INSURANCE DOES NOT CONSTITUTE A CONTRACT BETWEEN THE ISSUING INSURER(S), AUTHORIZED REPRESENTATIVE OR PRODUCER, AND THE CERTIFICATE HOLDER.

IMPORTANT: If the certificate holder is an ADDITIONAL INSURED, the policy(ies) must be endorsed. If SUBROGATION IS WAIVED, subject to the terms and conditions of the policy, certain policies may require an endorsement. A statement on this certificate does not confer rights to the certificate holder in lieu of such endorsement(s).

PRODUCER CURTIS J. VERNON INSURANCE AGENCY PO BOX 266 BOUNTIFUL, UT 84010	CONTACT NAME:		
	PHONE (A/C No. Ext):	(801) 292-5529	FAX (A/C No.): (801) 677-0077
	E-MAIL ADDRESS:		
	INSURER(S) AFFORDING COVERAGE		NAIC#
	INSURER A:	UNDERWRITERS AT LLOYD'S, LONDON	32727
	INSURER B:		
	INSURER C:		
	INSURER D:		
	INSURER E:		
	INSURER F:		

INSURED **B&S FITNESS PROGRAMS LLC**
45 CONGRESS STREET, DOCK 19-20
SALEM, MA 01970

COVERAGES CERTIFICATE NUMBER: REVISION NUMBER:
THIS IS TO CERTIFY THAT THE POLICIES OF INSURANCE LISTED BELOW HAVE BEEN ISSUED TO THE INSURED NAMED ABOVE FOR THE POLICY PERIOD INDICATED. NOTWITHSTANDING ANY REQUIREMENT, TERM OR CONDITION OF ANY CONTRACT OR OTHER DOCUMENT WITH RESPECT TO WHICH THIS CERTIFICATE MAY BE ISSUED OR MAY PERTAIN, THE INSURANCE AFFORDED BY THE POLICIES DESCRIBED HEREIN IS SUBJECT TO ALL THE TERMS, EXCLUSIONS AND CONDITIONS OF SUCH POLICIES. LIMITS SHOWN MAY HAVE BEEN REDUCED BY PAID CLAIMS.

INSR LTR	TYPE OF INSURANCE	ADDL INSD	SUBR WVD	POLICY NUMBER	POLICY EFF (MM/DD/YYYY)	POLICY EXP (MM/DD/YYYY)	LIMITS				
X	COMMERCIAL GENERAL LIABILITY CLAIMS-MADE <input checked="" type="checkbox"/> OCCUR			MSJ0427789128	02/01/21	02/01/22	EACH OCCURRENCE \$ 1,000,000				
A	GEN'L AGGREGATE LIMIT APPLIES PER: <input checked="" type="checkbox"/> POLICY <input type="checkbox"/> PRO-JECT <input type="checkbox"/> LOC OTHER:	Y					DAMAGE TO RENTED PREMISES (Ea occurrence) \$ 100,000	MED EXP (Any one person) \$ 5,000	PERSONAL & ADV INJURY \$ 1,000,000	GENERAL AGGREGATE \$ 3,000,000	PRODUCTS - COM/OP AGG \$ 2,000,000
	AUTOMOBILE LIABILITY ANYAUTO ALL OWNED AUTOS HIRED AUTOS						COMBINED SINGLE LIMIT (Ea accident) \$	BODILY INJURY (Per person) \$	BODILY INJURY (Per accident) \$	PROPERTY DAMAGE (Per accident) \$	
	UMBRELLA LIAB EXCESS LIAB						EACH OCCURRENCE \$	AGGREGATE \$			
	WORKERS COMPENSATION AND EMPLOYERS' LIABILITY ANY PROPRIETOR/PARTNER/EXECUTIVE OFFICER/MEMBER EXCLUDED? (Mandatory in NH) If yes, describe under DESCRIPTION OF OPERATIONS below						PER STATUTE	OTH-ER	E.L. EACH ACCIDENT \$	E.L. DISEASE - EA EMPLOYEE \$	E.L. DISEASE - POLICY LIMIT \$
A	PHYSICAL AND/OR SEXUAL ABUSE LIABILITY			MSJ0427789128	02/01/21	02/01/22	OCCURENCE: \$ 100,000	AGGREGATE: \$ 300,000			

DESCRIPTION OF OPERATIONS / LOCATIONS / VEHICLES (ACORD 101, Additional Remarks Schedule, may be attached if more space is required)
*****SPECIAL EVENT CERTIFICATE*****
Event: **Wild Fish Open Water Swim**
Date: **8/7/2021**
Certificate holder is named as additional insured.

CERTIFICATE HOLDER City of Salem 93 Washington Street Salem MA 01970	CANCELLATION SHOULD ANY OF THE ABOVE DESCRIBED POLICIES BE CANCELLED BEFORE THE EXPIRATION DATE THEREOF, NOTICE WILL BE DELIVERED IN ACCORDANCE WITH THE POLICY PROVISIONS. AUTHORIZED REPRESENTATIVE
--	---



CITY OF SALEM, MASSACHUSETTS
PARK, RECREATION & COMMUNITY SERVICE
 401 Bridge Street, Salem MA 01970
 Tel. (978) 744-0180/(978) 744-0924
 pobrien@salem.com

Kimberley Driscoll
 MAYOR

Trish O'Brien
 Superintendent

Road Bike/Race/Walk/Parade Application

**PLEASE SUBMIT PAYMENT OF \$200 WITH THIS PERMIT APPLICATION TO THE CITY OF SALEM
 PARK, RECREATION AND COMMUNITY SERVICES DEPARTMENT NO LATER THAN 45 DAYS
PRIOR TO THE EVENT.
 Registered Non-Profit Fee \$150
**ANY FOR PROFIT EVENTS WILL REQUIRE AN ADDITIONAL 5% FROM THE
 REGISTRATION FEES POST EVENT.****

We, the undersigned, respectfully apply for permission to host a road race/walk in the City of Salem as follows:

Applicant's Name: CAROL A. MEYER

Organization Name: SALEM YMCA

Name of Race/Walk/Parade: WITCH CITY 5K

Contact #: 978 804 8170 E-Mail Address: meycar@northshoreymca.org

Address: 1 SEWELL

City/State/Zip: SALEM, MA 01970

Organization Tax Status (please include Tax ID Number): NON-PROFIT 042-104-913

What Charities Will This Race/Walk Be Benefiting? SALEM YMCA

Approximately How Much of the Race/Walk/Parade Proceeds Will Be Donated to Each Charity(s)
100%

Day of Race/Walk Contact Information:
 Name: CAROL A. MEYER Contact #: 978 804 8170

Date of Event: 10.16.21 Estimated Number of Participants: 600

Time of Event: 9:00 AM Estimated Finish Time of Event: 11:30 AM

Start Location: SALEM WILLOWS @ RESTAURANT ROW Finish Location: SALEM WILLOWS @ BEACH

Distance of Event: 5K

Has This Event Been Held Before? Yes No

DRM

KMM

All Races/Walks/Parades Are Required to Recycle and Remove Trash.

Please Explain Your Plan (Will You Bring to North Shore Recycled Fiber on 53 Jefferson Ave, Open M-F; Bring to Your Home Curbside, or Other?) If You Have Questions about Recycling, Please Contact Julie Rose for More Information 978-619-5679

Onsite EMT/Ambulance Service (Required): con initial

Please Attach a Map of Route With the Following Items:

1. ✓ Race/Walk Course
2. ✓ Direction of Runners Through the Race/Walk course
3. ✓ Starting and Finishing Points
4. ✓ Meeting Points For Racers Before and After the Race/Walk
5. Last year's race financials

Certificate of Insurance Attached? Yes No
RENEW IN APR

A certificate of insurance for general liability naming the City of Salem as primary additional insured for amount not less than \$1,000,000 combined single limit for injury or death or property damages (including loss of use) in any one occurrence, and \$1,000,000 general aggregate coverage. (The City of Salem reserves the right to increase coverage minimum if event presents extraordinary risk).

RELEASE & INDEMNITY AGREEMENT APPLICANT'S SIGNATURE The undersigned Sponsor, by signature below, shall defend, indemnify, and hold the City of Salem, its officers, agents and employees, harmless against all liability, loss, or expenses, including attorney's fees, and against all claims, actions or judgments based upon or arising out of damage or injury (including death) to persons or property caused by any act or omission of an act sustained in any way in connections with the performance of this event or by conditions created thereby, or based upon violation of any statute, ordinance or regulation. This contractual indemnity provision does not abrogate common law or statutory liability and indemnification to the City of Salem, but is in addition to such common law or statutory provisions. K. McCarthy

Date: 03/05/2021

Applicant's signature

Kevin McCarthy

Name of applicant

A copy of this permit will be sent to the applicant upon approval. Please call Park, Recreation & Community Services if you have any questions. 978-744-0924

CITY USE ONLY

Payment Received: _____ Date Permit Issued: _____ Date Permit Mailed to Applicant: _____
Approved By: _____

Director (Or Designee) of Salem Park, Recreation & Community Services

Salem Police Department

Effective date of form: 2/8/12
Revised date of form: 1/1/18

Witch City 5K Salem MA

Measured 7/23/17 By Steve Vaitones

- Start:** Restaurant Row at intersection of Fort Ave, heading NW
 89°6' SE of pole 1841 on parking lot side
 277° SE of Hydrant on Willows Park side
 2°8' SE of curb along park at intersection
- West** on Restaurant Row, merge into Memorial, merge into Szetela
 Cross Webb onto Essex
- 1 Mile:** 2 1/2 Essex at tree between two windows after door
 Continue on Essex, Left on Hawthorne Blvd access street closest to buildings
 Left on Derby, East on Derby
- 2 Mile:** In front of #50 Derby, 4' before front steps
 Continue on Derby, merge into Fort, bear left at Columbus
- 3 Mile:** 13'6" past pole 1844 on Left at parking drive-through
Finish: Dead Horse Beach entrance, prior to Memorial
 At beginning of retaining wall after access opening in wall
 22" before water cap in street

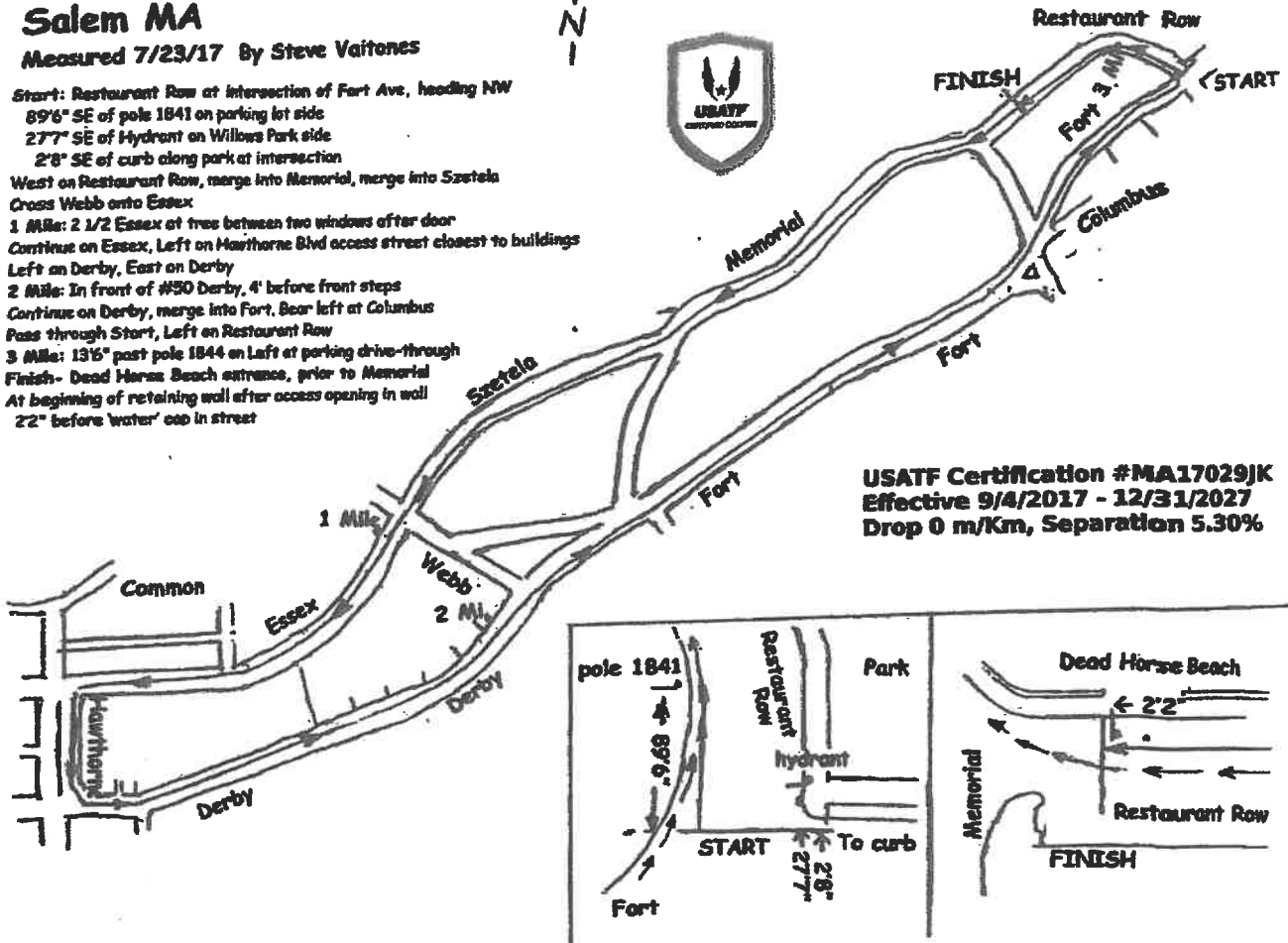

USATF Certification #MA17029JK
 Effective 9/4/2017 - 12/31/2027
 Drop 0 m/Km, Separation 5.30%

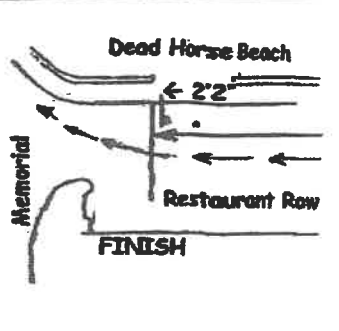
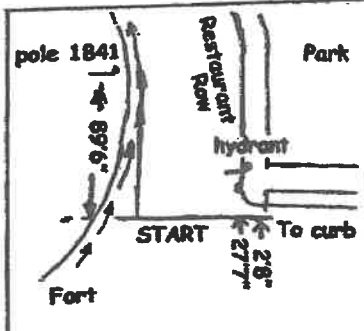



Road Running Technical Council
USA Track & Field
Measurement Certificate



Name of the course Witch City 5K Distance 5 km
 Location (state) MA (city) Salem
 Type of course: road race calibration course
 Measuring method: bicycle steel tape electronic distance meter
 Measured by (name, address, phone & e-mail) Steve Valtones, 90 Summit St, Waltham MA 02451
978-973-9873; svaltones@usatfinc.org
 Race contact (name, address, phone & e-mail) Tim Short, 40 Leggs Hill Rd, Marblehead MA 01945
978-479-2738; shortt@northshoreymca.org
 Date(s) when course measured: Jul 23, 2017
 Number of measurements of entire course: 2 Course Configuration: one loop, one time
 Elevation (meters above sea level) Start 3 m Finish 3 m Highest 10 m Lowest 2 m
 Straight line distance between start & finish 265 m Drop 0 m/km Separation 5.30 %
 Type of surface: paved 100 % dirt - % gravel - % grass - % track - %
 Effective date of certification: Sep 4, 2017 Certification code: MA17029JK

Notice to Race Director: Use this Certification Code in all public announcements relating to your race.

Be It Officially Noted That

Based on examination of data provided by the above named measurer, the course described above and in the map attached is hereby certified as reasonably accurate in measurement according to the standards adopted by the Road Running Technical Council. If any changes are made to the course, this certification becomes void, and the course must then be recertified.

Verification of Course — In the event a National Open Record is set on this course, or at the discretion of USA Track & Field, a verification remeasurement may be required to be performed by a member of the Road Running Technical Council. If such a remeasurement shows the course to be short, then all pending records will be rejected and the course certification will be cancelled.

This certification expires on December 31 in the year

2027

AS NATIONALLY CERTIFIED BY:

Justin Kuo

Date: Sep 6, 2017

Justin Kuo USATF/RRTC Course Certifier • 39 Oakland Road, Brookline, MA 02445-6700
 Phone: 617-731-9889 • Fax: 617-939-0992 • Email: jkuo@usatfinc.org

RACM



CERTIFICATE OF LIABILITY INSURANCE

DATE (MM/DD/YYYY)
4/5/2021

THIS CERTIFICATE IS ISSUED AS A MATTER OF INFORMATION ONLY AND CONFERS NO RIGHTS UPON THE CERTIFICATE HOLDER. THIS CERTIFICATE DOES NOT AFFIRMATIVELY OR NEGATIVELY AMEND, EXTEND OR ALTER THE COVERAGE AFFORDED BY THE POLICIES BELOW. THIS CERTIFICATE OF INSURANCE DOES NOT CONSTITUTE A CONTRACT BETWEEN THE ISSUING INSURER(S), AUTHORIZED REPRESENTATIVE OR PRODUCER, AND THE CERTIFICATE HOLDER.

IMPORTANT: If the certificate holder is an ADDITIONAL INSURED, the policy(ies) must be endorsed. If SUBROGATION IS WAIVED, subject to the terms and conditions of the policy, certain policies may require an endorsement. A statement on this certificate does not confer rights to the certificate holder in lieu of such endorsement(s).

PRODUCER Hays Companies Inc. 133 Federal Street, 4th Floor Boston MA 02110	CONTACT NAME: Moira Crosby PHONE (A/C, No, Ext): E-MAIL ADDRESS: mcrosby@hayscompanies.com	FAX (A/C, No):
	INSURER(S) AFFORDING COVERAGE	
INSURED YMCA of the North Shore 200 Cummings Center, Suite 173D PO Box 7073 Beverly MA 01915	INSURER A: United States Fire Insurance Company	NAIC # 21113
	INSURER B: The North River Insurance Company	NAIC # 21105
	INSURER C: New Hampshire Employers Insurance Comp	NAIC # 13083
	INSURER D:	
	INSURER E:	
	INSURER F:	

COVERAGES **CERTIFICATE NUMBER:** 21-22 GL Auto UMB WC **REVISION NUMBER:**

THIS IS TO CERTIFY THAT THE POLICIES OF INSURANCE LISTED BELOW HAVE BEEN ISSUED TO THE INSURED NAMED ABOVE FOR THE POLICY PERIOD INDICATED. NOTWITHSTANDING ANY REQUIREMENT, TERM OR CONDITION OF ANY CONTRACT OR OTHER DOCUMENT WITH RESPECT TO WHICH THIS CERTIFICATE MAY BE ISSUED OR MAY PERTAIN, THE INSURANCE AFFORDED BY THE POLICIES DESCRIBED HEREIN IS SUBJECT TO ALL THE TERMS, EXCLUSIONS AND CONDITIONS OF SUCH POLICIES. LIMITS SHOWN MAY HAVE BEEN REDUCED BY PAID CLAIMS.

INSR LTR	TYPE OF INSURANCE	ADDL INSD	SUBR WVD	POLICY NUMBER	POLICY EFF (MM/DD/YYYY)	POLICY EXP (MM/DD/YYYY)	LIMITS
A	<input checked="" type="checkbox"/> COMMERCIAL GENERAL LIABILITY <input type="checkbox"/> CLAIMS-MADE <input type="checkbox"/> OCCUR GEN'L AGGREGATE LIMIT APPLIES PER: <input checked="" type="checkbox"/> POLICY <input type="checkbox"/> PRO-JECT <input type="checkbox"/> LOC OTHER:			543-227910-3	4/1/2021	4/1/2022	EACH OCCURRENCE \$ 1,000,000 DAMAGE TO RENTED PREMISES (Ea occurrence) \$ 100,000 MED EXP (Any one person) \$ 5,000 PERSONAL & ADV INJURY \$ 1,000,000 GENERAL AGGREGATE \$ 2,000,000 PRODUCTS - COMP/OP AGG \$ 1,000,000 Employee Benefits \$
A	AUTOMOBILE LIABILITY <input checked="" type="checkbox"/> ANY AUTO <input type="checkbox"/> ALL OWNED AUTOS <input type="checkbox"/> SCHEDULED AUTOS <input type="checkbox"/> HIRED AUTOS <input type="checkbox"/> NON-OWNED AUTOS			133-749501-3	4/1/2021	4/1/2022	COMBINED SINGLE LIMIT (Ea accident) \$ 1,000,000 BODILY INJURY (Per person) \$ BODILY INJURY (Per accident) \$ PROPERTY DAMAGE (Per accident) \$ \$
B	<input checked="" type="checkbox"/> UMBRELLA LIAB <input type="checkbox"/> OCCUR <input type="checkbox"/> EXCESS LIAB <input type="checkbox"/> CLAIMS-MADE DED RETENTION \$			582-116100-3	4/1/2021	4/1/2022	EACH OCCURRENCE \$ 8,000,000 AGGREGATE \$ 8,000,000 \$
C	WORKERS COMPENSATION AND EMPLOYERS' LIABILITY ANY PROPRIETOR/PARTNER/EXECUTIVE OFFICER/MEMBER EXCLUDED? (Mandatory in NH) If yes, describe under DESCRIPTION OF OPERATIONS below	Y/N	N/A	ECC-600-4000020-2021A	1/1/2021	1/1/2022	<input checked="" type="checkbox"/> PER STATUTE <input type="checkbox"/> OTH-ER E.L. EACH ACCIDENT \$ 500,000 E.L. DISEASE - EA EMPLOYEE \$ 500,000 E.L. DISEASE - POLICY LIMIT \$ 500,000

DESCRIPTION OF OPERATIONS / LOCATIONS / VEHICLES (ACORD 101, Additional Remarks Schedule, may be attached if more space is required)
RE: Witch City Road Race (5K) - October 2021

The City of Salem is included as an Additional Insured with regards to the General Liability Coverage, per the terms and conditions of the Policy, where required by written contract.

CERTIFICATE HOLDER City of Salem Parks and Rec Department 401 Bridge Street Salem, MA	CANCELLATION SHOULD ANY OF THE ABOVE DESCRIBED POLICIES BE CANCELLED BEFORE THE EXPIRATION DATE THEREOF, NOTICE WILL BE DELIVERED IN ACCORDANCE WITH THE POLICY PROVISIONS. AUTHORIZED REPRESENTATIVE James Hays/MCROSB 
--	---



CITY OF SALEM, MASSACHUSETTS
PARK, RECREATION & COMMUNITY SERVICE
 401 Bridge Street, Salem MA 01970
 Tel. (978) 744-0180/(978) 744-0924
 pobrien@salem.com

Kimberley Driscoll
 MAYOR

Trish O'Brien
 Superintendent

Road Bike/Race/Walk/Parade Application

**PLEASE SUBMIT PAYMENT OF \$200 WITH THIS PERMIT APPLICATION TO THE CITY OF SALEM
 PARK, RECREATION AND COMMUNITY SERVICES DEPARTMENT NO LATER THAN 45 DAYS
PRIOR TO THE EVENT.
 Registered Non-Profit Fee \$150
 ANY FOR PROFIT EVENTS WILL REQUIRE AN ADDITIONAL 5% FROM THE
 REGISTRATION FEES POST EVENT.**

We, the undersigned, respectfully apply for permission to host a road race/walk in the City of Salem as follows:

Applicant's Name: CARIL A. MEYER
 Organization Name: SALEM YMCA
 Name of Race/Walk/Parade: SALEM ROAD RACE / Notch 10K
 Contact #: CARIL A. MEYER E-Mail Address: meyerc@northshoreymca.org
 Address: 1 SEWELL ST
 City/State/Zip: SALEM, MA 01970
 Organization Tax Status (please include Tax ID Number): 042-104-913
 What Charities Will This Race/Walk Be Benefiting? SALEM YMCA
 Approximately How Much of the Race/Walk/Parade Proceeds Will Be Donated to Each Charity(s)
\$ 10,000
 Day of Race/Walk Contact Information:
 Name: ED O'CONNOR Contact #: 617 398 0611
 Date of Event: 9.12.21 Estimated Number of Participants: 2500
 Time of Event: 10:00 AM Estimated Finish Time of Event: 11:00 - 11:30
 Start Location: CONGRESS ST @ NOTCH BREWING Finish Location: SAME
 Distance of Event: 10K
 Has This Event Been Held Before? Yes No

DRM

All Races/Walks/Parades Are Required to Recycle and Remove Trash.

Please Explain Your Plan (Will You Bring to North Shore Recycled Fiber on 53 Jefferson Ave, Open M-F; Bring to Your Home Curbside, or Other?) If You Have Questions about Recycling, Please Contact Julie Rose for More Information 978-619-5679

Onsite EMT/Ambulance Service (Required): CM initial

Please Attach a Map of Route With the Following Items:

1. Race/Walk Course
2. Direction of Runners Through the Race/Walk course
3. Starting and Finishing Points
4. Meeting Points For Racers Before and After the Race/Walk
5. Last year's race financials

Certificate of Insurance Attached? ___ Yes No Renews in April CM

A certificate of insurance for general liability naming the City of Salem as primary additional insured for amount not less than \$1,000,000 combined single limit for injury or death or property damages (including loss of use) in any one occurrence, and \$1,000,000 general aggregate coverage. (The City of Salem reserves the right to increase coverage minimum if event presents extraordinary risk).

RELEASE & INDEMNITY AGREEMENT APPLICANT'S SIGNATURE The undersigned Sponsor, by signature below, shall defend, indemnify, and hold the City of Salem, its officers, agents and employees, harmless against all liability, loss, or expenses, including attorney's fees, and against all claims, actions or judgments based upon or arising out of damage or injury (including death) to persons or property caused by any act or omission of an act sustained in any way in connections with the performance of this event or by conditions created thereby, or based upon violation of any statute, ordinance or regulation. This contractual indemnity provision does not abrogate common law or statutory liability and indemnification to the City of Salem, but is in addition to such common law or statutory provisions. Kevin McCarthy

03/03/2021

Date:

Applicant's signature

Kevin McCarthy

Name of applicant

A copy of this permit will be sent to the applicant upon approval. Please call Park, Recreation & Community Services if you have any questions. 978-744-0924

CITY USE ONLY

Payment Received: _____ Date Permit Issued: _____ Date Permit Mailed to Applicant: _____

Approved By:

Director (Or Designee) of Salem Park, Recreation & Community Services

Capt. Mark Towle
Salem Police Department

5-17-21 → Tentative approval providing a submitted plan and approval by Health Dept.

Effective date of form: 2/8/12

Revised date of form: 1/1/18

ACKNOWLEDGEMENT OF RECEIPT OF POLICY

The undersigned, an applicant of a permit, for use of a playing field, court, beach, venue, and/or related facilities, acknowledges that the undersigned has received and read a copy of the City of Salem "Field/Court and Facility Permit Policy", and understands and will fully abide by the terms, conditions and provisions contained or referred to therein.

The undersigned, in agreeing to rent and/or reserve the City of Salem's Parks and Recreation fields and/or facilities, and in consideration for permission to do so, I/we agree to forever release, discharge, and covenant to hold harmless the City of Salem, and its successors, departments, officers, employees, servants, and agents of and from any and all actions, causes for actions, claims, demands, damages, or costs of any kind which may result, directly or indirectly, from the use of City-owned recreational fields and facilities, and agreeing not to bring suit against the City for any claim arising in any way from their use. I/we also agree to defend and INDEMNIFY the City of Salem, and its successors, departments, officers, employees, servants and agents, against any actions brought in law or equity for damages arising out of use of the fields, playgrounds, beaches and/or facilities, including attorney's fees.

	03/03/2021
-----	-----
Signature	date
Kevin McCarthy	CFO
-----	-----
Print name	org. position

CHECKLIST FOR PERMIT APPLICATION: No action will be taken on permit application until all aspects are complete.

CHECKLIST FOR TEAMS/LEAGUES APPLYING FOR SALEM FIELD USE

- 1) Completed application with signed acknowledgement of "Receipt of Policy" statement.
- 2) Rosters for every youth team, signed by league administrator/director, authenticating residency requirements for Tier 2 and 3 users.
- 3) Copy of Drivers licenses of all adults that are participating in a team/league, as supporting the residency requirements of Tiers 2-5.
- 4) For all youth organizations using Salem Fields/courts, a list of all volunteers and a letter from the organization's administrators stating that all volunteers have been CORI checked as required by Mass. State laws and a copy of the letter from the States CORI office stating that your CORI Administrator has been approved by the state.

NOTE: This form is to be returned with the permit application indicating that the applicant has read and agrees to the terms listed in this document.

COURSE ON GOOGLE MAPS

Street by Street:

The race starts and finishes on Congress St (near Notch Brewing). Runners turn right on Derby St, continue to Fort Ave, turn left on park access road near tennis courts, left on Restaurant Row, bear right on Memorial Dr, right on Szetela Ln, continue on Essex St, left on Hawthorne Blvd, right on Derby St, left on Lafayette St, left on West Ave, right on Forrest River Park loop, right on Shore Ave to Ocean Ave, right on Summit Ave, right on Willow Ave, left on JM Walsh Sq, right on Messervy St, left on Green St, right on Leach St, left on Lafayette Pl, continue to Palmer Cove Park footpath, right on Leavitt St, left on Pingree St, left on Lynch St, right on Congress St then continue to finish near Congress & Derby.





Road Running Technical Council
USA Track & Field



Measurement Certificate

Name of the course Salem Road Race 10K Distance 10.0 km
 Location (state) Massachusetts (city) Salem
 Type of course: road race calibration course
 Measuring method: bicycle steel tape electronic distance meter
 Measured by (name, address, phone & e-mail) Bob Kennedy, 18 Riverview Road, Durham, NH 03824
508-577-4105, osprey02554@yahoo.com
 Race contact (name, address, phone & e-mail) Ed O'Connor, 177 Endicott St, Boston, MA 02113
617-398-0611 ed@cambridge5k.com
 Date(s) when course measured: August 15, 2017
 Number of measurements of entire course: 2 Course Configuration: Figure 8
 Elevation (meters above sea level) Start 3 m Finish 3 m Highest 12 m Lowest 3 m
 Straight line distance between start & finish 215 m Drop 0.0 m/km Separation 1.02 %
 Type of surface: paved 100 % dirt % gravel % grass % track %
 Effective date of certification: August 25, 2017 Certification code: MA17006BK

Notice to Race Director: Use this Certification Code in *all* public announcements relating to your race.

Be It Officially Noted That

Based on examination of data provided by the above named measurer, the course described above and in the map attached is hereby certified as reasonably accurate in measurement according to the standards adopted by the Road Running Technical Council. If *any* changes are made to the course, this certification becomes void, and the course must then be recertified.

Verification of Course — In the event a National Open Record is set on this course, or at the discretion of USA Track & Field, a verification remeasurement may be required to be performed by a member of the Road Running Technical Council. If such a remeasurement shows the course to be short, then all pending records will be rejected and the course certification will be cancelled.

This certification expires on December 31 in the year 2027

AS NATIONALLY CERTIFIED BY:

Bob Kennedy Date: August 25, 2017
 Bob Kennedy – USATF/RRTC Certifier
 18 Riverview Road, Durham, NH 03824, 508-577-4105, osprey02554@yahoo.com



May 25, 2021

Patricia O'Brien
City of Salem
93 Washington St
Salem, MA 01970

Re: Salem Road Race [09-12-21] - Insurance Coverage

Patricia -

Attached you will find a copy of our COI from last year and a payment receipt for this year's renewal from USA Track & Field.

The race committee would appreciate it if the City Clerk would allow our permit application to be considered at this week's City Council meeting.

Thank you,

Edward O'Connor

Edward O'Connor
C5K Sports
177 Endicott St
Boston, MA 02113

CERTIFICATE OF INSURANCE

PRINT DATE: 6/14/2021

CERTIFICATE NUMBER: 20210613831948

AGENCY:

Edgewood Partners Insurance Center
2727 Paces Ferry Road, Building Two, Suite 1500
Atlanta, GA 30339
678-324-3300 (Phone), 678-324-3303 (Fax)

THIS CERTIFICATE IS ISSUED AS A MATTER OF INFORMATION ONLY AND CONFERS NO RIGHTS UPON THE CERTIFICATE HOLDER. THIS CERTIFICATE DOES NOT AMEND, EXTEND OR ALTER THE COVERAGE AFFORDED BY THE POLICIES BELOW.

NAMED INSURED:

USA Track & Field, Inc. C5K Sports
130 East Washington Street, Suite 800
Indianapolis IN 46204

INSURERS AFFORDING COVERAGE:

INSURER A: Philadelphia Indemnity Ins. Co. NAIC #: 18058

EVENT INFORMATION:

Salem Road Race (9/12/2021 - 9/13/2021)

POLICY/COVERAGE INFORMATION:

THE POLICIES OF INSURANCE LISTED BELOW HAVE BEEN ISSUED TO THE INSURED NAMED ABOVE FOR THE POLICY PERIOD INDICATED. NOTWITHSTANDING ANY REQUIREMENT, TERM OR CONDITION OF ANY CONTRACT OR OTHER DOCUMENT WITH RESPECT TO WHICH THIS CERTIFICATE MAY BE ISSUED OR MAY PERTAIN, THE INSURANCE AFFORDED BY THE POLICIES DESCRIBED HEREIN IS SUBJECT TO ALL THE TERMS, EXCLUSIONS AND CONDITIONS OF SUCH POLICIES. AGGREGATE LIMITS SHOWN MAY HAVE BEEN REDUCED BY PAID CLAIMS.

INS	TYPE OF INSURANCE:	POLICY NUMBER(S):	EFFECTIVE:	EXPIRES:	LIMITS:
A	GENERAL LIABILITY				
	X Occurrence	PHPK2197728	11/1/2020 12:01 AM	11/1/2021 12:01 AM	GENERAL AGGREGATE (Applies Per Event) \$3,000,000
	X Host Liquor Liability				EACH OCCURRENCE \$1,000,000
	X Participant Legal Liability				DAMAGE TO RENTED PREMISES (Each Occ.) \$1,000,000
					MEDICAL EXPENSE (Any one person) EXCLUDED
					PERSONAL & ADV INJURY \$1,000,000
					PRODUCTS-COMP/OP AGG \$3,000,000
A	UMBRELLA/EXCESS LIABILITY				
	X Occurrence	PHUB743472	11/1/2020 12:01 AM	11/1/2021 12:01 AM	EACH OCCURRENCE \$10,000,000
					AGGREGATE \$10,000,000

DESCRIPTION OF OPERATIONS/LOCATIONS/VEHICLES/EXCLUSIONS ADDED BY ENDORSEMENT/SPECIAL PROVISIONS:

Coverage applies to USA Track & Field sanctioned events and registered practices, including any directly related activities, such as event set-up and tear-down, participant check-in and award ceremonies.

The certificate holder is an additional insured per the following endorsement: Additional Insured - Certificate Holders (Form PI-AM-002)

The General Liability policy is primary and non-contributory with respect to the negligence of the Named Insureds (Form CG 00 01)

The General Liability policy contains a blanket Waiver of Subrogation as required by contract per Waiver of Transfer of Rights of Recovery Against Others (Form CG 24 04).

Excess policy follows form of underlying General Liability.

CERTIFICATE HOLDER:

City of Salem
93 Washington St
Salem MA 01970

NOTICE OF CANCELLATION:

Should any of the above described policies be cancelled before the expiration date thereof, notice will be delivered in accordance with the policy provisions.

AUTHORIZED REPRESENTATIVE:

USATF Event Sanction Application Confirmation

sanctions@usatf.org

USATF Event Sanction Application Confirmation

Your event location application for the 2023 USATF National USATF and the USATF Association to which the event is taking place will review the application and advise you of any changes within 7-10 business days for non-emergency cases. Please note that the review process for emergency cases may vary. The following information will be reviewed and shared upon approval of the event sanction application.

Sanction Number:	13-02-020
Event Name:	2023 USATF National
Event Location:	Atlanta, GA, US
Event Dates:	08/24-08/26
Event Time:	10:00 AM

Please note that the review process for emergency cases may vary.

Approved Details

Event Name: 2023 USATF National

Event Location: Atlanta, GA, US

Event Dates: 08/24-08/26

Event Time: 10:00 AM

Sanction Number: 13-02-020

Event Name: 2023 USATF National

Event Location: Atlanta, GA, US

Event Dates: 08/24-08/26

Event Time: 10:00 AM

Sanction Number: 13-02-020

Event Name: 2023 USATF National

Event Location: Atlanta, GA, US

Event Dates: 08/24-08/26

Event Time: 10:00 AM



CITY OF SALEM

In City Council,

May 27, 2021

Ordered:

Fiscal Year 2022 General Fund Capital Improvement Program Funded from Bond Authorization as amended below:

That the sum of \$9,819,000 be and hereby is appropriated to pay costs of the following capital equipment and capital improvement projects listed under the heading FY22 CIP- Funded from BOND AUTHORIZATION and for the payment of all costs incidental and related thereto, and that to meet said appropriation the Treasurer, with the approval of the Mayor, is authorized to borrow said sum under M.G.L. Chapter 44, Section 7, or pursuant to any other enabling authority, and to issue bonds or notes of the City therefor.

FY22 CIP-Funded from BOND AUTHORIZATION			
Engineering	Roads, Sidewalks & Crosswalks (Non Chapter 90 eligible, includes Bridge, Boston, Washington, Essex, Other)		\$ 1,500,000
Engineering	Citywide Seawall Improvements		\$ 200,000
Engineering	McGrath Park Soils Redemption		\$ 200,000
Engineering	Derby Street Complete Project Phase 3		\$ 560,000
Fire	New Engine to Replace Engine 1		\$ 662,000
IT	Annual Equipment-Life-Cycle Mgmt Program (City)		\$ 125,000
Library	General Building Upgrades, Improvements, Envelope, ADA		\$ 85,000
Recreation	Golf Course Cart Paths (CPA)		\$ 426,000
Recreation	City Wide Playgorund Equipmen, Court, Minor Park Repairs		\$ 100,000
Recreation	Park and Recreation Major Improvements/ADA		\$ 100,000
Recreation	Willows Pier		\$ 900,000
Parking and Traffic	Traffic Calming Improvements		\$ 70,000
Parking and Traffic	Bicycle Infrastructure Design, Implementation & Repairs/Improvements		\$ 100,000
Parking and Traffic	Museum Place Garage Renovation Phase 2		\$ 1,580,000
Parking and Traffic	South Harbor Garage Stair Replacement & ADA Compliance		\$ 850,000
Parking and Traffic	MP & SH Garage Maintenance, Repairs, ADA		\$ 100,000
Planning	OTH Restorations & Systems Assesment, Planning, Design		\$ 100,000
Police	Police & Fire Radio Communication System		\$ 250,000
Police	Vehicle Replacement Program		\$ 150,000
Public Scvices - Equipment	Annual Small Repairs, DPS Building Studies and ADA Improvements - DPS & Cemeteries		\$ 75,000
Public Scvices - Equipment	Salem DPS Salt Shed Project		\$ 420,000
Public Scvices - Equipment	Replace Primary Sweeper		\$ 241,000

Schools	School Life Safety, MEP, Utility, Roof Repairs, Upgrades, Studies		\$ 150,000
Schools	Collins Roof/Masonry Study/Repair		\$ 125,000
Schools	District Camera and Access Control		\$ 250,000
Schools	Energy/Water Upgrades and Audits		\$ 125,000
Schools	Witchcraft Heights Floor Replacement		\$ 300,000
Schools	ADA/Architectural/Interior, Site Repairs, Upgrades, Studies		\$ 75,000
	Schools		
TOTAL BOND AUTHORIZATION:			\$ 9,819,000

Any premium received upon the sale of any bonds or notes approved by this vote, less any such premium applied to the payment of the costs of issuance of such bonds or notes, may be applied to the payment of costs approved by this vote in accordance with Chapter 44, Section 20 of the General Laws, thereby reducing the amount authorized to be borrowed to pay such costs by a like amount.

Be it further **Ordered**:

That the Mayor and the Treasurer are each authorized to file an application to qualify under Chapter 44A of the Massachusetts General Laws any and all bonds of the City issued under and pursuant hereto, and to provide such information and execute such documents as may be required in connection therewith.

In City Council May 27, 2021

Referred to the Committee on Administration and Finance co-posted with the Committee of the Whole
In City Council June 10, 2021

Adopted for first passage by a roll call vote of 9 yeas, 2 nays, and 0 absent

ATTEST:

ILENE SIMONS
CITY CLERK



CITY OF SALEM

In City Council,

May 27, 2021

Ordered:

Fiscal Year 2022 Water and Sewer Capital Improvement Program Funded from Bond Authorization as amended below:

That the sum of \$4,429,000 be and hereby is appropriated to pay costs of the following capital equipment and capital improvement projects listed under the heading FY22 CIP – Funded from BOND AUTHORIZATION and for the payment of all costs incidental and related there to, and that to meet said appropriation the Treasurer, with the approval of the Mayor, is authorized to borrow said sum under M.G.L. Chapter 44, Sections 7 and/or 8, or pursuant to any other enabling authority, and to issue bonds or notes of the City therefor.

FY22 CIP-Funded from BOND AUTHORIZATION		
Water	Citywide Flushing, valve excercise, leak detection, GIS	\$ 400,000.00
Water	Folly Hill Water Tank Upgrades/Major Repairs	\$ 345,000.00
Water	Highland Ave 16 inch Water Main	\$ 300,000.00
Water	Water Distribution Main System Improvements	\$ 800,000.00
Water	Water Meter Reader Truck	\$ 34,000.00
Water	Water Transmission Main System Improvements	\$ 400,000.00
Water	Loring Ave. 16 Ince Water Main Replacement	\$ 200,000.00
Sewer	Community Wide Climate Change/Stormwater/Watershed Model and Outreach	\$ 50,000.00
Sewer	Citywide Drain & Sewer Flushing, Pipe Replacements, Sewer Extensions, GIS	\$1,450,000.00
Sewer	Ocean Ave Sewer Pump Station Design	\$ 150,000.00
Sewer	SSES Report Implementation (eliminate I/I sources citywide)	\$ 300,000.00
TOTAL BOND AUTHORIZATION:		\$ 4,429,000

Any premium received upon the sale of any bonds or notes approved by this vote, less any such premium applied to the payment of the costs of issuance of such bonds or notes, may be applied to the payment of costs approved by this vote in accordance with Chapter 44, Section 20 of the General Laws, thereby reducing the amount authorized to be borrowed to pay such costs by a like amount.

Be it further Ordered:

That the Mayor and the Treasurer are each authorized to file an application to qualify under Chapter 44A of the Massachusetts General Laws any and all bonds of the City issued under and pursuant hereto, and to provide such information and execute such documents as may be required in connection therewith.

In City Council May 27, 2021

Referred to the Committee on Administration and Finance co-posted with the Committee of the Whole

In City Council June 10, 2021

Adopted for first passage by a roll call vote of 9 yeas, 2 nays and 0 absent

ATTEST:

ILENE SIMONS
CITY CLERK

CITY OF SALEM

In the year Two Thousand and Twenty-One

An Ordinance to amend an Ordinance relative to Rates for Use of Water

Be it ordained by the City Council of the City of Salem, as follows:

Section 1. Chapter 46, Section 66 is hereby amended by deleting subparagraph (b) in its entirety and replacing it with the following:

“(b) The rate for all water furnished by meter measurements effective July 1, 2021 shall be as follows:

- (1) Residential, per 100 cubic feet \$3.64
- (2) Nonresidential, per 100 cubic feet \$4.92

Section 2. Chapter 46, Section 66 is hereby further amended by deleting subparagraph (e) in its entirety and replacing it with the following:

“(e) The minimum rate for residential metered water for each quarter shall be \$36.40 per 1000 cubic feet effective July 1, 2021.

The use of all water and sewer funds and SESD funds shall be excluded from all private development projects.”

Section 3. This Ordinance shall take effect as provided by City Charter.

In City Council May 27, 2021
Referred to the Committee on Ordinances, Licenses and Legal Affairs co-posted with the Committee of the Whole
In City Council June 10, 2021
Adopted for first passage by a roll call vote of 10 yeas, 1 nay and 0 absent
In City Council June 24, 2021

ATTEST:

ILENE SIMONS
CITY CLERK

CITY OF SALEM

In the year Two Thousand and Twenty-One

An Ordinance to amend an Ordinance relative to Sewer User Charges

Be it ordained by the City Council of the City of Salem, as follows:

Section I. Chapter 46, Section 230 is hereby amended by deleting subsection (c) in its entirety and replacing it with the following:

“(c) The rates for sewer use charges effective July 1, 2021 shall be as follows:

Residential, per 100 cubic feet...	\$ 7.41
Nonresidential, per 100 cubic feet up to 25,000 cubic feet per month	\$11.22
Nonresidential, per 100 cubic feet for 25,000 cubic feet and greater per month	\$14.37

The use of all water and sewer funds and SESD funds shall be excluded from all private development projects.”

Section II. This Ordinance shall take effect as provided by City Charter.

In City Council May 27, 2021

Referred to the Committee on Ordinances, Licenses and Legal Affairs co-posted with the Committee of the Whole

In City Council June 10, 2021

Adopted for first passage by a roll call vote of 10 yeas, 1 nay and 0 absent

In City Council June 24, 2021

ATTEST:

ILENE SIMONS
CITY CLERK

City of Salem

In the year Two Thousand and Twenty One

An Ordinance to amend an Ordinance relative to Traffic Ch. 42, Sec. 50B,
"Handicapped Zones, Limited Time"

Be it ordained by the City Council of the City of Salem, as follows:

Section I. Amending Chapter 42, Section 50B – "Handicapped Zones, Limited Time" is hereby amended by repealing the following:

Repeal - Mall Street – One Handicapped Parking Space in front of #9 Mall Street, for a distance of twenty (20) feet.

Section II. This Ordinance shall take effect as provided by City Charter.

In City Council June 10, 2021

Adopted for first passage by a roll call vote of 11 yeas, 0 nays and 0 absent

In City Council June 24, 2021

ATTEST:

ILENE SIMONS
CITY CLERK