

ORDER FOR CONDUIT & POLE LOCATION

In the City Council for the City of Salem, Massachusetts.

ORDERED:

That permission be and hereby is granted to Comcast Cable Communications Management LCC., to lay and maintain underground conduits, manholes and poles, with the wires and cables to be placed therein, under and above the surface of the following public way or ways as requested in petition of said Company dated April 9, 2021

First Street: Starting at the existing Comcast Manhole excavating to place (1) 4" PVC conduit 30'+/_ to number 40 First Street.

Substantially as shown on plan, filed with said petition.

Also that permission be and hereby is granted said Comcast to lay and maintain underground conduits, manholes, cables and wires in the above or intersecting public ways for the purpose of making connections with such poles and buildings as it may desire for distributing purposes.

The foregoing permission is subject to the following conditions:

1. The conduits and manholes shall be of such materials and construction and all work done in such manner as to be satisfactory to the City Council or to such officers as it may appoint to the supervision of the work.
2. Said Company shall indemnify and save the City harmless against all damages, costs and expense whatsoever to which the City may be subjected in consequence of the acts or neglect of said Company, its agents or servants, or in any manner arising from the rights and privileges granted it by the City.
3. In addition said Company shall, before a public way is disturbed for the laying of its wire or conduits, execute its bond in a penal sum of Fifty Thousand Dollars (\$50,000) (reference being had to the bond already on file with said City) conditioned for the faithful performance of its duties under this permit.
4. Said Company shall comply with the requirements of existing by-laws and such as may hereafter be adopted governing the construction and maintenance of conduits and wires, so far as the same are not inconsistent with the laws of the Commonwealth.

I hereby certify that the foregoing order was adopted at a meeting of the City Council for the City of Salem, Massachusetts, held on the _____ day of _____ 2021.

(over)

City Clerk

We hereby certify that on _____, 2021, at _____ o'clock M., at Salem, Massachusetts a public hearing was held on the petition of the Comcast for permission to lay and maintain underground conduits, manholes and connections, with the wires and cables to be placed therein, described in the order herewith recorded, that we mailed at least seven days before said hearing a written notice the time and place of said hearing to each of the owners of real estate determined by the last preceding assessment for taxation along the ways parts of ways upon which the Company is permitted to construct the lines said Company under said order. And that thereupon said order was duly adopted.

Salem City Council; Salem, Massachusetts

CERTIFICATE

I hereby certify that the foregoing is a true copy of a location order, and certificate of hearing with the notice adopted by the City Council for the City of Salem, Massachusetts, on the _____ day of _____, 2021, recorded with the records of location orders of said City, Book _____, Page _____. This certified copy is made under the provision of Chapter 166 of General Laws and any additions thereto or amendments thereof.

Attest:

City Clerk

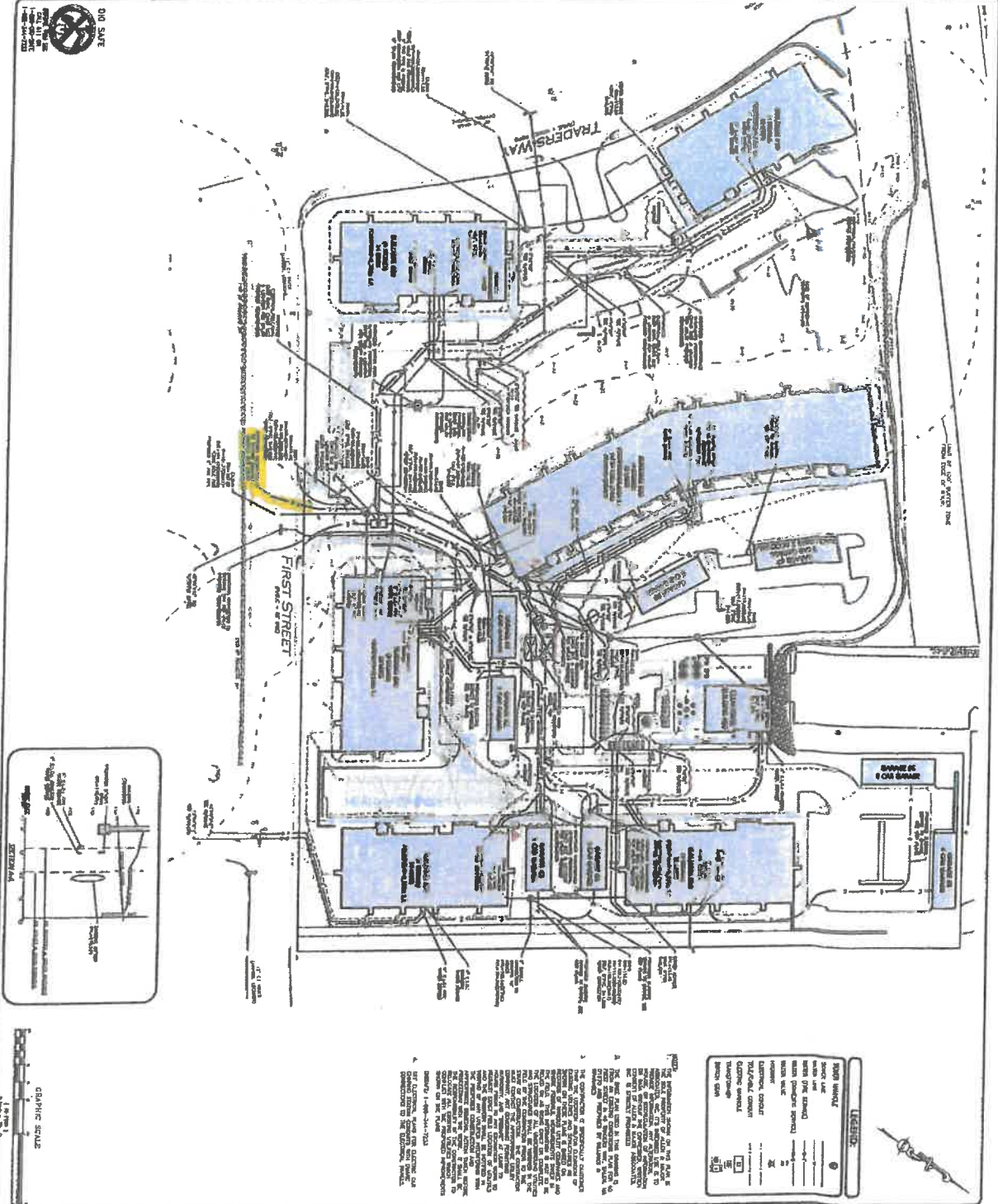

LEGEND	
ASPHALT DRIVE	---
CONCRETE DRIVE	---
PAVING	---
LANDSCAPING	---
...	---

1. THE INFORMATION SHOWN ON THIS PLAN IS THE PROPERTY OF ALLEN & MAJOR ASSOCIATES, INC. AND IS NOT TO BE REPRODUCED OR TRANSMITTED IN ANY FORM OR BY ANY MEANS, ELECTRONIC OR MECHANICAL, INCLUDING PHOTOCOPYING, RECORDING, OR BY ANY INFORMATION STORAGE AND RETRIEVAL SYSTEM, WITHOUT THE WRITTEN PERMISSION OF ALLEN & MAJOR ASSOCIATES, INC.

2. THE CLIENT HAS REVIEWED AND APPROVED THE INFORMATION SHOWN ON THIS PLAN AND HAS AGREED TO HOLD ALLEN & MAJOR ASSOCIATES, INC. HARMLESS FROM AND AGAINST ALL CLAIMS, DAMAGES, LOSSES AND EXPENSES, INCLUDING REASONABLE ATTORNEY'S FEES, ARISING OUT OF OR RESULTING FROM THE USE OF THIS PLAN.

3. THE INFORMATION SHOWN ON THIS PLAN IS FOR GENERAL INFORMATION ONLY AND IS NOT TO BE USED FOR ANY OTHER PURPOSES WITHOUT THE WRITTEN PERMISSION OF ALLEN & MAJOR ASSOCIATES, INC.

4. THE CLIENT HAS REVIEWED AND APPROVED THE INFORMATION SHOWN ON THIS PLAN AND HAS AGREED TO HOLD ALLEN & MAJOR ASSOCIATES, INC. HARMLESS FROM AND AGAINST ALL CLAIMS, DAMAGES, LOSSES AND EXPENSES, INCLUDING REASONABLE ATTORNEY'S FEES, ARISING OUT OF OR RESULTING FROM THE USE OF THIS PLAN.

CD/PERMIT SET

ALLEN & MAJOR ASSOCIATES, INC.
 10000 W. 10th Street, Suite 100
 Overland Park, KS 66211
 Phone: (913) 666-1100
 Fax: (913) 666-1101
 Website: www.allemajor.com

TRADERS VILLAGE
 2800 W. 10th St.
 OVERLAND PARK, KS 66211

NO.	DATE	DESCRIPTION
1	10/15/03	ISSUED FOR PERMIT
2	10/15/03	ISSUED FOR PERMIT
3	10/15/03	ISSUED FOR PERMIT
4	10/15/03	ISSUED FOR PERMIT
5	10/15/03	ISSUED FOR PERMIT

DATE ISSUED FOR PERMIT
10/15/03

Questions contact – Sibhita Mahabier 781-258-9169

Petition of the Massachusetts Electric Company d/b/a National Grid
Of NORTH ANDOVER, MASSACHUSETTS
For Electric conduit Location:

To City Council of Salem, Massachusetts

Respectfully represents the Massachusetts Electric Company d/b/a National Grid of North Andover, Massachusetts, that it desires to construct a line of underground electric conduits, including the necessary sustaining and protecting fixtures, under and across the public way or ways hereinafter named.

Wherefore it prays that after due notice and hearing as provided by law, it be granted permission to excavate the public highways and to run and maintain underground electric conduits, together with such sustaining and protecting fixtures as it may find necessary for the transmission of electricity, said underground conduits to be located substantially in accordance with the plan filed herewith marked: First St - Salem - Massachusetts.

The following are the streets and highways referred to:

Plan # 30334560 First St - National Grid to install beginning at a point approximately 295 +/- feet east/northeast of the centerline of the intersection of First St and Trader's Way and continuing approximately 55 +/- feet in a northerly direction. Installing 55' +/- of 4-5" PVC conduits encased in concrete and all appurtenances from existing MH 1 to the property line of 45 Trader's Way.

Location approximately as shown on plan attached

Massachusetts Electric Company d/b/a National Grid
BY Robert Coulter
Engineering Department

Dated: April 23, 2021

Salem

ORDERED:

Notice having been given and public hearing held, as provided by law, that the Massachusetts Electric Company d/b/a National Grid be and it is hereby granted permission to excavate the public highways and to run and maintain underground electric conduits, together with such sustaining and protecting fixtures as said company may deem necessary, in the public way or ways hereinafter referred to, and to make the necessary house connections along said extensions, as requested in petition with said company dated the 23rd day of April, 2021.

Said underground electric conduits shall be located substantially in accordance with the plan filed herewith marked – First St - Salem - Massachusetts. Plan # 30334560.

The following are the public ways or part of ways along which the underground electric conduits above referred to may be laid:

First St - National Grid to install beginning at a point approximately 295+/- feet east/northeast of the centerline of the intersection of First St and Trader's Way and continuing approximately 55+/- feet in a northerly direction. Installing 55' +/- of 4-5" PVC conduits encased in concrete and all appurtenances from existing MH 1 to the property line of 45 Trader's Way.

I hereby certify that the foregoing order was adopted at a meeting of the
.....
....., held on the day of, 20
....., 20

Received and entered in the records of location orders of the City/Town of
Book Page

Attest:
.....

..... hereby certify that on20....., at o'clock,M
at, a public hearing was held on the petition of
Massachusetts Electric Company d/b/a National Grid for permission to construct the underground
electric conduits described in the order herewith recorded, and that I mailed at least seven days
before said hearing a written notice of the time and place of said hearing to each of the owners of
real estate (as determined by the last preceding assessment for taxation) along the ways or parts of
ways upon which the Company is permitted to construct the underground electric conduits under
said order. And that thereupon said order was duly adopted.

.....
.....



45 Trader's Way
Salem, MA 01970

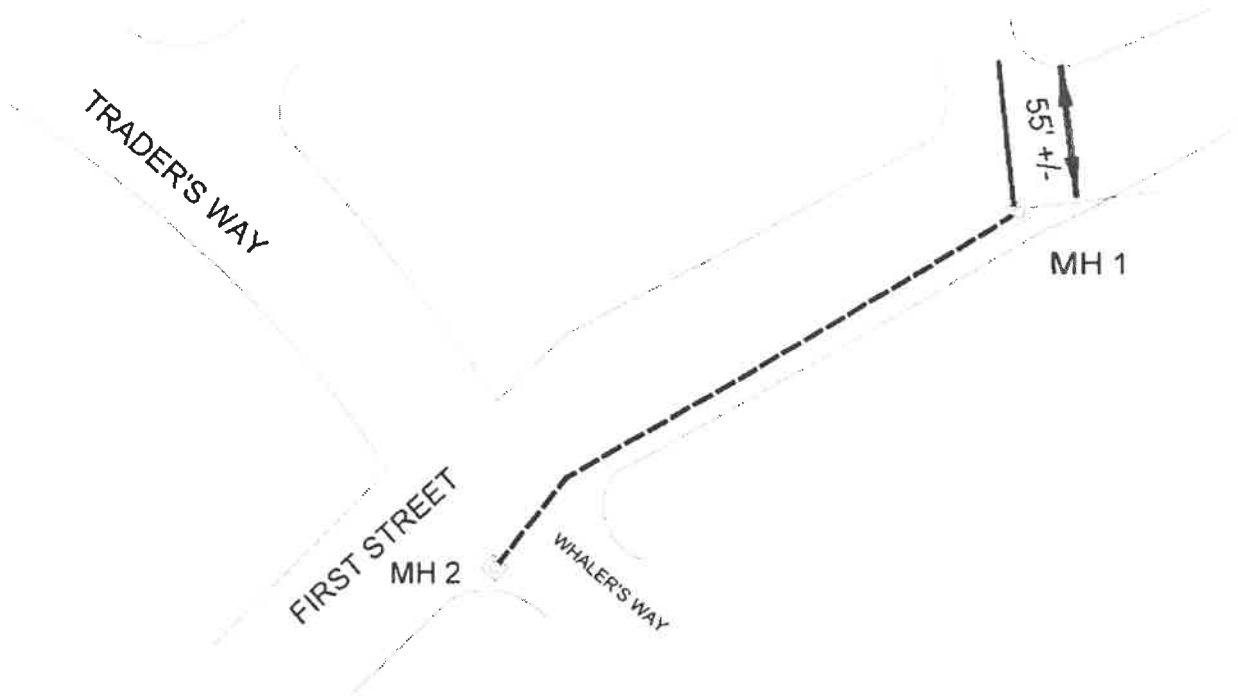

UNDERGROUND PETITION

nationalgrid



Manhole (EXISTING)



PROPOSED CONDUIT 4-5"



EXISTING CONDUIT 8-5"

Proposal to Install 4-5" PVC Conduits Encased in Concrete and All Appurtenances from Existing MH 1 to the Property of 45 Trader's Way, Salem, MA 01970.

Date: 04-07-2021

WORK REQUEST: 12-21-30334560

To The: City Of Salem

For Proposed: 4-5" Conduits Encased in Concrete Location: First Street

Drawn By: Sibhita Mahabier-Sheehy

DISTANCES ARE APPROXIMATE



CITY OF SALEM, MASSACHUSETTS

Kimberley Driscoll
Mayor

Office of the Mayor

May 27, 2021

Honorable Salem City Council
Salem City Hall
Salem, Massachusetts 01970

Ladies and Gentlemen of the City Council:

I am pleased to appoint Emiluis Perez of 7 Ord Street #2 to the Salem Parks and Recreation Commission. Mr. Perez will complete the remainder of a five-year term previously held by Mr. Chris Burke and which expires on October 18, 2023. Please also join me in thanking Mr. Burke for his 14 years of dedicated service to our community as a member of the Commission.

Mr. Perez currently serves as legislative aide to State Representative Paul Tucker. Prior to his work at the State House, he was the Teen Director and Athletics Director for the Boys and Girls Club of Greater Salem and, previous to that, was a residential counseling intern at Plummer Youth Promise. Mr. Perez has extensive experience in recreational and youth programming, events, and operations. He holds a Bachelor's degree in social work from Salem State University.

I strongly recommend confirmation of Mr. Perez's appointment to the Parks and Recreation Commission. We are fortunate that he is willing to serve our community in this important role and lend his dedication and expertise to the Commission and its work.

Sincerely,

Kimberley Driscoll
Mayor
City of Salem



CITY OF SALEM, MASSACHUSETTS

Kimberley Driscoll
Mayor

May 27, 2021

To the City Council
City Hall
Salem, Massachusetts

Ladies and Gentlemen of the Council:

I appoint Steven R. Havey of 117 Dolloff Avenue Beverly, MA 01915 to serve as a Constable in the City of Salem for a term to expire April 18, 2024.

Very truly yours,

A handwritten signature in black ink, appearing to read "Kim Driscoll", written in a cursive style.

Kimberley Driscoll
Mayor



CITY OF SALEM, MASSACHUSETTS

Kimberley Driscoll
Mayor

May 27, 2021

Honorable Salem City Council
Salem City Hall
Salem, MA 01970

RE: FY2022 Budget Filing

Ladies and Gentlemen of the Council:

We are pleased to present the balanced FY2022 operating and capital budgets for the City of Salem and the Salem Public Schools. The complete budget binders will be provided to you on Thursday.

The COVID-19 pandemic has impacted our community, our Commonwealth, and our country to an unprecedented degree. The virus has taken lives, disrupted work and school, and forced us to adapt to ensure the health and safety of our community. Through it all, our dedicated City workforce has continued to provide the critical government services upon which our constituents rely every day. The pandemic, however, also triggered an unforeseeable financial crisis. With economic activity coming to a near complete standstill for much of FY2021, City revenues were substantially impacted. Now, however, our revenues are rebounding, and our local economy is coming back stronger than ever. Over the past year Salem had a net zero loss in businesses and our storefront vacancy rate decreased to 4%. Three of every five residents who lost their job at the height of the pandemic recession are now working again and the pace of our drop in unemployment is double that of the nationwide pace. We weathered the fiscal challenges without having to draw down substantially from our reserve funds or tap heavily into our levy capacity.

In FY2022 we will continue to strive to exceed the service level expectations of our constituents, while ensuring fiscal prudence in expenditures. The proposed budget aligns operations with our strategic goals and objectives, while maintaining necessary fiscal controls and a careful attention to our financial forecasts. It will demonstrate, once again, a strong commitment to the people we are fortunate enough to have been elected to serve. It continues our balanced and responsible approach to City finances. It invests in the critical services that make Salem a vibrant city and one with schools in which we can all take pride – in short, a stronger, more livable city for all. I look forward to working with you in the coming days to enact this proposed spending plan to ensure that Salem is a City that continues to welcome and work for everyone.

Sincerely,

Kimberley Driscoll
Mayor
City of Salem



CITY OF SALEM

In City Council,

May 27, 2021

Ordered:

Fiscal Year 2022 General Fund Capital Improvement Program Funded from Bond Authorization as amended below:

That the sum of \$9,819,000 be and hereby is appropriated to pay costs of the following capital equipment and capital improvement projects listed under the heading FY22 CIP- Funded from BOND AUTHORIZATION and for the payment of all costs incidental and related thereto, and that to meet said appropriation the Treasurer, with the approval of the Mayor, is authorized to borrow said sum under M.G.L. Chapter 44, Section 7, or pursuant to any other enabling authority, and to issue bonds or notes of the City therefor.

FY22 CIP-Funded from BOND AUTHORIZATION		
Engineering	Roads, Sidewalks & Crosswalks (Non Chapter 90 eligible, includes Bridge, Boston, Washington, Essex, Other)	\$ 1,500,000
Engineering	Citywide Seawall Improvements	\$ 200,000
Engineering	McGrath Park Soils Redemption	\$ 200,000
Engineering	Derby Street Complete Project Phase 3	\$ 560,000
Fire	New Engine to Replace Engine 1	\$ 662,000
IT	Annual Equipment-Life-Cycle Mgmt Program (City)	\$ 125,000
Library	General Building Upgrades, Improvements, Envelope, ADA	\$ 85,000
Recreation	Golf Course Cart Paths (CPA)	\$ 426,000
Recreation	City Wide Playgorund Equipmen, Court, Minor Park Repairs	\$ 100,000
Recreation	Park and Recreation Major Improvements/ADA	\$ 100,000
Recreation	Willows Pier	\$ 900,000
Parking and Traffic	Traffic Calming Improvements	\$ 70,000
Parking and Traffic	Bicycle Infrastructure Design, Implementation & Repairs/Improvements	\$ 100,000
Parking and Traffic	Museum Place Garage Renovation Phase 2	\$ 1,580,000
Parking and Traffic	South Harbor Garage Stair Replacement & ADA Compliance	\$ 850,000
Parking and Traffic	MP & SH Garage Maintenance, Repairs, ADA	\$ 100,000
Planning	OTH Restorations & Systems Assesment, Planning, Design	\$ 100,000
Police	Police & Fire Radio Communication System	\$ 250,000
Police	Vehicle Replacement Program	\$ 150,000
Public Servcies - Equipment	Annual Small Repairs, DPS Building Studies and ADA Improvements - DPS & Cemeteries	\$ 75,000
Public Servcies - Equipment	Salem DPS Salt Shed Project	\$ 420,000
Public Servcies - Equipment	Replace Primary Sweeper	\$ 241,000

Schools	School Life Safety, MEP, Utility, Roof Repairs, Upgrades, Studies		\$ 150,000
Schools	Collins Roof/Masonry Study/Repair		\$ 125,000
Schools	District Camera and Access Control		\$ 250,000
Schools	Energy/Water Upgrades and Audits		\$ 125,000
Schools	Witchcraft Heights Floor Replacement		\$ 300,000
Schools	ADA/Architectural/Interior, Site Repairs, Upgrades, Studies		\$ 75,000
	Schools		
TOTAL BOND AUTHORIZATION:			\$ 9,819,000

Any premium received upon the sale of any bonds or notes approved by this vote, less any such premium applied to the payment of the costs of issuance of such bonds or notes, may be applied to the payment of costs approved by this vote in accordance with Chapter 44, Section 20 of the General Laws, thereby reducing the amount authorized to be borrowed to pay such costs by a like amount.

Be it further **Ordered**:

That the Mayor and the Treasurer are each authorized to file an application to qualify under Chapter 44A of the Massachusetts General Laws any and all bonds of the City issued under and pursuant hereto, and to provide such information and execute such documents as may be required in connection therewith.



CITY OF SALEM, MASSACHUSETTS

Kimberley Driscoll
Mayor

Office of the Mayor

May 27, 2021

Salem City Council
City Hall
93 Washington Street
Salem, MA 01970

Ladies and Gentlemen of the City Council:

Enclosed please find supporting Orders and Ordinances necessary for the adoption of the FY2022 City budget. These items include:

1. Council Order authorizing the revolving funds.
2. Council Order appropriating from short-term capital.
3. Bond Order for general fund capital.
4. Bond Order for water and sewer capital.
5. Ordinance for water rate.
6. Ordinance for sewer rate.

I recommend adoption of the enclosed Orders and Ordinances as part of the FY2022 budget process and welcome any questions you may have regarding them during our regular budget hearings.

Sincerely,

Kimberley Driscoll

Kimberley Driscoll
Mayor
City of Salem



CITY OF SALEM

In City Council,

May 27, 2021

Ordered:

Fiscal Year 2022 Water and Sewer Capital Improvement Program Funded from Bond Authorization as amended below:

That the sum of \$4,429,000 be and hereby is appropriated to pay costs of the following capital equipment and capital improvement projects listed under the heading FY22 CIP – Funded from BOND AUTHORIZATION and for the payment of all costs incidental and related there to, and that to meet said appropriation the Treasurer, with the approval of the Mayor, is authorized to borrow said sum under M.G.L. Chapter 44, Sections 7 and/or 8, or pursuant to any other enabling authority, and to issue bonds or notes of the City therefor.

FY22 CIP-Funded from BOND AUTHORIZATION			
Water	Citywide Flushing, valve excecise, leak detection, GIS		\$ 400,000.00
Water	Folly Hill Water Tank Upgrades/Major Repairs		\$ 345,000.00
Water	Highland Ave 16 inch Water Main		\$ 300,000.00
Water	Water Distribution Main System Improvements		\$ 800,000.00
Water	Water Meter Reader Truck		\$ 34,000.00
Water	Water Transmission Main System Improvements		\$ 400,000.00
Water	Loring Ave. 16 Ince Water Main Replacement		\$ 200,000.00
Sewer	Community Wide Climate Change/Stormwater/Watershed Model and Outreach		\$ 50,000.00
Sewer	Citywide Drain & Sewer Flushing, Pipe Replacements, Sewer Extensions, GIS		\$1,450,000.00
Sewer	Ocean Ave Sewer Pump Station Design		\$ 150,000.00
Sewer	SSES Report Implementation (eliminate I/I sources citywide)		\$ 300,000.00
TOTAL BOND AUTHORIZATION:			\$ 4,429,000

Any premium received upon the sale of any bonds or notes approved by this vote, less any such premium applied to the payment of the costs of issuance of such bonds or notes, may be applied to the payment of costs approved by this vote in accordance with Chapter 44, Section 20 of the General Laws, thereby reducing the amount authorized to be borrowed to pay such costs by a like amount.

Be it further **Ordered**:

That the Mayor and the Treasurer are each authorized to file an application to qualify under Chapter 44A of the Massachusetts General Laws any and all bonds of the City issued under and pursuant hereto, and to provide such information and execute such documents as may be required in connection therewith.



CITY OF SALEM, MASSACHUSETTS

Kimberley Driscoll
Mayor

Office of the Mayor

May 27, 2021

Salem City Council
City Hall
93 Washington Street
Salem, MA 01970

Ladies and Gentlemen of the City Council:

Enclosed please find supporting Orders and Ordinances necessary for the adoption of the FY2022 City budget. These items include:

1. Council Order authorizing the revolving funds.
2. Council Order appropriating from short-term capital.
3. Bond Order for general fund capital.
4. Bond Order for water and sewer capital.
5. Ordinance for water rate.
6. Ordinance for sewer rate.

I recommend adoption of the enclosed Orders and Ordinances as part of the FY2022 budget process and welcome any questions you may have regarding them during our regular budget hearings.

Sincerely,

Kimberley Driscoll

Kimberley Driscoll
Mayor
City of Salem



CITY OF SALEM

In City Council,

May 27, 2021

Ordered:

Ordered:

That the sum of \$995,000 be and hereby is appropriated as part of the FY 2022 Capital Improvement Plan to be expended as listed below in accordance with the recommendation of Her Honor the Mayor.

Department	Description	Account	Amount
Building	Improvements, Upgrades, Repairs, and ADA Compliance -	2000-20002022AA	\$ 40,000
City Clerk	Replcacement of Voting Equipment	2000-20002203AA	\$ 55,000
Electrical	F350 Utility Truck	2000-20002208AA	\$ 55,000
Fire	Portable Radios	2000-20002210AA	\$ 20,000
Fire	General Building Maintenance/Upgrades/Master Plan	2000-20002210AB	\$ 50,000
HarborMaster	Dockhouse Relocation	2000-20002211AA	\$ 50,000
Health	Mack Park Community Farm	2000-20002212AA	\$ 15,000
Recreation	Equipment - Golf Course & Winter Island	2000-20002217AA	\$ 87,000
Parking	Parking Equipment Install and Maintenance (meters, kiosks, Evs, other)	2000-20002218AA	\$ 75,000
Planning	Studies, Including Open Space, Harmony Grove Multi-Use Path, Other	2000-20002220AA	\$ 100,000
Planning	Dickson Chapel Next Phases Design	2000-20002220AB	\$ 30,000
Planning	OTH & Artist Row General Upgrades, Improvements, Repairs, & ADA	2000-20002220BB	\$ 30,000
Police	Body Worn Cameras, Police Equipment	2000-20002221AA	\$ 90,000
Police	Community Cameras	2000-20002221AB	\$ 45,000

Police	Police Headquarters General Repairs, Improvements, Elevator, ADA	2000- 20002221AC	\$ 75,000
Public Services	F550 Dump	2000- 20002223AA	\$ 69,000
School	Motorized Cleaning Equipment	2000- 20002225AA	\$ 109,000
TOTAL CAPITAL OUTLAY FUND			\$ 995,000



CITY OF SALEM, MASSACHUSETTS

Kimberley Driscoll
Mayor

Office of the Mayor

May 27, 2021

Salem City Council
City Hall
93 Washington Street
Salem, MA 01970

Ladies and Gentlemen of the City Council:

Enclosed please find supporting Orders and Ordinances necessary for the adoption of the FY2022 City budget. These items include:

1. Council Order authorizing the revolving funds.
2. Council Order appropriating from short-term capital.
3. Bond Order for general fund capital.
4. Bond Order for water and sewer capital.
5. Ordinance for water rate.
6. Ordinance for sewer rate.

I recommend adoption of the enclosed Orders and Ordinances as part of the FY2022 budget process and welcome any questions you may have regarding them during our regular budget hearings.

Sincerely,

Kimberley Driscoll
Mayor
City of Salem



CITY OF SALEM

In City Council,

Ordered:

May 27, 2021

DOR requires that CO#71 that was approved February 25, 2021 be reapproved and modified.

That the sum of Eight Hundred and Ninety Thousand dollars (\$890,000.00) is hereby appropriated from the "Fund Balance Reserved for Appropriation - Free Cash" account (1-3245) to the to the "Engineering FY2021 Water Highland CIP" account (3050-3050300) for the improvement of approximately 1,800 feet of a 16-inch water main in Highland Avenue, in accordance with the recommendation of Her Honor the Mayor.

Account	Description	Amount
3050-3050300	FY2021 Water Highland CIP	\$890,000.00
Total		\$ 890,000.00



City of Salem, Massachusetts

Finance Department
93 Washington Street
Salem, MA 01970
www.salem.com

Kimberley L. Driscoll, Mayor

Anna Freedman, Finance Director

May 27, 2021

Honorable Salem Mayor Kimberley Driscoll
Salem City Hall
Salem, Massachusetts

Dear Honorable Mayor Driscoll:

Enclosed herewith is a request to re-approve a transfer previously ordered from Retained Earnings – Water/Sewer Fund that was authorized in February 2021. The Department of Revenue (DOR-DLS) has informed us that the previous order must be re-approved and modified due to the timing of Retained Earnings and Free Cash certification for fiscal year 2020, and the current certified balance of Retained Earnings. The money originally ordered to be transferred from Retained Earnings must be modified to be transferred from Free Cash.

Please let me know if you would like to discuss further.

Regards,

A handwritten signature in black ink, appearing to read "A. Freedman".

Anna Freedman
Finance Director

Enclosures



CITY OF SALEM

In City Council,

Ordered:

May 27, 2021

DOR requires that CO#10 that was approved January 14, 2021 be reapproved.

Original Request: That the sum of Twenty Thousand Dollars (\$20,000.00) is hereby appropriated from the "Fund Balance Reserved for Appropriation – Free Cash" account (1-3245) to the "Health Department Contracted Services" account (15102-5320) to fund labor and equipment rental costs for the Mack Park Food Farm in accordance with the recommendation of Her Honor the Mayor.

Account	Description	Amount
15102-5320	Health Department Contracted Services	\$20,000.00
Total		\$ 20,000.00



CITY OF SALEM

In City Council,

May 27, 2021

Ordered:

DOR requires that CO#12 that was approved January 14, 2021 be reapproved.

Original request: That the sum of Seven Thousand Dollars (\$7,000.00) is hereby appropriated from the "Fund Balance Reserved for Appropriation - Free Cash" account (1-3245) to the "COA Vehicle Prts & Acces" account (15412-5483) for state inspections and maintenance and repairs in accordance with the recommendation of Her Honor the Mayor.

Account	Description	Amount
15412-5483	COA Vehicle Prts & Acces	\$7,000.00
Total		\$ 7,000.00



CITY OF SALEM

In City Council,

May 27, 2021

Ordered:

DOR requires that CO#33 that was approved January 28, 2021 be reapproved.

Original request: That the sum of Three Hundred and Fifty Thousand Dollars (\$350,000.00) is hereby appropriated from General Fund Balance Reserved for Free Cash (1-3245) to the following special revenue funds. This transfer is requested in accordance with the recommendation of Her Honor the Mayor.

Fund Name/Description	Amount
Retirement Stabilization Fund 8311	\$ 350,000.00



CITY OF SALEM

In City Council,

May 27, 2021

Ordered:

DOR requires that CO#66 that was approved February 11, 2021 be reapproved.

Original request: That the sum of Eighty-Three Thousand, Seven Hundred, Fourteen Dollars and Twenty-Eight Cents (\$83,714.28) is hereby appropriated from the "Fund Balance Reserved for Appropriation – Free Cash" account (1-3245) to restore budget cuts made as a result of COVID 19 Pandemic in accordance with the recommendation of Her Honor the Mayor.

Account	Description	Amount
14111-5111	DPS FT Salaries	83,714.28
Total		\$ 83,714.28



CITY OF SALEM

In City Council,

Ordered:

May 27, 2021

DOR requires that CO#135 that was approved March 25, 2021 be reapproved.

Original request: That the sum of Three Hundred Thousand Dollars (\$350,000.00) is hereby appropriated from General Fund Balance Reserved for Free Cash (1-3245) to the following special revenue funds. This transfer is requested in accordance with the recommendation of Her Honor the Mayor.

Fund Name/Description	Amount
Retirement Stabilization Fund 8311	\$ 350,000.00



CITY OF SALEM

In City Council,

May 27, 2021

Ordered:

DOR requires that CO#141 that was approved March 25, 2021 be reapproved.

Original request: That the sum of Forty Thousand Dollars (\$40,000.00) is hereby appropriated from the "Fund Balance Reserved for Appropriation – Free Cash" account (1-3245) to appropriate start up costs for the Parks & Recreation Department, New Charter Street Cemetery Welcome Center at the Samuel Pickman House as provided below in accordance with the recommendation of Her Honor the Mayor.

Account	Description	Amount
16521-5118	P&R Seasonal Salary	\$ 24,000.00
16522-5581	P&R Inventory	14,000.00
16522-5320	P&R Contracted Services	2,000.00
Total		\$ 40,000.00



CITY OF SALEM

In City Council,

May 27, 2021

Ordered:

DOR requires that CO#199 that was approved April 22, 2021 be reapproved.

Original request: That the sum of Thirty Thousand Dollars (\$30,000.00) is hereby appropriated from the "Fund Balance Reserved for Appropriation – Free Cash" account (1-3245) to the Planning Contracted Services account to update the local wetlands protection policy in accordance with the recommendation of Her Honor the Mayor.

Account	Description	Amount
11822-5320	Contracted Services	\$ 30,000.00
Total		\$ 30,000.00



CITY OF SALEM

In City Council,

May 27, 2021

Ordered:

DOR requires that CO#201 that was approved April 22, 2021 be reapproved.

Original request: That the sum of Twenty-Three Thousand Two-hundred Dollars (\$23,200.00) is hereby appropriated from the "Fund Balance Reserved for Appropriation – Free Cash" account (1-3245) to increase the Police Department Training and Education Account to cover the cost recruit training in accordance with the recommendation of Her Honor the Mayor.

Account	Description	Amount
12102-5317	Training and Education	\$ 23,200.00
	Total	\$ 23,200.00



CITY OF SALEM

In City Council,

May 27, 2021

Ordered:

DOR requires that CO#202 that was approved April 22, 2021 be reapproved.

Original request: That the sum of Twenty Thousand Dollars (\$20,000.00) is hereby appropriated from the "Fund Balance Reserved for Appropriation – Free Cash" account (1-3245) to replenish the Fire Department purchase of services account to upgrade VOC voice-alarm dispatch system. in accordance with the recommendation of Her Honor the Mayor.

Account	Description	Amount
12202-5300	Purchase of Services	\$ 20,000.00
Total		\$ 20,000.00



CITY OF SALEM, MASSACHUSETTS

Kimberley Driscoll
Mayor

Office of the Mayor

May 27, 2021

Honorable Salem City Council
Salem City Hall
Salem, MA 01970

Ladies and Gentlemen of the Council:

Enclosed please find a housekeeping request from the Department of Revenue to re-approve previously voted transfers from FY2020 Free Cash. These requests are necessary due to the timing of Free Cash certification from the prior fiscal year.

I recommend adoption of the enclosed Orders and invite you to contact Finance Director Anna Freedman with any questions that you may have regarding them.

Sincerely,

Kimberley Driscoll
Mayor
City of Salem



City of Salem, Massachusetts

Finance Department
93 Washington Street
Salem, MA 01970
www.salem.com

Kimberley L. Driscoll, Mayor

Anna Freedman, Finance Director

May 27, 2021

Honorable Salem Mayor Kimberley Driscoll
Salem City Hall
Salem, Massachusetts

Dear Honorable Mayor Driscoll:

Enclosed herewith are nine requests to re-approve transfers from Free Cash that were previously authorized from January 2020 to date. The Department of Revenue (DOR-DLS) has informed us that the previous orders must be re-approved due to the timing of Free Cash certification for fiscal year 2020.

Please let me know if you would like to discuss further.

Regards,

A handwritten signature in blue ink, appearing to read "Anna Freedman".

Anna Freedman
Finance Director

Enclosures



CITY OF SALEM

In City Council,

Ordered:

May 27, 2021

That the sum of Fifteen Thousand Dollars (\$15,000.00) is hereby appropriated from the "Fund Balance Reserved for Appropriation – Free Cash" account (1-3245) to replenish the City Council Advertising account for required public meeting advertising expenditures in accordance with the recommendation of Her Honor the Mayor.

Account	Description	Amount
11112-5306	City Council Advertising	\$ 15,000.00
Total		\$ 15,000.00



CITY OF SALEM, MASSACHUSETTS
Kimberley Driscoll
Mayor

May 27, 2021

To the City Council
City Hall
Salem, Massachusetts

Ladies and Gentlemen of the Council:

Enclosed herewith is a request to transfer Fifteen Thousand Dollars (\$15,000.00) from the Fund Balance Reserved for Appropriation – Free Cash account (1-3245).

This request is necessary to cover the costs associated with the City Clerk's advertising account for the remainder of the fiscal year.

I recommend passage of this accompanying order.

Sincerely,

A handwritten signature in black ink that reads "Kim Driscoll".

Kimberley Driscoll
Mayor

City of Salem, Massachusetts
Office of the City Clerk

Ilene Simons
City Clerk



Room 1
City Hall

May 17, 2021

The Honorable Kimberley Driscoll
Mayor of Salem
City Hall
Salem, MA 01970

Dear Mayor Driscoll:

I respectfully request an appropriation in the amount of \$15,000.00 to the "City Council Advertising" Account (11112-5306). It is my hope that this amount will be adequate to fund the advertising account for the remainder of the fiscal year.

As you know, the Salem City Charter, as well as Massachusetts General Laws, requires that all Ordinances, Bond Orders, and certain public hearings for various issues, including zoning, and setting the tax rate be advertised in a newspaper of general circulation within the city. This account has already been virtually depleted.

The current balance in this account is \$3,624.45. The bill I will be receiving for the month of April will be \$5,292.58. In addition, other advertisements that will be coming up for the month of May and June will be the second passage of the ADU (1st passage cost \$4,000), first and second passages of the Bond Orders for the General CIP and Water/Sewer CIP for FY2022, as well as possibly the Short-term rental ordinance, the amended resident sticker ordinance and demolition delay ordinance to name a few.

Thank you for your consideration.

Very truly yours,

ILENE SIMONS
CITY CLERK

**CITY OF SALEM – Finance Department
Free Cash, W & S R/E, R/Res & Budget Transfer Request Form**

From: City Council
Department

Nore Simons
Department Head Authorizing Signature

5/17/2021
Date

Budget or R/Res

Transfers To: _____ Desc: _____ Budget Amt: _____
(Org/Object) Balance: _____

From: _____ Desc: _____ Balance: _____
(*Note - Please include letter to Mayor for Transfers from different Personnel & Non-personnel lines)

Current Balance in Receipts Reserved Fund Above (if applicable) - \$ _____ Date: _____

Free Cash or Retained Earnings (W/S) To: 1112-5306 Desc: Advertising
(Org/Object)

Budget Amt: 27,500.00
Balance: 3,624.45

Raise & Appropriate
Please circle one

Amount Requested: \$ 15,000.00

Reason (Be Specific) to cover remaining advertising costs for FY2021. Upcoming April bill is \$292.58. Upcoming May + June bills to include second passage of ADU (\$4,000), 1st + 2nd Passage of FY22 CIP General + W&S Bonds, Fire Ordinance, & others in committee Resident shield, Demolition by, traffic ordinances etc.

For Finance Department and Mayor's Use Only:

- Budget Transfer Mayor Approval City Council Approval
- Free Cash Appropriation – City Council Approval – Gen Fund \$ _____
Free Cash Balance
- R/E Appropriation – Water \$ _____ R/E Balance R/E Appropriation Sewer \$ _____
R/E Balance
- Receipts Reserve – City Council Approval \$ _____
R/Res Fund Balance
- Raise & Appropriate Other _____

Recommendation: Approved Denied _____
Finance Director

Completed: Date: _____ By: _____ CO # _____ JE#: _____ Transfer #: _____



CITY OF SALEM

In City Council,

May 27, 2021

Ordered:

That the sum of Ten Thousand Dollars (\$10,000.00) is hereby appropriated from the "Fund Balance Reserved for Appropriation – Free Cash" account (1-3245) to replenish the Police Department radio / vehicle account for increased costs of parts and repairs in accordance with the recommendation of Her Honor the Mayor.

Account	Description	Amount
12102-5253	Radio/Vehicle	\$ 10,000.00
	Total	\$ 10,000.00



CITY OF SALEM, MASSACHUSETTS

Kimberley Driscoll
Mayor

May 27, 2021

To the City Council
City Hall
Salem, Massachusetts

Ladies and Gentlemen of the Council:

Enclosed herewith is a request to transfer Ten Thousand Dollars (\$10,000.00) from the Fund Balance Reserved for Appropriation – Free Cash account (1-3245).

This request is necessary to cover the costs associated with the Police Departments radio/vehicle account for increased costs of parts and repairs.

I recommend passage of this accompanying order.

Sincerely,

A handwritten signature in black ink that reads "Kim Driscoll".

Kimberley Driscoll
Mayor



CHIEF OF POLICE
LUCAS J. MILLER

City of Salem, Massachusetts

Police Department Headquarters

95 Margin Street

Salem, Massachusetts 01970

(978) 744-2204

04 May 2021

Mayor Kimberley Driscoll
Salem City Hall
93 Washington Street
Salem, Massachusetts 01970

Dear Mayor Driscoll,

I am writing to request a Free Cash transfer in the amount of \$10,000.00 to the Department's Radio / Vehicle (12102-5253) budget line item. Justification for this fund transfer request is set forth herein.

The Department maintains a fleet of over 50 vehicles, all of which require some degree of maintenance and/or repair. Several frontline cruisers have required extensive repairs to keep them in a safe and operable condition. Parts and repair costs have increased and, as you are aware, the Department of Public Services has outsourced some cruiser repair work to local dealerships due to workload and personnel shortages, leading to an increase in expenses.

Based on an analysis of past monthly expenditures, I am requesting a Free Cash transfer of \$10,000.00 to cover vehicle and radio repair, maintenance, parts and services to see the Department through the end of the fiscal year. The City's Finance Department Free Cash Budget Transfer Request form is attached.

Thank you for your consideration. I am available to discuss this request at your convenience.

Sincerely,

Lucas J. Miller
Chief of Police

Encl

CITY OF SALEM - Finance Department
Free Cash, W & S R/E, R/Res & Budget Transfer Requiring Council Approval

From: 210 Police Department Lucas J. Miller, Chief of Police May 4, 2021
Department Department Head Authorizing Signature Date

Budget or R/Res
Transfers To: _____ Desc: _____ Budget Amt: _____
(Org/Object) Curr Balance: _____
 From: _____ Desc: _____ Budget Amt: _____
(*Note - Please include letter to Mayor for Transfers from different Personnel & Non-personnel lines) Curr Balance: _____
 Current Balance in Receipts Reserved Fund Above (if applicable) - \$ _____ Date: _____

Free Cash or Retained Earnings (W/S) To: 12102-5253 Desc: Radio/Vehicle Budget Amt: \$78,778.00
Please circle one (Org/Object) Curr Balance: \$63.54

Amount Requested: \$ \$10,000.00

Reason (Be Specific) To cover vehicle repairs/maintenance for a fleet of over 50 vehicles for the months of May and June 2021. The cost of repairs have increased due to the fact that we are now sending our vehicles for some repairs to local dealerships due to short staffing at the Motor Pool.

For Finance Department Use Only:

_____ Budget Transfer _____ Mayor Approval _____ City Council Approval
 _____ Free Cash Appropriation - City Council Approval - Gen Fund \$ _____
Free Cash Balance
 _____ R/E Appropriation - Water \$ _____ R/E Appropriation Sewer \$ _____
R/E Balance R/E Balance
 _____ Receipts Reserve - City Council Approval \$ _____
R/Res Fund Balance
 _____ Raise & Appropriate _____ Other _____

Recommendation: Approved Denied

Finance Director

Mayor

Completed: Date: _____ By: _____ CO # _____ JE# _____ Transfer #: _____



CITY OF SALEM

In City Council,

May 27, 2021

Ordered:

That the sum of Four Thousand Dollars (\$4,000.00) is hereby appropriated from the "Fund Balance Reserved for Appropriation - Free Cash" account (1-3245) to the "Parks and Recreation Renovation and Repairs" account (16502-5846) for signage for the Community Life Center in accordance with the recommendation of Her Honor the Mayor.

Account	Description	Amount
16502-5846	Parks and Recreation Renovation and Repairs	\$4,000.00
Total		\$ 4,000.00



CITY OF SALEM, MASSACHUSETTS

Kimberley Driscoll
Mayor

Office of the Mayor

May 27, 2021

Honorable Salem City Council
Salem City Hall
Salem, MA 01970

Ladies and Gentlemen of the Council:

Enclosed please find a request to appropriate \$4,000 from Fund Balance Reserved for Appropriation – Free Cash (1-3245) to the Parks and Recreation Renovation and Repairs account (16502-5846) to fund the fabrication and installation of additional signage at the driveway to the Mayor Jean Levesque Community Life Center. I recommend adoption of the enclosed Order and invite you to contact COA Director Terry Arnold with any questions that you may have regarding it.

Sincerely,

Kimberley Driscoll
Mayor
City of Salem



CITY OF SALEM, MASSACHUSETTS
PARKS, RECREATION & COMMUNITY SERVICES
401 BRIDGE ST., SALEM, MA 01970
TEL: (978) 744-0180 OR (978) 744-0924
FAX (978) 744-7225
POBRIEN@SALEM.COM

KIMBERLEY DRISCOLL
MAYOR

PATRICIA O'BRIEN
DIRECTOR

April 26, 2021

Honorable Kimberley Driscoll
Mayor, City of Salem
93 Washington Street
Salem, MA 01970

Dear Mayor Driscoll,

I would like to request Free Cash funds in the amount of \$4,000.00 so that signage for the Community Life Center can be created and installed. If the amount is approved, it could please be deposited into the following fund.

Fund Name: Park and Recreation Renovation and Repairs

Fund Number: 100

Org/Object: 16502-5846

Additional signage is needed for the driveway entrance so that visitors and others find the building more easily.

Sincerely,

A handwritten signature in cursive script that reads "Teresa Gove Arnold".

Teresa Gove Arnold
Director, Salem Council on Aging

Cc: P. O'Brien



CITY OF SALEM

In City Council,

Ordered:

May 27, 2021

That the sum of Twelve Thousand, Five Hundred Twenty-Four Dollars and Fourteen Cents (\$12,524.14) be approved within the "Retirement Stabilization Fund-Vacation/Sick Leave Buyback" account (83113-5146) to be expended for the FY 2021 contractual buyback(s) listed below in accordance with the recommendation of Her Honor the Mayor.

Name	Department	Amount
Linda Serpa	Assistant Registrar	\$ 12,524.14
		\$ 12,524.14



CITY OF SALEM, MASSACHUSETTS

Kimberley Driscoll
Mayor

May 27, 2021

To the City Council
City Hall
Salem, Massachusetts

Ladies and Gentlemen of the Council:

Enclosed herewith is a request for an appropriation of Twelve Thousand, Five Hundred Twenty-Four Dollars and Fourteen Cents (\$12,524.14) appropriated in the "Retirement Stabilization Fund-Vacation Sick/leave buyback account (83113-5146) to fund the retirement buyback cost to be expended for FY 2021 contractual buyback.

Name	Department	Amount
Linda Serpa	Assistant Registrar	\$12,524.14

I recommend passage of the accompanying Order.

Very truly yours,

Kimberley Driscoll
Mayor



CITY OF SALEM, MASSACHUSETTS

HUMAN RESOURCES
120 WASHINGTON STREET
TEL. (978) 745-9595 EXT. 5630
FAX (978) 745-7298

KIMBERLEY DRISCOLL
MAYOR

LISA B. CAMMARATA
DIRECTOR OF HUMAN RESOURCES

MEMORANDUM

TO: Laurie Giardella, Director of Finance
DATE: May 5, 2021
RE: Retirement Stabilization Fund

Attached you will find a retirement buy back for a former employee of the City Clerks Office.

This former employee is entitled to the following amount of vacation and sick leave buyback.

Table with 2 columns: Description and Amount. Rows include Linda Serpa, 53.6632 vacation hours @ \$28.4534 per hour (\$1,526.90), 386.50 sick hours @ \$28.4534 per hour (\$10,997.24), and Total (\$12,524.14).

In accordance with the July 2008 Policy, I am requesting you verify the availability of the funds from the Retirement Stabilization Fund, prepare the Council Order, and continue the process in order that my staff can input the information in MUNIS and issue payments to this former employee upon Council approval.

Thank you for your cooperation, and if you should have any questions, please do not hesitate to contact me.

LBC [Handwritten signature]

CITY OF SALEM
APPROVAL-SICK DAYS/VACATION BUY-BACK

From: Department City Clerk

Date 4/27/2021

Authorized Signature: _____
Department Head/City or Business Manager/School

NAME: Linda Serpa

CALCULATION

VACATION HOURS # 53.6632 @ \$ 28,4534 = \$ 1,526.90

SICK HOURS # 386.50 @ \$ 28,4534 = \$ 10,991.24

PRO-RATED STIPENDS # _____ @ \$ _____ = \$ _____

OTHER # _____ @ \$ _____ = \$ _____

Total Amount Due: \$13,524.14
Please attach corresponding PAF or other backup to this sheet.

Reason: Retirement - 4/30/2021

For Human Resources's Use Only:

- VACATION HOURS
- SICK HOURS
- PER ACCRUAL REPORT
- OTHER

Org and Object: 83113 - 5146

Recommendation:

Approved

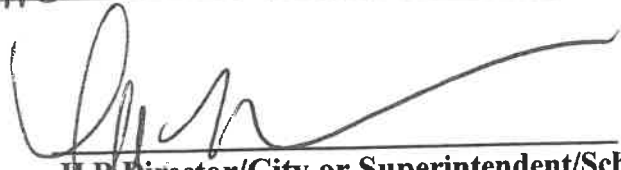

HR Director/City or Superintendent/Schools



CITY OF SALEM

THIS FORM CANNOT BE PROCESSED UNLESS ALL SHADED AREAS AND PERTINENT INFORMATION IS SUPPLIED
PERSONNEL ACTION / DATA FORM

DATE 5-5-21

NAME (LAST, FIRST, MIDDLE) <u>Serpa, Linda</u>		EMPLOYEE NO. <u>102233</u>	CHECK ALL THAT APPLY 1. EMPLOYMENT () 2. WAGE SALARY ADJUSTMENT () 3. TRANSFER () 4. LEAVE OF ABSENCE () 5. ADDRESS/NAME CHANGE () 6. TERMINATION () 7. OTHER ()
JOB TITLE <u>Asst. Registrar III</u>		JOB CODE	
DEPARTMENT <u>City Clerk</u>	DIVISION	DEPT. NO. <u>1030</u>	

1. EMPLOYMENT

ADDRESS-STREET	CITY	STATE	ZIP CODE	SOCIAL SECURITY NO.	NEW HIRE	REHIRE	RECALL	Salaried Hourly		
PERMANENT 1. Full Time 2. 20 HRS. + Part Time 3. Part Time	4. TEMP	CIVIL SERVICE YES NO	DATE APPROVED	VETERAN YES NO	SHIFT	PAY RATE \$	PER	SHIFT PREM.	Grade	Step
TELEPHONE NO.	DATE OF BIRTH	SEX M F	ETHNIC CODE	SCHEDULED HOURS	HOURLY RATE	# DEPENDENTS	MARITAL STATUS M S OTHER			
REQUIRED LICENSE:TYPE(S)			CLASS	EXPIRATION DATE						

2. WAGE / SALARY ADJUSTMENT (GIVE EXPLANATION IN SEC. 8)

ANNIVERSARY DATE	DATE OF LAST INCREASE	PRESENT RATE PER	PROPOSED RATE PER	NEW HOURLY RATE	GRADE	STEP	EFFECTIVE DATE
------------------	-----------------------	------------------	-------------------	-----------------	-------	------	----------------

3. TRANSFER-JOB, SHIFT, DEPT. (GIVE EXPLANATION IN SEC. 8)

NEW DEPT. & NO.	NEW JOB TITLE	NEW JOB CODE	RATE CHANGE:	YES	NO
NEW GRADE	NEW STEP	NEW PAY RATE PER	EFFECTIVE DATE	SHIFT CHANGE:	FROM TO

4. LEAVE OF ABSENCE (GIVE EXPLANATION IN SEC. 8)

FROM	TO	DATE RETURNED
------	----	---------------

5. ADDRESS / NAME CHANGE

NEW ADDRESS	STREET	CITY	STATE	ZIP CODE	NEW TELEPHONE NO.	CORRECT NAME TO
-------------	--------	------	-------	----------	-------------------	-----------------

6. TERMINATION (GIVE EXPLANATION IN SEC. 8)

LAST DAY WORKED	DATE HIRED	RECOMMENDED FOR REEMPLOYMENT	YES	NO
REASON RE-SIGNED LAID OFF END OF TEMP. RE-TIRED DIS-CHARGED	QUALITY OF WORK EXCEL GOOD FAIR POOR	ATTENDANCE EXCEL GOOD FAIR POOR	ATTITUDE EXCEL GOOD FAIR POOR	JOB KNOWLEDGE EXCEL GOOD FAIR POOR

7. EMERGENCY CONTACT

NAME:	TELEPHONE NO.	RELATIONSHIP
-------	---------------	--------------

8. EXPLANATION OF ACTION (or other action)
Retired eff 4/30/21

FINANCE DEPARTMENT	DATE
<u>None Simons</u>	<u>5-5-21</u>
DEPARTMENT HEAD / APPOINTING AUTHORITY	DATE
PERSONNEL DEPARTMENT	DATE
<u>[Signature]</u>	<u>5/5/2021</u>



CITY OF SALEM

In City Council, May 27, 2021

Ordered:

That the sum of Six Thousand, One Hundred Nineteen Dollars and Seventy-Six Cents (\$6,119.76) be approved within the "Retirement Stabilization Fund-Vacation/Sick Leave Buyback" account (83113-5146) to be expended for the FY 2021 contractual buyback listed below, in accordance with the recommendation of Her Honor the Mayor.

Name	Department	Amount
Deborah Jackson	Assessor	\$6,119.76



CITY OF SALEM, MASSACHUSETTS

Kimberley Driscoll
Mayor

May 27, 2021

To the City Council
City Hall
Salem, Massachusetts

Ladies and Gentlemen of the Council:

Enclosed herewith is a request for an appropriation of Six Thousand, One Hundred Nineteen Dollars and Seventy-Six Cents (\$6,119.76) appropriated within the "Retirement Stabilization Fund-Vacation/Sick Leave Buyback" account (83113-5146).

This transfer is necessary to fund the retirement buyback for Assessor employee.

Name	Department	Amount
Deborah Jackson	Assessor	\$6,119.76
	TOTAL:	\$6,119.76

I recommend passage of the accompanying Order.

Very truly yours,

A handwritten signature in black ink that reads "Kim Driscoll".

Kimberley Driscoll
Mayor

emailed 4/21/2021



CITY OF SALEM, MASSACHUSETTS

HUMAN RESOURCES
120 WASHINGTON STREET
TEL. (978) 745-9595 EXT. 5630
FAX (978) 745-7298

KIMBERLEY DRISCOLL
MAYOR

LISA B. CAMMARATA
DIRECTOR OF HUMAN RESOURCES

MEMORANDUM

TO: Laurie Giardella, Director of Finance
DATE: April 21, 2021
RE: Retirement Stabilization Fund

Attached you will find a retirement buy back for a former employee of the Assessors Department.

This former employee is entitled to the following amount of vacation buyback.

Deborah Jackson

121.2012 vacation hours @ \$50.49 per hour	\$6,119.76
Total:	\$6,119.76

In accordance with the July 2008 Policy, I am requesting you verify the availability of the funds from the Retirement Stabilization Fund, prepare the Council Order, and continue the process in order that my staff can input the information in MUNIS and issue payments to this former employee upon Council approval.

Thank you for your cooperation, and if you should have any questions, please do not hesitate to contact me.

CITY OF SALEM
APPROVAL-SICK DAYS/VACATION BUY-BACK

From: Department Assessor's Date 4/20/21

Authorized Signature: [Signature]
Department Head/City or Business Manager/School

NAME: Deborah Jackson

CALCULATION

VACATION HOURS # 121.2012 @ \$ 50.49 = \$ 6,119.76

SICK HOURS # _____ @ \$ _____ = \$ _____

PRO-RATED STIPENDS # _____ @ \$ _____ = \$ _____

OTHER # _____ @ \$ _____ = \$ _____

Total Amount Due: \$ 6,119.76

Please attach corresponding PAF or other backup to this sheet.

Reason: Retired - 4/14/2021

For Human Resources's Use Only:

- VACATION HOURS
- SICK HOURS
- PER ACCRUAL REPORT
- OTHER

Org and Object: 83113 - 5146

Recommendation:

Approved

[Signature]
H R Director/City or Superintendent/Schools



CITY OF SALEM

In City Council,

Ordered:

May 27, 2021

That the sum of Six Thousand Dollars (\$6,000.00) is hereby transferred and appropriated from the Receipts Reserved funds listed below to the Department of Public Services Burial Account (14112-5383) in accordance with the recommendation of Her Honor the Mayor.

From		To		Amount
2430-4800	R/Res Sale of Lots	14112-5383	DPS Burial	\$ 4,000.00
2431-4800	R/Res Sale of Vaults	14112-5383	DPS Burial	2,000.00
Total				\$ 6,000.00



CITY OF SALEM, MASSACHUSETTS

Kimberley Driscoll
Mayor

May 27, 2021

To the City Council
City Hall
Salem, Massachusetts

Ladies and Gentlemen of the Council:

Enclosed herewith is a request for an appropriation of Six Thousand Dollars (\$6,000.00) from the "Receipts Reserved" funds listed below to the Department of Public Services Burial Account (14112-5383).

FROM			TO	AMOUNT
2430-4800	R/Res Sale of Lots	14112-5383	DPS Burial	\$4,000.00
2431-4800	R/Res Sale of Vaults	14112-5383	DPS Burial	\$2,000.00
			Total:	<u>\$6,000.00</u>

This appropriation is necessary to allow for the burial services and operations for fourth quarter of FY 2021.

I recommend passage of the accompanying Order.

Very truly yours,

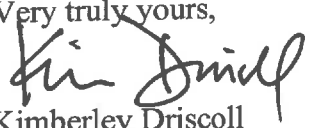
Kimberley Driscoll
Mayor



KIMBERLEY DRISCOLL
MAYOR

DAVID KNOWLTON P.E.
DIRECTOR OF PUBLIC SERVICES

CITY OF SALEM, MASSACHUSETTS

DEPARTMENT OF PUBLIC SERVICES
5 JEFFERSON AVENUE - FACILITY LOCATION
98 WASHINGTON STREET - MAILING ADDRESS
SALEM, MASSACHUSETTS 01970

TEL. (978) 744-3302
FAX (978) 744-6820
DKNOWLTON@SALEM.COM

May 5, 2021

The Honorable Mayor Kimberly Driscoll
City of Salem
93 Washington Street
Salem, Massachusetts 01970

Subject: Burial Service for Q4FY21

Dear Mayor Driscoll,

We respectfully request an appropriation of funds in the amount of Six Thousand, (\$6,000.00) from the following accounts:

2430-4800 Sale of Lots	\$4,000
2431-4800 Sale of Vaults	\$2,000

to be transferred into the Public Service Burial Services Line 14112-5383. This appropriation will allow for the burial services and operations for the fourth quarter of Fiscal Year 2021.

Respectfully yours,

David Knowlton
Director of Public Services

Cc: Frederique Phanor
Robert LeBlanc
File Copy

CITY OF SALEM - Finance Department

Free Cash, W & S R/E, R/Res & Budget Transfer Request Form

From: DPS Department [Signature] Department Head Authorizing Signature 5/5/21 Date

Budget or R/Res Transfers

To: 14112-5383 (Org/Object) Desc: Burial Services Budget Amt: 53,175.02 Balance: 2283.94

From: 2430-4600 Desc: Sale of Lots Budget Amt: 0 Balance: 8593

(*Note - Please include letter to Mayor for Transfers from different Personnel & Non-personnel lines)

Current Balance in Receipts Reserved Fund Above (if applicable) - \$ _____ Date: _____

Free Cash or Retained Earnings (W/S) (Org/Object) Desc: _____ Budget Amt: _____ Balance: _____

Please circle one

Amount Requested: \$ 4,000

Reason (Be Specific) Transfer of funds needed for burial services @ cemetery

For Finance Department and Mayor's Use Only:

Budget Transfer Mayor Approval City Council Approval
 Free Cash Appropriation - City Council Approval - Gen Fund \$ _____ Free Cash Balance
 R/E Appropriation - Water \$ _____ R/E Balance R/E Appropriation Sewer \$ _____ R/E Balance
 Receipts Reserve - City Council Approval \$ _____ R/Res Fund Balance
 Raise & Appropriate Other _____

Recommendation: Approved Denied _____ Finance Director

Completed: Date: _____ By: _____ CO # _____ JE#: _____ Transfer #: _____

CITY OF SALEM - Finance Department

Free Cash, W & S R/E, R/Res & Budget Transfer Request Form

From: DPS Department [Signature] Department Head Authorizing Signature 5/5/21 Date

Budget or R/Res Transfers To: 14112-5383 (Org/Object) Desc: Burial Services Budget Amt: 53,175.02 Balance: 2283.94

From: 2431-4800 (Org/Object) Desc: Sale of vaults Budget Amt: 0 Balance: 4,876.39

(*Note - Please include letter to Mayor for Transfers from different Personnel & Non-personnel lines)

Current Balance in Receipts Reserved Fund Above (if applicable) - \$ _____ Date: _____

Free Cash or Retained Earnings (W/S) To: _____ (Org/Object) Desc: _____ Budget Amt: _____ Balance: _____

Please circle one

Amount Requested: \$ 2,000

Reason (Be Specific) Transfer of funds needed for burial services @ cemetery

For Finance Department and Mayor's Use Only:

Budget Transfer Mayor Approval City Council Approval
 Free Cash Appropriation - City Council Approval - Gen Fund \$ _____ Free Cash Balance
 R/E Appropriation - Water \$ _____ R/E Balance R/E Appropriation Sewer \$ _____ R/E Balance
 Receipts Reserve - City Council Approval \$ _____ R/Res Fund Balance
 Raise & Appropriate Other _____

Recommendation: Approved Denied _____ Finance Director

Completed: Date: _____ By: _____ CO # _____ JE#: _____ Transfer #: _____



CITY OF SALEM

In City Council,

Ordered:

May 27, 2021

Per MGL Chapter 44 Section 64 which allows for a municipality to pay for prior fiscal year invoices using current fiscal year appropriations by two-thirds vote of the City Council we request the sum of Two thousand, four hundred eighty-two dollars and Ninety-Six Cents (\$2,482.96) of outstanding Fiscal Year 2020 invoices is hereby allowed to be paid from the Fiscal Year 2021 Building Department budget as listed below in accordance with the recommendation of Her Honor the Mayor.

Department	Payee	Amount
Public Properties/Building		\$ 2,482.96
Total		\$ 2,482.96



CITY OF SALEM, MASSACHUSETTS

Kimberley Driscoll
Mayor

Office of the Mayor

May 27, 2021

Honorable Salem City Council
Salem City Hall
Salem, MA 01970

Ladies and Gentlemen of the Council:

Enclosed please find an Order to authorize the payment of two FY2020 invoices that were received after the end of the fiscal year.

Pursuant to MGL Chapter 44, section 64, a two-thirds vote of the City Council is required to authorize the payment of previous fiscal year invoices using current fiscal year appropriations. The two invoices total \$2,482.96 and are for the cost of postage for mailings from the Collector's Office. I recommend adoption of the enclosed Order and invite you to contact Finance Director Anna Freedman should you have any questions concerning it.

Sincerely,

Kimberley Driscoll
Mayor
City of Salem



CITY OF SALEM, MASSACHUSETTS

BUILDING DEPARTMENT
98 WASHINGTON STREET, 2ND FLOOR
TEL: 978-745-9595

KIMBERLEY DRISCOLL
MAYOR

THOMAS ST. PIERRE
DIRECTOR OF PUBLIC PROPERTIES/BUILDING COMMISSIONER

To: Dominick Pangallo, Chief Administrative Aide to the Mayor
From: Thomas St. Pierre, Director of Public Properties/Building Commissioner
Date: May 3, 2021
Re: Request to Pay Invoices

COO

This memo has been prepared to request payment of two (2) invoices for the FY 2020 payment in lieu of postage for Collectors Office by services provided by Kelly & Ryan Associates, Inc. These bills are past due since they were not received by June 30, 2020, which led to them not being paid in FY 2020.

We are requesting The City Council approval to pay \$2,482.96 to Kelly & Ryan Associates, Inc. (Vendor #8315).

The bills:	Inv. Date	Inv. #	Description	Inv. Amount/ Balance Due
	04/28/2020	20-3507	Postage for Collectors Voucher #753693	\$ 701.37
	06/04/2020	20-4408	Postage for Collectors Voucher #753699	<u>\$1,781.59</u>
TOTAL DUE:				\$2,482.96

If you have any questions, or require additional information, please call me at 978-619-5640. The Inspectional Services Department is available to meet with the City Council to discuss this request.

Thank you.

cc: Laurie Giardella, Finance Director



CITY OF SALEM

In City Council, May 27, 2021

ORDERED: That the Salem City council vote, pursuant to the provisions of MGL Chapter 44, Section 53E ½ to authorize the establishment of the revolving funds for fiscal year 2022 has herein described. Expenditures from said funds shall not exceed the amount of funds received in the respective accounts or as authorized as stated, shall come from any funds received by respective boards for performing services, shall be used solely for the purpose of implementing the programs delineated and shall be approved by a majority vote of any respective boards in accordance with Her Honor the Mayor.

Dept.	Fund Name	Fund #	Programs & Purposes	Type of Receipts Credited	Authorization for Spending	FY 2022 Budget Request Maximum Annual Expenditures
COA	COA Programs	2374	To defray program costs including instructors, presenters, entertainment, decorations, food, etc.	Revenues and fees charged for programs	COA Director and Mayor	40,000.00
Electrical	Telecom	2376	To fund public information technology, telecommunication and electrical initiatives and projects	Application fees and rental revenue from telecommunications attachments pursuant to sections 12-125 and 12-170 of the City Ordinances	City Electrician and Mayor	50,000.00
Fire	R/A Local Emergency Planning Comm	2433	Training and special equipment needed to respond to hazardous materials incidents per CH 21E	Fees charged to persons spilling or releasing hazardous materials	Fire Chief and Mayor	40,000.00
Harbormaster	R/A WI STORAGE	2368	To Fund Capital items for Harbormaster, maintenance costs of equipment and maritime access projects.	Fees charged for Boat and Float Storage at Winter Island and Kernwood Marina	Harbormaster and Mayor	50,000.00
Health Dept	Health Clinics	2364	To support vaccination program and other Health Promotion activities of the Health Department	Reimbursements from vaccination programs	Health Agent and Mayor	20,000.00
Mayor	Special Events	2361	To cover expenses for Fireworks, bands, portable potties and other unanticipated expenditures	Revenue from RFP's for services from vendors, and from misc sponsorships.	Mayor	125,000.00

Dept.	Fund Name	Fund #	Programs & Purposes	Type of Receipts Credited	Authorization for Spending	FY 2022 Budget Request Maximum Annual Expenditures
Recreation	Winter Island Store	2362	To increase and replenish store inventory as needed and to enhance and maintain Winter Island Store & Facilities.	Revenue from sale of inventory/services at Winter Island.	Recreation Director and Mayor	40,000.00
Recreation	Proctor's Ledge	2384	For Maintenance of Proctor's Ledge site	Revenue of 25 cents from the sale of each ticket at the Witch House.	Recreation Director and Mayor	12,000.00
Recreation	Road Race Fees	2385	For Park Maintenance	Field rental fees and five percent of race and event registration fees.	Recreation Director and Mayor	6,000.00
Recreation	Dog Park	2435	Renovations and Maintenance of Dog Park at Leslie's Retreat Park.	Fee charged for pass to use dog park (pooch pass). \$25. annually for pass.	Recreation Director and Mayor	5,000.00
Recreation	Park & Rec Public Access	2452	To be used for the operation and maintenance of Winter Island and McCabe Marina	Parking and launch fees charged at McCabe Marina & Winter Island	Recreation Director and Mayor	50,000.00
Recreation	Salem Willows Meters	2459	Renovations and Maintenance of Willows Park.	Money generated from Willows Meters	Recreation Director and Mayor	30,000.00
Recreation	Witch House	2499	To support Salem Award committee and the Salem Witch Trial Memorial	25 cent surcharge to tickets beginning in May 2009	Recreation Director and Mayor	10,000.00
Planning & Community Development	Old Town Hall	2373	Maintenance costs of old town hall	Rental revenue of old town hall	Director of Planning and Mayor	50,000.00
Planning & Community Development	Derby Square/Artists' Row	2375	Improvements for Derby Square and Artists' Row including outdoor furniture, signage, lighting, public art, marketing and stipends for performers	Vendor fees from Derby Square Flea/Salvage Art Market, Rent and Vendor Fees at Artists Row	Director of Planning and Mayor	50,000.00
Planning & Community Development	Utility Energy Credit Fund	2377	To be used for City projects or programs that reduce utility costs, use, and/or emissions. This may include personnel costs associated with participation in the programs that generate the credits.	Credits or payments received for City projects or programs that specifically result in reduction in utility costs, use, or emissions.	Director of Planning and Mayor	250,000.00
Planning & Community Development	Bike Sharing	2383	To receive and expend revenue from bike share program for system operation and promotion	Revenue from rentals and annual memberships	Director of Planning and Mayor	50,000.00

Dept.	Fund Name	Fund #	Programs & Purposes	Type of Receipts Credited	Authorization for Spending	FY 2022 Budget Request Maximum Annual Expenditures
Planning & Community Development	Salem Ferry/Salem Wharf Operational	2453	Fund operational costs of the Salem Ferry and operating, maintenance, capital repairs, security, utilities related to Salem Wharf	Fees received during the season for leasing of the Salem Wharf, MBTA Salem Passes, and fuel reimbursements	Director of Planning and Mayor	500,000.00
Insp Services	Abandoned Prop Maint	2371	To maintain abandoned and foreclosing residential and commercial properties	Registration fees (\$300.00) for vacant and/or foreclosing residential properties.	Inspectional Services Director and Mayor	85,000.00
Public Services	Tree Replacement	New 2330	To replace trees removed during construction as directed by the Tree Warden or Planning Board	Revenue from contributions per the Tree Ordinance or Planning Board decision	Director of Public Services And Mayor	30,000.00
Engineering	Traffic Island	2439	Projects related to City beautification events including Traffic Island, Beautification, and special events	Primarily from: Traffic Island Sponsorships, Special Events Revenues, Event and Beautification effort sponsors	City Engineer and Mayor	20,000.00
School-SBO	Building Rental	2601	Building Rental	Payments for rental of building by outside groups	School Committee and Mayor	225,000.00
School-SPED	Early Childhood	2608	Pre-School Tuition	Tuition payments for students attending the pre-school program at the Early Childhood Center	School Committee and Mayor	100,000.00
School-Trans	School Busing	2614	School Bus pass	Purchases of school bus passes	School Committee and Mayor	160,000.00
School-HS	Night/Summer School	2620	Night School Tuition	Tuition payments for students attending the night school program	School Committee and Mayor	50,000.00
School-SPED	Special Education Tuition	2627	Special Education Tuition	Tuition Payments for students from other districts attending Special Education programs in Salem	School Committee and Mayor	300,000.00
School-Auto	SHS Automotive	2645	To pay for parts and materials for automotive repairs to vehicles brought in to the HS Automotive Vocational School by Citizens	Fees charged for parts and materials for automotive repairs to vehicles brought in by citizens	School Committee and Mayor	50,000.00
					Totals	2,398,000.00



CITY OF SALEM, MASSACHUSETTS

Kimberley Driscoll
Mayor

Office of the Mayor

May 27, 2021

Salem City Council
City Hall
93 Washington Street
Salem, MA 01970

Ladies and Gentlemen of the City Council:

Enclosed please find supporting Orders and Ordinances necessary for the adoption of the FY2022 City budget. These items include:

1. Council Order authorizing the revolving funds.
2. Council Order appropriating from short-term capital.
3. Bond Order for general fund capital.
4. Bond Order for water and sewer capital.
5. Ordinance for water rate.
6. Ordinance for sewer rate.

I recommend adoption of the enclosed Orders and Ordinances as part of the FY2022 budget process and welcome any questions you may have regarding them during our regular budget hearings.

Sincerely,

Kimberley Driscoll
Mayor
City of Salem



City of Salem, Massachusetts

Finance Department
93 Washington Street
Salem, MA 01970
www.salem.com

Kimberley L. Driscoll, Mayor

Anna Freedman, Finance Director

May 27, 2021

The Honorable Kimberley L. Driscoll
Mayor of Salem
93 Washington Street
Salem, Massachusetts 01970

RE: Revolving Funds

Dear Mayor Driscoll:

Massachusetts General Law Chapter 44 Section 53E ½ allows for a city the annually authorized the use of revolving funds by departments which shall be accounted for separately from all other monies in the city. The revenues collected for each program are credited to individual accounts and the expenditures made from these funds can be made without further appropriation in connection with the program that each revolving fund supports.

The City Council shall vote each year prior to the respective fiscal year for the authorization of such account. Attached is a summary of the revolving funds of the City that lists the department, fund name, fund account number, program and purpose, type of receipt credited, and the maximum dollar spending allowance from each revolving fund.

This annual process is part of the budget process, and, as such, I recommend that we authorize all accounts as listed on the attached council order.

Respectfully yours,

A handwritten signature in black ink, appearing to read "Anna Freedman".

Anna Freedman
Finance Director

CITY OF SALEM

In the year Two Thousand and Twenty-One

An Ordinance to amend an Ordinance relative to Rates for Use of Water

Be it ordained by the City Council of the City of Salem, as follows:

Chapter 46, Section 66 is hereby amended by deleting subparagraph (b) in its entirety and replacing it with the following:

“(b) The rate for all water furnished by meter measurements effective July 1, 2021 shall be as follows:

- (1) Residential, per 100 cubic feet \$3.64
- (2) Nonresidential, per 100 cubic feet \$4.92

Section 2. Chapter 46, Section 66 is hereby further amended by deleting subparagraph (e) in its entirety and replacing it with the following:

“(e) The minimum rate for residential metered water for each quarter shall be \$36.40 per 1000 cubic feet effective July 1, 2021.

The use of all water and sewer funds and SESD funds shall be excluded from all private development projects.”

Section 3. This Ordinance shall take effect as provided by City Charter.



CITY OF SALEM, MASSACHUSETTS

Kimberley Driscoll
Mayor

Office of the Mayor

May 27, 2021

Salem City Council
City Hall
93 Washington Street
Salem, MA 01970

Ladies and Gentlemen of the City Council:

Enclosed please find supporting Orders and Ordinances necessary for the adoption of the FY2022 City budget. These items include:

1. Council Order authorizing the revolving funds.
2. Council Order appropriating from short-term capital.
3. Bond Order for general fund capital.
4. Bond Order for water and sewer capital.
5. Ordinance for water rate.
6. Ordinance for sewer rate.

I recommend adoption of the enclosed Orders and Ordinances as part of the FY2022 budget process and welcome any questions you may have regarding them during our regular budget hearings.

Sincerely,

Kimberley Driscoll
Mayor
City of Salem

CITY OF SALEM

In the year Two Thousand and Twenty-One

An Ordinance to amend an Ordinance relative to Sewer User Charges

Be it ordained by the City Council of the City of Salem, as follows:

Chapter 46, Section 230 is hereby amended by deleting subsection (c) in its entirety and replacing it with the following:

“(c) The rates for sewer use charges effective July 1, 2019 shall be as follows:

Residential, per 100 cubic feet...	\$ 7.41
Nonresidential, per 100 cubic feet up to 25,000 cubic feet per month	\$11.22
Nonresidential, per 100 cubic feet for 25,000 cubic feet and greater per month	\$14.37

The use of all water and sewer funds and SESD funds shall be excluded from all private development projects.”

Section II. This Ordinance shall take effect as provided by City Charter.



CITY OF SALEM, MASSACHUSETTS

Kimberley Driscoll
Mayor

Office of the Mayor

May 27, 2021

Salem City Council
City Hall
93 Washington Street
Salem, MA 01970

Ladies and Gentlemen of the City Council:

Enclosed please find supporting Orders and Ordinances necessary for the adoption of the FY2022 City budget. These items include:

1. Council Order authorizing the revolving funds.
2. Council Order appropriating from short-term capital.
3. Bond Order for general fund capital.
4. Bond Order for water and sewer capital.
5. Ordinance for water rate.
6. Ordinance for sewer rate.

I recommend adoption of the enclosed Orders and Ordinances as part of the FY2022 budget process and welcome any questions you may have regarding them during our regular budget hearings.

Sincerely,

Kimberley Driscoll
Mayor
City of Salem

Resolution
Recognizing the Service of Salem Police Department Canines
“Turbo” and “Axel”

WHEREAS: The Salem Police Canine (K9) Unit was formed in 2012 as a result of fundraising efforts by the Salem community, including the Mack Park Neighborhood Association, the Salem Lions Club, the Salem Moose Family Center and in partnership with the Massachusetts Vest-A-Dog organization; and

WHEREAS: The Salem community has remained steadfast in its support – through fundraising, engagement, and encouragement – of the K9 program since its inception; and

WHEREAS: On May 27, 2021 we recognize the service of recently retired Salem Police Department K9’s “Turbo” and “Axel”; and

WHEREAS: Both K9 Turbo and K9 Axel joined the ranks of the Salem Police Department in 2012 as founding members of the K9 Unit and served honorably and faithfully until their respective retirements on 26 August 2020 and 26 January 2021; and

WHEREAS: The Mayor and City Council recognize that both Turbo and Axel have provided the residents of Salem invaluable service by assisting officers in the apprehension of suspects, the discovery of evidence, assisting in locating missing persons, and being outstanding police ambassadors to the community.

NOW THEREFORE BE IT RESOLVED: That the Mayor of the City of Salem and the Salem City Council, on behalf of the residents of Salem, express our appreciation to K9 Turbo and K9 Axel for their combined seventeen years of loyal and faithful service to our community.

AND BE IT FURTHER RESOLVED: That this Resolution be made a matter of record of these proceedings, and that a copy of this Resolution and a copy of the City Seal, be presented to the Salem Police Department for display at the police station as a lasting tribute to the service of these fine animals.



CITY OF SALEM, MASSACHUSETTS

Kimberley Driscoll
Mayor

Office of the Mayor

May 27, 2021

Honorable Salem City Council
Salem City Hall
Salem, MA 01970

Ladies and Gentlemen of the Council:

Enclosed please find a resolution commending police K9s Turbo and Axel, both of whom retired in this past year after nearly a decade's worth of service to our community. This resolution is submitted in partnership with the Salem Police Department.

I recommend adoption of the enclosed resolution and hope you will join me thanking their handling officers and the many organizations and individuals whose support has made our K9 program possible. Please also join me in thanking Turbo and Axel for their service and in wishing both of these good boys the very best in their well-earned retirement.

Sincerely,

Kimberley Driscoll
Mayor
City of Salem

CITY OF SALEM

In the year Two Thousand and Twenty One

An Ordinance to amend an Ordinance relative to Traffic Ch. 42, Sec. 50B,
“Handicapped Zones, Limited Time”

Be it ordained by the City Council of the City of Salem, as follows:

Section I. Amending Chapter 42, Section 50B – “Handicapped Zones, Limited Time” is hereby amended by repealing the following:

Repeal - Lathrop Street, in front of #18 Lathrop Street, beginning four (4) feet west of the driveway at 18 Lathrop Street, running west for twenty (20) feet.

Section II. This Ordinance shall take effect as provided by City Charter.



City of Salem, Massachusetts
Office of the City Council
City Hall



REQUEST FOR TRAFFIC ORDINANCE RECOMMENDATION

MEMO TO: Lt. David Tucker Police Traffic Division
FROM: Councillor Madore DATE: 5/25/2021

In accordance with the Council Rule 32A, I hereby request your recommendation for the following Traffic Ordinance:

NAME OF STREET Lathrop Street

TYPE OF STREET CHANGE Repeal - Handicapped Parking, Limited Time

DESCRIPTION OF AREA WHERE CHANGE IS REQUESTED In front of 18 Lathrop Street, the existing HP parking space is no longer used and should be removed.

COUNCILLOR'S COMMENTS/EXPLANATION The resident of 18 Lathrop Street who had originally requested the HP space has since moved. The space is no longer needed by any nearby residents, and the sign should be removed.

POLICE TRAFFIC DIVISION RECOMMENDATION

The Police Traffic Division hereby submits the following recommendation for the above request:

APPROVAL
 DENIAL
 TRIAL PERIOD

CHAPTER: 42 SECTION: 50B TITLE: Handicapped Zones, Limited Time

DESCRIPTION: Repeal - Lathrop Street, in front of #18 Lathrop Street, beginning four (4) feet west of the driveway at 18 Lathrop Street, running west for twenty (20) feet.

COMMENTS (IF ANY): _____

Lt. David Tucker
POLICE TRAFFIC DIVISION

RETURN THIS FORM TO THE CITY CLERK'S OFFICE

City of Salem Clerk's Office, 93 Washington St. Salem Massachusetts 01970

(978) 745-9595 ext 41202 www.salem.com

CITY OF SALEM

In the year Two Thousand and Twenty One

An Ordinance to amend an Ordinance relative to Traffic Ch. 42, Sec. 50B,
"Handicapped Zones, Limited Time"

Be it ordained by the City Council of the City of Salem, as follows:

Section I. Amending Chapter 42, Section 50B – "Handicapped Zones, Limited Time" is hereby amended by repealing the following:

Repeal – Emerton Street, easterly side along #2 Emerton Street for a distance of twenty (20) feet.

Section II. This Ordinance shall take effect as provided by City Charter.



City of Salem, Massachusetts
Office of the City Council
City Hall



REQUEST FOR TRAFFIC ORDINANCE RECOMMENDATION

MEMO TO: Lt. David Tucker Police Traffic Division
FROM: Councillor Madore DATE: 5/25/2021

In accordance with the Council Rule 32A, I hereby request your recommendation for the following Traffic Ordinance:

NAME OF STREET Emerton Street

TYPE OF STREET CHANGE Repeal - Handicapped Parking, Limited Time

DESCRIPTION OF AREA WHERE CHANGE IS REQUESTED In front of 2 Emerton Street, the existing HP parking space is no longer used and should be removed.

COUNCILLOR'S COMMENTS/EXPLANATION The resident of 1 Emerton Street, who had originally requested the HP space which was installed at 2 Emerton Street, has since moved. The space is no longer needed by any nearby residents, and the sign should be removed.

POLICE TRAFFIC DIVISION RECOMMENDATION

The Police Traffic Division hereby submits the following recommendation for the above request:

APPROVAL

DENIAL

TRIAL PERIOD

CHAPTER: 42 SECTION: 50B TITLE: Handicapped Zones, Limited Time

DESCRIPTION: Repeal - Emerton Street, easterly side along #2 Emerton Street for a distance of twenty (20) feet.

COMMENTS (IF ANY):

POLICE TRAFFIC DIVISION

RETURN THIS FORM TO THE CITY CLERK'S OFFICE

City of Salem Clerk's Office, 93 Washington St, Salem Massachusetts 01970

(978) 745-9595 ext 41202 www.salem.com

CITY OF SALEM

In the year two thousand and Twenty-One

An Ordinance to amend an Ordinance relative Zoning

Be it Ordained by the City Council of the City of Salem, as follows:

Section 1. Chapter 8.6 – Waterfront Industrial Overlay District (WIOD) of the City of Salem Zoning Ordinance is hereby amended by adding a new table entry to 8.6.3 – Permitted Uses with the following:

PRINCIPAL USES	WIOD
C. HOUSING USES	
Planned Unit Development.....	N

Section 2. This Ordinance shall take effect as provided by City Charter.



David R. Flewelling
Specialist 2 Construction
Comcast Cable Communications
9 Forbes Road, Suite 9B
Woburn, MA 01801
Cell - 617-279-7864
dave_flewelling@comcast.com

May 25, 2021

Ms. Maureen Fisher
Salem Assistant City Clerk
City Hall
93 Washington Street
Salem, MA 01970

RE: 260-262 Essex Street Salem
Grant of Location-Petition

Dear Ms. Fisher:

Enclosed please find materials supporting Comcast request for a grant of location from the Salem City Council. The work associated with the attached petition is for the purpose of installing a new conduit from the existing Comcast Manhole to a new vault located in the sidewalk located at 260-262 Essex Street. For a more detailed description of the work please refer to the attached construction plans.

I look forward to the opportunity to address this matter in further detail at the next Salem City Council Meeting. Should you have any questions or concerns, please feel free to contact me at (617) 279-7864.

Sincerely,

A handwritten signature in black ink that reads "David R. Flewelling".

David R. Flewelling
Comcast
Specialist 2, Construction

Enclosure (3)

PETITION OF COMCAST FOR LOCACTION FOR CONDUITS, MANHOLES AND
POLES

To the City Council for the City of Salem, Massachusetts:

Respectfully represents Comcast Cable Communications Management LLC., a company incorporated for the distribution of broadband services, that it desires to construct a line for such broadband under the public way or ways hereinafter specified.

Essex Street: Starting at the existing Comcast Manhole excavating to place (1) 4" PVC conduit 31'+/_ to a proposed 24" X 36" vault located in sidewalk of 260-262 Essex Street.

Wherefore, your petition prays that, after due notice and hearing as provided by law, the City Council may by Order grant your petitioner permission to construct, and a location for, such a line of conduits, manholes and poles with the necessary wires and cables therein, said conduits manholes and poles to be located, substantially as shown on the plan made by Dewsnap Engineering dated May24,2021 and filed here with, under the following public way or ways of said City of Salem.

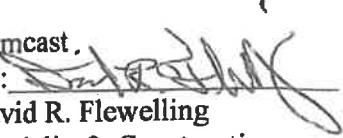
Comcast.
By: 
David R. Flewelling
Specialist 2, Construction

Dated this May 25,2021

City of Salem, Massachusetts

Received and filed _____, 2021.

GENERAL LEGEND

- SMH SEWER MANHOLE
- WG WATER GATE
- DMH DRAIN MANHOLE
- GG GAS GATE
- EMH ELECTRIC MANHOLE
- CMH COMCAST MANHOLE
- VCC VERT. GRANITE CURB
- PM PARKING METER
- SP SIGN POST
- ADA HANDICAP
- C COMCAST UNDERGROUND CONDUIT
- D DRAIN LINE
- G GAS LINE
- W WATER LINE
- S SEWER LINE
- E UNDERGROUND ELECTRIC LINE
- T UNDERGROUND TELEPHONE
- PROPOSED COMCAST UNDERGROUND CONDUIT(S)

PROPOSED COMCAST VAULT (2'X3') PLACED OVER EXISTING COMCAST CONDUIT. SIDEWALK PANEL TO BE REPLACED PER CITY OF SALEM ENGINEERING & DPW STANDARDS

R & C REALTY TRUST
256 ESSEX STREET
PARCEL ID: 35-0012-0
EXISTING BUILDING

PROPOSED COMCAST 1-4" PVC, SCH. 40 UNDERGROUND CONDUIT. LENGTH = 31'-0" (EXIST. COMCAST MANHOLE TO PROP. COMCAST VAULT)

AFTER THE INSTALLATION OF THE 2'X3' VAULT IN THE CONCRETE SIDEWALK, THE CONCRETE PANEL SHALL BE REPLACED PER CITY OF SALEM ENGINEERING AND DPW STANDARDS.

"CONDO UNITS"
280-282 ESSEX STREET
PARCEL ID: 26-0646-801,802 & 803
EXISTING BUILDING

EXISTING BUILDING
N/F
5-BNK SALEM, LLC
259 ESSEX STREET
PARCEL ID: 35-0009-0

EXISTING BUILDING
N/F
DEILIS PROPERTIES
265 ESSEX STREET
PARCEL ID: 26-0445-0

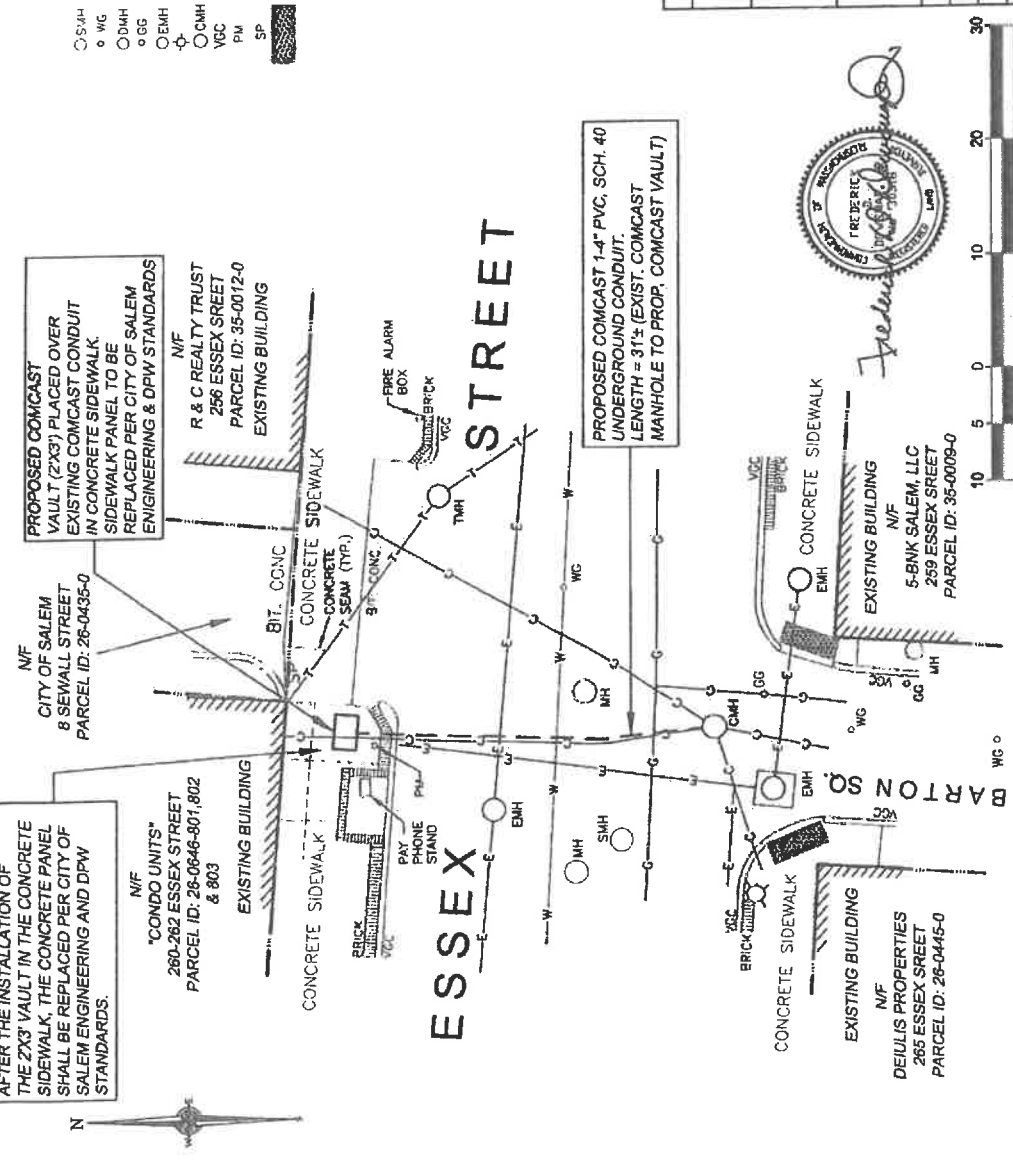

THIS PLAN IS DRAWN ON 11" X 17" PAPER

WARD 2, PRECINCT 2	
PROPOSED COMCAST UNDERGROUND	
ESSEX COUNTY	
PLAN OF LAND	
IN SALEM, MA	
Prepared for:	COMCAST 9 FORBES ROAD, SUITE 9B WOBURN, MA 01897
Date:	MAY 24, 2021
Checked By:	F.D.D. & P.A.D.
Drawn By:	P.A.D.
Field By:	P.A.D. & A.C.D.
Scale:	1" = 10'
PROJECT LOCATION:	264 ESSEX STREET
Prepared by:	DEWSNAP ENGINEERING ASSOC. LLP 178 Lincoln Avenue - Salem, MA 01968 Tel: (781) 283-0595
Sheet No.	1 of 3



DETAIL NOTE:

- The details depicted are for general reference only. The final product used shall be the responsibility of the general contractor and shall be of equal or greater material than that depicted and shall conform to the Engineering/DPW Standards for the state, city/town where the project is located.

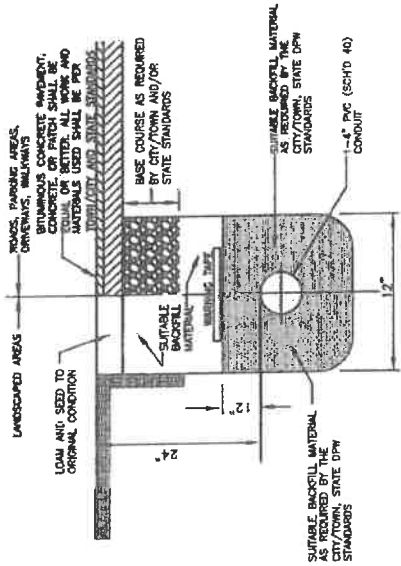

GENERAL CATV TRENCH DETAIL
FOR 4" PVC, SCH. 40 CONDUIT
NOT TO SCALE

NOTES:

- These plans were prepared from record plan data on file at the City of Salem, Registry of Deeds and various utility companies.
- The locations of underground utilities shown are based on above ground structures and record drawings, if any, provided to the Surveyor. The Locations of underground utilities/structures may vary from location hereon and are not warranted to be accurate and/or correct. Additional buried utilities/structures may be encountered. No excavations were performed during the progress of this survey to locate buried utilities/structures.
- Prior to any construction the Contractor shall notify DIG-SAFE at least 72 hours in advance at 811 (National Call Number) for verification of utilities and for field locations.
- It is the responsibility of the Utility Contractor installing the Comcast underground conduit to notify those utility companies not associated with the DIG-SAFE system to verify the locations of their respective utilities. Also, the installing contractor shall be responsible for repairing or replacing any traffic signal loops damaged during the installation of the new Comcast underground conduit.
- All work to be performed is the installation of a Comcast underground conduit and 2"x3" vault.
- All work shall conform to the approving authorities Engineering and DPW Standards.
- Prior to the start of any construction, the Utility Contractor shall confirm the number of conduits and the size of the conduit(s) for this project with the Comcast project Coordinator.
- Upon completion of the trench work for the day, the contractor shall backfill, compact and pave the trench and the work area shall be broom swept clean. In grassed areas the trench shall be loamed and seeded and hay mulch spread to keep the area stabilized until the grass has taken hold.
- Street/Property lines are not the result of a boundary survey and are considered to be approximate.

CONSTRUCTION NOTES:

- Following the Dig-Safe "mark out" and field verification of the existing underground utilities, the Proposed 4" PVC, Sch. 40 Comcast Conduit and Proposed 3'X3' manhole shall be adjusted in the field by the utility contractor to avoid being located over any existing utilities.

"NOTES & DETAILS"

PROPOSED COMCAST UNDERGROUND

ESSEX COUNTY

PLAN OF LAND

IN

SALEM, MA

Prepared for:	COMCAST 9 FORBES ROAD, SUITE 89 WOBURN, MA 01801	Scale:	As Shown
Date:	MAY 24, 2021	PROJECT LOCATION:	264 ESSEX STREET
Checked By:	F. D. & P.A.D.	WARD:	WARD 2, PRECINCT 2
Drawn By:	P.A.D.		
Field By:	P.A.D.		
		Sheet No. 2 of 3	



THIS PLAN IS DRAWN ON 11" X 17" PAPER

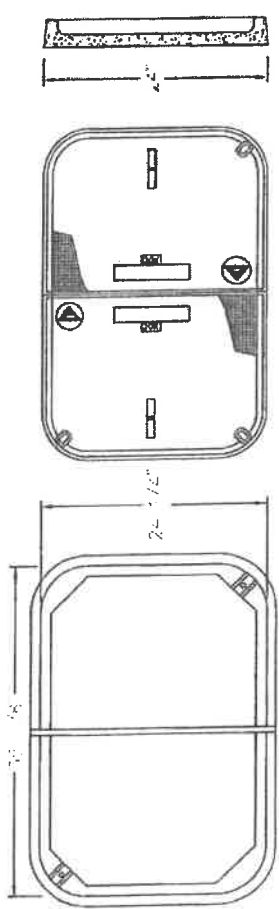
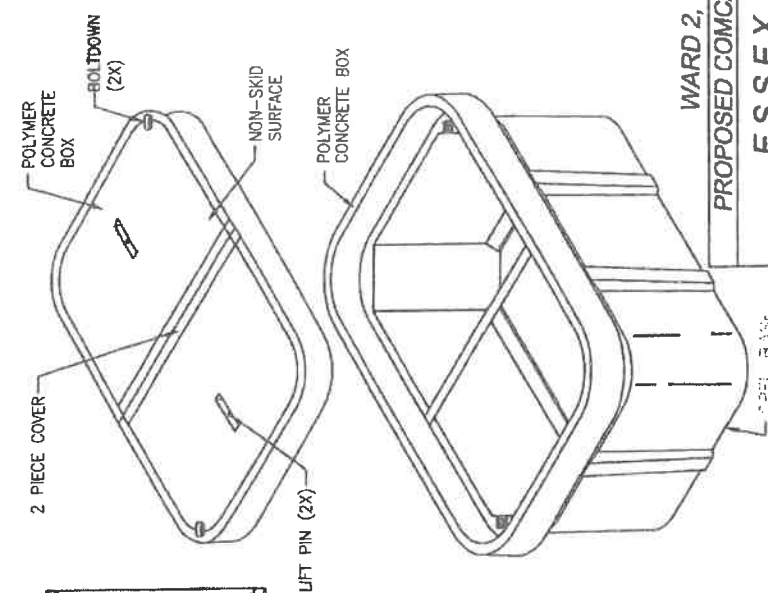

PLAN VIEW

2 PIECE POLYMER CONCRETE COVER

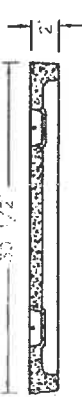

APPROX. WT. = 304 LBS.

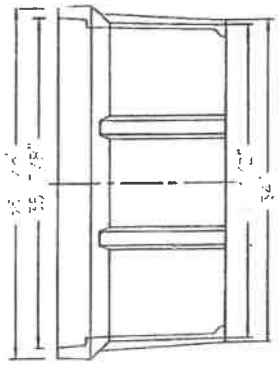

SIDE VIEW

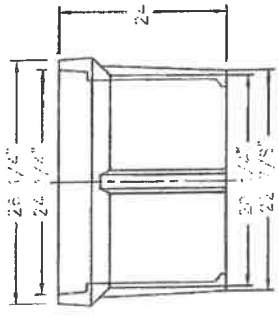

END VIEW

ARMORCAST 24" X 36" VAULT DETAIL
NOT TO SCALE



VAULT NOTES:
VAULTS SHALL BE AS MANUFACTURED BY ARMORCAST PRODUCTS COMPANY, CHASTWORTH, CA, 24" X 36" X 24" DEEP, TIER 22, 20K LOAD RATED, MODEL #A6001974HDAPCX24 WITH 2 PIECE COVERS.

THIS PLAN IS DRAWN ON 11" X 17" PAPER.

WARD 2, PRECINCT 2
PROPOSED COMCAST UNDERGROUND
ESSEX COUNTY
PLAN OF LAND
IN
SALEM, MA

Prepared for:	COMCAST 9 FORBES ROAD, SUITE 98 HUBBARD, MA 01801	Prepared BY:	DEWSNAP ENGINEERING ASSOC. LLP 172 Lincoln Avenue - Salem, MA 01966 Tel: (781) 235-6686
Date:	May 24, 2021	Scale:	As Shown
Checked By:	F.D.C. & P.A.D.	PROJECT LOCATION:	
Drawn By:	W.A.J.	264 ESSEX STREET SALEM, MA	
Field By:	N/A	Sheet No. 3 of 3	



David R. Flewelling
Specialist 2 Construction
Comcast Cable Communications
9 Forbes Road, Suite 9B
Woburn, MA 01801
Cell – 617-279-7864
dave_flewelling@comcast.com

May 25, 2021

Ms. Maureen Fisher
Salem Assistant City Clerk
City Hall
93 Washington Street
Salem, MA 01970

RE: 94 Washington Street Salem
Grant of Location-Petition

Dear Ms. Fisher:

Enclosed please find materials supporting Comcast request for a grant of location from the Salem City Council. The work associated with the attached petition is for the purpose of installing a new a new vault and conduit in the sidewalk located at 94 Washington Street. For a more detailed description of the work please refer to the attached construction plans.

I look forward to the opportunity to address this matter in further detail at the next Salem City Council Meeting. Should you have any questions or concerns, please feel free to contact me at (617) 279-7864.

Sincerely,

A handwritten signature in black ink, appearing to read "David R. Flewelling", is written over the typed name.

David R. Flewelling
Comcast
Specialist 2, Construction

Enclosure (3)



WASHINGTON STREET

WASHINGTON STREET

PROPOSED COMCAST 1-4" PVC, SCH. 40 UNDERGROUND CONDUIT. LENGTH = 16'; (EXISTING COMCAST MANHOLE TO PROPOSED COMCAST VAULT)

LP #6238
CONCRETE SIDEWALK

PROPOSED COMCAST VAULT (2'X3') IN CONCRETE SIDEWALK. SIDEWALK PANEL TO BE REPLACED PER CITY OF SALEM ENGINEERING & DPW STANDARDS

AFTER THE INSTALLATION OF THE 2'X3' VAULT IN THE CONCRETE SIDEWALK, THE CONCRETE PANEL SHALL BE REPLACED PER CITY OF SALEM ENGINEERING AND DPW STANDARDS.

LINE 2850 WASHINGTON, LLC
C/O GEORGE VERMET
30 WASHINGTON ST.
PARCEL ID: 35-016-0

APPROXIMATE LOCATION OF MASS DPW EASEMENT (PLAK#87, PLAK#1 - ESRD#) (PLAK#8 OF 1975 - ESRD#)

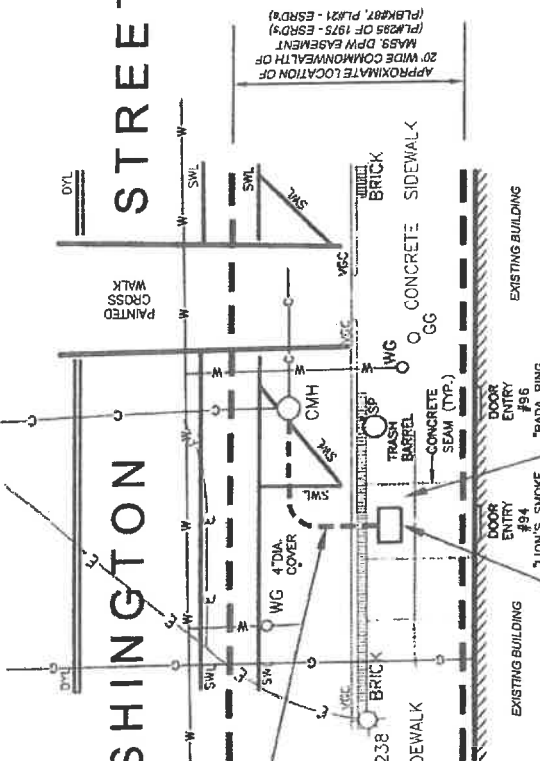

GENERAL LEGEND

- C --- COMCAST UNDERGROUND CONDUIT
- D --- DRAIN LINE
- G --- GAS LINE
- W --- WATER LINE
- S --- SEWER LINE
- E --- UNDERGROUND ELECTRIC LINE
- T --- UNDERGROUND TELEPHONE
- PROPOSED COMCAST UNDERGROUND CONDUIT(S)
- DOUBLE YELLOW LINE

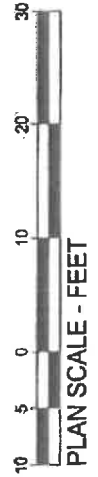

THIS PLAN IS DRAWN ON 11" X 17" PAPER

WARD 2, PRECINCT 2
PROPOSED COMCAST UNDERGROUND
ESSEX COUNTY
PLAN OF LAND
IN
SALEM, MA

Prepared for:	COMCAST 9 FORBES ROAD, SUITE 89 WOBURN, MA 01887	Prepared BY:	DEWSNAP ENGINEERING ASSOC. LLP 178 Lincoln Avenue - Salem, MA 01968 Tel: (781) 233-0585
Date:	MAY 24, 2021	Scale:	1" = 10'
Checked By:	F.D.D. & P.A.D.	PROJECT LOCATION:	94 WASHINGTON STREET
Drawn By:	P.A.D.		
Field By:	P.A.D. & A.C.D.		
	Sheet No. 1 of 3		

DETAIL NOTE:

1. The details depicted are for general reference only. The final product used shall be the responsibility of the general contractor and shall be of equal or greater material than that depicted and shall conform to the Engineering/DPW Standards for the state, city/town where the project is located.

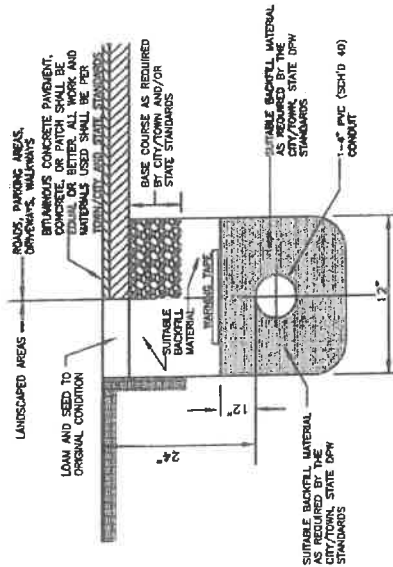

GENERAL CITY TRENCH DETAIL
FOR 4" PVC, SCH. 40 CONDUIT

NOT TO SCALE

NOTES:

1. These plans were prepared from record plan data on file at the City of Salem, Registry of Deeds and various utility companies.
2. The locations of underground utilities shown are based on above-ground structures and record drawings, if any, provided to the Surveyor. The Locations of underground utilities/structures may vary from location hereon and are not warranted to be accurate and/or correct. Additional buried utilities/structures may be encountered. No excavations were performed during the progress of this survey to locate buried utilities/structures.
3. Prior to any construction the Contractor shall notify DIG-SAFE at least 72 hours in advance at 811 (National Call Number) for verification of utilities and for field locations.
4. It is the responsibility of the Utility Contractor installing the Comcast underground conduit to notify those utility companies not associated with the DIG-SAFE system to verify the locations of their respective utilities. Also, the installing contractor shall be responsible for repairing or replacing any traffic signal loops damaged during the installation of the new Comcast underground conduit.
5. All work to be performed is the installation of a Comcast underground conduit and 2x3 vault.
6. All work shall conform to the approving authorities Engineering and DPW Standards.
7. Prior to the start of any construction, the Utility Contractor shall confirm the number of conduits and the size of the conduit(s) for this project with the Comcast project Coordinator.
8. Upon completion of the trench work for the day, the contractor shall backfill, compact and pave the trench and the work area shall be broom swept clean. In grassed areas the trench shall be loamed and seeded and hay mulch spread to keep the area stabilized until the grass has taken hold.
9. Street/Property lines are not the result of a boundary survey and are considered to be approximate.

CONSTRUCTION NOTES:

1. Following the Dig-Safe "mark out" and field verification of the existing underground utilities, the Proposed 4" PVC, Sch. 40 Comcast Conduit and Proposed 3X3 manhole shall be adjusted in the field by the utility contractor to avoid being located over any existing utilities.

"NOTES & DETAILS"
PROPOSED COMCAST UNDERGROUND
ESSEX COUNTY
PLAN OF LAND
IN
SALEM, MA



Prepared for:	COMCAST 8 FORBES ROAD, SUITE 88 WOBURN, MA 01801	Prepared By:	DEWSNAP ENGINEERING ASSOC. LLP 178 Lincoln Avenue - Saugus, MA 01906 Tel: (978) 233-0885
Date:	MAY 24, 2021	Scale:	As Shown
Checked By:	F.D.D. & P.A.D.	PROJECT LOCATION:	94 WASHINGTON STREET WARD 2, PRECINCT 2
Drawn By:	P.A.D.		
Field By:	P.A.D.		
Sheet No. 2 of 3			

THIS PLAN IS DRAWN ON 11" X 17" PAPER

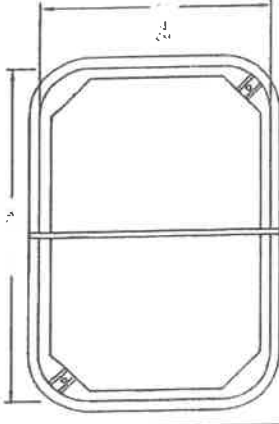

PLAN VIEW

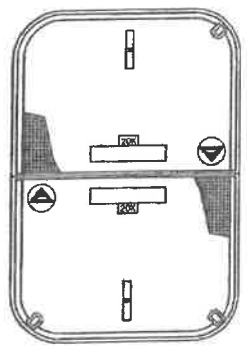

2 PIECE POLYMER CONCRETE COVER

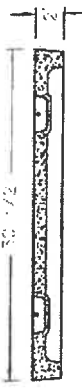

APPROX. WT. = 304 LBS.

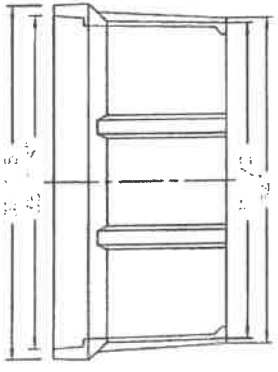

SIDE VIEW

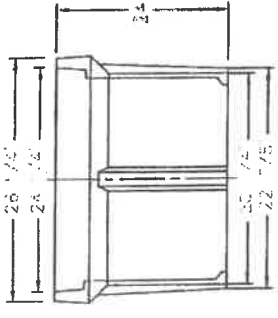

END VIEW

ARMORCAST 24" X 36" VAULT DETAIL
NOT TO SCALE

VAULT NOTES:
VAULTS SHALL BE AS MANUFACTURED BY ARMORCAST PRODUCTS COMPANY, CHASTWORTH, CA, 24" X 36" X 24" DEEP, TIER 22, 20K LOAD RATED, MODEL #A6001974HDAPCX24 WITH 2 PIECE COVERS.

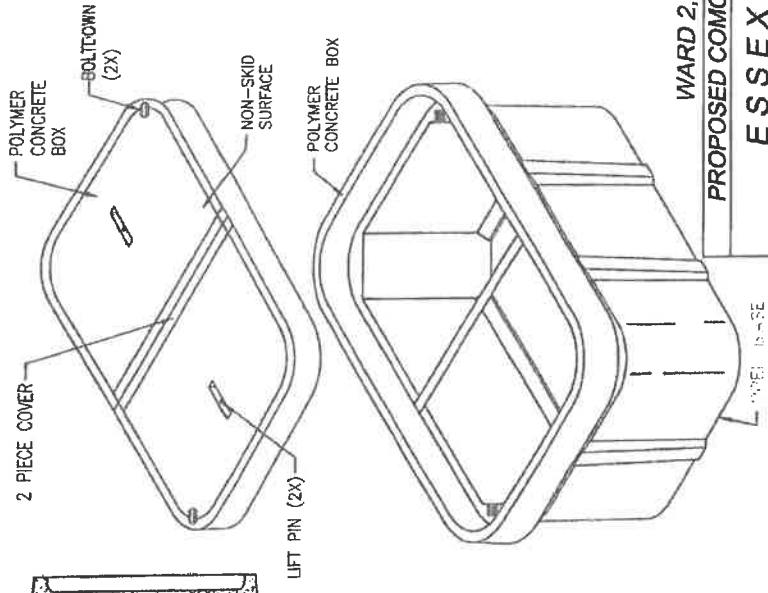

WARD 2, PRECINCT 2
PROPOSED COMCAST UNDERGROUND
ESSEX COUNTY
PLAN OF LAND
SALEM, MA

Prepared for:	COMCAST 9 FOREST ROAD, SUITE #6 WOBURN, MA 01801	Prepared By:	DEWSNAP ENGINEERING ASSOC. LLP 170 Lincoln Avenue - Salem, MA 01968 Tel: (978) 258-0395
Date:	May 24, 2021	Scale:	As Shown
Checked By:	F.D.D. & P.A.D	PROJECT LOCATION:	94 WASHINGTON STREET SALEM, MA
Drawn By:	W.A.J		
Field By:	N/A		



THIS PLAN IS DRAWN ON 11" X 17" PAPER.

PETITION OF COMCAST FOR LOCACTION FOR CONDUITS, MANHOLES AND
POLES

To the City Council for the City of Salem, Massachusetts:

Respectfully represents Comcast Cable Communications Management LLC., a company incorporated for the distribution of broadband services, that it desires to construct a line for such broadband under the public way or ways hereinafter specified.

Washington Street: Starting at the existing Comcast Manhole excavating to place (1) 4" PVC conduit 16'+/_ to a proposed 24" x 36" vault located in the sidewalk at 94 Washington Street.

Wherefore, your petition prays that, after due notice and hearing as provided by law, the City Council may by Order grant your petitioner permission to construct, and a location for, such a line of conduits, manholes and poles with the necessary wires and cables therein, said conduits manholes and poles to be located, substantially as shown on the plan made by Dewsnap Engineering dated May 24,2021 and filed here with, under the following public way or ways of said City of Salem.

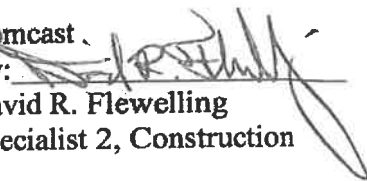
Comcast
By: 
David R. Flewelling
Specialist 2, Construction

Dated this May 25,2021

City of Salem, Massachusetts

Received and filed _____, 2021.

CITY OF SALEM



2021 MAY 18 PM 12:18

CITY CLERK
SALEM, MASS

BLOCK PARTY

May 17, 2021
(DATE)

TO THE CITY COUNCIL:

We, the undersigned residents, respectfully apply for a BLOCK PARTY license as follows:

LOCATION: Intersection of Federal, Beckford and Andover Streets in Ward 2
Federal Street Neighborhood Association Block Party

DATE: Saturday July 3, 2021

TIME: 4pm - 7pm

RAINDATE: Sunday July 4, 2021 4pm - 7pm

<u>Jane Curtis Arlander</u> (Print Name)	<u>Jane Curtis Arlander</u> (Signature of Applicant)	<u>93 Federal Street</u> (Address)	<u>978-979-7813</u> (Tel. No.)
<u>RICHARD LINDEMAN</u> (Print Name)	<u>Richard Lindeman</u> (Signature of Applicant)	<u>113 Federal St</u> (Address)	<u>978-744-5096</u> (Tel. No.)
<u>Constance Arlander</u> (Print Name)	<u>Constance Arlander</u> (Signature of Applicant)	<u>91 Federal St.</u> (Address)	<u>978-744-4619</u> (Tel. No.)

In City Council MAY 27 2021
LICENSE GRANTED

ATTEST:

CITY CLERK



CITY OF SALEM, MASSACHUSETTS
 PARK, RECREATION & COMMUNITY SERVICE
 401 Bridge Street, Salem MA 01970
 Tel. (978) 744-0180/(978) 744-0924
 pobrien@salem.com

Kimberley Driscoll
 MAYOR

Trish O'Brien
 Superintendent

Road Bike/Race/Walk/Parade Application

PLEASE SUBMIT PAYMENT OF \$200 WITH THIS PERMIT APPLICATION TO THE CITY OF SALEM PARK, RECREATION AND COMMUNITY SERVICES DEPARTMENT NO LATER THAN 45 DAYS PRIOR TO THE EVENT.
Registered Non-Profit Fee \$150
ANY FOR PROFIT EVENTS WILL REQUIRE AN ADDITIONAL 5% FROM THE REGISTRATION FEES POST EVENT.

We, the undersigned, respectfully apply for permission to host a road race/walk in the City of Salem as follows:

Applicant's Name: Tom Mistretta
 Organization Name: Wicked Running Club
 Name of Race/Walk/Parade: Miles Over the Moon
 Contact #: 978-239-4012 E-Mail Address thomasmistretta@gmail.com
 Address: PO Box 601
 City/State/Zip: Salem MA 01970
 Organization Tax Status (please include Tax ID Number): 27-1340155
 What Charities Will This Race/Walk Be Benefiting? Wicked Youth Running Fund

Approximately How Much of the Race/Walk/Parade Proceeds Will Be Donated to Each Charity(s)
50% Youth Fund, 25% Salem High School, 25% other Public H.S.
Day of Race/Walk Contact Information:

Name: Tom Mistretta Contact #: 978-239-4012
 Date of Event: 7/16/2021 ^{FRIDAY} Estimated Number of Participants: 400 or state/city approved limits
 Time of Event: 8 PM Estimated Finish Time of Event: 9:15 PM
 Start Location: Bentley School Finish Location: Bentley School
 Distance of Event: 4 miles
 Has This Event Been Held Before? Yes No

All Races/Walks/Parades Are Required to Recycle and Remove Trash.

Please Explain Your Plan (Will You Bring to North Shore Recycled Fiber on 53 Jefferson Ave, Open M-F; Bring to Your Home Curbside, or Other?) If You Have Questions about Recycling, Please Contact Julie Rose for More Information 978-619-5679

Home Curbside / Danvers

Onsite EMT/Ambulance Service (Required): TMM initial

Please Attach a Map of Route With the Following Items:

1. Race/Walk Course
2. Direction of Runners Through the Race/Walk course
3. Starting and Finishing Points
4. Meeting Points For Racers Before and After the Race/Walk
5. Last year's race financials

Certificate of Insurance Attached? X Yes ___ No

A certificate of insurance for general liability naming the City of Salem as primary additional insured for amount not less than \$1,000,000 combined single limit for injury or death or property damages (including loss of use) in any one occurrence, and \$1,000,000 general aggregate coverage. (The City of Salem reserves the right to increase coverage minimum if event presents extraordinary risk).

RELEASE & INDEMNITY AGREEMENT APPLICANT'S SIGNATURE The undersigned Sponsor, by signature below, shall defend, indemnify, and hold the City of Salem, its officers, agents and employees, harmless against all liability, loss, or expenses, including attorney's fees, and against all claims, actions or judgments based upon or arising out of damage or injury (including death) to persons or property caused by any act or omission of an act sustained in any way in connections with the performance of this event or by conditions created thereby, or based upon violation of any statute, ordinance or regulation. This contractual indemnity provision does not abrogate common law or statutory liability and indemnification to the City of Salem, but is in addition to such common law or statutory provisions.

John M. Mistretta

Date: 2-28-2021

Applicant's signature

Thomas M. Mistretta

Name of applicant

A copy of this permit will be sent to the applicant upon approval. Please call Park, Recreation & Community Services if you have any questions. 978-744-0924

CITY USE ONLY

Payment Received: _____ Date Permit Issued: _____ Date Permit Mailed to Applicant: _____

Approved By:

[Signature]

Director (Or Designee) of Salem Park, Recreation & Community Services

Capt. Mark [Signature] 5-17-21 tentative approval provided a submitted and approved plan by Board of Health.

Effective date of form: 2/8/12
Revised date of form: 1/1/18

Create a New Route

Instructions Select location: salem Massachusetts or go

Toolbar

- Draw map
- Add water
- Undo
- To start
- Out & back
- Clear all

Distance:
4.03 miles
6.49 km

Actions

- Save
- Print

The map displays a hand-drawn route in Salem, Massachusetts. The route starts at a point labeled 'Start/Finish Bentley School' near the intersection of Fort Ave and another street. It proceeds south along Fort Ave, then turns west onto Webb St, then north onto Chase St, and finally east onto Fort Ave again. Distance markers are placed along the route: 1m, 2m, 3m, and 4m. The map shows various streets including Fort Ave, Webb St, Chase St, Levee St, Northway St, Bridge St, Main St, Winter St, Oliver St, Andrew St, Bridge St, Boardman St, English St, Bessel St, Carlton St, Turner St, and White St. Landmarks such as the Witch Museum, Salem Common, and Halfide Rock are also visible. The map interface includes a toolbar with options like 'Draw map', 'Add water', 'Undo', 'To start', 'Out & back', and 'Clear all'. A distance box shows 4.03 miles and 6.49 km. Action buttons for 'Save' and 'Print' are present. The map data is attributed to ©2018 Google.

Markers:
● miles

The area shown on this map is not intended for professional use. It is provided for informational purposes only. The user assumes all responsibility for the use of the information shown on this map. The user represents the user.

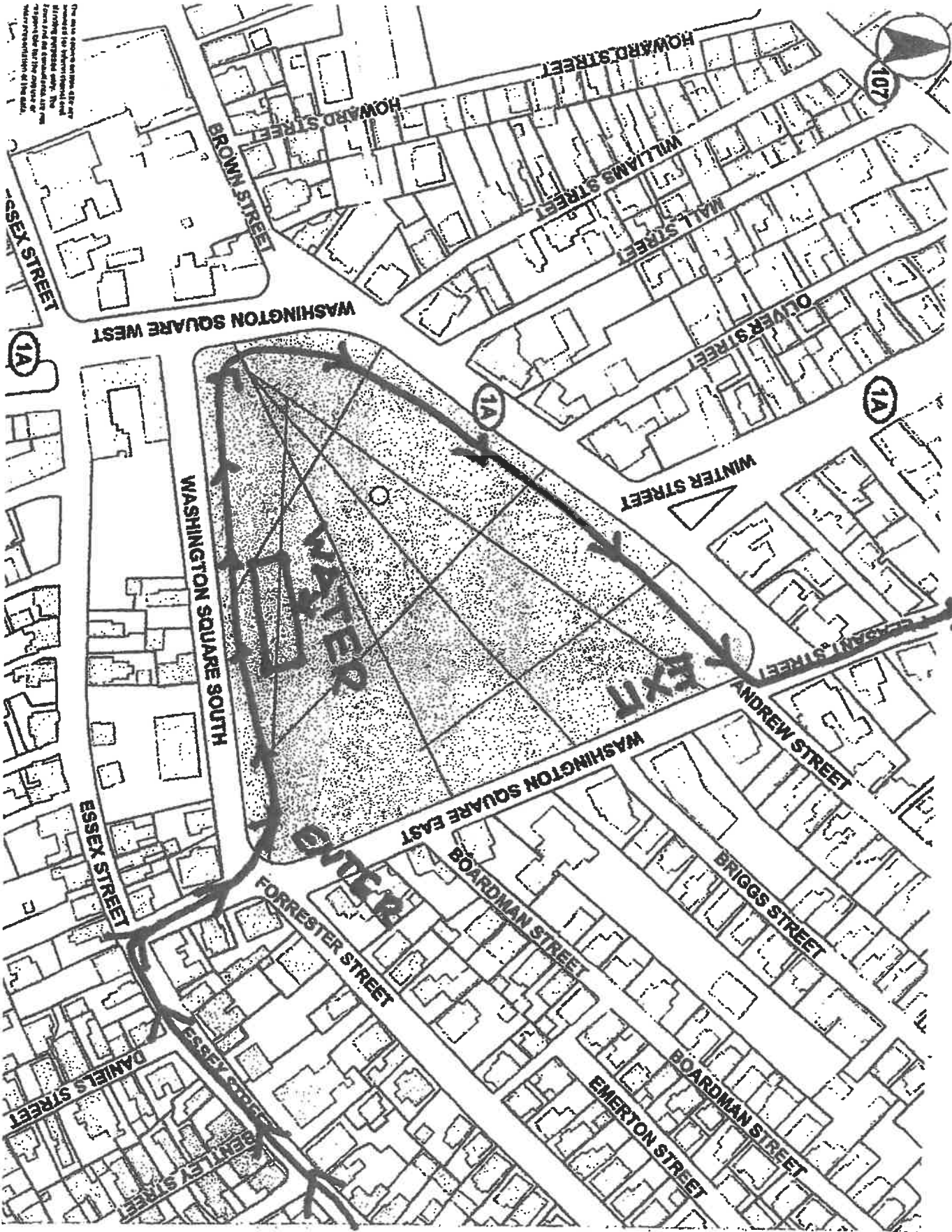

City of Salem
Parks, Recreation and Community Services
401 Bridge Street, Salem MA 01970
Attn: Joe Candelaria
March 5, 2021

Dear Parks and Recreation and Mr. Candelaria,

My name is Tom Mistretta. I am a race director and Vice President at the Wicked Running Club. I am contacting you regarding the Wicked Running Club's "Miles Over The Moon" (MOTM) running race. This race has been held in Salem for nine consecutive years, with the exception of 2020 when COVID restrictions required us to cancel. I have been Race Director for MOTM since 1995. We are most grateful for the support of the City of Salem for this race. This letter is requesting tentative permission to run the race again in Salem in 2021, specifically Friday evening, July 16, 2021.

We make this request with full understanding that at the day of submission, current COVID restrictions will not allow such a road race. This is a tentative request that is completely subject to the regulations of the State of Massachusetts and the City of Salem. We understand that this application will not proceed until which time it is clear that such requests can be reviewed by Parks and Recreation and the City of Salem. To wit, this submission is a "hold" on the date, hoping that we will be able to hold the race.

The rest of this submission describes the tentative event.

We propose to hold this race on Friday evening, July 16, 2021. The race will begin at 8PM and end around 9:15PM.

100% of the proceeds from the race go to the Wicked Youth Running Fund. This fund supports the free "Wicked Kidz" running race, an event for children which itself is also held in the City of Salem. In addition, the fund provides donations to local High School athletic programs and for academic scholarships. In 2018, the board of the Wicked Running Club voted to provide some of the proceeds to Salem's High School athletic program every year that MOTM is held in the City of Salem. This Salem donation would be in addition to any other local city or town athletic program. More details on race financials can be found later in this letter.

As per the application, you will see attached to this packet a diagram of the race through the City of Salem. The race begins and ends at the Bentley School, 25 Memorial Drive in Salem. In previous years, Ryan Monks at the Buildings and Grounds department has given his approval for us to use the school parking lot(s) for this event.

The turn-by-turn directions of the race are:

Start at Bentley School at Szetela, running East

Szetela to Memorial
Memorial to Restaurant Row at Dead Horse Beach
Restaurant Row, take Right onto Fort Ave
Fort Ave to Right on Memorial Drive
Memorial Drive to Left on Larkin, Left on Szetela
Szetela West to Essex
Essex Right to Washington Square East
Washington Square East to Left into Salem Common
Salem Common clockwise loop to Left on Pleasant
Pleasant to Right on Bridge
Bridge to Right on Osgood
Osgood to Right on East Collins St.
East Collins Street to Right on Bike Path
Bike Path to Left on Szetela running East
Finish at Bentley School

In 2019, the race financials were:

Income: \$10,189.00 Expenses: \$5,366.90 Net: \$4,822.10

Of this, \$1250 was donated to the Salem High School Track/XC Program and \$1000 was sent to Beverly High School Track/XC Program. The remainder went into the Wicked Youth Running Fund, as described above.

This entire submission includes:

- Road race application
- Acknowledgement of receipt of policy
- Salem Park, Rec, & Community Services Permit request form (for Salem Common)
- Pre-approval email from Captain Mark Losolfo
- Insurance binder

Rich Tabbut, the Treasurer of the Wicked Running Club, will send registration fees separately:

Please let me know if you have any questions. We will be monitoring the COVID restrictions and will be in touch when we see the potential for processing. Of course, please reach out to Tom Mistretta if something changes with the City.

Yours Truly

Tom Mistretta
Race Director and Vice President
Wicked Running Club

City of Salem
Parks, Recreation and Community Services
401 Bridge Street, Salem MA 01970
Attn: Joe Candelaria
March 5, 2021

Dear Parks and Recreation and Mr. Candelaria,

My name is Tom Mistretta. I am a race director and Vice President at the Wicked Running Club. I am contacting you regarding the Wicked Running Club's "Miles Over The Moon" (MOTM) running race. This race has been held in Salem for nine consecutive years, with the exception of 2020 when COVID restrictions required us to cancel. I have been Race Director for MOTM since 1995. We are most grateful for the support of the City of Salem for this race. This letter is requesting tentative permission to run the race again in Salem in 2021, specifically Friday evening, July 16, 2021.

We make this request with full understanding that at the day of submission, current COVID restrictions will not allow such a road race. This is a tentative request that is completely subject to the regulations of the State of Massachusetts and the City of Salem. We understand that this application will not proceed until which time it is clear that such requests can be reviewed by Parks and Recreation and the City of Salem. To wit, this submission is a "hold" on the date, hoping that we will be able to hold the race.

The rest of this submission describes the tentative event.

We propose to hold this race on Friday evening, July 16, 2021. The race will begin at 8PM and end around 9:15PM.

100% of the proceeds from the race go to the Wicked Youth Running Fund. This fund supports the free "Wicked Kidz" running race, an event for children which itself is also held in the City of Salem. In addition, the fund provides donations to local High School athletic programs and for academic scholarships. In 2018, the board of the Wicked Running Club voted to provide some of the proceeds to Salem's High School athletic program every year that MOTM is held in the City of Salem. This Salem donation would be in addition to any other local city or town athletic program. More details on race financials can be found later in this letter.

As per the application, you will see attached to this packet a diagram of the race through the City of Salem. The race begins and ends at the Bentley School, 25 Memorial Drive in Salem. In previous years, Ryan Monks at the Buildings and Grounds department has given his approval for us to use the school parking lot(s) for this event.

The turn-by-turn directions of the race are:

Start at Bentley School at Szetela, running East



CERTIFICATE OF LIABILITY INSURANCE

DATE (MM/DD/YYYY)
03/04/2021

THIS CERTIFICATE IS ISSUED AS A MATTER OF INFORMATION ONLY AND CONFERS NO RIGHTS UPON THE CERTIFICATE HOLDER. THIS CERTIFICATE DOES NOT AFFIRMATIVELY OR NEGATIVELY AMEND, EXTEND OR ALTER THE COVERAGE AFFORDED BY THE POLICIES BELOW. THIS CERTIFICATE OF INSURANCE DOES NOT CONSTITUTE A CONTRACT BETWEEN THE ISSUING INSURER(S), AUTHORIZED REPRESENTATIVE OR PRODUCER, AND THE CERTIFICATE HOLDER.

IMPORTANT: If the certificate holder is an ADDITIONAL INSURED, the policy(ies) must have ADDITIONAL INSURED provisions or be endorsed. If SUBROGATION IS WAIVED, subject to the terms and conditions of the policy, certain policies may require an endorsement. A statement on this certificate does not confer rights to the certificate holder in lieu of such endorsement(s).

PRODUCER Insurance Management Group 12730 Coldwater Road Suite 103 Fort Wayne IN 46845	CONTACT NAME: Margaret Mayers PHONE (A/C, No, Ext): (260) 338-2925 E-MAIL ADDRESS: mmayers@insmgt.com	FAX (A/C, No): (765) 664-0761
	INSURER(S) AFFORDING COVERAGE	
INSURED Road Runners Club of America/2021 and Its Member Clubs 1501 Lee Highway Suite 140 Arlington VA 22209	INSURER A: National Casualty Company	NAIC # 11991
	INSURER B: Nationwide Life Insurance Company	NAIC # 68869
	INSURER C:	
	INSURER D:	
	INSURER E:	
	INSURER F:	

COVERAGES **CERTIFICATE NUMBER:** 2021 \$1M A.I. **REVISION NUMBER:**

THIS IS TO CERTIFY THAT THE POLICIES OF INSURANCE LISTED BELOW HAVE BEEN ISSUED TO THE INSURED NAMED ABOVE FOR THE POLICY PERIOD INDICATED. NOTWITHSTANDING ANY REQUIREMENT, TERM OR CONDITION OF ANY CONTRACT OR OTHER DOCUMENT WITH RESPECT TO WHICH THIS CERTIFICATE MAY BE ISSUED OR MAY PERTAIN, THE INSURANCE AFFORDED BY THE POLICIES DESCRIBED HEREIN IS SUBJECT TO ALL THE TERMS, EXCLUSIONS AND CONDITIONS OF SUCH POLICIES. LIMITS SHOWN MAY HAVE BEEN REDUCED BY PAID CLAIMS.

INSR LTR	TYPE OF INSURANCE	ADDL INSD	SUBR WVD	POLICY NUMBER	POLICY EFF (MM/DD/YYYY)	POLICY EXP (MM/DD/YYYY)	LIMITS
A	<input checked="" type="checkbox"/> COMMERCIAL GENERAL LIABILITY <input type="checkbox"/> CLAIMS-MADE <input checked="" type="checkbox"/> OCCUR <input checked="" type="checkbox"/> Legal Liability to Participant \$1,000,000 GEN'L AGGREGATE LIMIT APPLIES PER: <input type="checkbox"/> POLICY <input type="checkbox"/> PRO-JECT <input type="checkbox"/> LOC <input checked="" type="checkbox"/> OTHER: Per Event Basis			KRO000008622000	12/31/2020	12/31/2021	EACH OCCURRENCE \$ 1,000,000 DAMAGE TO RENTED PREMISES (Ea occurrence) \$ 500,000 MED EXP (Any one person) \$ 5,000 PERSONAL & ADV INJURY \$ 1,000,000 GENERAL AGGREGATE \$ 5,000,000 PRODUCTS - COMP/OP AGG \$ 1,000,000 Abuse and Molestation \$ 500,000
A	AUTOMOBILE LIABILITY <input type="checkbox"/> ANY AUTO OWNED AUTOS ONLY <input checked="" type="checkbox"/> HIRED AUTOS ONLY <input checked="" type="checkbox"/> SCHEDULED AUTOS NON-OWNED AUTOS ONLY			KRO000008622000	12/31/2020	12/31/2021	COMBINED SINGLE LIMIT (Ea accident) \$ 1,000,000 BODILY INJURY (Per person) \$ BODILY INJURY (Per accident) \$ PROPERTY DAMAGE (Per accident) \$ \$
	UMBRELLA LIAB <input type="checkbox"/> OCCUR EXCESS LIAB <input type="checkbox"/> CLAIMS-MADE DED RETENTION \$						EACH OCCURRENCE \$ AGGREGATE \$ \$ PER STATUTE OTH-ER
	WORKERS COMPENSATION AND EMPLOYERS' LIABILITY ANY PROPRIETOR/PARTNER/EXECUTIVE OFFICER/MEMBER EXCLUDED? (Mandatory In NH) If yes, describe under DESCRIPTION OF OPERATIONS below		N/A				E.L. EACH ACCIDENT \$ E.L. DISEASE - EA EMPLOYEE \$ E.L. DISEASE - POLICY LIMIT \$
B	Excess Medical & Accident (\$250 Deductible/Claim)			BAX0000031541900	12/31/2020	12/31/2021	Excess Medical \$10,000 AD & Specific Loss \$2,500

DESCRIPTION OF OPERATIONS / LOCATIONS / VEHICLES (ACORD 101, Additional Remarks Schedule, may be attached if more space is required)
CERTIFICATE HOLDER IS NAMED AS AN ADDITIONAL INSURED AS RESPECTS TO THEIR INTEREST IN THE OPERATIONS OF THE NAMED INSURED. DATE OF EVENT(S): 07/16/21 Miles Over the Moon - 4 Mile Road Race INSURED RRCA CLUB/EVENT MEMBER: Wicked Running Club, Att'n: Tom Mistretta, PO Box 601, Salem, MA 01970 Attached: KRGL79
 Processed by MMM

CERTIFICATE HOLDER 07/16/21 City of Salem 93 Washington Street Salem MA 01970	CANCELLATION SHOULD ANY OF THE ABOVE DESCRIBED POLICIES BE CANCELLED BEFORE THE EXPIRATION DATE THEREOF, NOTICE WILL BE DELIVERED IN ACCORDANCE WITH THE POLICY PROVISIONS.
	AUTHORIZED REPRESENTATIVE

**Miles Over The Moon 2021 Police Department Pre-Approval**

4 messages

Thomas Mistretta <thomas.mistretta@gmail.com>
To: Mark Losolfo <mlosolfo@salempd.net>

Hi Captain Losolfo,

I trust that you have been well through these challenging times. Over here at the Wicked Running Club, we are cautiously optimistic that we may be able to return to some kind of running ever touch with Joe Candelaria at Parks and Recreation, and, while they are not processing applications at this time, he suggested that we could send in our paperwork and they would "hold" the d when I send in such paperwork I usually include a note from the Salem Police giving us their approval to hold the event. Since I realize you can't possibly give approval, I was hoping I could m with a PRE-approval, that is, pending rulings by the State of MA and the City of Salem that would allow such a race (under whatever conditions they detail i.e., number of participants, distance would support such an event.

We have chosen Friday, July 16, 2021, starting at 8PM, for the event. We would expect all runners to complete the course by 9:00PM if not sooner. The turn-by-turn directions of the event are

Route Information

Start at Bentley School at Szetela, running East
Szetela to Memorial
Memorial to Restaurant Row at Dead Horse Beach
Restaurant Row, take Right onto Fort Ave
Fort Ave to Right on Memorial Drive
Memorial Drive to Left on Larkin, Left on Szetela
Szetela West to Essex
Essex Right to Washington Square East
Washington Square East to Left into Salem Common
Salem Common clockwise loop to Left on Pleasant
Pleasant to Right on Bridge
Bridge to Right on Osgood
Osgood to Right on East Collins St.
East Collins Street to Right on Bike Path
Bike Path to Left on Szetela running East
Finish at Bentley School

And attached is an image of the race route.

Could you please respond and give your tentative pre-approval for such an event, given all the conditions I detail above?

Thanks,

Tom Mistretta
Wicked Running Club

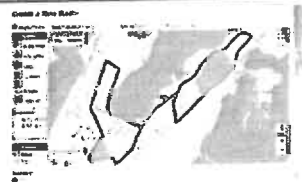

MOTM 2021 Course.png
206K

Mark Losolfo <mlosolfo@salempd.net>
To: Thomas Mistretta <thomas.mistretta@gmail.com>

Mon, Mar 1, 2021 at 8:07 AM

Hi Tom, all is well on this end and hope the same on your end. All set on our end if the Governor's orders allows for road races on July 16, 2021. It appears to be the same route as 2019 correct? If so we would need at least a week's notice to be able to hire the detail officers. Thanks.

CAPTAIN MARK LOSOLFO**95 MARGIN STREET****SALEM, MA 01970****978-744-0171 X 50261****mlosolfo@salempd.net**

From: Thomas Mistretta [thomas.mistretta@gmail.com]
Sent: Sunday, February 28, 2021 3:42 PM
To: Mark Losolfo



CITY OF SALEM, MASSACHUSETTS
PARK, RECREATION & COMMUNITY SERVICE
 401 Bridge Street, Salem MA 01970
 Tel. (978) 744-0180/(978) 744-0924
 pobrien@salem.com

Kimberley Driscoll
 MAYOR

Trish O'Brien
 Superintendent

Road Bike/Race/Walk/Parade Application

PLEASE SUBMIT PAYMENT OF \$200 WITH THIS PERMIT APPLICATION TO THE CITY OF SALEM PARK, RECREATION AND COMMUNITY SERVICES DEPARTMENT NO LATER THAN 45 DAYS PRIOR TO THE EVENT.
Registered Non-Profit Fee \$150
ANY FOR PROFIT EVENTS WILL REQUIRE AN ADDITIONAL 5% FROM THE REGISTRATION FEES POST EVENT.

We, the undersigned, respectfully apply for permission to host a road race/walk in the City of Salem as follows:

Applicant's Name: Ashley Steeves

Organization Name: B+S Fitness

Name of Race/Walk/Parade: Devils Chace 6.66 + Cnepy Clown 3.33 Road Race

Contact #: 978 594 7050 E-Mail Address: event@bnsfitness.com

Address: 10 Hemenway Rd.

City/State/Zip: Salem MA 01970

Organization Tax Status (please include Tax ID Number): NA

What Charities Will This Race/Walk Be Benefiting?
Salem Childrens Charity + Leap Education Inc,

Approximately How Much of the Race/Walk/Parade Proceeds Will Be Donated to Each Charity(s)
a minimum of \$1000

Day of Race/Walk Contact Information:

Name: Ashley Steeves Contact #: 978 594 7050

Date of Event: 10/23/21 Estimated Number of Participants: 1000

Time of Event: 8:00 AM Estimated Finish Time of Event: 10:30 AM / 11:00 AM

Start Location: Salem Willows Soccer Field Finish Location: Salem Willows Soccer Field

Distance of Event: 6.66 + 3.33 miles

Has This Event Been Held Before? Yes No

All Races/Walks/Parades Are Required to Recycle and Remove Trash.

Please Explain Your Plan (Will You Bring to North Shore Recycled Fiber on 53 Jefferson Ave, Open M-F; Bring to Your Home Curbside, or Other?) If You Have Questions about Recycling, Please Contact Julie Rose for More Information 978-619-5679

AS will remove all trash + recycling

Onsite EMT/Ambulance Service (Required): AS initial

Please Attach a Map of Route With the Following Items:

1. Race/Walk Course
2. Direction of Runners Through the Race/Walk course
3. Starting and Finishing Points
4. Meeting Points For Racers Before and After the Race/Walk
5. Last year's race financials

Certificate of Insurance Attached? Yes No

A certificate of insurance for general liability naming the City of Salem as primary additional insured for amount not less than \$1,000,000 combined single limit for injury or death or property damages (including loss of use) in any one occurrence, and \$1,000,000 general aggregate coverage. (The City of Salem reserves the right to increase coverage minimum if event presents extraordinary risk).

RELEASE & INDEMNITY AGREEMENT APPLICANT'S SIGNATURE The undersigned Sponsor, by signature below, shall defend, indemnify, and hold the City of Salem, its officers, agents and employees, harmless against all liability, loss, or expenses, including attorney's fees, and against all claims, actions or judgments based upon or arising out of damage or injury (including death) to persons or property caused by any act or omission of an act sustained in any way in connections with the performance of this event or by conditions created thereby, or based upon violation of any statute, ordinance or regulation. This contractual indemnity provision does not abrogate common law or statutory liability and indemnification to the City of Salem, but is in addition to such common law or statutory provisions.

Ashley Steves Date: 2/4/21
Applicant's signature

Ashley Steves
Name of applicant

A copy of this permit will be sent to the applicant upon approval. Please call Park, Recreation & Community Services if you have any questions. 978-744-0924

CITY USE ONLY
Payment Received: _____ Date Permit Issued: _____ Date Permit Mailed to Applicant: _____

Approved By: [Signature] 5-17-21
Director (Or Designee) of Salem Park, Recreation & Community Services

Capt. Ash Taylor 5-17-21 * Tentative approval provided a plan submitted and approved by Health Dept.
Salem Police Department

Effective date of form: 2/8/12
Revised date of form: 1/1/18

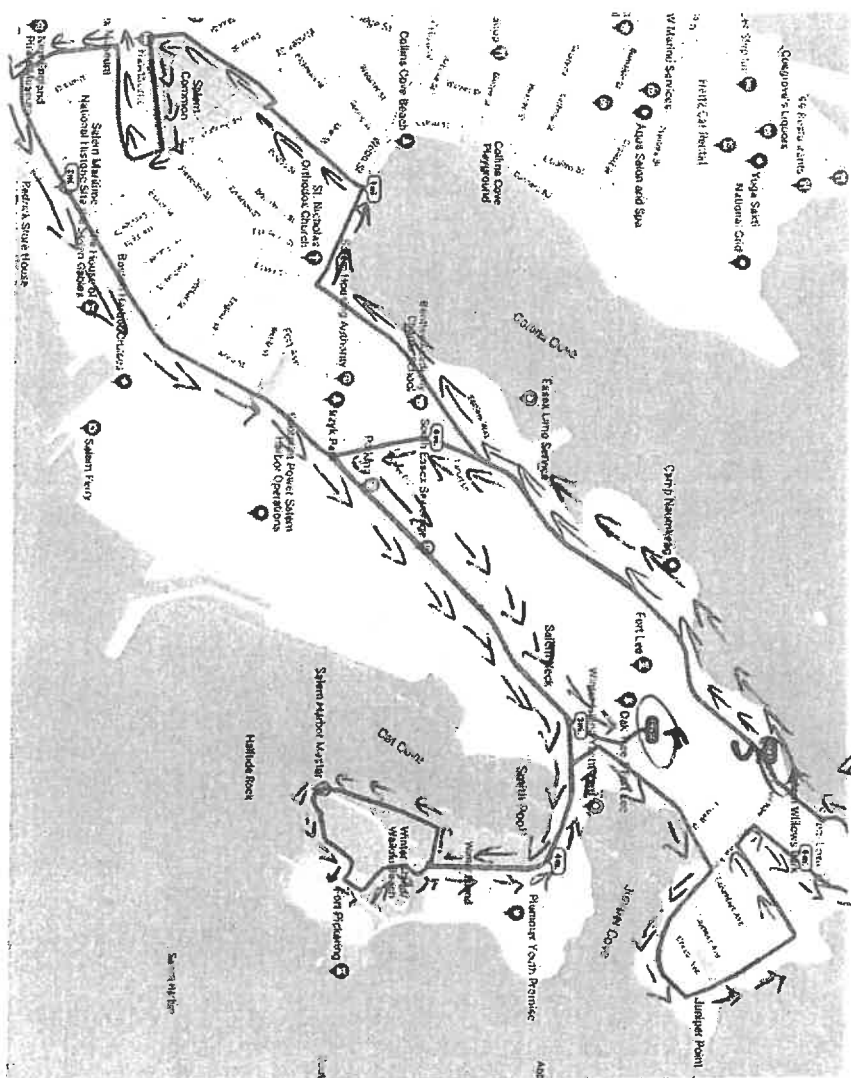

*Runners go by street to come like
a loop around memorial dr*

6.66 Turn by Turn

- Start on Restaurant Row by Tennis Courts
- Straight down Memorial Dr
- Straight on Sateela Ln
- Right on Walking Path before Webb St
- Left on Andrew St
- Enter the Salem Common on Washington Sq E
- Run counter clockwise around the Salem Common
- Exit the Common at S Washington Sq on to Forester St
- Right on to Essex St
- Left on to Little Hawthorne Blvd
- Left on to Darby St
- Straight Down Darby St
- Bare right on Winter Island Rd.
- Follow cross country trail around Winter Island, by Hamonmaster, behind the function hall, by Dave's office, left heading back out of parking lot, and keep right of check in house to exit WI.
- Right on Columbus Sq.
- Proceed down Columbus Ave
- Right on Bay View Ave
- Left on Beach Ave
- Left on Sutton Ave
- Right on to Bay View Ave
- Right on to Willow Access Road
- Follow walking path around the backside of the Willows by the yacht club
- Exit back on to Restaurant Row
- Follow straight up Memorial Dr
- Bare right at Sateela Ln, to stay on Memorial Dr
- Left on to Fort Ave
- Left on to Memorial Drive by Soccer field to FINISH

2019 approved course

*10 ways out
10 ways back*

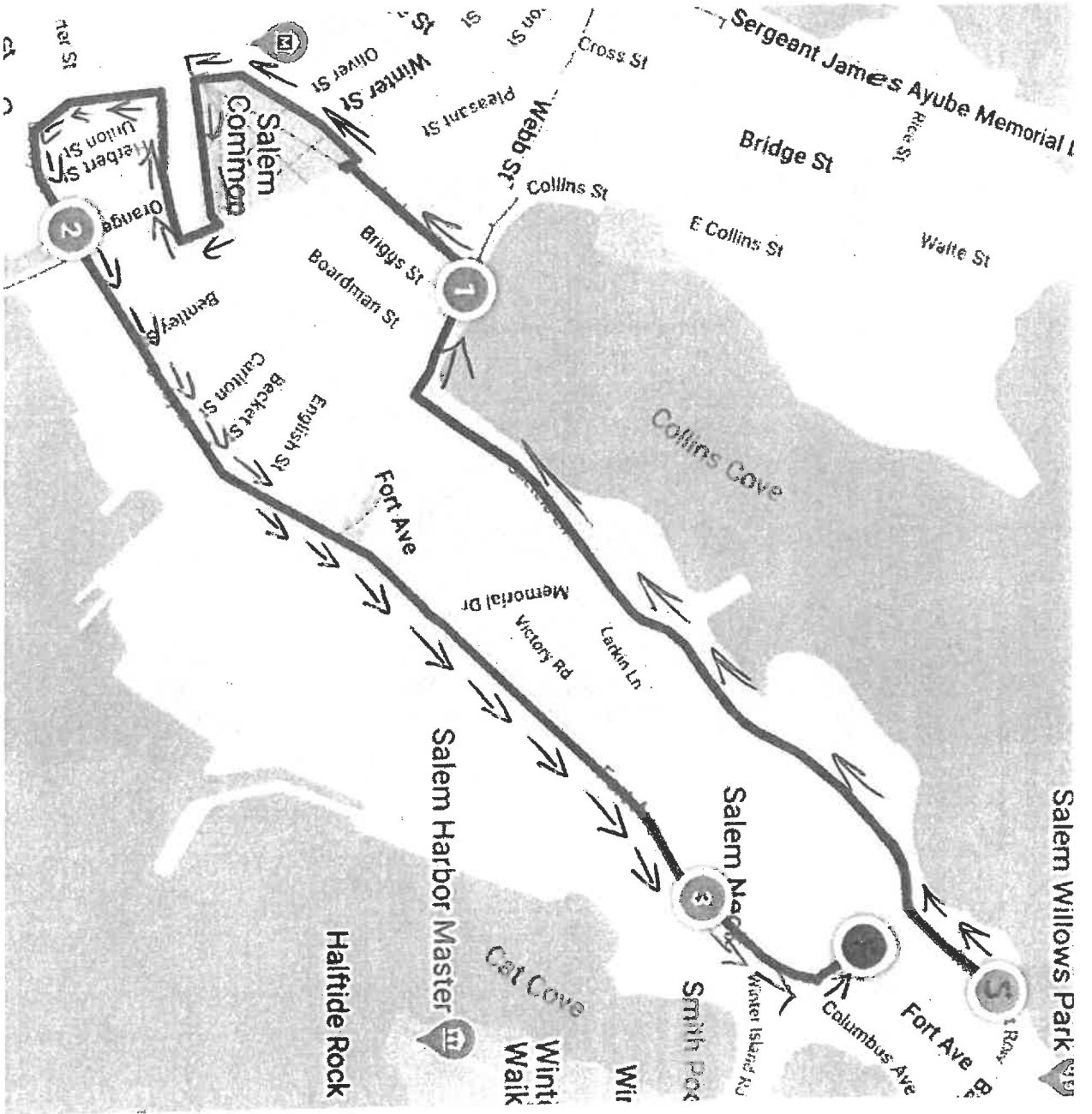

Creepy Clown
Turn by Turn 3.33

- Start on Fort Ave at Memorial Dr.
- Straight down Memorial Dr
- Straight on Szevela Ln
- Right on Walking Path before Webb St
- Left on Andrew St
- Enter the Salem Common on Washington Sq E
- Run counter clockwise around the Salem Common
- Exit the Common at S Washington Sq on to Forrester St
- Right on to Essex St
- Left on to Little Hawthorne Blvd
- Left on to Derby St
- Straight Down Derby St
- Continue down Fort Ave
- Left on to Memorial Dr by Soccer Field to FINISH

away at
away back
2019 sponsored car



CERTIFICATE OF LIABILITY INSURANCE

DATE (MM/DD/YYYY)
02/05/21

THIS CERTIFICATE IS ISSUED AS A MATTER OF INFORMATION ONLY AND CONFERS NO RIGHTS UPON THE CERTIFICATE HOLDER. THIS CERTIFICATE DOES NOT AFFIRMATIVELY OR NEGATIVELY AMEND, EXTEND OR ALTER THE COVERAGE AFFORDED BY THE POLICIES BELOW. THIS CERTIFICATE OF INSURANCE DOES NOT CONSTITUTE A CONTRACT BETWEEN THE ISSUING INSURER(S), AUTHORIZED REPRESENTATIVE OR PRODUCER, AND THE CERTIFICATE HOLDER.

IMPORTANT: If the certificate holder is an ADDITIONAL INSURED, the policy(ies) must be endorsed. If SUBROGATION IS WAIVED, subject to the terms and conditions of the policy, certain policies may require an endorsement. A statement on this certificate does not confer rights to the certificate holder in lieu of such endorsement(s).

PRODUCER CURTIS J. VERNON INSURANCE AGENCY PO BOX 266 BOUNTIFUL, UT 84010	CONTACT NAME:		FAX (A/C. No.):	(801) 677-0077
	PHONE (A/C. No. Ext.):	(801) 292-5529		
	E-MAIL ADDRESS:			
	INSURER(S) AFFORDING COVERAGE		NAIC#	
	INSURER A:	UNDERWRITERS AT LLOYD'S, LONDON		32727
	INSURER B:			
	INSURER C:			
	INSURER D:			
	INSURER E:			
	INSURER F:			

INSURED **B&S FITNESS PROGRAMS LLC**
45 CONGRESS STREET, DOCK 19-20
SALEM, MA 01970

COVERAGES CERTIFICATE NUMBER: REVISION NUMBER:

THIS IS TO CERTIFY THAT THE POLICIES OF INSURANCE LISTED BELOW HAVE BEEN ISSUED TO THE INSURED NAMED ABOVE FOR THE POLICY PERIOD INDICATED. NOTWITHSTANDING ANY REQUIREMENT, TERM OR CONDITION OF ANY CONTRACT OR OTHER DOCUMENT WITH RESPECT TO WHICH THIS CERTIFICATE MAY BE ISSUED OR MAY PERTAIN, THE INSURANCE AFFORDED BY THE POLICIES DESCRIBED HEREIN IS SUBJECT TO ALL THE TERMS, EXCLUSIONS AND CONDITIONS OF SUCH POLICIES. LIMITS SHOWN MAY HAVE BEEN REDUCED BY PAID CLAIMS.

INSR LTR	TYPE OF INSURANCE	ADUL INSP	SUBR WVD	POLICY NUMBER	POLICY EFF (MM/DD/YYYY)	POLICY EXP (MM/DD/YYYY)	LIMITS
A	<input checked="" type="checkbox"/> COMMERCIAL GENERAL LIABILITY <input type="checkbox"/> CLAIMS-MADE <input checked="" type="checkbox"/> OCCUR	Y		MSJ0427789128	02/01/21	02/01/22	EACH OCCURRENCE \$ 1,000,000
	GEN'L AGGREGATE LIMIT APPLIES PER: <input checked="" type="checkbox"/> POLICY <input type="checkbox"/> PRO-JECT <input type="checkbox"/> LOC OTHER:						DAMAGE TO RENTED PREMISES (Ea occurrence) \$ 100,000
	AUTOMOBILE LIABILITY ANY AUTO ALL OWNED AUTOS <input type="checkbox"/> SCHEDULED AUTOS <input type="checkbox"/> HIRED AUTOS <input type="checkbox"/> NON-OWNED AUTOS <input type="checkbox"/>						MED EXP (Any one person) \$ 5,000
	UMBRELLA LIAB <input type="checkbox"/> OCCUR EXCESS LIAB <input type="checkbox"/> CLAIMS-MADE						PERSONAL & ADV INJURY \$ 1,000,000
	DED RETENTIONS						GENERAL AGGREGATE \$ 3,000,000
	WORKERS COMPENSATION AND EMPLOYERS' LIABILITY ANY PROPRIETOR/PARTNER/EXECUTIVE OFFICER/MEMBER EXCLUDED? (Mandatory in NH) If yes, describe under DESCRIPTION OF OPERATIONS below		Y/N				PRODUCTS - COMP/OP AGG \$ 2,000,000 Professional Liability \$ 3,000,000
A	PHYSICAL AND/OR SEXUAL ABUSE LIABILITY			MSJ0427789128	02/01/21	02/01/22	COMBINED SINGLE LIMIT (Ea accident) \$ BODILY INJURY (Per person) \$ BODILY INJURY (Per accident) \$ PROPERTY DAMAGE (Per accident) \$ EACH OCCURRENCE \$ AGGREGATE \$
							PER STATUTE <input type="checkbox"/> OTH-ER <input type="checkbox"/> E.L. EACH ACCIDENT \$ E.L. DISEASE - EA EMPLOYEE \$ E.L. DISEASE - POLICY LIMIT \$
							OCCURENCE: \$100,000 AGGREGATE: \$300,000

DESCRIPTION OF OPERATIONS / LOCATIONS / VEHICLES (ACORD 101, Additional Remarks Schedule, may be attached if more space is required)

SPECIAL EVENT CERTIFICATE
Event: Wild Fish Open Water Swim
Date: 8/7/2021
Certificate holder is named as additional insured.

CERTIFICATE HOLDER City of Salem 93 Washington Street Salem MA 01970	CANCELLATION SHOULD ANY OF THE ABOVE DESCRIBED POLICIES BE CANCELLED BEFORE THE EXPIRATION DATE THEREOF, NOTICE WILL BE DELIVERED IN ACCORDANCE WITH THE POLICY PROVISIONS. AUTHORIZED REPRESENTATIVE
--	---

City of Salem

In the year Two Thousand and Twenty One

An Ordinance to amend an ordinance relative to accessory dwelling units.

Be it ordained by the City Council of the City of Salem, as follows:

Section 1. The City of Salem Zoning Ordinance Section 3. Table of Principal and Accessory Use Regulations is hereby amended by deleting the use entitled Accessory Living Area and adding the following new uses within Section E Accessory Uses:

E. ACCESSORY USES	RC	R1	R2	R3	B1	B2	B4	B5	I	BPD	NRCC
Affordable Accessory Dwelling Unit attached to a Principal Dwelling (as defined in Sec 3.2.8) or within a Principal Dwelling.	Y	Y	Y	Y	N	N	N	N	N	N	Y
Affordable Accessory Dwelling Unit within an Existing Detached Accessory Building, as defined in Sec 3.2.8	Y	Y	Y	Y	N	N	N	N	N	N	Y

Section 2. Section 10 Definitions is hereby amended by deleting the definition “Accessory Living Area” in its entirety and inserting the definition “Affordable Accessory Dwelling Unit” as follows:

“Affordable Accessory Dwelling Unit: A housekeeping unit with a maximum rent at least 30 percent below the United States Department of Housing and Urban Development (HUD) fair market rent limit for Salem, with its own sleeping, cooking and sanitary facilities, located either in a detached accessory building, or within or attached to a principal dwelling and subordinate in size to the principal unit(s), separated from it in a manner which maintains the appearance of the principal unit(s), and allowed pursuant to Section 3.2.8 of this ordinance.”

Section 3. Section 3.2.4 Accessory Buildings and Structures is hereby amended by deleting paragraph 4 in its entirety and replacing it with the following new paragraphs 4, 5 and 6 as follows:

“4. Accessory structures, garages and detached affordable accessory dwelling units shall not exceed one and one-half (1.5) stories or eighteen (18) feet in height.

5. Detached affordable accessory dwelling units shall comply with all regulations set forth in Section 3.2.4 (Accessory Buildings and Structures) of this Ordinance with the exception of setbacks, which shall comply with Section 3.2.4(6).

6. Detached affordable accessory dwelling units shall comply with all setbacks of the principal structure, as set forth in Section 4.1 of this ordinance (Dimensional Requirements), irrespective of whether the principal structure on the property in question complies with such setbacks or not, unless otherwise permitted by a Special Permit pursuant to subsection 3 of Section 3.2.8.”

Section 4. Section 3.2.8 Accessory Dwelling Areas is hereby amended by deleting Section 3.2.8 in its entirety and replacing it with the following:

“3.2.8 Affordable Accessory Dwelling Units. Affordable Accessory Dwelling Units shall be allowed as provided set forth in this section.

1. Purpose.

- A. To add affordable rental units to the housing stock to meet the needs of smaller households and make housing units available to households who might otherwise have difficulty finding housing.
- B. To encourage the efficient use of the city's housing supply while preserving the character of the city's neighborhoods.
- C. To maximize privacy, dignity, and independent living among family members preserving domestic family bonds as well as to protect the stability, property values, and the residential character of the neighborhood.
- D. To permit the owner of an existing, or a proposed, principal dwelling to construct one additional affordable dwelling unit per principal dwelling. Such a use is incidental and subordinate in size to the principal dwelling.
- E. To increase the supply of housing and the diversity of housing options, in response to demographic changes such as smaller households and older households.

2. Procedure.

- A. The Building Inspector shall administer and enforce the provisions of this section.

3. Special Permit. Pursuant to Section 9.4, in the interests of design flexibility and overall project quality, the Zoning Board of Appeals may grant a Special Permit for the following:

- A. An existing detached accessory building as defined in subsection 8 of Section 3.2.8 that is not in compliance with the setbacks of the principal dwelling unit.
- B. An expanded detached accessory building as defined in subsection 8 of Section 3.2.8.

4. Application.

A. The Application for the Building Permit, shall:

1. Be signed by one hundred (100) percent of the record title ownership interest of the principal dwelling and shall include a copy of the deed and in the case of a property held by a condominium trust, all owners of all units within the condominium.

2. Include a floor plan of the affordable accessory dwelling unit, the principal dwelling where it is to be located and all elevations. All plans shall be drawn to scale and identify the existing structure and proposed modifications to create the affordable accessory dwelling unit.
3. Be accompanied by a letter of intent signed by the homeowner(s) and shall be submitted to the Department of Planning and Community Development that certifies the rent of the accessory dwelling unit will be at least 30 percent below the established fair market rent limit determined by the United States Department of Housing and Urban Development.

5. Requirements.

- A. The maximum rent of the affordable accessory dwelling unit, including utilities and parking, shall be at least thirty percent below the established Fair Market Rent limit for the City of Salem as determined annually by the United States Department of Housing and Urban Development.
- B. The affordable accessory dwelling unit shall not be constructed within a new detached accessory building, as defined in subsection 8 of Section 3.2.8.
- C. The affordable accessory dwelling unit shall not be considered a dwelling unit for the purpose of Section 5.1 Required Parking.
- D. The affordable accessory dwelling unit shall not result in a net loss of the total measured caliper inches of private trees on the lot in which the affordable accessory dwelling unit will be located unless a payment in per caliper inch of the tree diameter at breast height (DBH) at the prevailing rate set by the Tree Warden is made to the tree replacement fund.
- E. The affordable accessory dwelling unit shall not contain less than 350 square feet of habitable space.
- F. The affordable accessory dwelling unit shall not contain in excess of 900 square feet of habitable space.
- G. The affordable accessory dwelling unit shall not exceed 50% of the gross floor area of the principal dwelling.
- H. No more than one (1) affordable accessory dwelling unit shall be permitted for each principal dwelling unit and at least one (1) owner of the residence in which the affordable accessory dwelling unit is created shall reside in one (1) of the dwelling units, either the principal or accessory unit created therein, as a principal place of residence. For the purpose of this section, the "owner" shall be one or more individuals who hold title to the property, or a purchase and sales agreement and for whom the dwelling shall be the primary residence as evidenced by voter registration, tax return or other documentation demonstrating primary residence. Owner occupancy is required for an affordable accessory dwelling unit to be permitted.
- I. An affordable accessory dwelling unit shall not be permitted in a building with five (5) or more units.
- J. Electricity, water, oil and gas shall be provided by a single service to both the affordable accessory dwelling unit and the principal dwelling, and included in the rent.
- K. The affordable accessory dwelling unit may not be sold or transferred separate and apart from the principal dwelling to which it is an accessory use. The principal dwelling and the accessory dwelling unit shall remain in common or single ownership and shall not be severed in ownership.
- L. All stairways to the affordable accessory dwelling unit above the first floor shall be located on the rear or side of the dwelling.

- M. The affordable accessory dwelling unit shall not contain more than two (2) bedrooms.
- N. The affordable accessory dwelling unit shall be clearly subordinate in use, size and design to the principal dwelling.
- O. The affordable accessory dwelling unit must be capable of being discontinued as a separate dwelling unit without demolition of any structural component of the principal dwelling.
- P. There shall be no occupancy of the affordable accessory dwelling unit until the Building Inspector has issued a certificate of occupancy that the principal dwelling and affordable accessory dwelling unit are in compliance with all applicable health and building codes.
- Q. The Building Permit shall be revoked upon determination by the Building Inspector that any condition imposed by Section 3.2.8 has not been fulfilled.
- R. By filing the Application for a Building Permit for an affordable accessory dwelling unit, all owners consent to an inspection without a warrant upon reasonable notice by the Building Inspector to ensure compliance with all terms of this section.
- S. Short term rentals, as defined in Salem Code of Ordinances Chapter 15, are prohibited in the accessory dwelling unit.
- T. The affordable accessory dwelling unit shall obtain a certificate of fitness subject to the provisions of Section 2-705 of the City of Salem Code of Ordinances.

6. Termination.

- A. The affordable accessory dwelling unit use shall terminate immediately upon any violation of any term or condition of this ordinance that the owner fails to cure, upon thirty (30) days written notice mailed to the applicant and to the occupants at the dwelling address by certified mail, return receipt requested.
- B. Duty of Owner Upon Termination include:
 - a. The owner shall discontinue the use of the affordable accessory dwelling unit as a separate dwelling unit.
 - b. The kitchen facilities of the affordable accessory dwelling unit shall be removed unless determined by the Building Inspector to be incidental and subordinate as an accessory use of the principal dwelling.
 - c. Any additional exterior entrance constructed to provide access to the accessory dwelling unit shall be permanently closed, unless the Building Inspector provides a waiver. The owner shall permit an inspection by the Building Inspector without a warrant.

7. Severability. All the clauses of this ordinance are distinct and severable, and if any clause shall be deemed illegal, void, or unenforceable, it shall not affect the validity, legality, or enforceability of any other clause or portion of this bylaw."

8. Definitions.

Attached affordable accessory dwelling unit: An affordable accessory dwelling unit created by adding gross floor area to the principal dwelling after the adoption of this ordinance.

Existing detached accessory building: A detached accessory building that is existing as of the effective date of this ordinance, that has a foundation, and is a minimum of 350 square feet.

Expanded detached accessory building: An existing detached accessory building that is expanded after the effective date of this ordinance.

New detached accessory building: A detached accessory building that is not existing as of the effective date of this ordinance.

Principal dwelling unit: A dwelling unit permitted as a principal residential use under Section 3, Table of Principal and Accessory Use Regulations. By way of example a single-family home permitted pursuant to Section 3 shall comprise of one principal dwelling unit, whereas a two-family home permitted pursuant to Section 3 shall comprise of two principal dwelling units. An accessory dwelling unit shall not be considered a principal dwelling unit.

Section 5. This Ordinance shall take effect as provided by City Charter.

In City Council February 11, 2021

Referred to the Planning Board to hold a Joint Public Hearing by a roll call vote of 11 yeas, 0 nays and 0 absent

Joint Public Hearing Held on March 30, 2021

Advertised in the Salem News on March 15, 2021 and March 22, 2021

Joint Public Hearing Closed by a roll call vote of 11 yeas, 0 nays and 0 absent

Referred to the Planning Board for their review and recommendation by a roll call vote of 11 yeas, 0 nays and 0 absent

In City Council April 8, 2021

Referred to the Committee on Ordinances, Licenses and Legal Affairs co-posted with the Committee of the Whole and invite the Zoning Enforcement Officer

In City Council April 22, 2021

Motion to strike section to allow one (1) affordable accessory dwelling unit per dwelling unit was denied by a roll call vote of 4 yeas, 7 nays and 0 absent

Adopted as amended for first passage as amended by a roll call of 7 yeas, 4 nays and 0 absent

In City Council May 13, 2021

Motion to refer the matter back to the Committee on Ordinances, Licenses and Legal Affairs coposted with the Committee of the Whole was defeated by a roll call vote of 4 yeas, 7 nays and 0 absent

Motion to Lay it on the table passed by a roll call vote of 11 yeas, 0 nays and 0 absent

ATTEST:

ILENE SIMONS
CITY CLERK

City of Salem

In the year two thousand and twenty one

An Ordinance to amend an Ordinance relative to outdoor cooking appliances, heating equipment and fireplaces.

Be it ordained by the City Council of the City of Salem, as follows:

Section I. Article III *Fire Prevention Code* of Chapter 20 of the Code of Ordinances is hereby amended by deleting Sec. 20 -129 in its entirety and replacing it with the following:

"Sec. 20 -129. – Use of solid fuel outdoor patio and space heaters, outdoor decorative heating appliances and outdoor fireplaces within the city.

- a. Unless otherwise provided herein, it is prohibited within the city to use any outdoor patio or space heater, decorative heating appliance such as a chiminea, fire pit or outdoor fireplace using solid fuel including charcoal, wood, fuel pellets or any non-gaseous fuel.

- b. Solid fuel campfires shall be permitted at Winter Island Campground within the confines of the entire park beginning at the main entrance security gate, but not including the beach, walkway leading to the beach or within the confines of historic Fort Pickering. Campfires are permitted under the following conditions:
 - (1) No campfire shall be permitted in any location on Winter Island other than designated campsites. All fires must be within a proper firepit no larger than 30 inches. Campfires must be kept small and always remain within the designated firepit.
 - (2) Bon fires are not permitted.
 - (3) Only clean, untreated, and non-contaminated wood may be burned. No construction debris, composite materials, paper, household waste, rubber, plastic, leaves, pressure treated or painted wood may be burned.
 - (4) Solid fuel/wood may be sold by Winter Island staff.
 - (5) No accelerants such as gasoline, oil, or kerosene may be used.
 - (6) All campfires must be supervised at all times by and adult 18 years and older.
 - (7) No campfires are allowed prior to 5 p.m. and all fires must be extinguished by 11:30 p.m.
 - (8) The Winter Island Manager may establish and enforce rules and regulations governing campfires within the designated campsites on Winter Island.

- c. Fire officials and the Winter Island Manager or their designees are authorized to enforce this ordinance."

Section II. This Ordinance shall take effect as provided by City Charter.

In City Council May 13, 2021

Adopted for first passage by a roll call vote of 11 yeas, 0 nays and 0 absent

In City Council May 27, 2021

ATTEST:

ILENE SIMONS
CITY CLERK

City of Salem

In the year Two Thousand and Twenty One

An Ordinance to amend an Ordinance relative to Traffic Ch. 42, Sec. 50B,
"Handicapped Zones, Limited Time"

Be it ordained by the City Council of the City of Salem, as follows:

Section I. Amending Chapter 42, Section 50B – "Handicapped Zones, Limited Time" is hereby amended by adding the following:

Orne Street – One Handicapped Parking Space to be added in front of #44 Orne Street, for the distance of twenty (20) feet.

Section II. This Ordinance shall take effect as provided by City Charter.

In City Council May 13, 2021

Adopted for first passage by a roll call vote of 11 yeas, 0 nays and 0 absent

In City Council May 27, 2021

ATTEST:

ILENE SIMONS
CITY CLERK

CITY OF SALEM

In the year Two Thousand and Twenty One

An Ordinance Relative to Traffic

Be it ordained by the City Council of the City of Salem, as follows:

Section 1. Section 51 of Article V shall be amended by repealing the following:

Fort Avenue – Parking Prohibited on Certain Streets – from Bay View Avenue to Island Road southeasterly side.

Section 2. Section 51 of Article V shall be further amended by adding the following:

Memorial Drive – Parking Prohibited on Certain Streets – southwesterly side between Restaurant Row and Fort Avenue.

Section 3. Section 51B of Article V shall be amended by repealing the following:

Fort Avenue – Parking Prohibited at Certain Times on Certain Streets – both sides between Memorial Drive and Columbus Avenue. Two (2) hour parking).

Fort Avenue – Parking Prohibited at Certain Times on Certain Streets – southerly side, at the intersection of Bayview Avenue and running in an easterly direction for a distance of five hundred and ninety (590) feet. Fifteen (15) minute parking.

Section 4. Section 56 of Article V shall be amended by adding the following:

Fort Avenue – Parking Meter Zones Established – southeasterly side beginning at Bay View Avenue for a distance of five hundred ninety (590) feet. Two (2) hour parking. April 1 to October 31. Monday through Sunday, 8:00am to 8:00pm.

Section 5. Section 75 of Article V-A shall be amended by repealing the following:

Fort Avenue – Parking Prohibitions Towing Zone (Resident Sticker) – ZONE A, COLOR BLUE, in a northerly direction, from Columbus Avenue to Bay View Avenue. Resident Sticker Parking, Tow Zone.

And replacing it with:

Fort Avenue – Parking Prohibitions Towing Zone (Resident Sticker) – ZONE A, COLOR BLUE, from Columbus Avenue to Bay View Avenue, southeasterly side. Resident Sticker Parking, Tow Zone.

Section 6. This ordinance shall take effect as provided by City Charter.

In City Council May 13, 2021

Adopted for first passage by a roll call vote of 11 yeas, 0 nays, 0 absent

In City Council May 27, 2021

ATTEST:

ILENE SIMONS
CITY CLERK