

ORDER FOR LOCATION FOR TELECOMMUNICATIONS WIRES AND WIRELESS ATTACHMENTS AND APPURTENANCES

By the City Council

Of the City of Salem, Massachusetts, _____, 2019

ORDERED:

That pursuant to Massachusetts General Laws, Chapter 166, NEW CINGULAR WIRELESS PCS, LLC ("AT&T") is hereby granted locations for and permission to construct and maintain telecommunications wires and wireless attachments and appurtenances, including fiber optic cable(s), remote nodes and pole top antennas, to be attached to existing National Grid utility poles, located upon, along and under the public ways within the City of Salem, as substantially shown on the plans filed with said Petition. In addition, AT&T is hereby granted permission to install conduit or direct bury fiber cable(s) as depicted on the plans submitted.

The forgoing permission is subject to the following conditions:

1. The telecommunications wires and wireless attachments and appurtenances shall be installed and operated in compliance with all applicable federal and state laws and regulations.
2. AT&T shall indemnify and save the City harmless against all damages, costs and expense whatsoever to which the City may be subjected in consequence of the acts or neglect of AT&T or its agents or servants, or in any manner arising from the rights and privileges granted by the City.
3. AT&T shall comply with the requirements of existing City Ordinances, as may be applicable and such as may hereafter be adopted governing the construction and maintenance of said telecommunications wires and wireless attachments and appurtenances, so far as the same are not inconsistent with the laws of the United States or of the Commonwealth of Massachusetts.

I hereby certify that the foregoing was adopted at a meeting of the City Council of the City of Salem, Massachusetts, held on the _____ day of _____, 2019.

City Clerk

APPROVED

We hereby certify that on _____, 2019, at _____, o'clock at _____, a public hearing was held on the Petition of NEW CINGULAR WIRELESS PCS, LLC ("AT&T") for permission to construct and maintain telecommunications wires and wireless attachments and appurtenances, including fiber optic cable(s), remote nodes and pole top antennas, to be attached to existing utility poles, located upon, along and under the public ways within the City of Salem and to install conduit or direct bury fiber cable(s) as indicated in the plans described in the order herewith recorded, that we mailed at least seven days before said hearing a written notice of the time and place of said hearing to each of the owners of real estate (as determined by the last preceding assessment for taxation) along the ways or parts of ways upon which the Company is permitted to construct the telecommunications wires and appurtenances of AT&T under said order, and that thereupon said order was duly adopted.

City Council of the City of Salem

CERTIFICATE

I hereby certify that the forgoing is a true copy of a grant of location order and certificate of hearing with notice adopted by the City Council of the City of Salem, Massachusetts, on the _____ day of _____, 2019, and recorded with records of location orders of said City, Book _____, Page _____. This certified copy is made under the provisions of Chapter 166 of the Massachusetts General Laws, as amended.

Attest:

City Clerk

APPROXIMATE COORDINATES: LAT: 42.531510° N LONG: 70.905330° W



CENTERLINE
750 WEST CENTER STREET
SUITE #301
WEST BRIDGEWATER, MA 02379

H2G HUDSON
Design Group LLC

NO.	REV.	DESCRIPTION	BY

CHECKED BY: AT
APPROVED BY: DJC

SUBMITTALS

NO.	REV.	DESCRIPTION	BY

CLIENT AND SITE NUMBER:
AREA4_0157A

SITE ID:
AREA4_0157A

SITE ADDRESS:
40 LIBERTY HILL AVE
SALEM, MA 01970
ESSEX COUNTY

SHEET TITLE:
KEY PLAN AND ELEVATION

SHEET NUMBER:
A-1

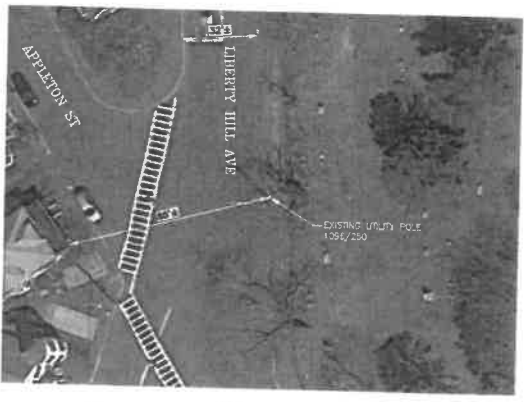

KEY PLAN
22x34 SCALE: 1/4"=20'
11x17 SCALE: 1/4"=40'

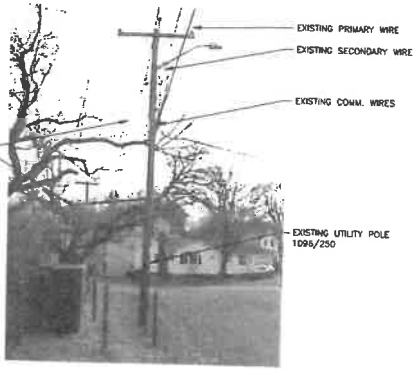

EXISTING CONDITIONS PHOTO DETAIL
SCALE: N.T.S.

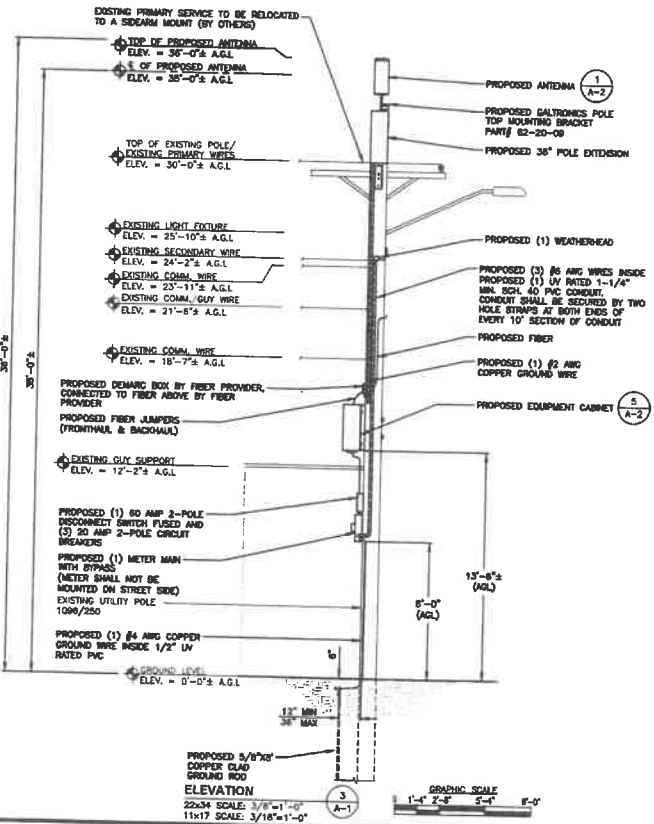

GRAPHIC SCALE
1"=4' 2"=8' 5"=4' 8"=0'

CHECKED BY: AT

APPROVED BY: DJC

SUBMITTALS

NO.	DESC.	QUANTITY	DATE
1	PROPOSED ANTENNA	1	
2	PROPOSED RRH	2	
3	PROPOSED DIPLEXER	1	
4	PROPOSED ANTENNA MOUNT	1	
5	PROPOSED EQUIPMENT CABINET	1	

OWNER AND H2G NUMBER:
AREA4_0157A

REV. ID:
AREA_M_0157A

REV. APPROVED:
40 LIBERTY HILL AVE
SALEM, MA 01970
ESSEX COUNTY

SHEET TITLE
EQUIPMENT DETAILS

SHEET NUMBER
A-2

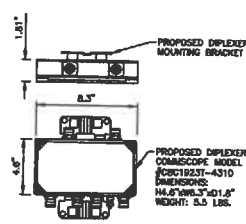
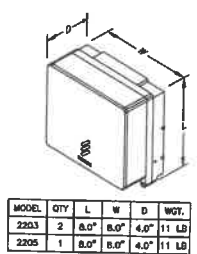
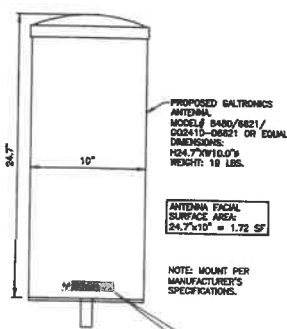

RRH DETAIL
SCALE: N.T.S.

DIPLEXER DETAIL (AS REQUIRED)
SCALE: N.T.S.



H01-CD-18 1"x6" NOTICE DECAL. PLACE THREE NOTICE STICKERS EQUALLY SPACED AROUND THE BOTTOM OF ANTENNA RADOME.

ANTENNA DETAIL
SCALE: N.T.S.

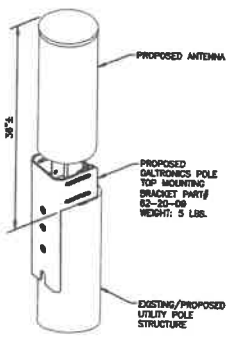

ANTENNA MOUNT DETAIL
SCALE: N.T.S.

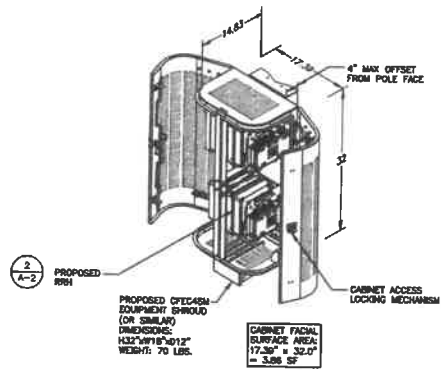

NO BATTERY BACKUP OR AUXILIARY OUTLETS FOR BACKUP POWER ARE BEING PROVIDED IN THIS DESIGN.

NOTE: MOUNT PER MANUFACTURER'S SPECIFICATIONS.

EQUIPMENT CABINET DETAIL
SCALE: N.T.S.

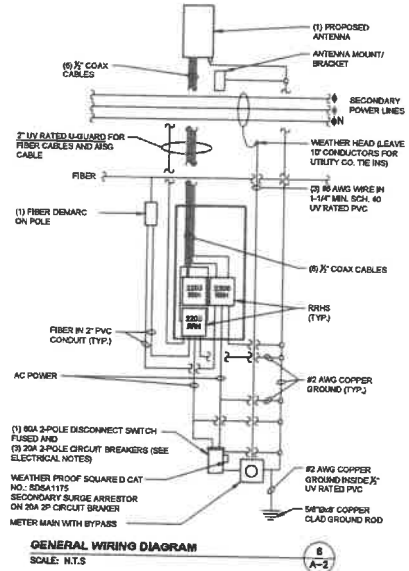

GENERAL WIRING DIAGRAM
SCALE: N.T.S.

ORDER FOR CONDUIT & POLE LOCATION

In the City Council for the City of Salem, Massachusetts.

ORDERED:

That permission be and hereby is granted to Comcast Cable Communications Management LCC., to lay and maintain underground conduits, manholes and poles, with the wires and cables to be placed therein, under and above the surface of the following public way or ways as requested in petition of said Company dated June 7, 2019

Essex Street: Excavating to place (1) 3'x3' manhole over the existing conduit and excavating to place (1) 4" PVC Conduit 13'+/_ to number 127 Essex Street.

Substantially as shown on plan, filed with said petition.

Also that permission be and hereby is granted said Comcast to lay and maintain underground conduits, manholes, cables and wires in the above or intersecting public ways for the purpose of making connections with such poles and buildings as it may desire for distributing purposes.

The foregoing permission is subject to the following conditions:

1. The conduits and manholes shall be of such materials and construction and all work done in such manner as to be satisfactory to the City Council or to such officers as it may appoint to the supervision of the work.
2. Said Company shall indemnify and save the City harmless against all damages, costs and expense whatsoever to which the City may be subjected in consequence of the acts or neglect of said Company, its agents or servants, or in any manner arising from the rights and privileges granted it by the City.
3. In addition said Company shall, before a public way is disturbed for the laying of its wire or conduits, execute its bond in a penal sum of One Hundred Thousand Dollars (\$100,000) (reference being had to the bond already on file with said City) conditioned for the faithful performance of its duties under this permit.
4. Said Company shall comply with the requirements of existing by-laws and such as may hereafter be adopted governing the construction and maintenance of conduits and wires, so far as the same are not inconsistent with the laws of the Commonwealth.

I hereby certify that the foregoing order was adopted at a meeting of the City Council for the City of Salem, Massachusetts, held on the _____ day of _____ 2019.

(over)

City Clerk

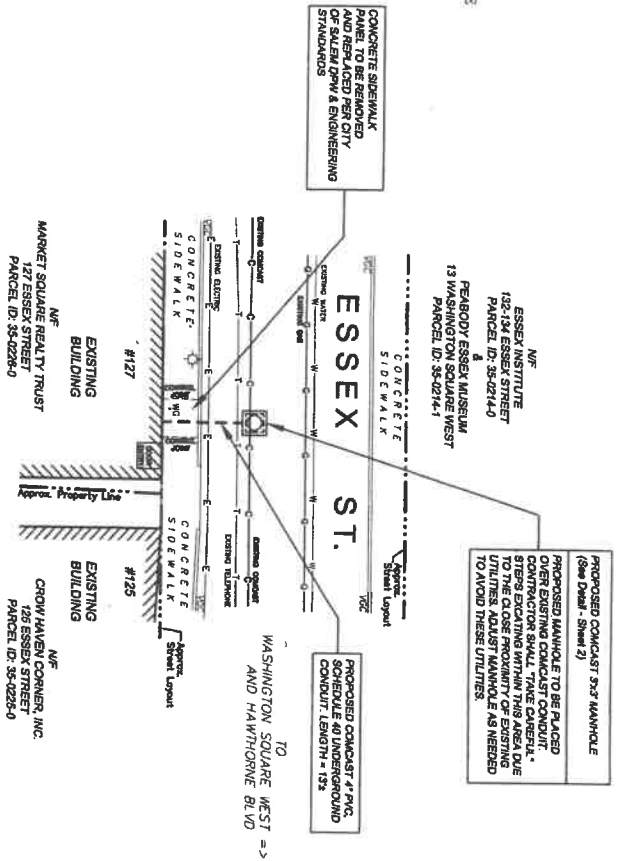

GENERAL LEGEND

- SMH SEWER MANHOLE
- W/G WATER GATE
- DMH DRAIN MANHOLE
- GS GAS GATE
- EMH ELECTRIC MANHOLE
- U/P UTILITY POLE
- CB CATCH BASIN
- VGC VERT. GRANITE CURB
- C COMCAST UNDERGROUND CABLE
- OHW OVERHEAD WIRES
- G GAS LINE
- W WATER LINE
- S SEWER LINE
- E UNDERGROUND ELECTRIC LINE
- T UNDERGROUND TELEPHONE
- PROPOSED COMCAST UNDERGROUND CONDUITS



- NOTES:**
- This plan was prepared from record data on file at the City of Salem, the Essex South Registry of Deeds, and a field location tape survey performed by this office on June 14, 2019.
 - The locations of underground utilities as shown are based on above ground structures and record drawings. If any, provided to the Surveyor. The locations of underground utilities/structures may vary from location hereon and are not warranted to be accurate and/or correct. Additional buried utilities/structures may be encountered. No excavations were performed during the progress of this survey to locate buried utilities/structures.
 - Prior to any construction the Contractor shall notify DIG-SAFE at least 72 hours in advance at 811 (National Call Number) for verification of utilities and for field locations.
 - It is the responsibility of the Utility Contractor installing the Comcast underground conduit to notify those utility companies not associated with the DIG-SAFE system to verify the locations of their respective utilities. Also, the installing contractor shall be responsible for repairing or replacing any traffic signal loops damaged during the installation of the new Comcast underground conduit.
 - All work to be performed is the installation of a Comcast 4" PVC, Sch. 40 underground conduit and a 3x3" manhole to service #127 Essex Street.
 - All work shall conform to the approving authorities Engineering and DPW Standards.
 - Upon completion of the trench work for the day, the contractor shall backfill, compact and pave the trench and the work area shall be broom swept clean. In grassed areas the trench shall be loamed and seeded and hay mulch spread to keep the area stabilized until the grass has taken hold.
 - Street/Property lines are not the result of a boundary survey and are considered to be approximate.

CONSTRUCTION NOTES:

- Following the Dig-Safe "mark out" and field verification of the existing underground utilities, the Proposed 4" PVC, Sch. 40 Comcast Conduit and Proposed 3x3" manhole shall be adjusted in the field by the utility contractor to avoid being located over any existing utilities.

PROPOSED COMCAST UNDERGROUND	
ESSEX COUNTY	
PLAN OF LAND	
IN	
SALEM, MA	
Prepared for:	COMCAST 9 FORBES ROAD, SUITE 108 WOBURN, MA 01801
Prepared By:	DEWSNAP ENGINEERING ASSOC. LLP 173 Lincoln Avenue - Salem, MA 01968 Tel. # (781) 233-0995
Date:	JULY 2, 2019
Checked By:	F.D.D. & P.A.D.
Drawn By:	P.A.D.
Field By:	P.A.D. & A.P.D.
Scale:	As Shown
PROJECT LOCATION:	127 ESSEX STREET WARD 1, PRECINCT 1
Sheet No. 1 of 2	

SHEA CONCRETE PRODUCTS
 MANHOLE 3' X 3' X 2'-6"

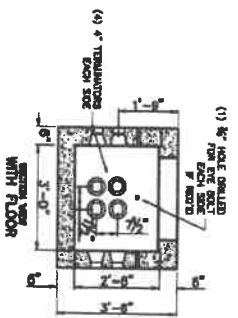
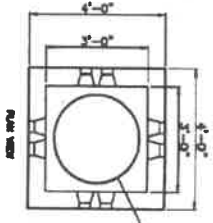

1. CONCRETE SHALL BE CASTED IN PLACE TO THE FINISH SURFACE. ALL REINFORCING SHALL BE PLACED IN THE CONCRETE BEFORE THE CONCRETE IS PLACED. ALL REINFORCING SHALL BE PROTECTED FROM THE WEATHER AND SHALL BE PROTECTED FROM THE GROUND. ALL REINFORCING SHALL BE PROTECTED FROM THE GROUND. ALL REINFORCING SHALL BE PROTECTED FROM THE GROUND.

SHEA CONCRETE - 3' X 3' X 2'-6" MANHOLE

DETAIL NOTES:

1. The details depicted are for general reference only. The final product used shall be the responsibility of the general contractor and shall be of equal or greater material than that depicted and shall conform to the Engineering/DPW Standards for the city/town where the project is located.

EAST JORDAN IRON WORKS - FRAME & COVER DETAIL

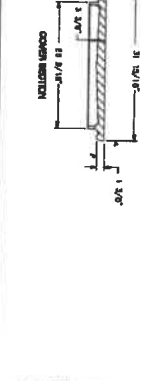
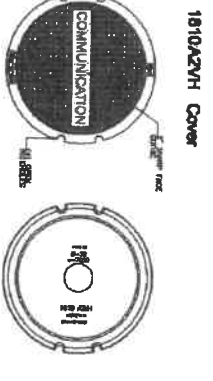
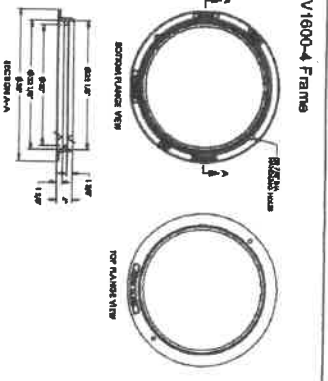

NOT TO SCALE

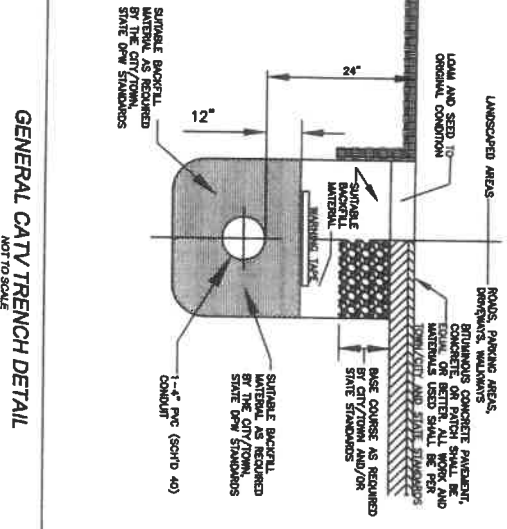

"D E T A I L S"

PROPOSED COMCAST UNDERGROUND ESSEX COUNTY

PLAN OF LAND IN SALEM, MA

Prepared for:	COMCAST 9 FORBES ROAD, SUITE 88 WOBURN, MA 01801	Prepared by:	DEWSNAP ENGINEERING ASSOC. LLP 178 LUXON AVENUE - SALEM, MA 01968 Tel: (781) 233-0595
Date:	JULY 2, 2019	Scale:	As Shown
Checked By:	F.D.D. & P.A.D.	PROJECT LOCATION:	127 ESSEX STREET WARD 1, PRECINCT 1
Drawn By:	P.A.D.		
Field By:	P.A.D. & A.P.D.		

Frederick Dewsnap, Jr.
 REGISTERED PROFESSIONAL ENGINEER
 NO. 30316
 MASSACHUSETTS



CITY OF SALEM, MASSACHUSETTS

Kimberley Driscoll
Mayor

Office of the Mayor

July 18, 2019

Salem City Council
City Hall
93 Washington Street
Salem, MA 01970

Ladies and Gentlemen of the City Council:

I am very pleased to appoint Rehana Yusif of 260 Washington Street #37 of to serve as one of the two adult members of the Salem Youth Commission. Ms. Yusif will complete the remainder of an unexpired three-year term to conclude on June 23, 2022. She will take the seat previously held by Michael Quigley.

Ms. Yusif is currently a Spanish teacher at Salem High School and, previous to that, had been a science teacher in an after-school program and a camp counselor. In all of these positions she has worked directly with children and youth, helping them to grow and to learn. Ms. Yusif earned a Bachelor's degree from Westfield State University and a Master's degree in Teaching Spanish from Salem State University.

We are fortunate Ms. Yusif is willing to step into this role and to serve our community. I strongly recommend confirmation of her appointment to the Youth Commission as one of the two adult members.

Very truly yours,

Kimberley Driscoll
Mayor
City of Salem

Rehana Yusif

260 Washington St. Apt. 37 Salem, MA 01970 • (978) 235-6523 • Rehanayusif@yahoo.com

EDUCATION

Salem State University, Salem, MA
Masters of Arts, Teaching Spanish May 2020
GPA: 3.87/4.00
Westfield State University, Westfield, MA
Bachelor of Science, Criminal Justice May 2017
GPA: 3.457/4.00
Bachelor of Arts, Spanish

ACADEMIC ACHIEVEMENTS

Dean's List – 7/8 Semesters
National Honor Society
Spanish Honor Society
Academic Excellence Award

GLOBAL EXPERIENCE

Pontificia Universidad Católica Madre y Maestra Santiago, DR January – April 2016

- Volunteered in Puerto Plata, Santiago and Santo Domingo
- Built a hospital and informed residents on the environment and their health
- Maintained a GPA of 3.95/4.00

COLLEGIATE LEADERSHIP

Graduate Assistant – Center For Academic Excellence September 2017 – May 2019

- Collect information about tutoring and SI program
- Create various diagrams based on data collection

Class Council Representative – Student Government Association September 2015 – May 2017

- Report information back to constituents
- Vote on important issues regarding finances, new laws and amendments
- Serve as the Chair of The Food Committee

Residential Assistant – Davis Hall, University Hall August 2014 – May 2017

- Help create a cooperative educational/community environment which contributes to the academic and personal growth and success of each resident

Orientation Leader – Admissions Department June 2014

- Assisted the incoming freshman and transfer students through the transition necessary for a successful college experience
- Provided new students and parents with an introduction to the campus and its resources

EMPLOYMENT

Spanish Teacher, Salem High School August 2017 - Present

- Assess and provide support to 120 student throughout the year
- Maintain discipline in the classroom
- Meet with parents and school administrators in a professional capacity

After School Science Teacher, Mad Science of Western New England September – December 2016

- Create a fun and enjoyable learning environment while teaching up to 20 elementary aged children

Camp Counselor, The Summer Camp, Washington, ME June – August 2017

- Helped create a safe environment for at risk children

- Planned, coordinated, and facilitated activities while guiding campers in personal growth and daily living skills

Packer, Industrial Packaging, Leominster, MA

July 2015 – August 2016

- Responsible for placing chips in boxes, piling boxes into the correct order and preparing them for shipment using various equipment
- Responsible for the translating from English to Spanish in order to relate office needs to line workers

SKILLS

Languages: Twi, and Spanish

Computer: Microsoft Word, Excel, PowerPoint



CITY OF SALEM, MASSACHUSETTS

Kimberley Driscoll
Mayor

Office of the Mayor

September 12, 2019

Salem City Council
City Hall
93 Washington Street
Salem, MA 01970

Ladies and Gentlemen of the City Council:

I am very pleased to appoint Alexandra Maranto of 3 Lemon Street Court #2 to serve as a member of the Salem Bicycling Advisory Committee for a three-year term to expire September 12, 2022. Ms. Maranto is appointed to a seat that is currently vacant and had not previously been filled.

Ms. Maranto bicycles regularly to work and around Salem generally. As a psychotherapist, she has worked in consensus-based decision making and mediated conflict resolution. Before moving here to Salem, Ms. Maranto was involved in the Earn-a-Bike program in Worcester and has experience in the operation of a community-based bike program that increased residents' access to bikes and bicycling infrastructure.

I believe Ms. Maranto will be a welcome addition to the work of the Bicycling Advisory Committee. We are fortunate that she is willing to serve our community in this capacity and I strongly recommend confirmation of her appointment.

Very truly yours,

Kimberley Driscoll
Mayor
City of Salem



CITY OF SALEM, MASSACHUSETTS

Kimberley Driscoll
Mayor

Office of the Mayor

September 12, 2019

Salem City Council
City Hall
93 Washington Street
Salem, MA 01970

Ladies and Gentlemen of the City Council:

I am very pleased to appoint John Wathne of 34 Boardman Street to serve as a member of the Salem Bicycling Advisory Committee for a three-year term to expire September 12, 2022. Mr. Wathne is appointed to a seat that is currently vacant and had not previously been filled.

Mr. Wathne is a structural engineer who has, the course of his work, worked on transportation infrastructure projects. He is also an avid amateur bicyclist, covering – by his estimation – around 6 to 12 miles every couple of days. As a small business owner here in Salem and a cyclist, Mr. Wathne is familiar with the challenges and opportunities in our own bicycling infrastructure and where and how that network can be even further improved.

I believe Mr. Wathne will be a welcome addition to the work of the Bicycling Advisory Committee. We are fortunate that he is willing to serve our community in this capacity and I strongly recommend confirmation of his appointment.

Very truly yours,

A handwritten signature in black ink, appearing to read "Kim Driscoll", written in a cursive style.

Kimberley Driscoll
Mayor
City of Salem



CITY OF SALEM, MASSACHUSETTS

Kimberley Driscoll
Mayor

Office of the Mayor

September 12, 2019

Salem City Council
City Hall
93 Washington Street
Salem, MA 01970

Ladies and Gentlemen of the City Council:

I am very pleased to appoint Matt Caruso of 1 Carol Way #301 to serve as a member of the Salem Bicycling Advisory Committee. Mr. Caruso will be completing the remainder of an unexpired three-year term to conclude February 11, 2022. The seat had been previously held by Richard Frank.

Mr. Caruso is a cycling enthusiast whose current daily commute involves taking his folding bike from Vinnin Square to Salem train station and then from North Station to his office in Copley Square. He has been a member of the New York City Transportation Alternative, Boston Cyclists Union, and East Coast Greenway for many years. As a 16-year rider in the Pan Mass Challenge, Mr. Caruso has raised \$82,000 for the charity. Locally he served as a founding board member of the Salem Jazz and Soul Festival, one of the founding organizers of the Salem Arts Festival, and as an acting manager of Salem Main Streets.

I believe Mr. Caruso will be a welcome addition to the work of the Bicycling Advisory Committee. We are fortunate that he is willing to serve our community in this capacity and I strongly recommend confirmation of his appointment.

Very truly yours,

Kimberley Driscoll
Mayor
City of Salem



CITY OF SALEM, MASSACHUSETTS

Kimberley Driscoll
Mayor

Office of the Mayor

September 12, 2019

Honorable Salem City Council
Salem City Hall
Salem, MA 01970

Ladies and Gentlemen of the Council:

I reappoint, subject to City Council confirmation, Ms. Cynthia Nina-Soto, of 6 Laurent Road, to the Scholarship and Education Committee for a term of three years to expire September 12, 2022.

I recommend confirmation of her reappointment to the committee and ask that you join me in thanking Ms. Nina-Soto for her continued dedicated service and commitment to our community.

Sincerely,

Kimberley Driscoll
Mayor
City of Salem



CITY OF SALEM, MASSACHUSETTS

Kimberley Driscoll
Mayor

Office of the Mayor

September 12, 2019

Honorable Salem City Council
Salem City Hall
Salem, MA 01970

Ladies and Gentlemen of the Council:

I reappoint, subject to City Council confirmation, Ms. Gail Kubik, of 14 Cross Street #1B, to the Sustainability, Energy, and Resiliency Committee for a term of three years to expire September 12, 2022.

I recommend confirmation of her reappointment to the committee and ask that you join me in thanking Ms. Kubik for her continued dedicated service and commitment to our community.

Sincerely,

Kimberley Driscoll
Mayor
City of Salem



CITY OF SALEM, MASSACHUSETTS

Kimberley Driscoll
Mayor

September 12, 2019

Honorable Salem City Council
Salem City Hall
Salem, Massachusetts 01970

Ladies and Gentlemen of the City Council:

I reappoint, subject to City Council confirmation, the following employees:

Name	Position	Term	Term Expiration
Stavroula Meimeteas-Orfanos	Assistant Building Inspector	2 years	September 14, 2021
Stephen Cummings	Assistant Building Inspector	2 years	September 14, 2021

I enthusiastically recommend confirmation of both of these reappointments.

Very truly yours,

A handwritten signature in cursive script that reads "Kim Driscoll".

Kimberley Driscoll
Mayor
City of Salem



CITY OF SALEM

In City Council,

Ordered:

September 12, 2019

That the sum of Three Hundred and Fifty-Six Thousand Eight Hundred and Thirty-Nine Dollars and Sixty-Five Cents (\$356,839.65) be approved within the "Retirement Stabilization Fund-Vacation/Sick Leave Buyback" account (83113-5146) to be expended for the FY 2020 contractual buyback(s) listed below in accordance with the recommendation of Her Honor the Mayor.

Name	Department	Amount
John Anderson	Police	34,280.00
Thomas Brennan	Police	44,570.24
Robert Carter	Police	46,354.22
Nancy O'Donnell	Police	43,151.68
Robert Phelan	Police	44,192.72
Conrad Prosniewski	Police	61,572.80
Lawrence Puleo	Police	33,592.00
Timothy Salvo	Police	41,720.40
Julia Rose	Engineering	7,405.59
		356,839.65



CITY OF SALEM, MASSACHUSETTS

Kimberley Driscoll

September 12, 2019

To the City Council
City Hall
Salem, Massachusetts

Ladies and Gentlemen of the Council:

Enclosed herewith is a request for an appropriation of Three Hundred and Fifty-Six Thousand Eight Hundred and Thirty-Nine Dollars and Sixty-five cents (\$356,839.65) from the "Retirement Stabilization Fund-Vacation/Sick Leave Buyback" account (83113-5146) to fund the retirement buyback cost to be expended for the following employees.

NAME	DEPARTMENT	AMOUNT
John Anderson	Police	34,280.00
Thomas Brennan	Police	44,570.24
Robert Carter	Police	46,354.22
Nancy O'Donnell	Police	43,151.68
Robert Phelan	Police	44,192.72
Conrad Prosniewski	Police	61,572.80
Lawrence Puleo	Police	33,592.00
Timothy Salvo	Police	41,720.40
Julia Rose	Engineering	7,405.59
Total:		<u>\$356,839.65</u>

I recommend passage of the accompanying Order.

Very truly yours,

A handwritten signature in cursive script, appearing to read "Kim Driscoll".

Kimberley Driscoll
Mayor



CITY OF SALEM, MASSACHUSETTS

HUMAN RESOURCES
120 WASHINGTON STREET
TEL. (978) 745-9595 EXT. 5630
FAX (978) 745-7298

KIMBERLEY DRISCOLL
MAYOR

LISA B. CAMMARATA
DIRECTOR OF HUMAN RESOURCES

MEMORANDUM

TO: Laurie Giardella, Director of Finance
DATE: August 26, 2019
RE: Retirement Stabilization Fund

Attached you will find a retirement buy back for a former employee of the Salem Police Department.

This former employee is entitled to the following amount of sick leave and vacation buy back.

Conrad Prosniewski

440 vacation hours @ \$53.08 per hour	\$23,355.20
720 sick hours @ \$53.08 per hour	\$38,217.60
Total:	\$61,572.80

In accordance with the July 2008 Policy, I am requesting you verify the availability of the funds from the Retirement Stabilization Fund, prepare the Council Order, and continue the process in order that my staff can input the information in MUNIS and issue payments to this former employee upon Council approval.

Thank you for your cooperation, and if you should have any questions, please do not hesitate to contact me.

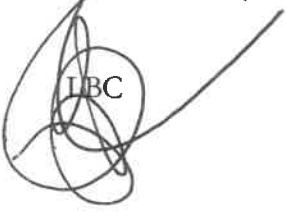
LBC



CITY OF SALEM
APPROVAL-SICK DAYS/VACATION BUY-BACK

From: Department: 210 Police Date: 7/23/2019

Authorized Signature: 
 Department Head/City or Business Manager/School

NAME: Conrad Prosniewski

CALCULATION

					<u>TOTALS</u>
VACATION HOURS	#	<u>440</u>	@	<u>\$53.08</u>	= <u>\$23,355.20</u>
SICK HOURS	#	<u>720</u>	@	<u>\$53.08</u>	= <u>\$38,217.60</u>
PRO-RATED STIPENDS	#		@	<u>\$6,800.00</u>	= <u>\$6,800.00</u>
OTHER HOL x 1.0	#	<u>2</u>	@	<u>430.42</u>	= <u>\$860.84</u>
HOL x 1.5	#	<u>10</u>	@	<u>\$645.64</u>	= <u>\$6,456.40</u>

Total Amount Due: \$75,690.04

Please attach corresponding PAF or other backup to this sheet.

Reason: Captain Prosniewski retired on July 23, 2019. Based on Superior contract, he carried two additional vacation days.

For Human Resources Use Only:

- VACATION HOURS
- SICK HOURS
- PER ACCRUAL REPORT
- OTHER

Org and Object: 83113 - 5144

Recommendation:

Approved

 HR Director/City or Superintendent/Schools



CITY OF SALEM, MASSACHUSETTS

HUMAN RESOURCES
120 WASHINGTON STREET
TEL. (978) 745-9595 EXT. 5630
FAX (978) 745-7298

KIMBERLEY DRISCOLL
MAYOR

LISA B. CAMMARATA
DIRECTOR OF HUMAN RESOURCES

MEMORANDUM

TO: Laurie Giardella, Director of Finance
DATE: August 26, 2019
RE: Retirement Stabilization Fund

Attached you will find a retirement buy back for a former employee of the Salem Police Department.

This former employee is entitled to the following amount of sick leave and vacation buy back.

Robert Carter

368 vacation hours @ \$44.83 per hour	\$16,497.44
666 sick hours @ \$44.83 per hour	\$29,856.78
Total:	\$46,354.22

In accordance with the July 2008 Policy, I am requesting you verify the availability of the funds from the Retirement Stabilization Fund, prepare the Council Order, and continue the process in order that my staff can input the information in MUNIS and issue payments to this former employee upon Council approval.

Thank you for your cooperation, and if you should have any questions, please do not hesitate to contact me.

**CITY OF SALEM
APPROVAL-SICK DAYS/VACATION BUY-BACK**

From: Department: 210 Police Date: 7/9/2019

Authorized Signature: *Mary Sue*
(Department Head/City or Business Manager/School)

NAME: Robert Carter

CALCULATION

					<u>TOTALS</u>
<u>VACATION HOURS</u>	#	<u>368</u>	@	<u>\$44.83</u>	= <u>\$16,497.44</u>
<u>SICK HOURS</u>	#	<u>666</u>	@	<u>\$44.83</u>	= <u>\$29,856.78</u>
<u>PRO-RATED STIPENDS</u>	#		@	<u>\$6,800.00</u>	= <u>\$6,800.00</u>
<u>OTHER</u> HOL x 1.0	#	<u>2</u>	@	<u>364.39</u>	= <u>\$728.78</u>
HOL x 1.5	#	<u>10</u>	@	<u>\$546.59</u>	= <u>\$5,465.90</u>

Total Amount Due: \$59,348.90

Please attach corresponding PAF or other backup to this sheet.

Reason: Sergeant Carter retired on July 8, 2019

For Human Resources Use Only:

- VACATION HOURS
- SICK HOURS
- PER ACCRUAL REPORT
- OTHER

Org and Object: 82113 - 5146

Recommendation:

Approved

[Signature]
 HR Director/City or Superintendent/Schools



CITY OF SALEM, MASSACHUSETTS

HUMAN RESOURCES
120 WASHINGTON STREET
TEL. (978) 745-9595 EXT. 5630
FAX (978) 745-7298

KIMBERLEY DRISCOLL
MAYOR

LISA B. CAMMARATA
DIRECTOR OF HUMAN RESOURCES

MEMORANDUM

TO: Laurie Giardella, Director of Finance
DATE: August 26, 2019
RE: Retirement Stabilization Fund

Attached you will find a retirement buy back for a former employee of the Salem Police Department.

This former employee is entitled to the following amount of sick leave and vacation buy back.

John Anderson

280 vacation hours @ 34.28 per hour	\$9,598.40
720 sick hours @ \$34.28 per hour	\$24,681.60
Total:	\$34,280.00

In accordance with the July 2008 Policy, I am requesting you verify the availability of the funds from the Retirement Stabilization Fund, prepare the Council Order, and continue the process in order that my staff can input the information in MUNIS and issue payments to this former employee upon Council approval.

Thank you for your cooperation, and if you should have any questions, please do not hesitate to contact me.

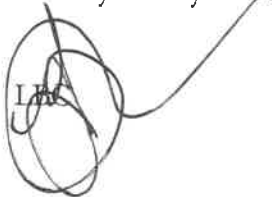
LBC



CITY OF SALEM
APPROVAL-SICK DAYS/VACATION BUY-BACK

From: Department: 210 Police Date: 8/15/2019

Authorized Signature: 
 Department Head/City or Business Manager/School

NAME: John Anderson

CALCULATION

					<u>TOTALS</u>
<u>VACATION HOURS</u>	#	<u>280</u>	@	<u>\$34.28</u>	= <u>\$9,598.40</u>
<u>SICK HOURS</u>	#	<u>720</u>	@	<u>\$34.28</u>	= <u>\$24,681.60</u>
<u>PRO-RATED STIPENDS</u>	#		@	<u>\$6,100.00</u>	= <u>\$6,100.00</u>
<u>OTHER</u> HOL x 1.0	#	<u>2</u>	@	<u>280.04</u>	= <u>\$560.08</u>
HOL x 1.5	#	<u>10</u>	@	<u>\$420.06</u>	= <u>\$4,200.60</u>

Total Amount Due: \$45,140.68

Please attach corresponding PAF or other backup to this sheet.

Reason: Officer John Anderson retired.

For Human Resources Use Only:

- VACATION HOURS
- SICK HOURS
- PER ACCRUAL REPORT
- OTHER

Org and Object: 83113 - 5146

Recommendation:

Approved

 HR Director/City or Superintendent/Schools



CITY OF SALEM, MASSACHUSETTS

HUMAN RESOURCES
120 WASHINGTON STREET
TEL. (978) 745-9595 EXT. 5630
FAX (978) 745-7298

KIMBERLEY DRISCOLL
MAYOR

LISA B. CAMMARATA
DIRECTOR OF HUMAN RESOURCES

MEMORANDUM

TO: Laurie Giardella, Director of Finance
DATE: August 22, 2019
RE: Retirement Stabilization Fund

Attached you will find a retirement buy back for a former employee of the Salem Police Department.

This former employee is entitled to the following amount of sick leave and vacation buy back.

Timothy Salvo

Table with 2 columns: Description and Amount. Rows include 360 vacation hours @ 38.63 per hour (\$13,906.80), 720 sick hours @ \$38.63 per hour (\$27,813.60), and Total (\$41,720.40).

In accordance with the July 2008 Policy, I am requesting you verify the availability of the funds from the Retirement Stabilization Fund, prepare the Council Order, and continue the process in order that my staff can input the information in MUNIS and issue payments to this former employee upon Council approval.

Thank you for your cooperation, and if you should have any questions, please do not hesitate to contact me.

Handwritten initials LBC

Handwritten signature of Laurie Giardella

CITY OF SALEM
APPROVAL-SICK DAYS/VACATION BUY-BACK

From: Department: 210 Police Date: 7/17/2019

Authorized Signature: 
 Department Head/City or Business Manager/School

NAME: Timothy Salvo

CALCULATION

					<u>TOTALS</u>	
<u>VACATION HOURS</u>	#	<u>360</u>	@	<u>\$38.63</u>	= <u>\$13,906.80</u>	
<u>SICK HOURS</u>	#	<u>720</u>	@	<u>\$38.63</u>	= <u>\$27,813.60</u>	
<u>PRO-RATED STIPENDS</u>	#		@	<u>\$6,100.00</u>	= <u>\$6,100.00</u>	
<u>OTHER</u>	HOL x 1.0	#	<u>2</u>	@	<u>314.82</u>	= <u>\$629.64</u>
	HOL x 1.5	#	<u>10</u>	@	<u>\$472.23</u>	= <u>\$4,722.30</u>

Total Amount Due: \$53,172.34

Please attach corresponding PAF or other backup to this sheet.

Reason: Officer Salvo retired on July 17, 2019.

For Human Resources Use Only:

- VACATION HOURS
- SICK HOURS
- PER ACCRUAL REPORT
- OTHER

Org and Object: 83113 - 5146

Recommendation:

Approved

 HR Director/City or Superintendent/Schools



CITY OF SALEM, MASSACHUSETTS

HUMAN RESOURCES
120 WASHINGTON STREET
TEL. (978) 745-9595 EXT. 5630
FAX (978) 745-7298

KIMBERLEY DRISCOLL
MAYOR

LISA B. CAMMARATA
DIRECTOR OF HUMAN RESOURCES

MEMORANDUM

TO: Laurie Giardella, Director of Finance
DATE: August 26, 2019
RE: Retirement Stabilization Fund

Attached you will find a retirement buy back for a former employee of the Salem Police Department.

This former employee is entitled to the following amount of sick leave and vacation buy back.

Lawrence Puleo

400 vacation hours @ \$34.00 per hour	\$13,600.00
588 sick hours @ \$34.00 per hour	\$19,992.00
Total:	\$33,592.00

In accordance with the July 2008 Policy, I am requesting you verify the availability of the funds from the Retirement Stabilization Fund, prepare the Council Order, and continue the process in order that my staff can input the information in MUNIS and issue payments to this former employee upon Council approval.

Thank you for your cooperation, and if you should have any questions, please do not hesitate to contact me.

CITY OF SALEM
APPROVAL-SICK DAYS/VACATION BUY-BACK

From: Department: 210 Police Date: 7/9/2019

Authorized Signature: *Marye Smith*
 Department Head/City or Business Manager/School

NAME: Lawrence Puleo

CALCULATION

					<u>TOTALS</u>
<u>VACATION HOURS</u>	#	<u>400</u>	@	<u>\$34.00</u>	= <u>\$13,600.00</u>
<u>SICK HOURS</u>	#	<u>588</u>	@	<u>\$34.00</u>	= <u>\$19,992.00</u>
<u>PRO-RATED STIPENDS</u>	#		@	<u>\$6,100.00</u>	= <u>\$6,100.00</u>
<u>OTHER</u> HOL x 1.0	#	<u>2</u>	@	<u>277.73</u>	= <u>\$555.46</u>
HOL x 1.5	#	<u>10</u>	@	<u>\$416.60</u>	= <u>\$4,166.00</u>

Total Amount Due: \$44,413.46

Please attach corresponding PAF or other backup to this sheet.

Reason: Officer Puleo retired July 9, 2019.

For Human Resources Use Only:

- VACATION HOURS
- SICK HOURS
- PER ACCRUAL REPORT
- OTHER

Org and Object: 83113 - 5146

Recommendation:

Approved

[Signature]
 HR Director/City or Superintendent/Schools



CITY OF SALEM, MASSACHUSETTS

HUMAN RESOURCES
120 WASHINGTON STREET
TEL. (978) 745-9595 EXT. 5630
FAX (978) 745-7298

KIMBERLEY DRISCOLL
MAYOR

LISA B. CAMMARATA
DIRECTOR OF HUMAN RESOURCES

MEMORANDUM

TO: Laurie Giardella, Director of Finance
DATE: August 22, 2019
RE: Retirement Stabilization Fund

Attached you will find a retirement buy back for a former employee of the Salem Police Department.

This former employee is entitled to the following amount of sick leave and vacation buy back.

Robert Phelan

424 vacation hours @ 38.63 per hour	\$16,379.12
720 sick hours @ \$38.63 per hour	\$27,813.60
Total:	\$44,192.72

In accordance with the July 2008 Policy, I am requesting you verify the availability of the funds from the Retirement Stabilization Fund, prepare the Council Order, and continue the process in order that my staff can input the information in MUNIS and issue payments to this former employee upon Council approval.

Thank you for your cooperation, and if you should have any questions, please do not hesitate to contact me.

CITY OF SALEM
APPROVAL-SICK DAYS/VACATION BUY-BACK

From: Department: 210 Police Date: 7/17/2019

Authorized Signature: 
 Department Head/City or Business Manager/School

NAME: Robert Phelan

CALCULATION

					<u>TOTALS</u>
<u>VACATION HOURS</u>	#	<u>424</u>	@	<u>\$38.63</u>	= <u>\$16,379.12</u>
<u>SICK HOURS</u>	#	<u>720</u>	@	<u>\$38.63</u>	= <u>\$27,813.60</u>
<u>PRO-RATED STIPENDS</u>	#		@	<u>\$6,100.00</u>	= <u>\$6,100.00</u>
<u>OTHER</u>	HOL x 1.0	# <u>2</u>	@	<u>314.82</u>	= <u>\$629.64</u>
	HOL x 1.5	# <u>10</u>	@	<u>\$472.23</u>	= <u>\$4,722.30</u>

Total Amount Due: \$55,644.66

Please attach corresponding PAF or other backup to this sheet.

Reason: Officer Phelan retired on July 17, 2019.

For Human Resources Use Only:

- VACATION HOURS
- SICK HOURS
- PER ACCRUAL REPORT
- OTHER

Org and Object: 83113 - 5146

Recommendation:

Approved

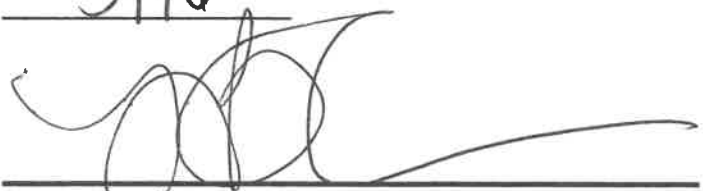
 HR Director/City or Superintendent/Schools



CITY OF SALEM, MASSACHUSETTS

HUMAN RESOURCES
120 WASHINGTON STREET
TEL. (978) 745-9595 EXT. 5630
FAX (978) 745-7298

KIMBERLEY DRISCOLL
MAYOR

LISA B. CAMMARATA
DIRECTOR OF HUMAN RESOURCES

MEMORANDUM

TO: Laurie Giardella, Director of Finance
DATE: August 22, 2019
RE: Retirement Stabilization Fund

Attached you will find a retirement buy back for a former employee of the Salem Police Department.

This former employee is entitled to the following amount of sick leave and vacation buy back.

Nancy O'Donnell

Table with 2 columns: Description and Amount. Rows include 424 vacation hours @ 37.72 per hour (\$15,993.28), 720 sick hours @ \$37.72 per hour (\$27,158.40), and Total: \$43,151.68.

In accordance with the July 2008 Policy, I am requesting you verify the availability of the funds from the Retirement Stabilization Fund, prepare the Council Order, and continue the process in order that my staff can input the information in MUNIS and issue payments to this former employee upon Council approval.

Thank you for your cooperation, and if you should have any questions, please do not hesitate to contact me.

Handwritten signature/initials (LBC)

Handwritten signature (Laurie Giardella)

**CITY OF SALEM
APPROVAL-SICK DAYS/VACATION BUY-BACK**

From: Department: 210 Police Date: 7/18/2019

Authorized Signature: *Nancy O'Donnell*
 Department Head/City or Business Manager/School

NAME: Nancy O'Donnell

CALCULATION

					<u>TOTALS</u>
VACATION HOURS	#	<u>424</u>	@	<u>\$37.72</u>	= <u>\$15,993.28</u>
SICK HOURS	#	<u>720</u>	@	<u>\$37.72</u>	= <u>\$27,158.40</u>
PRO-RATED STIPENDS	#		@	<u>\$6,100.00</u>	= <u>\$6,100.00</u>
OTHER HOL x 1.0	#	<u>2</u>	@	<u>307.49</u>	= <u>\$614.98</u>
HOL x 1.5	#	<u>10</u>	@	<u>\$461.23</u>	= <u>\$4,612.30</u>

Total Amount Due: \$54,478.96

Please attach corresponding PAF or other backup to this sheet.

Reason: Officer O'Donnell retired on July 18, 2019.

For Human Resources Use Only:

- VACATION HOURS
- SICK HOURS
- PER ACCRUAL REPORT
- OTHER

Org and Object: 83113 - 5146

Recommendation: *[Signature]*
 Approved
 HR Director/City or Superintendent/Schools



CITY OF SALEM, MASSACHUSETTS

HUMAN RESOURCES
120 WASHINGTON STREET
TEL. (978) 745-9595 EXT. 5630
FAX (978) 745-7298

KIMBERLEY DRISCOLL
MAYOR

LISA B. CAMMARATA
DIRECTOR OF HUMAN RESOURCES

MEMORANDUM

TO: Laurie Giardella, Director of Finance
DATE: August 22, 2019
RE: Retirement Stabilization Fund

Attached you will find a retirement buy back for a former employee of the Salem Police Department.

This former employee is entitled to the following amount of sick leave and vacation buy back.

Thomas Brennan

424 vacation hours @ 38.96 per hour	\$16,519.04
720 sick hours @ \$38.96 per hour	\$28,051.20
Total:	\$44,570.24

In accordance with the July 2008 Policy, I am requesting you verify the availability of the funds from the Retirement Stabilization Fund, prepare the Council Order, and continue the process in order that my staff can input the information in MUNIS and issue payments to this former employee upon Council approval.

Thank you for your cooperation, and if you should have any questions, please do not hesitate to contact me.

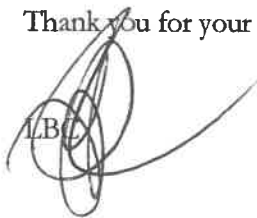
LBC



**CITY OF SALEM
APPROVAL-SICK DAYS/VACATION BUY-BACK**

From: Department: 210 Police **Date:** 7/17/2019

Authorized Signature: 
 Department Head/City or Business Manager/School

NAME: Thomas Brennan

CALCULATION

					<u>TOTALS</u>
VACATION HOURS	#	<u>424</u>	@	<u>\$38.96</u>	= <u>\$16,519.04</u>
SICK HOURS	#	<u>720</u>	@	<u>\$38.96</u>	= <u>\$28,051.20</u>
PRO-RATED STIPENDS	#		@	<u>\$6,100.00</u>	= <u>\$6,100.00</u>
OTHER	HOL x 1.0	#	<u>2</u>	@	<u>317.44</u> = <u>\$634.88</u>
	HOL x 1.5	#	<u>10</u>	@	<u>\$476.16</u> = <u>\$4,761.60</u>

Total Amount Due: \$56,066.72

Please attach corresponding PAF or other backup to this sheet.

Reason: Officer Brennan retired on July 17, 2019.

For Human Resources Use Only:

- VACATION HOURS
- SICK HOURS
- PER ACCRUAL REPORT
- OTHER

Org and Object: 83113 - 5146

Recommendation: 
 Approved
 HR Director/City or Superintendent/Schools



CITY OF SALEM, MASSACHUSETTS

HUMAN RESOURCES
120 WASHINGTON STREET
TEL. (978) 745-9595 EXT. 5630
FAX (978) 745-7298

KIMBERLEY DRISCOLL
MAYOR

LISA B. CAMMARATA
DIRECTOR OF HUMAN RESOURCES

MEMORANDUM

TO: Laurie Giardella, Director of Finance
DATE: August 22, 2019
RE: Retirement Stabilization Fund

Attached you will find a retirement buy back for a former employee of the Water/Engineering Department.

This former employee is entitled to the following amount of vacation buy back.

Julia Rose

159.50 vacation hours @ \$46.43 per hour	\$7,405.59
Total:	\$7,405.59

In accordance with the July 2008 Policy, I am requesting you verify the availability of the funds from the Retirement Stabilization Fund, prepare the Council Order, and continue the process in order that my staff can input the information in MUNIS and issue payments to this former employee upon Council approval.

Thank you for your cooperation, and if you should have any questions, please do not hesitate to contact me.

CITY OF SALEM
APPROVAL-SICK DAYS/VACATION BUY-BACK

From: Department Water/Engineering Dept. Date 8/22/19

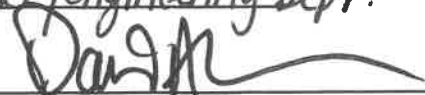
Authorized Signature: 
Department Head/City or Business Manager/School

NAME: Julie Rose

CALCULATION

VACATION HOURS # 159.50 @ \$ 46.43 = \$ 7,405.59

SICK HOURS # _____ @ \$ _____ = \$ _____

PRO-RATED STIPENDS # _____ @ \$ _____ = \$ _____

OTHER # _____ @ \$ _____ = \$ _____

Total Amount Due: \$ 7,405.59
Please attach corresponding PAF or other backup to this sheet.

Reason: Retirement 8/9/19

For Human Resources's Use Only:

- VACATION HOURS
- SICK HOURS
- PER ACCRUAL REPORT
- OTHER

Org and Object: 83113 - 5146

Recommendation:

Approved

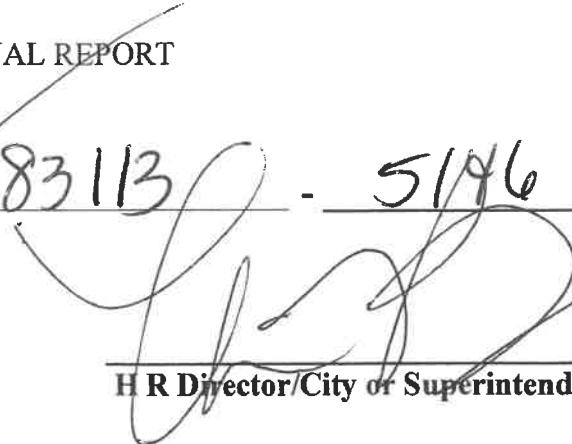

H R Director/City or Superintendent/Schools



CITY OF SALEM

In City Council,

September 12, 2019

Ordered:

That the sum of Three Hundred and Fifty Thousand Dollars (\$350,000.00) is hereby appropriated within the "Capital Outlay Fund 2000" to be expended by the Planning department for Gallows Hill Park Renovation Project in accordance with the recommendation of Her Honor the Mayor.



CITY OF SALEM, MASSACHUSETTS

Kimberley Driscoll
Mayor

Office of the Mayor

September 12, 2019

Salem City Council
City Hall
93 Washington Street
Salem, MA 01970

Ladies and Gentlemen of the City Council:

The enclosed Order appropriates \$350,000 from our short-term capital fund to carry out planned improvements at Gallows Hill Park and to advance the assessment and planning related to remediation of the contaminated soils identified at the Mansell athletic field.

Developed through a multi-year stakeholder engagement process, the project includes expansion of the baseball field to high school size, reconstruction of the Ryan Brennan Memorial Skate Park, trail upgrades, and drainage improvements. Initial project bids came in higher than anticipated. The City secured outside funding through competitive grant programs from private and governmental sources. A portion of the project is being completed pro bono by the Brennan family's construction company and our designer achieved further savings through value engineering and soliciting separate bids directly from skatepark contractors, rather than with a GC's markup. Even with these cost reductions, however, additional funding is necessary to carry out the project.

This request also includes funding to continue to work toward a solution to the contaminated soils at the adjacent Mansell field. These funds will allow the City to continue assessment and planning activities and to conduct necessary coordination with the US EPA and Massachusetts DEP.

I encourage adoption of the enclosed Order and invite you to contact Tom Devine should have any additional questions about this request or the project.

Very truly yours,

Kimberley Driscoll
Mayor
City of Salem

CC: Salem Park and Recreation Commission



CITY OF SALEM, MASSACHUSETTS
DEPARTMENT OF PLANNING AND
COMMUNITY DEVELOPMENT

KIMBERLEY DRISCOLL
MAYOR

TOM DANIEL, AICP
DIRECTOR

98 WASHINGTON STREET, 2ND FLOOR ♦ SALEM, MASSACHUSETTS 01970
978-619-5685

September 6, 2019

Mayor Kimberley Driscoll
Salem City Hall
93 Washington Street
Salem, MA 01970

Mayor Driscoll:

This letter is to request an additional \$350,000 in Short-Term Capital funds to complete the Gallows Hill Park renovation project. Developed through a multi-year stakeholder engagement process, the project includes expansion of the baseball field to high school size, reconstruction of the Ryan Brennan Memorial Skate Park, as well as trail upgrades and drainage improvements.

Initial project bids came in higher than anticipated, resulting in a project cost (lowest bid plus construction contingency) of \$1,685,200 to \$2,145,000, depending on which add-alternatives the City would have selected. Based on feedback from bidders, City staff and the project designer believe that the original bids were inflated partly due to general constructors marking up the cost of subcontracting with their skate park builders. Therefore, the City rebid the skate park and baseball field separately, so that it could get pricing directly from the skate park builders without the general contractor markup. In addition, the project team found additional savings through value engineering and by modifying the project's add-alternatives.

The rebidding resulted in project costs ranging from \$1,345,850 to \$1,401,400, depending on which add-alternatives the City selects. I do not believe we can make further modifications to the project without losing the key components expected by the community. Furthermore, there would be no benefit from bidding the project a third time, since it would further compress the construction schedule, which itself would likely result in higher bids. Therefore, I believe we currently have our best pricing.

In addition to the substantial savings achieved through value engineering and rebidding, project staff have further minimized the project's cost to the City by securing \$471,262 in outside funding through several competitive grant programs, including both private and governmental sources. A portion of the project is being completed pro bono by the Brennan Family's construction company.

This request also includes \$15,000 to continue to work toward a solution to the contaminated soils at the adjacent Mansell soccer field. These funds will allow the City to continue assessment and planning activities and to conduct necessary coordination with the US EPA and Massachusetts DEP.

Please let me know if you would like additional information.

Sincerely,

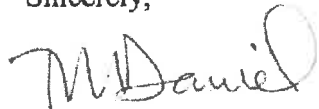
A handwritten signature in cursive script that reads "Tom Daniel". The signature is written in black ink and is positioned to the right of the word "Sincerely,".

Tom Daniel, AICP

CITY OF SALEM
Capital Outlay Expenditure Request Form – FY 2020

From Department: DPCD Date: 9/5/19

Amount: 350,000.00

Description: GALLOWES HILL PARK RENOVATION PROJECT

For Finance Department Use Only:

City Council Approval

CIP Balance: 959,716.69

Recommendation:
 Approved Denied



Finance Director

Processed: Date: _____ By: _____

CO # _____ JE# _____ Trans # _____

Org: _____ Obj: _____

**CITY OF SALEM, MASSACHUSETTS
FY 2020 Short Term Capital Improvement Program Activity - Fund 2000**

Department	Description	Org/Obj	Date To Council	Pending Amount	Date Approved	CO #	Approved Amount	Y-T-D Paid	Amt Not Used	Date Closed	Date Paid	Outstanding Balance
------------	-------------	---------	-----------------	----------------	---------------	------	-----------------	------------	--------------	-------------	-----------	---------------------

FY 2014 - Open Projects												
Police	Bullet Proff Vest Replace	20003-586014	06/30/13		07/18/13	516	38,800.00	38,478.73			6/19/14, 8/31/2015,	321.27

FY 2015 - Open Projects												
School	Bertram Field Light Pole/Array	20003-584615	09/25/14		10/23/14	570	(300,000.00)	239,697.90			6/11/15, 7/16/15,	60,302.10

FY 2017 - Open Projects												
Engineering	Enhanced Bike Crossing	20003-584617	05/26/16		06/09/16	324A	(35,000.00)	29,208.60			5/11/17,	5,791.40
Engineering	Boston St Roadway Design	20003-584617	12/08/16		12/08/16	666	(82,856.00)	82,000.00			8/31/17, 12/28/17,	856.00
Engineering	Essex St Roadway Improv	20003-584617	01/26/17		02/23/17	52	(250,000.00)	242,281.36			6/1/17, 7/27/17,	7,718.64
Recreation	Salem Common Bandstand	20003-584617	05/11/17		05/11/17	284	(25,000.00)	15,420.00			4/19/18, 9/27/18	9,580.00

FY 2018 - Open Projects												
Building Inspector	City Hall Annex Moving Exiens	20003-584618	05/25/17		06/08/17	314	(60,000.00)	55,584.70			5/24/18, 6/7/18,	4,415.30
Fire	General Building Maintenance	20003-584618	05/25/17		06/08/17	314	(25,000.00)	8,612.28			12/7/17	16,387.72
Recreation	Park and Field Improvements	20003-584618	05/25/17		06/08/17	314	(25,000.00)	4,176.33			9/20/18, 11/1,	20,823.67
Planning	Downtown Development Study	20003-584618	05/25/17		06/08/17	314	(50,000.00)					50,000.00
DPS	Lorax Tree Recommendation	20003-584618	05/25/17		06/08/17	314	(75,000.00)	68,469.30			10/19/17, 10/26/17, 1,	6,530.70
Planning	Lafayette Park Renovations	20003-584618	11/16/17		11/16/17	653	(14,850.00)	14,586.66			12/27/18	263.34
Engineering	Willows Parking/Trees/Landscal	20003-586018	01/11/18		01/11/18	10	(25,000.00)	24,051.50			5/31/2018, 1/17/19,	948.50
IT	AV & IT Equip-CLC	20003-586018	01/25/18		01/25/18	58	(72,600.00)	71,511.65			4/12/18, 10/4/18,	1,088.35
Bldg Dept	New Annex-Floor plan changes	20003-584618	02/22/18		03/08/18	147	(80,901.48)	72,194.08			4/12/18, 6/21/18,	8,707.40
Bldg Dept	FF&E - Comm Life Center	20003-586018	03/22/18		04/12/18	204	(214,207.00)	206,161.52			9/13, 9/27, 12/20/18,	8,045.48
Recreation	Willows Pier Repair	20003-586018	06/28/18		06/28/18	440	(64,685.00)	60,060.00			9/13/18	4,625.00

FY 2019 - Open Projects												
Fire	Bay Floor	20001910-5846AA	5/24/2018		06/14/18	339	(75,000.00)	9,900.54			12/2018, 1/17/19,	65,099.46
Library	Carpet Replacement	20001914-5846AB	5/24/2018		06/14/18	339	(68,000.00)	63,229.10			6/20	4,770.90
Rec	Park and Field Improvements	20001917-5846AC	5/24/2018		06/14/18	339	(75,000.00)					75,000.00
Planning	Public Art Underpass	20001920-5846AE	5/24/2018		06/14/18	339	(50,000.00)					50,000.00
Police	Police Equipment	20001921-5846AF	5/24/2018		06/14/18	339	(52,830.00)	23,071.73			9/6/18, 10/4, 10/18,	29,758.27
Parking	Elevator - Addtl funding	20001918-5846AH	11/15/2018		11/15/18	676	(100,000.00)	76,895.00			5/30	23,105.00
Library	HVAC Project	20001914-5846AI	11/15/2018		11/15/18	677	(202,000.00)	47,864.97			6/13/19, 7/18	154,135.03
DPW	DPW Facility Repair	20001923-5846AK	12/6/2018		12/06/18	725	(24,100.00)	1,825.00			3/21/19	22,275.00
Schools	Witchcraft HVAC System	20001925-5846AL	2/14/2019		06/14/18	98	(26,000.00)					26,000.00
Park & Rec	Bertram Field Phase 2 Reno	20001917-5846AN	4/11/2019		04/11/19	230	(33,000.00)					16,738.72
Engineering	Forest River Pool, Bathhouse,	20001929-5846AO	4/11/2019		04/25/19	229	(35,723.00)	16,261.28			6/13, 6/27/19	35,723.00

FY 2020 - Open Projects												
City Clerk	Vault Storage	20002003-5846BA	5/23/2019		06/25/19		(51,125.00)					51,125.00
Fire	SCBA Equipment	20002010-5846BB	5/23/2019		06/25/19		(24,940.00)					24,940.00
Fire	Bldg Main/Upgrades	20002010-5846BC	5/23/2019		06/25/19		(30,000.00)					30,000.00
Park & Rec	Golf Course Equip	20002019-5846BD	5/23/2019		06/25/19		(55,723.00)					55,723.00
Park & Rec	SHS Tennis Courts	20002017	9/12/2019				(200,000.00)					-
Planning	Gallows Hill Pk Renov Pro	20002020-	9/12/2019				(350,000.00)					-

FY 2019 Beginning Balance												
							184,846.30					
							1,121,504.69					
							0.00	0.00	0.00			
							959,716.69	870,798.25				
							409,716.69	1,830,514.94				



CITY OF SALEM

In City Council,

Ordered:

September 12, 2019

That the sum of Two hundred Thousand Dollars (\$200,000.00) is hereby appropriated within the "Capital Outlay Fund 2000" to be expended by the Park & Recreation department for SHS tennis court resurfacing in accordance with the recommendation of Her Honor the Mayor.



CITY OF SALEM, MASSACHUSETTS
Kimberley Driscoll
Mayor

Office of the Mayor

September 12, 2019

Salem City Council
City Hall
93 Washington Street
Salem, MA 01970

Ladies and Gentlemen of the City Council:

The enclosed Order appropriates \$200,000 from our short-term capital fund to carry out upgrades to the tennis courts at Salem High School. These busy courts are utilized, not just by the Salem High School tennis teams, but also by the Department of Park, Recreation, and Community Services and by the public in general.

As you may recall, we had included funding for this project in the FY2020 capital improvement plan, which you approved in June. Now that bids have come in for the work, we are seeking additional funds to close the funding gap and allow this important project to advance.

I encourage adoption of the enclosed Order and invite you to contact either myself or Patricia O'Brien should have any additional questions about this request or the project.

Very truly yours,

A handwritten signature in black ink that reads "Kimberley Driscoll". The signature is written in a cursive style.

Kimberley Driscoll
Mayor
City of Salem

CC: Salem Park and Recreation Commission
Salem School Committee
Ryan Monks, Director of Facilities, Salem Public Schools



CITY OF SALEM, MASSACHUSETTS
PARK, RECREATION & COMMUNITY SERVICE
401 Bridge Street, Salem MA 01970
Tel. (978) 744-0180 / (978) 744-0924
pobrien@salem.com

Kimberley Driscoll
MAYOR

Trish O'Brien
Superintendent

September 5, 2019

The Honorable Kimberley Driscoll
Mayor, City of Salem
93 Washington Street
Salem, MA 01970

Re: Request for short term

Dear Honorable Mayor Driscoll:

The Department of Parks, Recreation and Community services requests
\$ 200,000.00 for the Salem High School Tennis Court re-surfacing.

I currently have \$125,000.00 in CIP #3042303-580750 funds for this project.

Thank you for your consideration on this matter.

Sincerely,

A handwritten signature in black ink, appearing to read "Patricia O'Brien".

Patricia O'Brien
Superintendent, City of Salem
Jean A. Levesque Community Life Center
Park, Recreation and Community Services

CITY OF SALEM
Capital Outlay Expenditure Request Form - FY 2020

From Department: Park & Rec Date: 9-5-19

Amount: 200,000

Description: Additional funds needed
to complete a total renovation
of SALEM H.S. Tennis Courts

For Finance Department Use Only:

City Council Approval

CIP Balance: \$1,959,716.69

Recommendation:
 Approved Denied

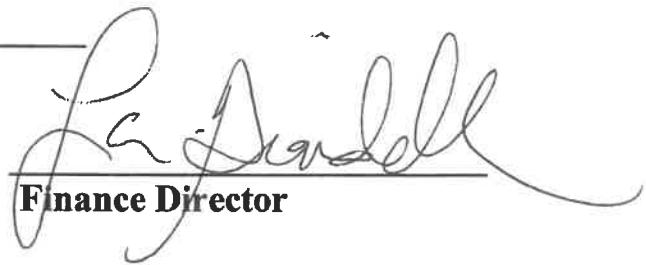
Finance Director

Processed: Date: _____ By: _____

CO # _____ JE# _____ Trans # _____

Org: _____ Obj: _____



CITY OF SALEM

In City Council, September 12, 2019

Ordered: The Salem City Council hereby declares that Lot 1, comprising 21,053+/- S.F. of land shown on a Plan entitled "Plan of Land in Salem, 289 Derby Street, Property of City of Salem; 285 Derby Street, Property of South Harbor Holdings, LLC, Scale 1"=20', March 15, 2018, North Shore Survey Corp., 14 Brown Street, Salem, MA," is hereafter to be known as the Charlotte Forten Park in recognition of her tireless advocacy for the end of slavery, equality for women and people of color, and education for all. As an abolitionist, educator, poet, translator, and women's rights advocate, her life embodied activism and social justice.

Be it further Ordered that a donation fund be established by the City Treasurer to be administered by the City's Public Art Commission to fund the construction and installation at the park of a sculpture, statue or other art piece to honor Charlotte Forten.



CITY OF SALEM, MASSACHUSETTS

Kimberley Driscoll
Mayor

Office of the Mayor

September 12, 2019

Salem City Council
City Hall
93 Washington Street
Salem, MA 01970

Ladies and Gentlemen of the City Council:

In July, Salem residents were invited to vote on their preference for naming the park. The overwhelming choice from that vote was Charlotte Forten Park. I am so proud that Salem will be naming this vibrant new space in honor of a woman who contributed so much to the progress of our community and to our country. I hope that this new public park will be a tribute to Charlotte Forten's legacy and a celebration of all that she achieved for generations to come. I am especially proud that of the two most recent public parks created by the City – Charlotte Forten Park and Remond Park – both are named in honor of women of color who fought for the abolition of slavery and for equal rights for women.

The Order additionally authorizes a donations fund so that the City may accept donations for the purposes of designing and constructing a statue or other memorial of Charlotte Forten for the park. We have already received a number of expressions of interest from individuals and organizations who would like to support such an installation and, working in partnership with the Public Art Commission and the Park and Recreation Commission, I believe we can develop a suitable installation to commemorate Forten and her legacy.

I strongly recommend adoption of the enclosed Order and thank you for your ongoing support for the effort to transform the once vacant dirt lot at 289 Derby Street into the remarkable Charlotte Forten Park.

Very truly yours,

Kimberley Driscoll
Mayor
City of Salem

CC: Salem Park and Recreation Commission



CITY OF SALEM, MASSACHUSETTS

Kimberley Driscoll
Mayor

Office of the Mayor

September 12, 2019

Salem City Council
City Hall
93 Washington Street
Salem, MA 01970

Ladies and Gentlemen of the City Council:

The enclosed resolution recognizes World Duchenne Awareness Day, which took place on September 7th this year. Duchenne muscular dystrophy is a genetic disorder affecting roughly one in every 5,000 male infants born each year.

I invite you to join me to adopting this resolution so our City can add its voice to those speaking up to educate and advocate for greater awareness of this disorder. You can find out more about Duchenne muscular dystrophy and World Duchenne Awareness Day at <https://worldduchenne.org/>.

Very truly yours,

Kimberley Driscoll
Mayor
City of Salem



CITY OF SALEM, MASSACHUSETTS

In City Council, September 12, 2019

Resolved

A RESOLUTION TO RECOGNIZE WORLD DUCHENNE AWARENESS DAY

WHEREAS Duchenne muscular dystrophy (Duchenne) is the most common fatal genetic disorder diagnosed in childhood, affecting approximately one in every 5,000 live male births each year; and

WHEREAS the Duchene gene is found on the X-chromosome, it primarily affects boys; however, it occurs across all races and cultures; and

WHEREAS Duchenne results in progressive loss of strength and is caused by a mutation in the gene that encodes for dystrophin. Because dystrophin is absent, the muscle cells are easily damaged. The progressive muscle weakness leads to serious medical problems, particularly issues relating to the heart and lungs. People with Duchenne typically live into their late twenties; and

WHEREAS Duchenne can be passed from parent to child, but approximately 35% of cases occur because of a random spontaneous mutation. In other words, it can affect anyone. Although there are medical treatments that may help slow its progression, there is currently no cure for Duchenne; and

WHEREAS because it is a rare disease, one of our greatest tools in the fight to end Duchenne is raising awareness; and

WHEREAS: on September 7, 2019 the fifth World Duchenne Awareness Day will take place and Duchenne organizations around the world will raise awareness for all people living with Duchenne muscular dystrophy;

THEREFORE we, the Mayor and City Council of the City of Salem, Massachusetts do hereby recognize September 7, 2019 as World Duchenne Awareness Day and encourage the residents of Salem to increase their awareness and understanding of Duchenne muscular dystrophy.



CITY OF SALEM LEGAL DEPARTMENT

93 WASHINGTON STREET ♦ SALEM, MASSACHUSETTS 01970
TEL: 978-745-9595 ♦ FAX: 978-744-1279

KIMBERLEY DRISCOLL
MAYOR

ELIZABETH RENNARD, ESQ.
CITY SOLICITOR

VICTORIA CALDWELL, ESQ.
ASST. CITY SOLICITOR

September 12, 2019

To the City Council
City Hall
Salem, Massachusetts

Ladies and Gentlemen of the Council

As many of you know, in 1996, the City Council voted by Council Order to accept a large number of streets, but did not take the proper steps to legally accept certain streets shown on the Order. One such street is Robinson Road, a private way owned by numerous abutters including 15 Robinson Road, LLC, 120 Swampscott Road, LLC and R&E Farms, LLC. Michael Weiss is the managing member of the owners of these respective parcels abutting Robinson Road – Parcels 6-0013, 6-0014, 6-0018 and 6-0020.

The acceptance of Robinson Road did not follow the required process for street acceptance as provided in City Ordinance at Chapter 38, Sections 51 through 57 and 91 and Massachusetts General Law Chapter 82. The City Council record indicates that the Council failed to take any of the steps, as shown on the attached Street Acceptance Procedure Summary, when accepting Robinson Road.

Mr. Weiss has requested that this matter be corrected and as such, I respectfully request that this matter be referred to the Committee on Licenses and Legal Affairs so that a public hearing may be scheduled, notice sent to all abutters and ultimately the matter be referred back to the City Council to properly remove Robinson Road from the list of accepted City streets.

Thank you for your consideration.

Sincerely,

Elizabeth Rennard

STREET ACCEPTANCE PROCEDURE SUMMARY

- The city council may with approval of the city solicitor lay out a street. City Ordinance Section 38-51.
- At least seven days prior to the laying out of a street, the city council must provide written notice of its intention to lay out the street. Such notice must be left at the dwelling house of owners of land over which such street is proposed to be laid out. Further, the notice shall specify the time and place appointed by the city council for a meeting for all interested parties who wish to be heard regarding the proposed laying out of the street. City Ordinance Section 38-52.
- The notice in Section 38-52 may not be issued until a detailed plan of the proposed laying out...drawn by a competent engineer has been filed in the office of the city clerk. City Ordinance Section 38-53. Further, such plan shall show the present length, width, lines and grade of the street to be laid out; the abutting lands, with the fences and buildings thereon, and the length of frontage of each estate; the lands to be taken and the names of the owners of such lands; and also showing in red ink the proposed lines and grade of such street. City Ordinance Section 38-91.
- The city council shall hold a hearing for all parties who wish to be heard regarding the proposed laying out. If the city council, in its judgment, deems that the common convenience and benefit of the city inhabitants requires such street to be laid out, it may proceed to lay out such street and shall fix the boundaries and measurement of the street and determine what damages, if any, are sustained by any person in his property by the laying out of such street; shall determine the amount of compensation such person shall receive; shall specify the manner in which such laying out shall be completed; and shall determine the time allowed the owner of the land through which street may pass to take off trees, fences and other property that may obstruct the building of such street. City Ordinance Section 38-55.
- All costs, including the engineer's plan, are paid by the developer or proponent.

City of Salem

In the year two thousand nineteen

An Ordinance to amend an Ordinance relative to a Zoning Map Change

Be it ordained by the City Council of the City of Salem. As follows:

Section I. In accordance with the requirements of Massachusetts General Laws, Chapter 40A, Section 5, that the parcels of real property located at 355 and 373 Highland Avenue and 2, 3, 5, 6 and 10 Cedar Road be rezoned and the City of Salem Zoning Map be amended from Business Highway (B2) and Business Park Development (BPD) districts to the Residential Multi-Family (R3) District.

<u>Address</u>	<u>Assessor's Map and Lot Number</u>
1. 355 Highland Avenue	Map 7, Lot 46
2. 373 Highland Avenue	Map 7, Lot 58
3. 2 Cedar Road	Map 7, Lot 57
4. 3 Cedar Road	Map 7, Lot 47
5. 5 Cedar Road	Map 7, Lot 48
6. 6 Cedar Road	Map 7, Lot 56
7. 10 Cedar Road	Map 7, Lot 55

Section II. This Ordinance shall take effect as provided by City Charter

CORRENTI & DARLING LLP 2019 SEP -9 PM 1:53

ATTORNEYS AT LAW
69 FEDERAL STREET
SALEM, MASSACHUSETTS 01970

CITY CLERK
SALEM, MASS.

JOHN E. DARLING
JOSEPH C. CORRENTI
KRISTIN E. KOLICK

September 9, 2019

TELEPHONE
978-744-0212
FACSIMILE
978-741-4689

VIA HAND DELIVERY

Ilene Simons, City Clerk
City Hall
93 Washington Street
Salem, Massachusetts 01970

Re: K R Starr Realty Holding LLC
355 and 373 Highland Avenue; 2,3,5,6, and 10 Cedar Road
Petition to Amend the Zoning Map

Dear Madam Clerk:

Enclosed for filing please find the following in connection with the above properties:

1. Petition to Salem City Council to Rezone;
2. Owner Authorization letter;
3. Metes and Bounds Description;
4. Descriptive Plot Plan for Zoning Amendment Petition dated September 4, 2019, prepared by Beals + Thomas, Inc.; and
5. Proposed Ordinance.

Pursuant to M.G.L. c. 40A, please notify the City of Salem Planning Board so that the appropriate public hearings, with notice, may be scheduled.

Should you require any further information regarding this Petition, please do not hesitate to contact me.

Sincerely,

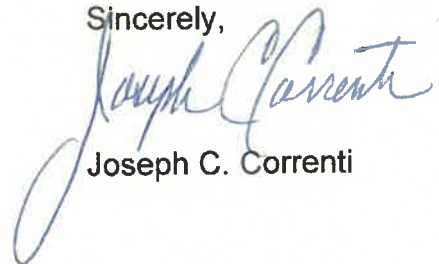

Joseph C. Correnti

JCC:dl
cc: client
K R Starr Realty Holding LLC

PETITION TO SALEM CITY COUNCIL
Under Massachusetts General Laws Chapter 40A
To Rezone Land Shown on Attached Exhibit A

2019 SEP -9 PM 1:53

CITY CLERK
SALEM, MASS.

Councillors:

In accordance with the requirements of Massachusetts General Laws Chapter 40A, Section 5, the Petitioner, K R Starr Realty Holding LLC, is the owner of the real property situated at 355 and 373 Highland Avenue and 2, 3, 5, 6, and 10 Cedar Road (the "Property"), bounded and described and consisting of approximately 4.53 acres, as shown on the plan entitled "Descriptive Plot Plan Plan for Zoning Amendment Petition, Cedar Road Salem, MA (Essex County)" prepared by Beals + Thomas, dated September 4, 2019, attached hereto as Exhibit A. The Petitioner hereby petitions the City Council to amend the City of Salem Zoning Map to rezone the Property from the Business Highway (B2) and Business Park Development (BPD) districts, to the Residential Multi-Family (R3) district.

The Property is surrounded by the R3, B2, and BPD districts. Surrounding uses consist of animal shelter, single family residential, and vacant land. The Property is under agreement with JAG Development Company, LLC, which intends to develop the Property as a mixed-use project, consisting primarily of multifamily residential use. Due to site specific limitations, this project is not feasible under current zoning.

Rezoning to the R3 district will be compatible with the adjacent residential uses and serve as a buffer from the commercial and industrial uses allowed in the BPD.

The requested rezoning to R3 will extend the adjacent R3 district and allow for residential development at the site, which will help to address the ongoing need for housing in the City of Salem and revitalize a vacant site, resulting in tax revenue for the City.

The Petitioner respectfully requests that the City Council act favorably on this Petition.

Respectfully Submitted,

K R STARR REALTY HOLDING LLC,
Owner,
By its Attorney,

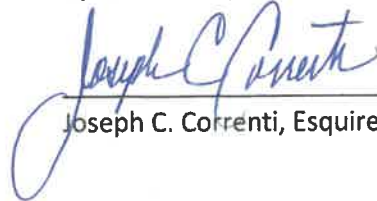

Joseph C. Correnti, Esquire

September 9, 2019

Re: K R Starr Realty Holding LLC
355 and 373 Highland Avenue and
2, 3, 5, 6 and 10 Cedar Road, Salem, Massachusetts

To Whom It May Concern:

Pleased be advised that K R Starr Realty Holding LLC, owner of **355 and 373 Highland Avenue and 2, 3, 5, 6 and 10 Cedar Road, Salem, Massachusetts** (the "Property"), hereby authorizes the law firm of Correnti & Darling LLP ("Developer") to make application to the City of Salem City Council to amend the City of Salem Zoning Map to rezone the Property from the Business Highway (B2) and Business Park Development (BPD) districts to the Residential Multi-Family (R3) district.

Sincerely,

K R Starr Realty Holding LLC

By:

RICK STARR,
MANAGER

Metes and Bounds Description

PROPOSED ZONING CHANGE TO R3 RESIDENTIAL MULTI – FAMILY

Two certain zoning areas in the Commonwealth of Massachusetts, City of Salem, County of Essex situated on the southeasterly side of Highland Avenue and abutting Cedar Road and shown on a plan entitled "DESCRIPTIVE PLOT PLAN FOR ZONING AMENDMENT PETITION, CEDAR ROAD, SALEM, MA..." dated September 4, 2019, prepared by Beals and Thomas, Inc. More particularly bounded and described as follows:

The first area:

Beginning at a point at the northeasterly intersection of Cedar Road and Highland Avenue, thence running;

NORTHEASTERLY	by a curve to the right having a radius a 1486.60 feet and a length of 206.13 feet to a point, said course being by the easterly line of Highland Avenue, thence turning and running;
S 45° 40' 30" E	404.99 feet to a point, said course being by land now or formerly of NE Animal Shelter, thence turning and running;
S 45° 18' 05" W	163.10 feet to a point in the northerly line of Cedar Road, said course being by land now or formerly of Ingemi, thence turning and running;
N 54° 46' 20" W	398.40 feet to the point of beginning at Highland Avenue, said last course being by the northerly line of Cedar Road.

Said first area being Assessor's Parcels 7-46, 7-47 and 7-48.

The second area:

Beginning at a point at the northwesterly intersection of Cedar Road and Highland Avenue, thence running;

S 54° 46' 20" E 393.09 feet to a point; thence turning and running;

S 34° 37' 20" E 110.33 feet to a point, said last two courses being by the southerly line of Cedar Road, thence turning and running;

S 55° 22' 38" W 127.71 feet to a point, thence turning and running;

S 49° 43' 40" E 124.29 feet to a point, thence turning and running;

S 40° 16' 08" W 150.00 feet to a point, said last three courses being by land now or formerly of JL Realty Trust, thence turning and running;

N 49° 43' 40" W 577.57 feet to a point, said last course being in part by land now or formerly Barnes Road Trust and in part by land now or formerly of John M. Ingemi thence turning and running;

N 37° 48' 10" E 267.73 to the point of beginning, said course being by the easterly line of Highland Avenue.

Said second area being Assessor's Parcels 7-55, 7-56, 7-57 and 7-58.

RJB/reh/306502MB001

LEGEND

- LOCAL PROPERTY LINE
- EXISTING ZONE LINE
- PROMISED ZONE LINE
- BUILDING
- DRIVEWAYS CONCRETE PAVEMENT
- ASSESSOR'S BOUNDARY
- ASSESSOR'S CONCRETE ROAD
- LANE COURT LOT

EXISTING ZONING DESIGNATIONS

- BPD** BUSINESS PARK DEVELOPMENT
- R3** BUSINESS HIGHWAY
- R3** RESIDENTIAL MULTI-FAMILY

PROPOSED ZONING DESIGNATIONS

- R3** PROPOSED ZONING CHANGE TO R3
- R3** RESIDENTIAL MULTI-FAMILY

ADJUTERS PROPERTY STREET LISTING

12-14	MC ANAKAL SHELTER HOLDINGS LLC
12-15	K R STARR REALTY HOLDINGS LLC
12-16	K R STARR REALTY HOLDINGS LLC
12-17	JOHN H. INGRAM
12-18	JOHN H. INGRAM
12-19	4 REALTY TRUST
12-20	K R STARR REALTY HOLDINGS LLC
12-21	K R STARR REALTY HOLDINGS LLC
12-22	K R STARR REALTY HOLDINGS LLC
12-23	JOHN H. INGRAM
12-24	BANKS ROAD TRUST
12-25	CITY OF SALKM

OBSERVATIONS

ENCROACHMENT BY N/W JOHN H. INGRAM

NOTES:
1. THIS PLAN IS NOT INTENDED TO BE USED TO CONVEY OWNERSHIP
2. EXISTING BOUNDARIES TAKEN FROM LAND COURT PLAN 7159-B

PREPARED BY:

B.E.A. & T.H.O.M.A.S.
SALINA, MA
(950) 303-1177

DATE: AUGUST 20, 2018

SCALE: 1" = 100'

PROJECT: EX-1

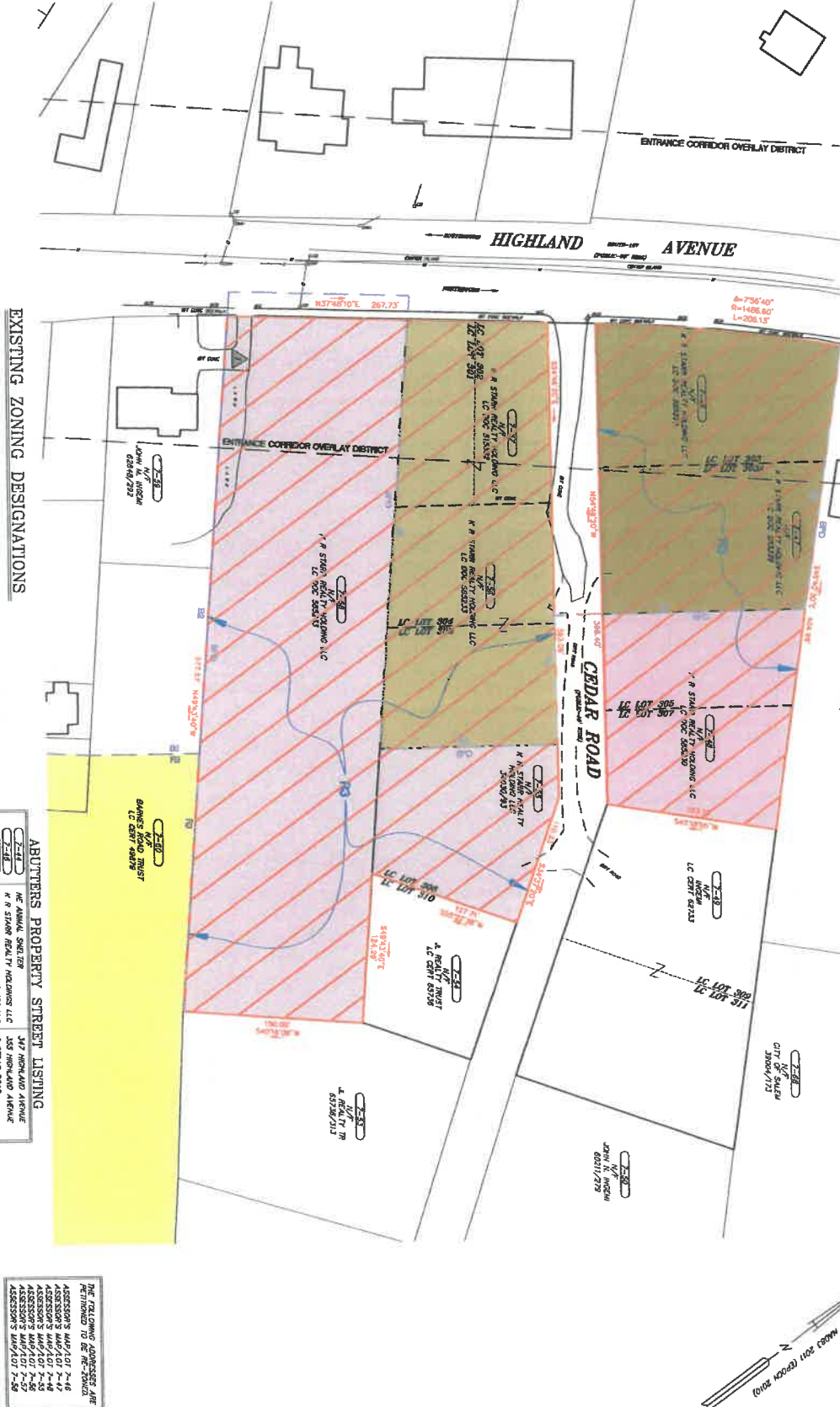

PREPARED FOR:

JEFFERSON APARTMENT GROUP, LLC
2227 WASHINGTON STREET
NEWTON, MA
02459

RECORD OWNER:

K. R. STARR REALTY HOLDINGS LLC

12 LOT 200, 12 CENT, 88888
12 LOT 201, 12 CENT, 88888
12 LOT 202, 12 CENT, 88888
12 LOT 203, 12 CENT, 88888
12 LOT 204, 12 CENT, 88888
12 LOT 205, 12 CENT, 88888

NO.	DESCRIPTION
0	019/01/2018 PROPOSED ZONING CHANGE
1	ISSUE DATE
2	N/A JRA BRH
3	PLD CALC DWN CRKD



SHEET No. 1 OF 1



The
of the **House**
Seven Gables

Education ♦ Preservation ♦ Community Service

July 29, 2019

Salem City Hall
City Clerk's Office
93 Washington Street
Salem, MA 01970

Dear Ilene,

The House of the Seven Gables is hosting our annual fundraiser, **Taste of The Gables**, on Sunday, September 15 from 4:00 – 8:00 pm. Over 20 chefs will be setting up on our oceanfront lawn at 1:00 pm.

We would like to request that the end of Turner St. be closed beginning at 12:00 PM to allow the chefs to unload their trucks. This area would be from The Gables' fence gate adjacent to our lawn to the end of Turner St. Please note: We own the red house on the opposite side at the end of Turner St. We will not block any driveways.

Since the beginning of this event in 2013, the City of Salem has been extremely generous in granting this request and providing a wooden horse that day. We hope that you will be able to give us permission to do this again on Sunday, September 15, 2019.

If you are interested in attending the event, please visit our website for more details. www.7gables.org. **Taste of The Gables** will benefit the preservation of our six historic houses this year, colonial revival gardens, and help us provide educational opportunities to the community including newly arrived immigrant families.

Thank you for your consideration.

Best regards,

Pilar E. Garro

Director of Development



CITY OF SALEM, MASSACHUSETTS

PARK, RECREATION & COMMUNITY SERVICE

401 Bridge Street, Salem MA 01970

Tel. (978) 744-0180/(978) 744-0924

pobrien@salem.com

Kimberley Driscoll
MAYOR

Trish O'Brien
Superintendent

Road Bike/Race/Walk/Parade Application

PLEASE SUBMIT PAYMENT OF \$200 WITH THIS PERMIT APPLICATION TO THE CITY OF SALEM PARK, RECREATION AND COMMUNITY SERVICES DEPARTMENT NO LATER THAN 45 DAYS

PRIOR TO THE EVENT.

Registered Non-Profit Fee \$150

ANY FOR PROFIT EVENTS WILL REQUIRE AN ADDITIONAL 5% FROM THE REGISTRATION FEES POST EVENT.

We, the undersigned, respectfully apply for permission to host a road race/walk in the City of Salem as follows:

Applicant's Name: Brandi Dick

Organization Name: B+S Fitness

Name of Race/Walk/Parade: Wicked Half Marathon

Contact #: 978 204 8588 E-Mail Address: events@bnsfitness.com

Address: 10 Hemeway Rd.

City/State/Zip: Salem MA 01970

Organization Tax Status (please include Tax ID Number): —

What Charities Will This Race/Walk Be Benefiting?
Salem Childrens Charity, Fit Girls MHD, Leap For Education

Approximately How Much of the Race/Walk/Parade Proceeds Will Be Donated to Each Charity(s)
\$2000+

Day of Race/Walk Contact Information:

Name: Ashley Steeves Contact #: 978 594 7050

Date of Event: 9/21/19 Estimated Number of Participants: 800

Time of Event: 7AM Estimated Finish Time of Event: 12PM

Start Location: Willows Soccer Field Finish Location: Willows Soccer Field

Distance of Event: 13.1 miles

Has This Event Been Held Before? Yes No (13th Annual)

Rec'd 8/19

30



City of Salem, Massachusetts Police Department Headquarters

CHIEF OF POLICE
MARY E. BUTLER

09/05/2019

Mrs. Ilene Simons

City of Salem, Ma. Clerk

93 Washington St.

Salem, Ma. 01970

Madam Clerk,

Please be advised that the below listed applicant has applied for a Vehicle for Hire license: **19-105**

Luis Pena-Terrero, 40 Prince St. Apt#2 Salem, Ma, (DOB 01/24/1993) Lic# S18075490

Under guidelines referenced by this office and authorized by the Salem City Council I, representing the Salem Police Dept., respectfully request the Council be notified that this office has **Revoked**

for cause, a Hackney license(Motorized Vehicle for Hire) to the above applicant. Specifically:

City of Salem C.O.R.I. Policy for Vehicle for Hire Operators	___	sec. Sub.
False statements on application	___	
Unfavorable driving history	___	
Other	<u> X </u>	(Police Action)

The above applicant has been informed of said denial/ suspension and that he/she has the right to appeal this decision, in **writing**, to the Council and that this officer may be called upon before the Council to give testimony and/or opinion regarding this decision.

Respectfully Submitted,

Salem Police Traffic Office (978)744-0171

City of Salem

In the year Two Thousand and Nineteen

An Ordinance to amend an ordinance relative to solid waste management.

Be it ordained by the City Council of the City of Salem, as follows:

Section 1.

1) Chapter 36, Section 36-6 Collection fee for certain residences is hereby amended by deleting the fee of "\$18.00" as it appears in paragraph (a) and replacing it with the fee of "\$19.50" and further amending this paragraph (a) by deleting the fee of "\$120.00" and replacing it with a fee of "\$125.00".

2) Chapter 36, Section 36-8 Collection fee for certain commercial establishments is hereby amended by deleting the fee of "\$26.50" and replacing it with the fee of "\$28.50".

Section 2. This Ordinance shall take effect as provided by City Charter.

In City Council June 13, 2019
Referred to the Committee on Ordinances, Licenses and Legal Affairs co-posted with
the Committee of the Whole
In City Council July 18, 2019
Adopted for first passage

ATTEST:

ILENE SIMONS
CITY CLERK

CITY OF SALEM

In the year Two Thousand and Nineteen

An Ordinance to amend an Ordinance relative to Traffic,

Be it Ordained by the City Council of the City of Salem, as follows:

SECTION 1. Amending Chapter 42 Section 10 – “One-way Streets”

By repealing the following:

Beaver Street – from where the easterly end of Silver Street intersects with Beaver Street, thence easterly to the easterly end of the property line of No. 17 Beaver Street.

And retaining the following:

Beaver Street – from where the easterly end of Silver Street intersects with Beaver Street thence easterly to Grove Street. (1/8/78 DPW 5-1498)

SECTION 2. Amending Chapter 42 Section 51 – “Parking Prohibited on Certain Streets”

By repealing the following:

Beaver Street – Parking prohibited on certain streets southerly side.

And replacing it with the following:

Beaver Street – Parking prohibited on certain streets southerly side, from Safford Street extending easterly to a point approximately 70 ft from the intersection with Grove Street.

SECTION 3. This ordinance shall take effect as provided by City Charter

In City Council June 27, 2019

Motion to table until next meeting on July 18, 2019 → Voted

In City Council July 18, 2019

Motion to take from the table – Voted

Adopted for first passage

ATTEST:

ILENE SIMONS
CITY CLERK